

NTuneMON



User's Guide

NTuneMON



User's Guide

Note

Before using this information and the product it supports, be sure to read the general information under “Notices” on page xv.

Seventh Edition (September 1999)

This is a major revision of, and obsoletes, SC31-6266-05. This edition applies to Version 2 Release 6 of NTuneMON (program number 5648-141) and to all subsequent releases and modifications until otherwise indicated in new editions or technical newsletters. See “What Is New in This Book” for a summary of the changes made to this manual. Technical changes or additions to the text are indicated by a vertical line to the left of the change. Make sure you are using the correct edition for the level of the product.

Order publications through your IBM representative or the IBM branch office serving your locality. Publications are not stocked at the address given below.

A form for readers' comments appears at the back of this publication. If the form has been removed, address your comments to:

Department CGF
Design & Information Development
IBM Corporation
PO Box 12195
RESEARCH TRIANGLE PARK NC 27709
USA

When you send information to IBM, you grant IBM a nonexclusive right to use or distribute the information you supply in any way it believes appropriate without incurring any obligation to you.

© Copyright International Business Machines Corporation 1994, 1999. All rights reserved.

US Government Users Restricted Rights – Use, duplication or disclosure restricted by GSA ADP Schedule Contract with IBM Corp.

Contents

Notices	xv
Programming Interface Information	xvi
Notice to Users of Online Versions of This Book	xvi
Trademarks	xvii
About This Book	xix
Who Should Use This Book	xix
How to Use This Book	xix
Terms Used in This Book	xx
How NTune Is Used	xx
How MVS and VM Are Used	xx
How VTAM Is Used	xx
How IBM 3745 Communication Controller Model Numbers Are Used	xx
How CSS and 3746 Model 900 Are Used	xx
How Ethernet-Type LAN Is Used	xx
How Token Ring Is Used	xx
How NCP Version and Release Numbers Are Used	xx
How NTuneMON Version and Release Numbers Are Used	xxi
How Numbers Are Written	xxi
What Is New in This Book	xxi
Displaying or Modifying Transmission Group Timer Values	xxi
Displaying or Modifying GWPACING	xxii
Displaying Use Information about the LXE Control Block	xxii
Changing the Network Definition of a Channel	xxii
Displaying Pre-SNA Resources	xxii
Displaying or Modifying 3746 Model 900 Frame-Relay BAN Connection Balancing Factors	xxii
Displaying or Modifying 3746 Model 900 TIC3 Connection Balancing Factors	xxii
Displaying or Modifying the Minimum Working-Window Value for 3745 Frame Relay	xxiii
Displaying or Modifying the Working-Window Parameters for 3745 Token-Ring	xxiii
Displaying or Modifying the Maximums for Adaptive Pacing Window Sizes	xxiii
Displaying Histograms of Actual CCU and Buffer Usage	xxiii
Displaying and Modifying Virtual Route Alert Timing Information	xxiv
Displaying Other Virtual Route Alert Information	xxiv
Displaying the 3746 Model 900 Hardware Serial Number	xxiv
Accessing the ATUGP Panel with the PL Fast-Path Command	xxiv
Displaying the Status of a Token-Ring Line	xxiv
Displaying Frame-Relay Logical Line Counts	xxiv
Where to Find More Information	xxiv
BookManager Online Books	xxiv
NTuneMON Help	xxv
Chapter 1. Introducing NTuneMON and NTuneNCP Tuning Feature	1-1
NTuneMON	1-3
NTuneNCP	1-15
Chapter 2. Introducing NTuneMON	2-1
Understanding NTuneMON	2-3

Setting Up NTuneMON	2-5
Using NTuneMON Online Help	2-11
Starting NTuneMON	2-12
Solving NTuneMON Problems	2-25
Chapter 3. Using NTuneMON	3-1
Using NTuneMON with PF Keys	3-3
Using NTuneMON with Fast-Path Commands	3-4
Using NetView Commands with NTuneMON	3-6
Working with NTuneMON Panels	3-6
Chapter 4. Using NTuneMON Panels for Monitoring	4-1
About Tuning Fields	4-3
ATUBP NCP Buffer Pool Panel	4-4
ATUBS Buffer Slowdown Information Page 1 Panel	4-10
ATUBX Buffer Slowdown Information Page 2 Panel	4-14
ATUCB Control Block Pools/Tables Panel	4-17
ATUCD CDS NCP Selection Panel	4-27
ATUCH Channel Adapter Details Panel	4-32
ATUCI Channel IP Statistics Panel	4-36
ATUCL 3746-900 Station Details Panel	4-39
ATUCS 3746-900 Logical Lines Panel	4-43
ATUCX Control Block Pools Extension Panel	4-47
ATUDK ISDN Physical Line Details Panel	4-49
ATUDK2 ISDN Physical Line Details Page 2 Panel	4-55
ATUDL ISDN Physical Line Table Panel	4-59
ATUDM ISDN B-Channel Line Table Panel	4-62
ATUDN ISDN B-Channel Line Details Panel	4-65
ATUDP Hexadecimal Storage Display Panel	4-68
ATUDS ISDN Stations Table List Panel	4-71
ATUDT ISDN Station Details Panel	4-73
ATUED PEP Line Details Panel	4-78
ATUEP Ethernet Adapter List Panel	4-81
ATUET Ethernet Adapter Statistics Panel	4-84
ATUFA Frame Relay Subport List Panel	4-88
ATUFB Frame Relay DLCI CIR Parameters Panel	4-92
ATUFC Physical Line List Panel	4-94
ATUFD Frame Relay DLCI to Balance Table Panel	4-99
ATUFI Frame-Relay IP Link Statistics Panel	4-102
ATUFL Frame Relay Multi Station List Panel	4-105
ATUFP Frame Relay Physical Line Details Page 1 Panel	4-108
ATUFP2 Frame Relay Details Page 2 Panel	4-117
ATUFP3 Frame Relay Details Page 3 Panel	4-122
ATUFS1 Frame Relay Switching Equipment Page 1 Panel	4-127
ATUFS2 Frame Relay Switching Equipment Page 2 Panel	4-131
ATUFT1 Frame Relay Terminating Equipment Details Page 1 Panel	4-135
ATUFT2 Frame Relay Terminating Equipment Details Page 2 Panel	4-143
ATUGP Network CB Pools/Tables Panel	4-149
ATUHP HPR & Other Global Flow Control Params Panel	4-153
ATUIA ARP Table Entry Panel	4-155
ATUIB GWNAUs in Use Counts Panel	4-158
ATUIC Non-Dynamic GWNAUs in Use Counts Panel	4-161
ATUID IP Interface Information Detail Panel	4-164
ATUIL IP Interface Information Panel	4-169

ATUIR IP Route Table Entries Panel	4-172
ATUIS IP Router Statistics Page 1 Panel	4-175
ATUIX IP Router Statistics Page 2 Panel	4-180
ATUML Multi-Link Transmission Group Panel	4-184
ATUMT Modify Timer Value Panel	4-189
ATUNA GWNAU Names and HSCBs Panel	4-192
ATUNG HSCBs and GWNAUs Panel	4-195
ATUNI NTuneNCP Information Panel	4-199
ATUNN HSCBs (Networks and HSCB Counts) Panel	4-201
ATUNP NCP Selection Panel	4-204
ATUNT NCP Network Names Table Panel	4-209
ATUNW NCP Wide Selection Panel	4-212
ATUPL SDLC Physical Line Details Panel	4-217
ATUPS Bisync/SS Line Details Panel	4-223
ATUPT Bisync/Start Stop Device List Panel	4-227
ATUSC1 Channel Adapters Panel	4-230
ATUSC2 and ATUSC3 Line Adapters Panels	4-233
ATUSC4 3746 Model 900 Adapters Panel	4-237
ATUSD SDLC Station Details Panel	4-241
ATUSL SDLC Stations List Panel	4-246
ATUSP1 SDLC Peripheral Line Parameters Page 1 Panel	4-249
ATUSP2 SDLC Peripheral Line Parameters Page 2 Panel	4-255
ATUSS Summary Status Panel	4-260
ATUST NCP Function Activation Panel	4-269
ATUTA Token-Ring SNA Station List Panel	4-273
ATUTC Token-Ring Adapter List Panel	4-278
ATUTD NTRI Frame Handlers Logical Line Details Panel	4-285
ATUTF NTRI Frame Handler Logical Lines Panel	4-291
ATUTG Transmission Group Panel	4-294
ATUTI Token-Ring IP Statistics Panel	4-298
ATUTL Token-Ring SNA Station Panel	4-301
ATUTP1 Token-Ring TIC Details Page 1 Panel	4-310
ATUTP2 Token-Ring TIC Details Page 2 Panel	4-319
ATUUH Cycle/Buffer Utilization History Panel	4-325
ATUUT NCP Utilization Panel	4-328
ATUVA Virtual Route Control Block Details Panel	4-331
ATUVR Virtual Route Panel	4-334
ATUVT VR Alert Timer Panel	4-338
ATUXD X.25 Virtual Circuit Details Panel	4-341
ATUXF NPSI Virtual Circuit Statistics Panel	4-346
ATUXH X.25 MCH Physical Line Statistics Panel	4-348
ATUXL X.25 MCH Physical Line List Panel	4-350
ATUXP X.25 MCH Physical Line Details Page 1 Panel	4-353
ATUXP Panel for NPSI	4-353
ATUXP Panel for X.25 ODLC	4-358
ATUXS X.25 MCH Physical Line Details Page 2 Panel	4-362
ATUXV X.25 Virtual Circuit List Panel	4-366
ATUXX X.25 VCCPT Information Panel	4-369
Chapter 5. Using the NTuneNCP Tuning Feature	5-1
Introducing NTuneNCP	5-3
Generating NCP for Tuning with NTuneNCP	5-4
Authorizing NTuneMON Users to NTuneNCP	5-6
Tuning Your Network Using NTuneNCP	5-6

Chapter 6. Using NTuneMON Panels for Tuning	6-1
ATUBP NCP Buffer Pool Panel	6-4
ATUCH Channel Adapter Details Panel	6-10
ATUCL 3746-900 Station Details Panel	6-12
ATUDK ISDN Physical Line Details Panel	6-15
ATUDK2 ISDN Physical Line Details Page 2 Panel	6-19
ATUDT ISDN Station Details Panel	6-24
ATUFB Frame Relay DLCI CIR Parameters Panel	6-26
ATUFD Frame Relay DLCI to Balance Table Panel	6-29
ATUFI Frame-Relay IP Link Statistics Panel	6-32
ATUFP Frame Relay Physical Line Details Page 1 Panel	6-34
ATUFP2 Frame Relay Details Page 2 Panel	6-48
ATUFP3 Frame Relay Details Page 3 Panel	6-53
ATUFS1 Frame Relay Switching Equipment Page 1 Panel	6-61
ATUFT1 Frame Relay Terminating Equipment Details Page 1 Panel	6-64
ATUFT2 Frame Relay Terminating Equipment Details Page 2 Panel	6-78
ATUGP Network CB Pools/Tables Panel	6-81
ATUHP HPR & Other Global Flow Control Parm's Panel	6-84
ATUID IP Interface Information Detail Panel	6-90
ATUML Multi-Link Transmission Group Panel	6-93
ATUMT Modify Timer Value Panel	6-97
ATUPL SDLC Physical Line Details Panel	6-102
ATUSD SDLC Station Details Panel	6-113
ATUSP1 SDLC Peripheral Line Parameters Page 1 Panel	6-122
ATUSP2 SDLC Peripheral Line Parameters Page 2 Panel	6-134
ATUST NCP Function Activation Panel	6-147
ATUTD NTRI Frame Handlers Logical Line Details Panel	6-152
ATUTL Token-Ring SNA Station Panel	6-156
ATUTP1 Token-Ring TIC Details Page 1 Panel	6-170
ATUTP2 Token-Ring TIC Details Page 2 Panel	6-178
ATUVA Virtual Route Control Block Details Panel	6-182
ATUVT VR Alert Timer Panel	6-185
ATUXP X.25 MCH Physical Line Details Page 1 Panel	6-189
Chapter 7. Procedure for Adding SDLC Lines	7-1
Overview of Defining, Enabling, and Updating SDLC Peripheral Lines	7-3
SDLC Line Types	7-3
Defining Spare Lines	7-5
Enabling a Spare SDLC Line	7-5
Defining Redefinable Lines	7-6
Disabling a Redefinable SDLC Line	7-6
Keywords Used for SDLC Peripheral Lines	7-6
Important Restrictions for Spare and Redefinable Lines	7-8
VTAM Support for Spare Lines	7-9
Chapter 8. NTuneMON Alerts	8-1
Chapter 9. NTuneMON Messages	9-1
Information and Error Messages	9-1
Display Messages	9-14
List of Abbreviations	X-1
Glossary	X-5

Bibliography X-21
NCP, SSP, and EP Library X-21
Other Networking Products' Libraries X-22
Related Publications X-23

Index X-25

Figures

1-1.	Locations of NTuneMON and NTuneNCP in the Network	1-3
1-2.	Initial Panel Flow	1-7
1-3.	Pre-SNA Panel Flow	1-8
1-4.	Channel Adapters Panel Flow	1-9
1-5.	Frame-Relay Panel Flow	1-10
1-6.	IP Panel Flow	1-11
1-7.	SDLC Panel Flow	1-12
1-8.	Token-Ring Panel Flow	1-13
1-9.	Virtual Routes Panel Flow	1-14
1-10.	X.25 Panel Flow	1-14
1-11.	ISDN Panel Flow	1-15
2-1.	Location of NTuneMON in the Network	2-3
2-2.	Example of ATUNELST CLIST Data	2-10
2-3.	Example of the Authorized Users' List	2-11
2-4.	NTuneMON Command Options	2-14
3-1.	Sample NTuneMON Panel	3-7
3-2.	Example of Information to be Displayed on the Current Panel	3-8
3-3.	Example of Thresholds for Resource Use	3-9
4-1.	ATUBP NCP Buffer Pool Panel	4-4
4-2.	Example of Boundary Pool Use	4-6
4-3.	ATUBS Buffer Slowdown Information Page 1 Panel	4-10
4-4.	ATUBX Buffer Slowdown Information Page 2 Panel	4-14
4-5.	ATUCB Control Block Pools/Tables Panel Page 1 of 3	4-17
4-6.	ATUCB Control Block Pools/Tables Panel Page 2 of 3	4-17
4-7.	ATUCB Control Block Pools/Tables Panel Page 3 of 3	4-18
4-8.	ATUCD CDS NCP Selection Panel	4-27
4-9.	PF Key Selection Number 1 for the ATUCD CDS NCP Selection Panel	4-28
4-10.	PF Key Selection Number 3 for the ATUCD CDS NCP Selection Panel	4-30
4-11.	PF Key Selection Number 4 for the ATUCD CDS NCP Selection Panel	4-31
4-12.	ATUCH Channel Adapter Details Panel	4-32
4-13.	ATUCI Channel IP Statistics Panel	4-36
4-14.	ATUCL 3746-900 Station Details Panel	4-39
4-15.	ATUCS 3746-900 Logical Lines Panel	4-43
4-16.	ATUCX Control Block Pools Extension Panel	4-47
4-17.	ATUDK ISDN Physical Line Details Panel	4-49
4-18.	ATUDK2 ISDN Physical Line Details Page 2 Panel	4-55
4-19.	ATUDL ISDN Physical Line Table Panel	4-59
4-20.	ATUDM ISDN B-Channel Line Table Panel	4-62
4-21.	ATUDN ISDN B-Channel Line Details Panel	4-65
4-22.	ATUDP Hexadecimal Storage Display Panel	4-68
4-23.	ATUDS ISDN Stations Table List Panel	4-71
4-24.	ATUDT ISDN Station Details Panel	4-73
4-25.	ATUED PEP Line Details Panel	4-78
4-26.	ATUEP Ethernet Adapter List Panel	4-81
4-27.	ATUET Ethernet Adapter Statistics Panel	4-84
4-28.	ATUFA Frame Relay Subport List Panel	4-88
4-29.	ATUFB Frame Relay DLCI CIR Parameters Panel	4-92

4-30.	ATUFC Physical Line List Panel	4-94
4-31.	ATUFD Frame Relay DLCI to Balance Table Panel	4-99
4-32.	ATUFI Frame-Relay IP Link Statistics Panel	4-102
4-33.	ATUFL Frame Relay Multi Station List Panel	4-105
4-34.	ATUFP Frame Relay Physical Line Details Page 1 Panel	4-108
4-35.	ATUFP2 Frame Relay Details Page 2 Panel	4-117
4-36.	ATUFP3 Frame Relay Details Page 3 Panel	4-122
4-37.	ATUFS1 Frame Relay Switching Equipment Page 1 Panel	4-127
4-38.	ATUFS2 Frame Relay Switching Equipment Page 2 Panel	4-131
4-39.	ATUFT1 Frame Relay Terminating Equipment Details Page 1 Panel	4-135
4-40.	ATUFT2 Frame Relay Terminating Equipment Details Page 2 Panel	4-143
4-41.	ATUGP Network CB Pools/Tables Panel	4-149
4-42.	ATUHP HPR & Other Global Flow Control Parm's Panel	4-153
4-43.	ATUIA ARP Table Entry Panel	4-155
4-44.	ATUIB GWNAUs in Use Counts Panel (NCP V6R2 and NCP V6R3)	4-158
4-45.	ATUIB GWNAUs in Use Counts Panel (NCP Releases before NCP V6R2)	4-158
4-46.	ATUIC Non-Dynamic GWNAUs in Use Counts Panel	4-161
4-47.	ATUID IP Interface Information Detail Panel	4-164
4-48.	ATUIL IP Interface Information Panel	4-169
4-49.	ATUIR IP Route Table Entries Panel	4-172
4-50.	ATUIS IP Router Statistics Page 1 Panel	4-175
4-51.	ATUIX IP Router Statistics Page 2 Panel	4-180
4-52.	ATUML Multi-Link Transmission Group Panel	4-184
4-53.	ATUMT Modify Timer Value Panel	4-189
4-54.	ATUNA GWNAU Names and HSCBs Panel	4-192
4-55.	GWNAUs and HSCBs in a Gateway NCP	4-192
4-56.	ATUNG HSCBs and GWNAUs Panel	4-195
4-57.	ATUNI NTuneNCP Information Panel	4-199
4-58.	ATUNN HSCBs (Networks and HSCB Counts) Panel	4-201
4-59.	ATUNP NCP Selection Panel	4-204
4-60.	PF Key Selection Number 2 for the ATUNP NCP Selection Panel	4-206
4-61.	PF Key Selection Number 3 for the ATUNP NCP Selection Panel	4-207
4-62.	PF Key Selection Number 4 for the ATUNP NCP Selection Panel	4-208
4-63.	ATUNT NCP Network Names Table Panel	4-209
4-64.	ATUNW NCP Wide Selection Panel	4-212
4-65.	PF Key Selection Number 2 for the ATUNW NCP Wide Selection Panel	4-215
4-66.	PF Key Selection Number 3 for the ATUNW NCP Wide Selection Panel	4-215
4-67.	PF Key Selection Number 4 for the ATUNW NCP Wide Selection Panel	4-216
4-68.	ATUPL SDLC Physical Line Details Panel	4-217
4-69.	ATUPS Bisync/SS Line Details Panel	4-223
4-70.	ATUPT Bisync/Start Stop Device List Panel	4-227
4-71.	ATUSC1 Channel Adapters Panel	4-230
4-72.	ATUSC2 Line Adapters Page 1 Panel	4-233
4-73.	ATUSC3 Line Adapters Page 2 Panel	4-233
4-74.	ATUSC4 3746 Model 900 Adapters Panel	4-237
4-75.	ATUSD SDLC Station Details Panel	4-241
4-76.	ATUSL SDLC Stations List Panel	4-246
4-77.	ATUSP1 SDLC Peripheral Line Parameters Page 1 Panel	4-249
4-78.	ATUSP2 SDLC Peripheral Line Parameters Page 2 Panel	4-255
4-79.	ATUSS Summary Status Panel	4-260

4-80.	PF Key Selection Number 2 for the ATUSS Summary Status Panel	4-267
4-81.	PF Key Selection Number 3 for the ATUSS Summary Status Panel	4-267
4-82.	ATUST NCP Function Activation Panel	4-269
4-83.	ATUTA Token-Ring SNA Station List Panel	4-273
4-84.	ATUTC Token-Ring Adapter List Panel	4-278
4-85.	ATUTD NTRI Frame Handlers Logical Line Details Panel	4-285
4-86.	ATUTF NTRI Frame Handler Logical Lines Panel	4-291
4-87.	ATUTG Transmission Group Panel	4-294
4-88.	PIUs of Different Priorities in the Outbound Queue	4-295
4-89.	ATUTI Token-Ring IP Statistics Panel	4-298
4-90.	ATUTL Token-Ring SNA Station Panel	4-301
4-91.	ATUTP1 Token-Ring TIC Details Page 1 Panel	4-310
4-92.	PF Key Selection Number 2 for the ATUTP1 Token-Ring TIC Details Page 1 Panel	4-317
4-93.	ATUTP2 Token-Ring TIC Details Page 2 Panel	4-319
4-94.	PF Key Selection Number 2 for the ATUTP2 Token-Ring TIC Details Page 2 Panel	4-323
4-95.	ATUUH Cycle Utilization History Panel	4-325
4-96.	ATUUH Free Buffer History Panel	4-326
4-97.	ATUUT NCP Utilization Panel	4-328
4-98.	Stage Progression for the NCP CCU and Buffer Use Counter	4-329
4-99.	ATUVA Virtual Route Control Block Details Panel	4-331
4-100.	ATUVR Virtual Route Panel	4-334
4-101.	ATUVT VR Alert Timer Panel	4-338
4-102.	ATUXD X.25 Virtual Circuit Details Panel for NPSI	4-341
4-103.	ATUXD X.25 Virtual Circuit Details Panel for X.25 ODLC	4-342
4-104.	ATUXF NPSI Virtual Circuit Statistics Panel	4-346
4-105.	ATUXH X.25 MCH Physical Line Statistics	4-348
4-106.	ATUXL X.25 MCH Physical Line List Panel	4-350
4-107.	ATUXP X.25 MCH Physical Line Details Page 1 Panel for NPSI	4-353
4-108.	ATUXP X.25 MCH Physical Line Details Page 1 Panel for X.25 ODLC	4-358
4-109.	ATUXS X.25 MCH Physical Line Details Page 2 Panel for NPSI	4-362
4-110.	ATUXS X.25 MCH Physical Line Details Page 2 Panel for X.25 ODLC	4-363
4-111.	ATUXV X.25 Virtual Circuit List Panel	4-366
4-112.	ATUXX X.25 VCCPT Information Panel	4-369
5-1.	Location of NTuneNCP and NTuneMON in the Network	5-3
6-1.	ATUBP NCP Buffer Pool Panel	6-4
6-2.	ATUCH Channel Adapter Details Panel	6-10
6-3.	ATUCL 3746-900 Station Details Panel	6-12
6-4.	ATUDK ISDN Physical Line Details Panel	6-15
6-5.	ATUDK2 ISDN Physical Line Details Page 2 Panel	6-19
6-6.	ATUDT ISDN Station Details Panel	6-24
6-7.	ATUFB Frame Relay DLCI CIR Parameters Panel	6-26
6-8.	ATUFD Frame Relay DLCI to Balance Table Panel	6-29
6-9.	ATUFI Frame-Relay IP Link Statistics Panel	6-32
6-10.	ATUFP Frame Relay Physical Line Details Page 1 Panel	6-34
6-11.	ATUFP2 Frame Relay Details Page 2 Panel	6-48
6-12.	ATUFP3 Frame Relay Details Page 3 Panel	6-53
6-13.	ATUFS1 Frame Relay Switching Equipment Page 1 Panel	6-61
6-14.	ATUFT1 Frame Relay Terminating Equipment Details Page 1 Panel	6-64
6-15.	ATUFT2 Frame Relay Terminating Equipment Details Page 2 Panel	6-78
6-16.	ATUGP Network CB Pools/Tables Panel	6-81

6-17.	ATUHP HPR & Other Global Flow Control Params Panel	6-84
6-18.	ATUID IP Interface Information Detail Panel	6-90
6-19.	ATUML Multi-Link Transmission Group Panel	6-93
6-20.	ATUMT Modify Timer Value Panel	6-97
6-21.	ATUPL SDLC Physical Line Details Panel	6-102
6-22.	ATUSD SDLC Station Details Panel	6-113
6-23.	ATUSP1 SDLC Peripheral Line Parameters Page 1 Panel	6-122
6-24.	ATUSP2 SDLC Peripheral Line Parameters Page 2 Panel	6-134
6-25.	ATUST NCP Function Activation Panel	6-147
6-26.	ATUTD NTRI Frame Handlers Logical Line Details Panel	6-152
6-27.	ATUTL Token-Ring SNA Station Panel	6-156
6-28.	ATUTP1 Token-Ring TIC Details Page 1 Panel	6-170
6-29.	PF Key Selection Number 2 for the ATUTP1 Token-Ring TIC Details Page 1 Panel	6-176
6-30.	ATUTP2 Token-Ring TIC Details Page 2 Panel	6-178
6-31.	PF Key Selection Number 2 for the ATUTP2 Token-Ring TIC Details Page 2 Panel	6-180
6-32.	ATUVA Virtual Route Control Block Details Panel	6-182
6-33.	ATUVT VR Alert Timer Panel	6-185
6-34.	ATUXP X.25 MCH Physical Line Details Page 1 Panel for NPSI	6-189
6-35.	ATUXP X.25 MCH Physical Line Details Page 1 Panel for X.25 ODLC	6-190
X-1.	Example of a Language Statement	X-8
X-2.	Example of an NCP Definition Statement	X-8
X-3.	Example of a VTAM Definition Statement	X-8
X-4.	Non-Return-to-Zero Change-on-Ones Recording	X-14

Tables

1-1.	NTuneMON Panel Functions	1-4
1-2.	Initial NTuneMON Panels	1-6
1-3.	Pre-SNA Panel Entry Points	1-7
1-4.	Channel Adapters Panel Entry Points	1-8
1-5.	Frame-Relay Panel Entry Points	1-9
1-6.	IP Panel Entry Points	1-10
1-7.	SDLC Panel Entry Points	1-11
1-8.	Token-Ring Panel Entry Points	1-12
1-9.	Virtual-Route Panel Entry Points	1-13
1-10.	X.25 Panel Entry Points	1-14
1-11.	ISDN Panel Entry Points	1-15
1-12.	Modifiable NCP Functions	1-16
2-1.	NCP Resources Monitored by NTuneMON	2-4
2-2.	Requirements for Analyzing Certain NCP Resources	2-6
2-3.	TYPE Values for Various Line Types	2-16
2-4.	TYPE Option Values	2-22
3-1.	NTuneMON Panels with Fast-Path Commands	3-4
4-1.	SPEED Values for IBM 3746 Model 900 Frame-Relay Lines When CLOCKNG=EXT and VERSION<V7R7	4-110
4-2.	SPEED Values for IBM 3746 Model 900 SDLC Lines When CLOCKNG=EXT and VERSION<V7R7	4-219
4-3.	SPEED Values for IBM 3746 Model 900 SDLC Lines when CLOCKNG=EXT and VERSION<V7R7	4-253
4-4.	SPEED Values for Virtual Circuits When CLOCKNG=EXT and VERSION<V7R7	4-343
4-5.	SPEED Values for IBM 3746 Model 900 Lines When CLOCKNG=EXT and VERSION<V7R7	4-355
4-6.	SPEED Values for X.25 ODLC Lines When CLOCKNG=EXT and VERSION<V7R7	4-359
5-1.	Keywords Used for Tuning	5-7
6-1.	Displayed SPEED Values for TSS and HPTSS Adapters when VERSION<V7R7	6-36
6-2.	Displayed SPEED Values for 3746 Model 900 when CLOCKNG=DIRECT and VERSION<V7R7	6-36
6-3.	Displayed SPEED Values for 3746 Model 900 Frame-Relay Lines When CLOCKNG=EXT and VERSION<V7R7	6-37
6-4.	Segment Sizes Used by NCP	6-85
6-5.	Accumulated Transmission Time by Line Type and Speed	6-86
6-6.	Minimum Link Capacity by Line Type and Speed	6-87
6-7.	Displayed SPEED Values for 3745 SDLC Lines (TSS and HPTSS) when VERSION<V7R7	6-104
6-8.	Displayed SPEED Values for 3746 Model 900 when CLOCKNG=INT or CLOCKNG=DIRECT and VERSION<V7R7	6-104
6-9.	Displayed SPEED Values for 3746 Model 900 SDLC Lines When CLOCKNG=EXT and VERSION<V7R7	6-105
6-10.	Displayed SPEED Values for SDLC Lines (TSS and HPTSS) when VERSION<V7R7	6-130
6-11.	Displayed SPEED Values for 3746 Model 900 SDLC Lines when CLOCKNG=INT or CLOCKNG=DIRECT and VERSION<V7R7	6-130

6-12.	Displayed SPEED Values for 3746 Model 900 SDLC Lines When CLOCKNG=EXT and VERSION<V7R7	6-131
6-13.	Displayed SPEED Values for TSS and HPTSS Adapters when VERSION<V7R7 and VERSION>V5R4	6-191
6-14.	Displayed SPEED Values for 3746 Model 900 when CLOCKNG=INT or CLOCKNG=DIRECT and VERSION<V7R7	6-191
6-15.	Displayed SPEED Values for 3746 Model 900 X.25 Lines When CLOCKNG=EXT and VERSION<V7R7	6-192
8-1.	General NTuneMON Alert	8-3
8-2.	NTuneMON Control Block Pool Alert	8-4
8-3.	Generic Alerts	8-5

Notices

References in this publication to IBM products, programs, or services do not imply that IBM intends to make these available in all countries in which IBM operates. Any reference to an IBM product, program, or service is not intended to state or imply that only IBM's product, program, or service may be used. Any functionally equivalent product, program, or service that does not infringe any of IBM's intellectual property rights may be used instead of the IBM product, program, or service. Evaluation and verification of operation in conjunction with other products, except those expressly designated by IBM, are the user's responsibility.

IBM may have patents or pending patent applications covering subject matter in this document. The furnishing of this document does not give you any license to these patents. You can send license inquiries, in writing, to:

IBM Director of Licensing
IBM Corporation
North Castle Drive
Armonk, NY 10504-1785
U.S.A.

Licensees of this program who wish to have information about it for the purpose of enabling: (i) the exchange of information between independently created programs and other programs (including this one) and (ii) the mutual use of the information which has been exchanged, should contact:

Licensing
IBM Corporation
PO Box 12195
3039 Cornwallis
Research Triangle Park, NC 27709-2195
U.S.A

Such information may be available, subject to appropriate terms and conditions, including in some cases, payment of a fee.

For license inquiries regarding double-byte (DBCS) information, contact the IBM Intellectual Property Department in your country or send inquiries, in writing, to:

IBM World Trade Asia Corporation
Licensing
2-31 Roppongi 3-chome, Minato-ku
Tokyo 106, Japan

The licensed program described in this document and all licensed material available for it are provided by IBM under terms of the IBM Customer Agreement, IBM International Program License Agreement, or any equivalent agreement between us.

The following paragraph does not apply to the United Kingdom or any other country where such provisions are inconsistent with local law:

INTERNATIONAL BUSINESS MACHINES CORPORATION PROVIDES THIS PUBLICATION "AS IS" WITHOUT WARRANTY OF ANY KIND, EITHER EXPRESS OR

IMPLIED, INCLUDING, BUT NOT LIMITED TO, THE IMPLIED WARRANTIES OF NON-INFRINGEMENT, MERCHANTABILITY OR FITNESS FOR A PARTICULAR PURPOSE. Some states do not allow disclaimer of express or implied warranties in certain transactions, therefore, this statement may not apply to you.

This information could include technical inaccuracies or typographical errors. Changes are periodically made to the information herein; these changes will be incorporated in new editions of the publication. IBM may make improvements and/or changes in the product(s) and/or the program(s) described in this publication at any time without notice.

Programming Interface Information

This publication is intended to help you diagnose problems in running the Advanced Communication Function for the Network Control Program (NCP). This publication documents diagnosis, modification, and tuning information provided by NTuneMON and its optional tuning feature NTuneNCP.

Attention: Do not use this diagnosis, modification, or tuning information as a programming interface.

Notice to Users of Online Versions of This Book

For online versions of this book, you are authorized to:

- Copy, modify, and print the documentation contained on the media, for use within your enterprise, provided you reproduce the copyright notice, all warning statements, and other required statements on each copy or partial copy.
- Transfer the original unaltered copy of the documentation when you transfer the related IBM product (which may be either machines you own, or programs, if the program's license terms permit a transfer). You must, at the same time, destroy all other copies of the documentation.

You are responsible for payment of any taxes, including personal property taxes, resulting from this authorization.

THERE ARE NO WARRANTIES, EXPRESS OR IMPLIED, INCLUDING THE WARRANTIES OF MERCHANTABILITY AND FITNESS FOR A PARTICULAR PURPOSE.

Some jurisdictions do not allow the exclusion of implied warranties, so the above exclusion may not apply to you.

Your failure to comply with the terms above terminates this authorization. Upon termination, you must destroy your machine-readable documentation.

Trademarks

The following terms are trademarks of the IBM Corporation in the United States or other countries or both.

ACF/VTAM	NTune
AnyNet	NTuneMON
APPN	NTuneNCP
BookManager	Nways
Common User Access	OS/2
eNetwork	OS/390
ESCON	SecureWay
IBM	SystemView
Library Reader	System/370
LPDA	Virtual Machine/ Enterprise Systems Architecture
MVS/ESA	VM/ESA
NetFinity	VTAM
NetView	

TME10 is a trademark of Tivoli Systems, Inc.

Other company, product, and service names may be trademarks or service marks of others.

About This Book

This book helps you use NTuneMON and its optional tuning feature, NTuneNCP. It explains how to use the products and describes the NTuneMON panels and product messages.

Who Should Use This Book

This book is for system programmers, system operators, and IBM support representatives who are responsible for:

- Diagnosing and debugging NCP problems
- Maintaining and managing NCPs and communication controllers
- Managing networks and generating NCPs.

How to Use This Book

This book provides the following information:

- Chapter 1 provides an overview of the NTuneMON product and its optional tuning feature, NTuneNCP. It also lists, by function, the NTuneMON panels and the NCP keywords that can be modified.
- Chapter 2 introduces NTuneMON and provides information on how to set up, install, and start NTuneMON. It also describes solutions to some NTuneMON problems you might encounter.
- Chapter 3 describes how to use NTuneMON, including information on PF keys, fast-path commands, and conventions used on NTuneMON panels.
- Chapter 4 describes each NTuneMON panel, including every field and PF key.
- Chapter 5 introduces the NTuneNCP tuning feature and describes how to generate your NCP for NTuneNCP and give operators tuning authority. It contains a detailed table that shows each NCP keyword that can be modified, the level of NCP required, the tuning field on the NTuneMON panel, the name of the NTuneMON panel, and where the description of the panel can be found in this publication.
- Chapter 6 describes the tuning fields for NTuneMON panels. The description includes for each field that can be tuned the NDF default, valid tuning values, tuning considerations, and tuning suggestions.
- Chapter 7 describes a procedure for adding SDLC lines.
- Chapter 8 describes NTuneMON alerts.
- Chapter 9 describes NTuneMON information and error messages and NTuneMON display messages.

Terms Used in This Book

Some of the terms used in this book require further explanation. The following sections provide more information on how terms are used.

How NTune Is Used

Sometimes the term *NTune* is used to refer to both NTuneMON and its tuning feature NTuneNCP.

How MVS and VM Are Used

The term *MVS* means MVS/ESA and OS/390. The term *VM* means the VM/ESA system in the CMS environment.

How VTAM Is Used

The term *VTAM* means either VTAM or OS/390 SNA Services, in other words, any of the following:

- VTAM for MVS/ESA, VM/ESA, or VSE/ESA
- The SNA Services feature of eNetwork Communications Server for OS/390
- The SNA Services feature of SecureWay Communications Server for OS/390

How IBM 3745 Communication Controller Model Numbers Are Used

In this book, the term 3745 refers to all *IBM 3745 Communication Controller* models (IBM 3745-130, -150, -160, -170, -17A, -210, -21A, -310, -31A, -410, -41A, -610, and -61A). When particular models are discussed, the appropriate model numbers are specified.

How CSS and 3746 Model 900 Are Used

In this book, the term 3746 Model 900 refers to *connectivity subsystem (CSS)*. The IBM 3746 Model 900 is an expansion frame that extends the connectivity and enhances the performance of the 3745.

How Ethernet-Type LAN Is Used

The term *Ethernet-type LAN* means a local area network that uses either the Ethernet Version 2 or IEEE 802.3 protocol.

How Token Ring Is Used

NCP can connect to an IBM Token-Ring Network using the NCP/Token-Ring interconnection (NTRI) or the 3746 Model 900 Connectivity Subsystem (CSS) attachment. This book uses the term *Token Ring* when referring to either type of connection.

How NCP Version and Release Numbers Are Used

In this book, unless otherwise specified, the terms *NCP V6R2*, *NCP V6R3*, *NCP V7R1*, *NCP V7R2*, *NCP V7R3*, *NCP V7R4*, *NCP V7R5*, *NCP V7R6*, *NCP V7R7*, and *NCP V7R8* refer to these releases with or without the optional NCP Feature for 3746 Model 900 support. To use this NCP feature, you must obtain a license for the 3746 Model 900 feature from IBM, and you must have the 3746 Model 900 installed on your controller.

How NTuneMON Version and Release Numbers Are Used

Although many panels in the manual show earlier release numbers in the version-and-release field, the actual NTuneMON V2R6 panels show “V2R6”.

How Numbers Are Written

This book shows numbers over 9999 in metric style, which means that a space is used instead of a comma to separate groups of three digits. For example, the number ten thousand five hundred fifty-two is written 10 552. However, if the number is a keyword value, for example, SALIMIT=65535, it does not include a blank.

What Is New in This Book

This edition contains information on new monitoring and tuning capabilities provided by NTuneMON V2R6 and the NTuneNCP tuning feature. The most significant changes are:

- Displaying or Modifying Transmission Group Timer Values
- Displaying or Modifying GWPACING
- Displaying Use Information about the LXE Control Block
- Changing the Network Definition of a Channel
- Displaying Pre-SNA Resources
- Displaying or Modifying 3746 Model 900 Frame-Relay BAN Connection Balancing Factors
- Displaying or Modifying 3746 Model 900 TIC3 Connection Balancing Factors
- Displaying or Modifying the Minimum Working-Window Value for 3745 Frame Relay
- Displaying or Modifying the Working-Window Parameters for 3745 Token-Ring
- Displaying or Modifying the Maximums for Adaptive Pacing Window Sizes
- Displaying and Modifying Virtual Route Alert Timing Information
- Displaying Histograms of Actual CCU and Buffer Usage
- Displaying Other Virtual Route Alert Information
- Displaying the 3746 Model 900 Hardware Serial Number
- Accessing the ATUGP Panel with the PL Fast-Path Command
- Displaying the Status of a Token-Ring Line
- Displaying Frame-Relay Logical Line Counts

To review all technical changes in detail, read the material that is flagged by vertical bars (|) in the left margin.

Displaying or Modifying Transmission Group Timer Values

You can now display or modify the value of the TGTIMER keyword on the BUILD or NETWORK statement. See the following sections:

- “ATUVT VR Alert Timer Panel” on page 4-338 (monitoring)
- “ATUVT VR Alert Timer Panel” on page 6-185 (tuning)

Corresponding NCP Enhancement: Enhanced hung-TG detection

Displaying or Modifying GWPACING

You can now display or modify the value of the GWPACING keyword on the BUILD or NETWORK statement. In addition, NTuneMON displays more information about the network. See the following sections:

- “ATUGP Network CB Pools/Tables Panel” on page 4-149 (monitoring)
- “ATUGP Network CB Pools/Tables Panel” on page 6-81 (tuning)

Displaying Use Information about the LXE Control Block

The ATUCB panel now includes use information about the LXE control block. See “ATUCB Control Block Pools/Tables Panel” on page 4-17.

Corresponding NCP Enhancement: Using triple-DES encryption for XRF sessions

Changing the Network Definition of a Channel

You can dynamically change the NETID keyword value for a displayed channel. See the following new panels:

- “ATUCH Channel Adapter Details Panel” on page 4-32 (monitoring)
- “ATUCL 3746-900 Station Details Panel” on page 4-39 (monitoring)
- “ATUCH Channel Adapter Details Panel” on page 6-10 (tuning)
- “ATUCL 3746-900 Station Details Panel” on page 6-12 (tuning)

Displaying Pre-SNA Resources

You can display information about bisync, start-stop, and EP resources defined in an NCP PEP gen. See the following new panels:

- “ATUPS Bisync/SS Line Details Panel” on page 4-223
- “ATUPT Bisync/Start Stop Device List Panel” on page 4-227
- “ATUED PEP Line Details Panel” on page 4-78

Displaying or Modifying 3746 Model 900 Frame-Relay BAN Connection Balancing Factors

The ATUFD panel displays the balancing factors that have been defined for 3746 Model 900 frame-relay BAN connections. See the following sections:

- “ATUFD Frame Relay DLCI to Balance Table Panel” on page 4-99 (monitoring)
- “ATUFD Frame Relay DLCI to Balance Table Panel” on page 6-29 (tuning)

Corresponding NCP Enhancement: 3746 Model 900 frame-relay BAN connection balancing

Displaying or Modifying 3746 Model 900 TIC3 Connection Balancing Factors

The monitoring and tuning of duplicate-TIC connection balancing has been extended to 3746 Model 900 TIC3. See “ATUTP1 Token-Ring TIC Details Page 1 Panel” on page 6-170.

Corresponding NCP Enhancement: 3746 Model 900 TIC3 Connection Balancing

Displaying or Modifying the Minimum Working-Window Value for 3745 Frame Relay

You can display or modify the value specified for the new *mww* suboperand of the DYNWIND keyword on the LINE or PU definition statement. See the following sections:

- “ATUFP Frame Relay Physical Line Details Page 1 Panel” on page 4-108 (monitoring)
- “ATUFT1 Frame Relay Terminating Equipment Details Page 1 Panel” on page 4-135 (monitoring)
- “ATUFT2 Frame Relay Terminating Equipment Details Page 2 Panel” on page 4-143 (monitoring)
- “ATUFP Frame Relay Physical Line Details Page 1 Panel” on page 6-34 (tuning)
- “ATUFT1 Frame Relay Terminating Equipment Details Page 1 Panel” on page 6-64 (tuning)

Corresponding NCP Enhancement: Minimum working-window value for 3745 frame relay

Displaying or Modifying the Working-Window Parameters for 3745 Token-Ring

You can display or modify the values specified on the *dw* and *dwc* suboperands of the DYNWIND keyword for NTRI connections. See the following sections:

- “ATUTL Token-Ring SNA Station Panel” on page 4-301 (monitoring)
- “ATUTP1 Token-Ring TIC Details Page 1 Panel” on page 4-310 (monitoring)
- “ATUTL Token-Ring SNA Station Panel” on page 6-156 (tuning)
- “ATUTP1 Token-Ring TIC Details Page 1 Panel” on page 6-170 (tuning)

Corresponding NCP Enhancement: Enhanced DYNWIND support for 3745 Token Ring

Displaying or Modifying the Maximums for Adaptive Pacing Window Sizes

You can display or modify the values specified on the *maximum_window_subarea* and *maximum_window_rex* suboperands of the ADPLIMIT keyword on the BUILD definition statement. See the following sections:

- “ATUHP HPR & Other Global Flow Control Parm's Panel” on page 4-153 (monitoring)
- “ATUHP HPR & Other Global Flow Control Parm's Panel” on page 6-84 (tuning)

Corresponding NCP Enhancement: Limiting the NCP-calculated adaptive pacing window size

Displaying Histograms of Actual CCU and Buffer Usage

A new panel displays a true representation (as opposed to a composite average) of the NCP cycle utilization history or the NCP buffer utilization history. See “ATUUH Cycle/Buffer Utilization History Panel” on page 4-325.

Displaying and Modifying Virtual Route Alert Timing Information

A new panel enables you to display and tune the values of the TGTIMER and VRTIMERn keywords on the BUILD and NETWORK definition statements. See the following sections:

- “ATUVT VR Alert Timer Panel” on page 4-338 (monitoring)
- “ATUVT VR Alert Timer Panel” on page 6-185 (tuning)

Corresponding NCP Enhancement: Enhanced hung-TG detection

Displaying Other Virtual Route Alert Information

NTuneMON now displays detailed VR alert information. See “ATUVA Virtual Route Control Block Details Panel” on page 4-331.

Displaying the 3746 Model 900 Hardware Serial Number

The 3746 Model 900 hardware summary now includes the serial number of the 3746 Model 900 frame. See “ATUSS Summary Status Panel” on page 4-260.

Accessing the ATUGP Panel with the PL Fast-Path Command

The new PL fast-path command provides quick access to the ATUGP Network CB Pools/Tables panel. See “The PL Fast-Path Command” on page 4-217.

Displaying the Status of a Token-Ring Line

The status of the Token-Ring line has been added to the ATUTA panel. See “ATUTA Token-Ring SNA Station List Panel” on page 4-273.

Displaying Frame-Relay Logical Line Counts

NTuneMON now displays the number of active frame-relay logical lines and the total number of frame-relay logical lines defined. See “ATUFC Physical Line List Panel” on page 4-94.

Where to Find More Information

The NTuneMON library consists of this book and *NTuneNCP Feature Reference*, LY43-0039. For more information on related publications, see “Bibliography” on page X-21.

BookManager Online Books

Online copies of *NTuneMON User's Guide* and *NTuneNCP Feature Reference* are available.

Those publications available as softcopy books have cross-document search and hypertext links for speedy, online information retrieval. These softcopy books are grouped together on an electronic bookshelf as part of the *ACF/NCP*, *ACF/SSP*, *EP*, *NPSI*, and *NTuneMON Softcopy Collection Kit*, LK2T-0414, on compact disc read-only memory (CD-ROM).

You can view and search these softcopy books by using BookManager READ products or by using the IBM Library Reader product included on the CD-ROM. For more information on CD-ROMs and softcopy books, see the *IBM Online Libraries*:

| *Softcopy Collection Kit User's Guide*, the BookManager READ documentation, or
| the BookManager home page at:

| **<http://booksrv2.raleigh.ibm.com>**

| You can also access unlicensed softcopy NCP publications in Acrobat or
| BookManager formats from the NCP home page at:

| **<http://www.networking.ibm.com/ncp>**

NTuneMON Help

NTuneMON provides detailed online help for a variety of topics. For more information, see "Using NTuneMON Online Help" on page 2-11.

Chapter 1. Introducing NTuneMON and NTuneNCP Tuning Feature

NTuneMON	1-3
NTuneMON Panel Summary	1-4
NTuneMON Panel Flowcharts	1-5
Initial NTuneMON Panels	1-6
BSC/SS/PEP Panel Group	1-7
Channel Adapters Panel Group	1-8
Frame-Relay Panel Group	1-9
IP Panel Group	1-10
SDLC Panel Group	1-11
Token-Ring Panel Group	1-12
Virtual Routes Panel Group	1-13
X.25 Panel Group	1-14
ISDN Panel Group	1-15
NTuneNCP	1-15

This chapter provides an overview of the NTuneMON product and its optional tuning feature NTuneNCP. It also lists product panels by major function and specifies keywords that can be altered.

NTuneMON and its tuning feature NTuneNCP provide an effective way for you to manage and tune your NCPs.

NTuneMON enables you to monitor your NCPs while your telecommunications network is running. It runs with NetView in the MVS and VM environments and monitors NCPs that were activated by VTAM on the host where NTuneMON is running.

If you have the NTuneMON tuning feature, NTuneNCP, you can use it with NTuneMON to tune resources. NTuneNCP resides in a communication controller and, with NTuneMON, enables you to interactively tune key internal NCP resources.

Figure 1-1 shows the locations of NTuneMON and NTuneNCP in the network:

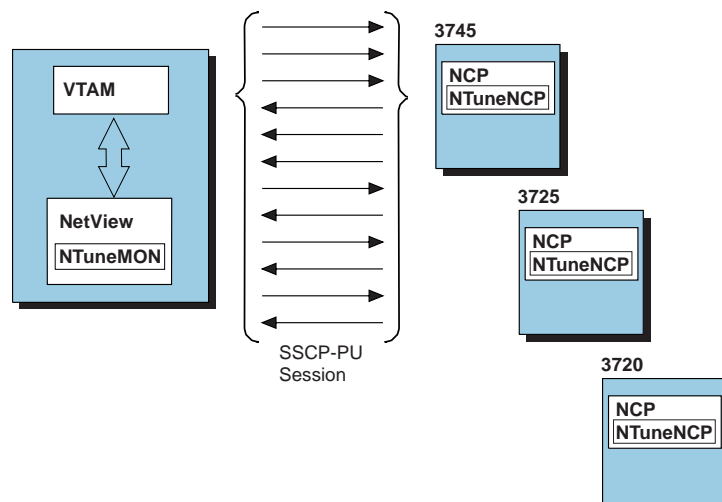

Figure 1-1. Locations of NTuneMON and NTuneNCP in the Network

NTuneMON

NTuneMON is a monitor that provides assistance in detecting, resolving, and preventing problems. NTuneMON provides support for multiple versions of NCP. See “Software Requirements” on page 2-5 for details.

NTuneMON runs on NetView and monitors NCPs that were activated by VTAM on the host where NTuneMON is running. NCPs to be monitored must be in the native network. NTuneMON presents detailed information about NCPs covering a wide variety of areas from frame-relay to control block pools. This information is presented through color panels or through the NetView log. Help panels are also provided.

NTuneMON is also the interface to the NTuneNCP tuning feature, which runs with NCP in the communication controller. Fields on some panels are identified as capable of accepting tuning input. NTuneMON takes that tuning input, validates it

and sends the change requests to NTuneNCP by way of NetView and VTAM. NTuneMON writes all change requests to a NetView log. For more information about NTuneNCP, see "NTuneNCP" on page 1-15.

NTuneMON Panel Summary

Table 1-1 lists the NTuneMON panels by major function.

Table 1-1 (Page 1 of 2). NTuneMON Panel Functions

Function	NTuneMON Panel	Page(s)
General Information	ATUNP NCP Selection	4-204
	ATUCD CDS NCP Selection	4-27
	ATUNW NCP Wide Selection	4-212
	ATUSS Summary Status	4-260
Utilization	ATUUT NCP Utilization	4-328
	ATUUH Cycle/Buffer Utilization History	4-325
Token Ring	ATUTC Token-Ring Adapter List	4-278
	ATUTP1 Token-Ring TIC Details Page 1	4-310, 6-170
	ATUTP2 Token-Ring TIC Details Page 2	4-319, 6-178
	ATUTF NTRI Frame Handler Logical Lines	4-291
	ATUTD NTRI Frame Handlers Logical Line Details	4-285, 6-152
	ATUTA Token-Ring SNA Station List	4-273
	ATUTL Token-Ring SNA Station	4-301, 6-156
Frame Relay	ATUTI Token-Ring IP Statistics	4-298
	ATUFA Frame Relay Support List	4-88
	ATUFB Frame Relay DLCI CIR Parameters	4-92, 6-26
	ATUFC Physical Line List	4-94
	ATUFI Frame-Relay IP Link Statistics	4-102, 6-32
	ATUFL Frame Relay Multi Station List	4-105
	ATUFP Frame Relay Physical Line Details Page 1	4-108, 6-34
	ATUFP2 Frame Relay Details Page 2	4-117, 6-48
	ATUFP3 Frame Relay Details Page 3	4-122, 6-53
	ATUFS1 Frame Relay Switching Equipment Page 1	4-127, 6-61
	ATUFS2 Frame Relay Switching Equipment Page 2	4-131
	ATUFT1 Frame Relay Terminating Equipment Details Page 1	4-135, 6-64
	ATUFT2 Frame Relay Terminating Equipment Details Page 2	4-143, 6-78
IP	ATUFI Frame-Relay IP Link Statistics	4-102, 6-32
	ATUIS IP Router Statistics Page 1	4-175
	ATUIX IP Router Statistics Page 2	4-180
	ATUIL IP Interface Information	4-169
	ATUID IP Interface Information Detail	4-164, 6-90
	ATUIR IP Route Table Entries	4-172
Ethernet	ATUIA ARP Table Entry	4-155
	ATUEP Ethernet Adapter List	4-81
SDLC	ATUET Ethernet Adapter Statistics	4-84
	ATUFC Physical Line List	4-94
	ATUPL SDLC Physical Line Details	4-217, 6-102
	ATUSL SDLC Stations List	4-246
	ATUSD SDLC Station Details	4-241, 6-113
	ATUSP1 SDLC Peripheral Line Parameters Page 1	4-249, 6-122
	ATUSP2 SDLC Peripheral Line Parameters Page 2	4-255, 6-134
	ATUMT Modify Timer Value	4-189, 6-97
Pre-SNA	ATUPS Bisync/SS Line Details	4-223
	ATUPT Bisync/Start Stop Device List	4-227
	ATUED PEP Line Details	4-78
Transmission Groups	ATUTG Transmission Group	4-294
	ATUML Multi-Link Transmission Group	4-184, 6-93
	ATUVT VR Alert Timer	4-338, 6-185

Table 1-1 (Page 2 of 2). NTuneMON Panel Functions

Function	NTuneMON Panel	Page(s)
Gateway Resources	ATUNN HSCBs (Networks and HSCB Counts)	4-201
	ATUNA GWNAU Names and HSCBs	4-192
	ATUNG HSCBs and GWNAUs	4-195
	ATUIB GWNAUs in Use Counts	4-158
	ATUIC Non-Dynamic GWNAUs in Use Counts	4-161
Virtual Routes	ATUVR Virtual Route	4-334
	ATUVT VR Alert Timer	4-338
	ATUVA Virtual Route Control Block Details	4-331, 6-182
High Performance Routing	ATUHP HPR & Other Global Flow Control Parms	4-153, 6-84
Pools	ATUBP NCP Buffer Pool	4-4, 6-4
	ATUBS Buffer Slowdown Information Page 1	4-10
	ATUBX Buffer Slowdown Information Page 2	4-14
	ATUGP Network CB Pools/Tables	4-149, 6-81
	ATUCB Control Block Pools/Tables	4-17
	ATUCX Control Block Pools Extension	4-47
Channel/Line Adapters	ATUSC1 Channel Adapters	4-230
	ATUSC2 Line Adapters Page 1	4-233
	ATUSC3 Line Adapters Page 2	4-233
	ATUSC4 3746 Model 900 Adapters	4-237
	ATUCH Channel Adapter Details	4-32
	ATUCI Channel IP Statistics	4-36
Model 900 ESCON Resources	ATUCS 3746-900 Logical Lines	4-43
	ATUCL 3746-900 Station Details	4-39
X.25 Resources	ATUXL X.25 MCH Physical Line List	4-350
	ATUXP X.25 MCH Physical Line Details Page 1	4-353
	ATUXS X.25 MCH Physical Line Details Page 2	4-362
	ATUXH X.25 MCH Physical Line Statistics	4-348
	ATUXV X.25 Virtual Circuit List	4-366
	ATUXD X.25 Virtual Circuit Details	4-341
	ATUXF NPSI Virtual Circuit Statistics	4-346
	ATUXX X.25 VCCPT Information.	4-369
ISDN Resources	ATUDL ISDN Physical Line Table	4-59
	ATUDK ISDN Physical Line Details	4-49, 6-15
	ATUDK2 ISDN Physical Line Details Page 2	4-55, 6-19
	ATUDM ISDN B-Channel Line Table	4-62
	ATUDN ISDN B-Channel Line Details	4-65
	ATUDS ISDN Stations Table List	4-71
	ATUDT ISDN Station Details	4-73, 6-24
Miscellaneous	ATUNT NCP Network Names Table	4-209
	ATUST NCP Function Activation	4-269, 6-147
	ATUDP Hexadecimal Storage Display	4-68
	ATUNI NTuneNCP Information	4-199

NTuneMON Panel Flowcharts

This section shows the linkage between panels within the larger NTuneMON panel groups:

- “Initial NTuneMON Panels” on page 1-6
- “BSC/SS/PEP Panel Group” on page 1-7
- “Channel Adapters Panel Group” on page 1-8
- “Frame-Relay Panel Group” on page 1-9
- “IP Panel Group” on page 1-10
- “ISDN Panel Group” on page 1-15
- “Token-Ring Panel Group” on page 1-12
- “SDLC Panel Group” on page 1-11

- “Virtual Routes Panel Group” on page 1-13
- “X.25 Panel Group” on page 1-14

Initial NTuneMON Panels

ATUNP, the first panel shown when you start NTuneMON, provides access to the entire NTuneMON system of panels as shown in Figure 1-2 on page 1-7.

Table 1-2. Initial NTuneMON Panels

Entry Point	Fast-Path Commands	External Panels with PF-Key Linkages
ATUNP	NP GEN	All (via F3)
ATUCD	CD	ATUNP
	CDS	ATUNW
ATUNW	NW	ATUNP
		ATUCD
ATUSS	SS	ATUNP
	SUM	ATUCD
	SUMMARY	ATUNW

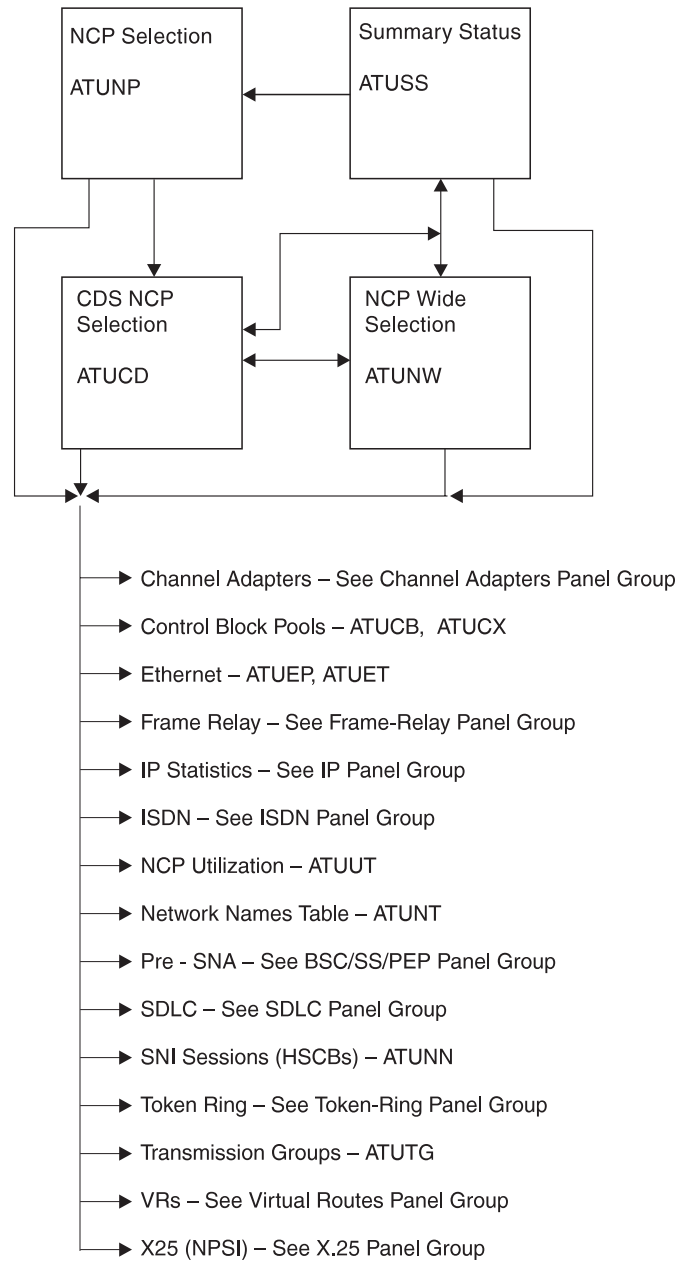

Figure 1-2. Initial Panel Flow

BSC/SS/PEP Panel Group

The BSC/SS/PEP panel group can be entered through panel ATUFC.

Table 1-3. Pre-SNA Panel Entry Points

Entry Point	Fast-Path Commands	External Panels with PF-Key Linkages
ATUFC	BISYNC BSC	ATUNP ATUNW ATUCD

For more details about how to get to panel ATUFC, see “ATUFC Physical Line List Panel” on page 4-94.

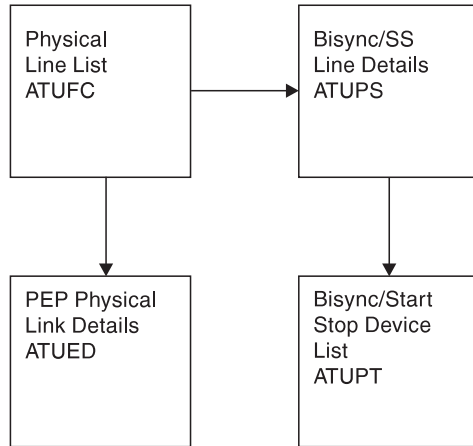

Figure 1-3. Pre-SNA Panel Flow

Channel Adapters Panel Group

The channel-adapters panel group can be entered through panel ATUSC1.

Table 1-4. Channel Adapters Panel Entry Points

Entry Point	Fast-Path Commands	External Panels with PF-Key Linkages
ATUSC1	ADAPTER	ATUNP
	ADAPTERS	ATUNW
	SC	ATUCD
	SC1	ATUSS
	SCANNER SCANNERS	
ATUID	ID	ATUEP
	IPDETAIL ¹	ATUFA
		ATUFI
		ATUIA
		ATUIL
		ATUIR
		ATUTI
		ATUTP1 ATUTP2
ATUSC4	CSS	ATUNW
	ODLC	ATUCD
	SC4	ATUSS
	3746	ATUSC1
	3746900	ATUSC2 ATUSC3

¹ From ATUIS or ATUIX only.

For more details about how to get to panel ATUSC1, see “ATUSC1 Channel Adapters Panel” on page 4-230.

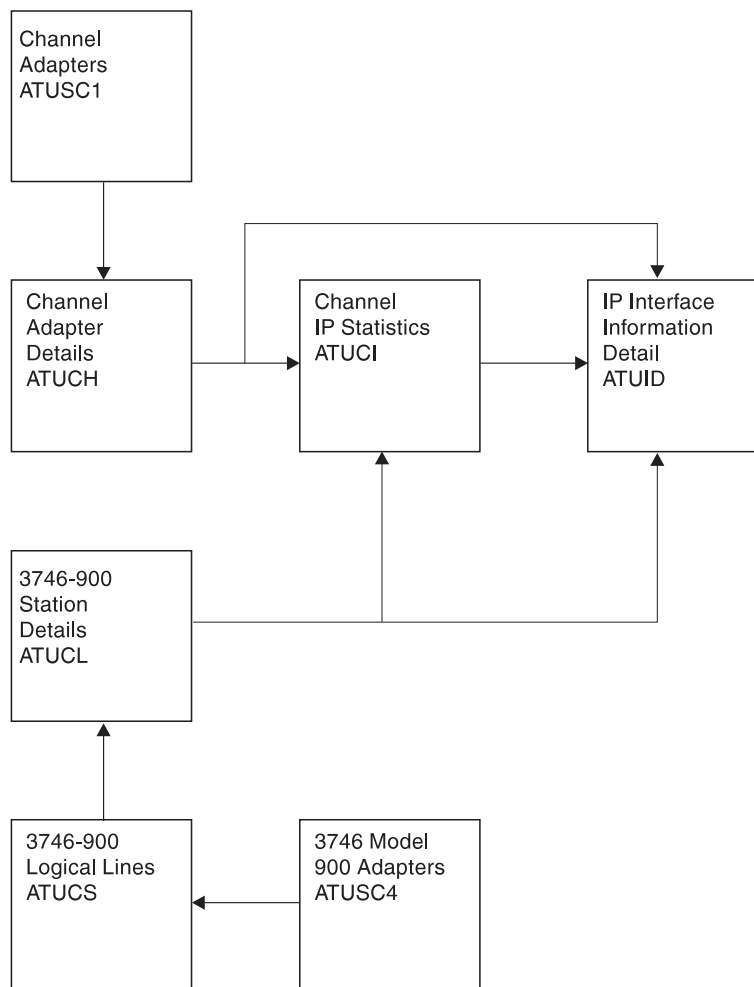

Figure 1-4. Channel Adapters Panel Flow

Frame-Relay Panel Group

The frame-relay panel group can be entered through panel ATUFC.

Table 1-5. Frame-Relay Panel Entry Points

Entry Point	Fast-Path Commands	External Panels with PF-Key Linkages
ATUFC	FC framereley	ATUNP ATUCD ATUNW ATUSS ATUSC2 ATUSC3 ATUSC4

For more details about how to get to panel ATUFC, see “ATUFC Physical Line List Panel” on page 4-94.

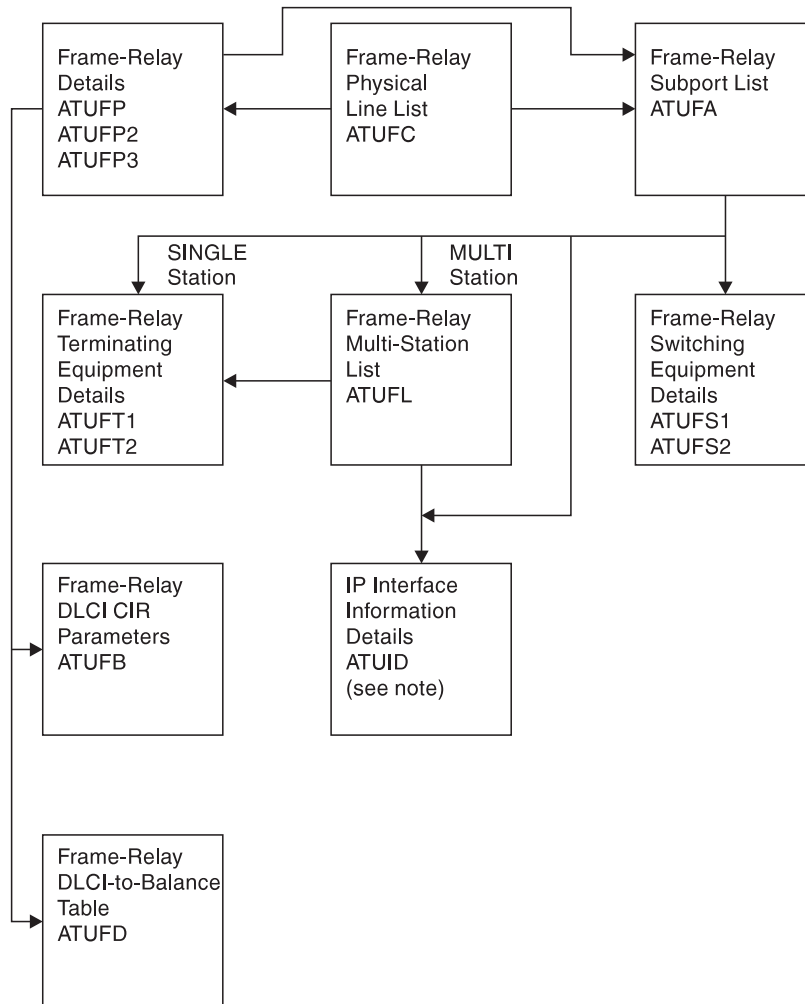

Figure 1-5. Frame-Relay Panel Flow

Note: Panel ATUID is in the IP panel group, as shown in Figure 1-6 on page 1-11.

IP Panel Group

The IP panel group can be entered through either panel ATUIL or panel ATUIS.

Table 1-6. IP Panel Entry Points

Entry Point	Fast-Path Commands	External Panels with PF-Key Linkages
ATUIL	IPLIST IL	None
ATUIS	IP	ATUNP ATUCD ATUNW ATUSS ATUEP ATUET

For more details about how to get to panel ATUIL, see “ATUIL IP Interface Information Panel” on page 4-169. For more details about how to get to panel ATUIS, see “ATUIS IP Router Statistics Page 1 Panel” on page 4-175.

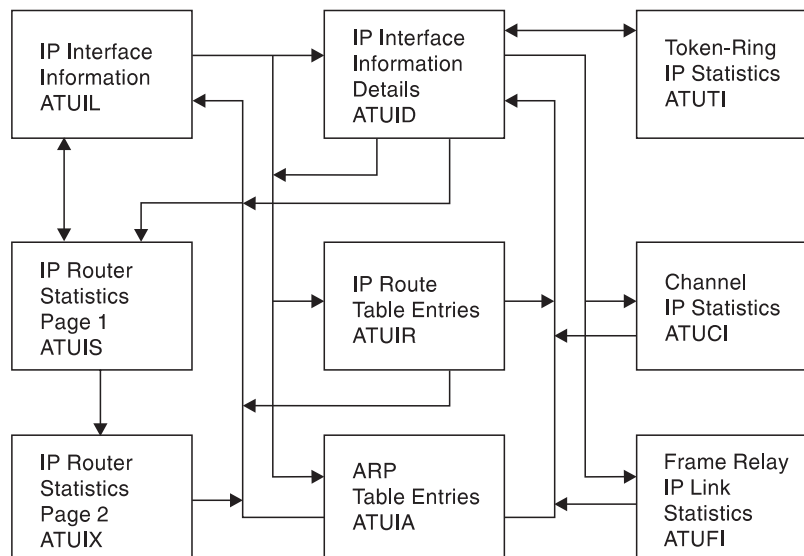

Figure 1-6. IP Panel Flow

SDLC Panel Group

The SDLC panel group can be entered through panel ATUFC.

Table 1-7. SDLC Panel Entry Points

Entry Point	Fast-Path Commands	External Panels with PF-Key Linkages
ATUFC	SDLC	ATUNP ATUCD ATUNW ATUSS ATUSC2 ATUSC3 ATUSC4

For more details about how to get to panel ATUFC, see “ATUFC Physical Line List Panel” on page 4-94.

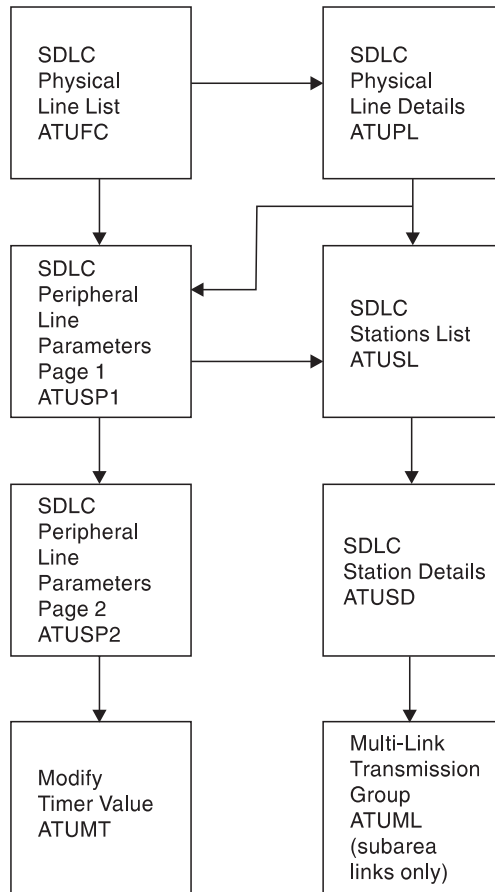

Figure 1-7. SDLC Panel Flow

Token-Ring Panel Group

The Token-Ring panel group can be entered through panel ATUTC.

Table 1-8. Token-Ring Panel Entry Points

Entry Point	Fast-Path Commands	External Panels with PF-Key Linkages
ATUTC	TR tokenring	ATUNP ATUCD ATUNW ATUSS ATUSC1 ATUSC2 ATUSC3 ATUSC4

For more details about how to get to panel ATUTC, see “ATUTC Token-Ring Adapter List Panel” on page 4-278.

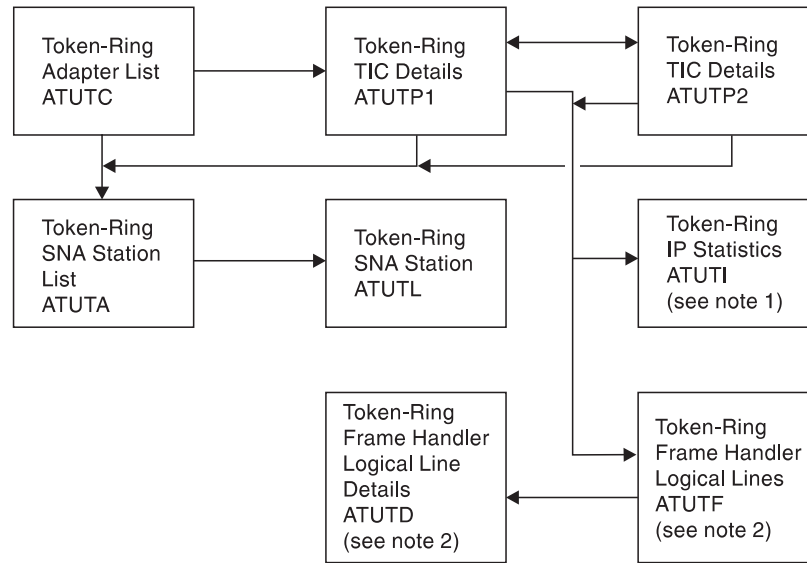

Figure 1-8. Token-Ring Panel Flow

Notes:

1. Panel ATUTI is in the IP panel group, as shown in Figure 1-6 on page 1-11.
2. Panels ATUTD and ATUTF access the frame-relay panel group, which is shown in Figure 1-5 on page 1-10, via panel ATUFA.

Virtual Routes Panel Group

The virtual-routes panel group can be entered through panel ATUVR.

Table 1-9. Virtual-Route Panel Entry Points

Entry Point	Fast-Path Commands	External Panels with PF-Key Linkages
ATUVR	VR VRS VRB	ATUNP ATUNW ATUCD ATUSS

For more details about how to get to panel ATUVR, see “ATUVR Virtual Route Panel” on page 4-334.

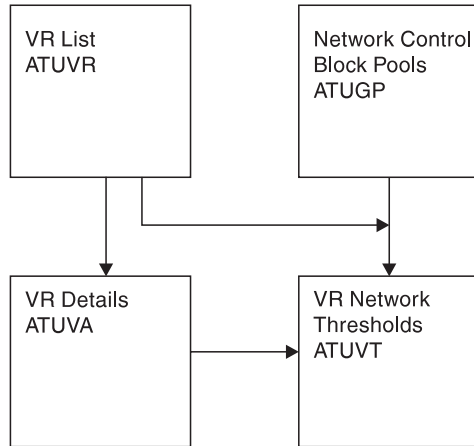

Figure 1-9. Virtual Routes Panel Flow

X.25 Panel Group

The X.25 panel group can be entered through panel ATUXL.

Table 1-10. X.25 Panel Entry Points

Entry Point	Fast-Path Commands	External Panels with PF-Key Linkages
ATUXL	MCH NPSI X25 X25NPSI NPSIX25	ATUNP ATUNW ATUCD

For more details about how to get to panel ATUXL, see “ATUXL X.25 MCH Physical Line List Panel” on page 4-350.

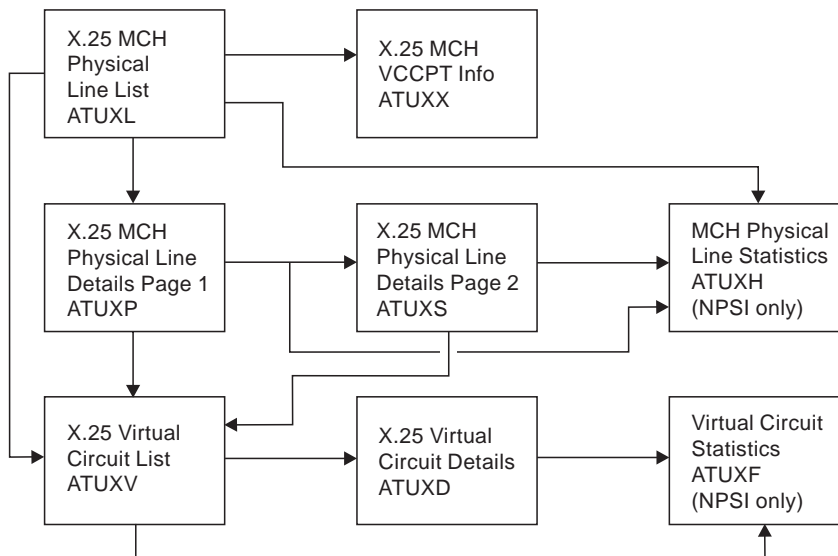

Figure 1-10. X.25 Panel Flow

ISDN Panel Group

The ISDN panel group can be entered through panel ATUDL.

Table 1-11. ISDN Panel Entry Points

Entry Point	Fast-Path Commands	External Panels with PF-Key Linkages
ATUDL	DL ISDN	ATUNP ATUNW ATUCD

For more details about how to get to panel ATUDL, see “ATUDL ISDN Physical Line Table Panel” on page 4-59.

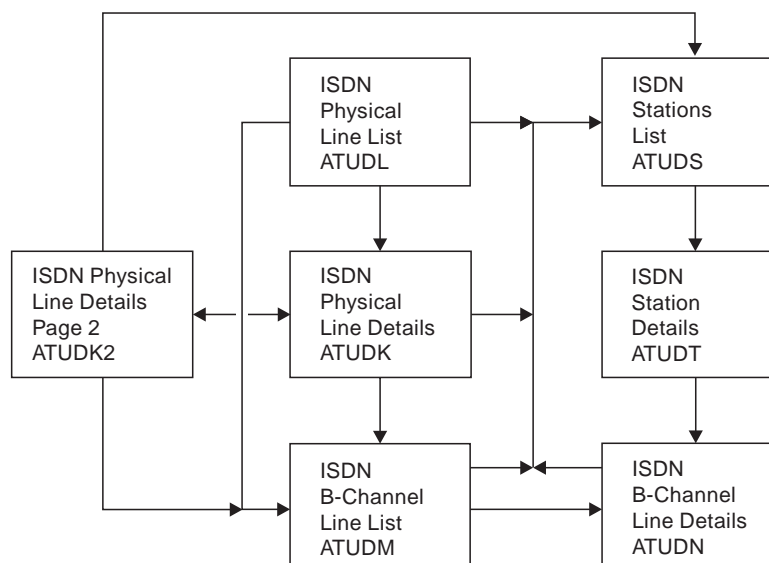

Figure 1-11. ISDN Panel Flow

NTuneNCP

NTuneNCP, used with NTuneMON, enables you to interactively tune NCP without the need for regenerating and reloading. NTuneNCP is responsible for receiving change requests, altering key NCP fields, and logging the changes in a trace table. See the ATUNI NTuneNCP Information panel, as shown on page 4-199, for details. These functions are available for various NCP versions and releases. For more information, refer to “Software Requirements” on page 5-4.

The fields that can be modified are listed by NCP keyword and grouped by function in Table 1-12 on page 1-16.

Table 1-12 (Page 1 of 3). Modifiable NCP Functions

Function	NCP Keywords
Frame-Relay Physical Line	ANSTONE
	CIR
	CLLM
	CRATEDLY
	DSCRDDLY
	DYNWIND
	FRRATES
	FRSPRI
	HLOQSTOP
	IPQLIM
	LMI
	NRZI
	QSIZE
	QSIZEDE
	REDIAL
	RETRIES
	RING
SPEED	
TITIMER	
TRANSBUF	
Frame-Relay Terminating Equipment	BLOCK
	COMRATE
	DYNWIND
	FRSPRI
	LOCALTO/T1TIMER
	MAXDATA
	MAXOUT
	PIUCHECK
TGCONF	
T2TIMER	
Frame-Relay Switching Equipment	COMRATE
	FRSPRI
ISDN Physical Line	CIR
	CRATEDLY
	DSCRDDLY
	FRSPRI
	HLOQSTOP
	QSIZE
QSIZEDE	
ISDN Logical Line	FRSPRI
	PIUCHECK
Multilink Transmission Group	ERn
	MLTGPRI
	TGTIMER
SDLC Physical Line Configuration	ANSTONE
	CCLID
	CLOCKNG
	DATRATE
	DUPLEX
	HISPEED
	NEWSYNC
	NRZI
	RING
	SPEED
	TRANSFR
USE	
X21NTWK	

Table 1-12 (Page 2 of 3). Modifiable NCP Functions

Function	NCP Keywords
SDLC Physical Line Error Recovery Processing	ACTIVTO ETRATIO REDIAL REPLYTO RETRYTO RETRIES RNRLIMIT SRETRY TEXTTO XMITDLY
SDLC Physical Line Performance and Tuning	HDXSP LSPRI PAUSE SERVLIM
SDLC Station	BLOCK MAXDATA MAXOUT/MODULO PASSLIM PIUCHECK RETRIES TGCONF
High Performance Routing	HPRATT HPRMLC HPRMPS HPRQLIM
Session Pacing	ADPLIMIT GWPACING
Virtual Route	TGTIMER VRPWSnm VRTIMERn
Pools	DYNPOOL IPPOOL QSZALERT
Token-Ring TIC	BALANCE DYNWIND LOCADD TITIMER
NTRI Frame Handler Logical Line Details	ADDR ¹ COMRATE LMI
Token-Ring SNA Station	ADDR BLOCK DYNWIND LOCALTO/T1TIMER MAXDATA MAXOUT PIUCHECK REMOTTO/T1TIMER SSAP TGCONF T2TIMER UNIQUE
IP Interface Information Details	ARPTAB

Table 1-12 (Page 3 of 3). Modifiable NCP Functions

Function	NCP Keywords
NCP Function Activation	HPRSNAP
	IPSNAP
	NCPTRACE
	NTRISNAP
	NTUNECOL
X25SNAP	
X.25 Physical Line	CLOCKNG
	NRZI
	SPEED

¹ Only the MAC address portion of the ADDR keyword value can be modified.

You can use NTuneMON with NTuneNCP to modify any of these values. Refer to Chapter 5, "Using the NTuneNCP Tuning Feature" on page 5-1 for additional information.

Chapter 2. Introducing NTuneMON

Understanding NTuneMON	2-3
Setting Up NTuneMON	2-5
Determining Hardware and Software Requirements	2-5
Hardware Requirements	2-5
Software Requirements	2-5
Requirements for Analyzing Certain NCP Resources	2-5
Installing NTuneMON	2-8
MVS	2-8
VM	2-9
Authorizing NTuneNCP Users to NTuneMON	2-9
Using ATUNELST CLIST	2-9
Using the ATUNELST Authorized Users' List	2-11
Using NTuneMON Online Help	2-11
Starting NTuneMON	2-12
Starting NTuneMON from the NetView Command Line	2-12
Specifying NCPs to Monitor	2-12
Starting NTuneMON Automatically	2-13
NTuneMON Command Options	2-13
OUTPUT Option	2-15
ADDR Option	2-15
DEBUG Option	2-16
FAST Option	2-17
GENALERT Option	2-17
GLOBAL Option	2-18
HEX Option	2-19
NETWORK Option	2-19
RESET Option	2-19
SCOPE Option	2-20
SUBAREA Option	2-21
TGN Option	2-21
TYPE Option	2-21
Solving NTuneMON Problems	2-25
NTuneMON or Panels Are Not Found	2-25
NTuneMON Cannot Find a Particular NCP	2-25
NTuneMON Produces Unexpected Output	2-26
NTuneMON Startup Is Slow	2-26
NTuneMON Failure at Startup	2-26
NTuneMON Takes a Long Time to Display Information	2-27
NTuneMON Runs Short of NetView Storage	2-27
NTuneMON Times Out	2-27
NTuneMON Does Not Issue Generic Alerts	2-27
NTuneMON Does Not Analyze Transmission Groups	2-28

NTuneMON is a NetView CLIST that provides current information on a wide variety of NCP resources. This chapter describes how to use NTuneMON and includes the following topics:

- Understanding NTuneMON
- Setting Up NTuneMON
- Using NTuneMON online help
- Starting NTuneMON
- Solving NTuneMON problems

Note: If you plan to tune your NCPs, you must include the NTuneNCP tuning feature. For more information on setting up NTuneNCP, see Chapter 5, “Using the NTuneNCP Tuning Feature” on page 5-1. If you do not have NTuneNCP included, some NTuneMON panels might look different or might not be displayed. For example, when you start NTuneMON, you receive a message about tuning authority (if a default is used in your setup or if you are on the list of operators with authority to tune) although NTuneNCP might or might not actually be included and operating.

Understanding NTuneMON

NTuneMON is a REXX CLIST that runs under the NetView program in a host attached to one or more NCPs. NTuneMON monitors the resources of NCPs activated by VTAM in the host where NTuneMON is running. Figure 2-1 shows the location of NTuneMON in the network.

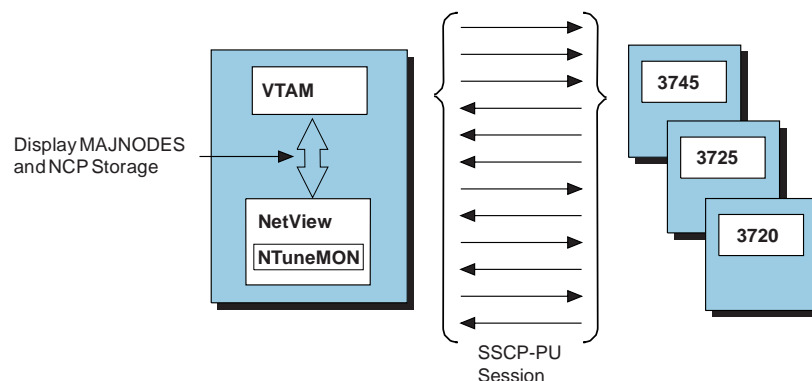

Figure 2-1. Location of NTuneMON in the Network

NTuneMON can provide information in the following ways:

- NTuneMON can display information on NCP resources through a set of interactive panels. Each panel provides information on a particular aspect of NCP, such as virtual routes, transmission groups, or control block pools.
- NTuneMON can send information on NCP resources to the current NetView screen or to the NetView log.
- NTuneMON can send generic alerts indicating possible network problems to the Network Problem Determination Application (NPDA) component of NetView.

You start NTuneMON from the NetView command line. While using NTuneMON interactively, you can move from one panel to another by entering commands on the command line of any panel or by pressing the programmed function keys (PF keys) indicated on the panels. You can press the PF keys to perform various func-

tions in each panel, and you can control some aspects of NTuneMON (such as warning thresholds) by entering values in certain panel fields. NTuneMON informs you of errors and other conditions by displaying messages on the command line of the current panel or by returning you to the Network Communication Control Facility (NCCF) screen of NetView.

NTuneMON alerts you to conditions that might require attention (such as depleted resources) by highlighting certain panel fields in color. It is recommended that you use a color terminal to take full advantage of the information that NTuneMON provides.

Table 2-1 shows the types of NCP resources NTuneMON monitors and gives a few examples of each type. For more details on particular types of resources, refer to Chapter 4, “Using NTuneMON Panels for Monitoring” on page 4-1.

Table 2-1. NCP Resources Monitored by NTuneMON

Resource	Example
NCP configuration	NCP release, generation date and time, subarea address, and usage tier
Communication controller configuration	Controller model, storage size, operating mode, and MOSS EC and FIX levels
Processing and storage	Use of CCU cycles and NCP buffers and display of NCP storage in dump format
NCP control blocks	Size and use of many NCP control block pools
Virtual routes	Window sizes, traffic rates, and congestion
High performance routes	Flow control and traffic rates
Pools	Control blocks, buffer slowdown information
Transmission groups	Type, status, queue sizes, and multilink transmission groups
Cross-network resources	Network names table, half-session control blocks (HSCBs), and gateway network addressable units (GWNAUs)
IBM 3745 channel and line adapters	Type, address, status, and IP statistics
Token-Ring resources	Token-Ring interface couplers (TICs), physical and logical lines, stations, routes, and IP statistics
Internet Protocol (IP) and Ethernet-type LAN resources	Ethernet-type adapter status, frame and datagram counts, and traffic rates
Frame-relay resources	Physical and logical lines, frame counts, traffic rates, LMI statistics, DLCIs, subports, and IP statistics
3746 Model 900 connectivity subsystem (CSS) resources	Token-Ring, ESCON adapters, ESCON logical lines and stations, Communication Line Processor (CLP) adapters, synchronous data link control (SDLC) lines and stations, and IP statistics for ESCON resources
SDLC resources (transmission subsystem (TSS), high performance transmission subsystem (HPTSS), and CSS)	SDLC lines and station lists with statuses and key configuration information
X.25 resources	MCH physical lines and virtual circuits, status, configuration information, and statistics
ISDN resources	Physical lines, B-channels, and stations
Pre-SNA resources	Bisync, start-stop, and PEP line and device details

If you need information on line utilization, refer to the *NetView Performance Monitor At a Glance* publication.

Setting Up NTuneMON

This section describes how to set up NTuneMON. It covers the following topics:

- Determining hardware and software requirements
- Installing NTuneMON
- Authorizing NTuneNCP Users to NTuneMON

For more information regarding setting up NTuneNCP, see Chapter 5, “Using the NTuneNCP Tuning Feature” on page 5-1.

Determining Hardware and Software Requirements

This section describes the hardware and software required to run NTuneMON and to analyze certain types of NCP resources.

Hardware Requirements

Host: NTuneMON must reside on the VTAM host that activates the NCPs to be monitored.

Terminal: Because NTuneMON uses color to highlight certain panel fields, it is recommended that you use a color terminal to take full advantage of the information NTuneMON provides. To get full color support, be sure to use the proper LOGMODE as described in the *NetView Samples* publication.

Software Requirements

To use NTuneMON, you need the following software:

- VTAM
- NetView 2.3 or higher
- REXX 2.4 or later

Notes:

1. See the *NTuneMON Program Directory* for a list of VTAM and NetView supported releases.
2. To support VTAM USE, you need VTAM V4R2 with the appropriate maintenance.

NTuneMON displays and monitors the resources of NCP releases V4R3.1 and later.

You also need to specify STORDSP as a value for the OPTIONS keyword on the NCP SYSCNTRL statement. See *NCP, SSP, and EP Resource Definition Reference* for more information.

Requirements for Analyzing Certain NCP Resources

Although you can use NTuneMON with an IBM 3720, IBM 3725, or IBM 3745 Communication Controller and with any supported release of NCP V4, NCP V5, NCP V6, or NCP V7, you need NCP V4R3.1 or a later release, an IBM 3745 Communication Controller, or the 3746 Model 900 connectivity subsystem (CSS) to analyze certain NCP resources. Table 2-2 on page 2-6 lists some of these requirements.

Setting Up NTuneMON

Table 2-2 (Page 1 of 3). Requirements for Analyzing Certain NCP Resources

NCP Resource to Be Analyzed	Primary NTuneMON Panel	Page	Minimum NCP Release	Hardware Required
Date and time of last CDS update	ATUCD CDS NCP Selection	4-27	V5R3	3745
CCU operating mode	ATUCD CDS NCP Selection	4-27	V5R3	3745
Scanners	ATUSC1 Channel Adapters	4-230	V5R3	3745
Microcode EC and FIX levels	ATUCD CDS NCP Selection	4-27	V5R3	3745
Control blocks: LUB, LND, LNB, BSB, LTX, NNT, NSC, NSX	ATUCB Control Block Pools/Tables	4-17	V4R3.1	3725, 3745
Control block: IPOOL	ATUBP NCP Buffer Pool	4-4	V6R1	3745
Control blocks: LUX and VVT, percent of HCSBs and PUDR in use	ATUCB Control Block Pools/Tables	4-17	V6R2	3745
Control blocks: TR LLB, FR LLB, HRE, NRE, SRE, FCT, NQE, NQX, NSB, RVT, NVT, and SNP	ATUCB Control Block Pools/Tables	4-17	V7R1	3745
Control block: ODLC LAN	ATUCB Control Block Pools/Tables	4-17	V7R1	3746 Model 900
Control block: ODLC FR	ATUCB Control Block Pools/Tables	4-17	V7R2	3746 Model 900
Control blocks: ISDN PN and ISDN SA	ATUCB Control Block Pools/Tables	4-17	V7R5	3746 Model 900
Dynamic control blocks	ATUCB Control Block Pools/Tables	4-17	V7R1	3745
Control blocks: first failure data capture	ATUBS Buffer Slowdown Information Page 1	4-10	V7R5	3745
Multilink transmission groups	ATUML Multi-Link Transmission Group	4-184	V4R3.1	3725, 3745
NCP/Token-Ring Interconnect (NTRI) resources	ATUTP1 Token-Ring TIC Details Page 1	4-310	V5R4	3745
3746 Model 900 Token-Ring resources	ATUTC Token-Ring Adapter List	4-278	V6R2	3746 Model 900
Ethernet-type adapters	ATUEP Ethernet Adapter List	4-81	V6R1	3745
IP statistics: IP datagrams and ICMP message counts	ATUIS IP Router Statistics Page 1	4-175	V6R1	3745
IP statistics: UD datagram counts and owning TCP/IP host information	ATUIX IP Router Statistics Page 2	4-180	V7R1	3745
IP statistics for Token Ring	ATUTI Token-Ring IP Statistics	4-298	V7R1	3745

Table 2-2 (Page 2 of 3). Requirements for Analyzing Certain NCP Resources

NCP Resource to Be Analyzed	Primary NTuneMON Panel	Page	Minimum NCP Release	Hardware Required
IP statistics for channel	ATUCI Channel IP Statistics	4-36	V7R3	3745
IP statistics for frame relay	ATUFI Frame-Relay IP Link Statistics	4-102	V7R3	3745
IP statistics for ESCON resources	ATUCI Channel IP Statistics	4-36	V7R3	3746 Model 900
Frame-relay subarea TESP	ATUFA Frame Relay Support List	4-88	V6R2	3745
Frame-relay peripheral TESP	ATUFA Frame Relay Support List	4-88	V7R1	3745
Frame-relay IPSP	ATUFA Frame Relay Support List	4-88	V7R3	3745
Frame-relay DLCI CIR	ATUFB Frame Relay DLCI CIR Parameters	4-92	V7R7	3746 Model 900
Frame-relay DLCI balancing factors	ATUFD Frame Relay DLCI to Balance Table	4-99	V7R7	3745
NTRI frame handler logical lines	ATUTF NTRI Frame Handler Logical Lines	4-291	V7R3	3745
3746 Model 900 frame-relay resources	ATUFP Frame Relay Physical Line Details Page 1	4-108	V7R2	3746 Model 900
Frame-relay switching (FRSE) resources	ATUFS1 Frame Relay Switching Equipment Page 1	4-127	V6R2	3745
ESCON resources	ATUCS 3746-900 Logical Lines	4-43	V6R2	3746 Model 900
3746 Model 900 Communication Line Processor (CLP)	ATUSC4 3746 Model 900 Adapters	4-237	V6R2	3746 Model 900
HPR resources	ATUHP HPR & Other Global Flow Control Params	4-153	V7R3	3745
3746 Model 900 X.25 resources	ATUXL X.25 MCH Physical Line List	4-350	V7R4	3746 Model 900
NPSI X.25 resources (NPSI V3R7 or later)	ATUXL X.25 MCH Physical Line List	4-350	V7R2	3745
ISDN resources	ATUDL ISDN Physical Line Table	4-59	V7R5	3746 Model 900
Pre-SNA resources	ATUPS Bisync/SS Line Details	4-223	Any	3720, 3725, 3745

Setting Up NTuneMON

Table 2-2 (Page 3 of 3). Requirements for Analyzing Certain NCP Resources

NCP Resource to Be Analyzed	Primary NTuneMON Panel	Page	Minimum NCP Release	Hardware Required
EP PEP link resources	ATUED PEP Line Details	4-78	Any	3720, 3725, 3745

Installing NTuneMON

To install NTuneMON, you need to make the ATUNEMON CLIST and panels available to the NetView program. The following sections describe how to do this in MVS and VM.

Note: The name of the CLIST for NTuneMON is ATUNEMON CLIST.

For more information on installing NTuneMON, refer to the *NTuneMON Program Directory* for your operating system. IBM supplies Program Directories with the tapes that contain each product.

MVS

To make the ATUNEMON CLIST and panels available to the NetView program in MVS, you can either add the NTuneMON libraries to your NetView procedure or add the ATUNEMON CLIST and panel members to existing libraries.

Adding NTuneMON Libraries to Your NetView Procedure: To add the NTuneMON libraries to your NetView procedure:

- Add SATULST1 (the CLIST library) to the DSICLD DD concatenation stream.
- Add SATUPNL1 (the panel library) to the CNMPNL1 DD concatenation stream.
- Restart the NetView program.

You can assign your own high-level qualifier to the NTuneMON library data set names. Be sure your NetView procedure specifies the fully qualified data set names.

Adding the ATUNEMON CLIST and Panel Members to Existing Libraries: To add the ATUNEMON CLIST and panel members to existing libraries:

- Copy the files (CLIST members) in SATULST1 (the CLIST library) into an existing CLIST library.
- Copy the files (panel members) in SATUPNL1 (the panel library) into an existing panel library.

You do not need to restart the NetView program.

Compiling NTuneMON: MVS users can compile NTuneMON and execute it as a compiled REXX EXEC. To compile NTuneMON,

1. Remove the bottom eight lines of ATUNEMON CLIST.
2. Ensure that SETVAR is link-edited into the REXX functions library.
3. Compile the CLIST using the MVS REXX Compiler.

For specific instructions about compiling a REXX EXEC, see *IBM REXX Compiler and Library/370: User's Guide and Reference*.

VM

To make the NTuneMON file and panels available to the NetView program in VM, make sure the NetView program has access to the disk on which the NTuneMON files reside. The file type of NTuneMON files is NCCFLST.

Authorizing NTuneNCP Users to NTuneMON

An ATUNELST CLIST file is provided with NTuneMON and contains the correct format for authorizing NTuneNCP users, as well as the default values for various NTuneMON parameters and threshold values. You need to install this file in a protected dataset so that only designated users can access it.

Note: Even if you are not going to use NTuneNCP, you still need to install the ATUNELST.

You should make a working copy of the ATUNELST CLIST and save the original as backup. Make all your changes to the working copy. If a problem arises, you will still have the original ATUNELST CLIST. It is also recommended that you test your changes before making them permanent.

There is a section in ATUNELST that indicates that no changes should be made below a certain point. If you change anything below this point, you might affect the operation of NTuneMON.

ATUNELST lets you preset the threshold values and set up users who are authorized to change NCP parameters. The CLIST is listed by control block name for each available pool. Comments in the CLIST indicate the purpose of the variables. For control block pool thresholds, the name of the control block appears in the comment.

Using ATUNELST CLIST

The format of the alarm threshold is as follows:

```
varname = 'xxx=???'          /* comment
```

xxx is an indicator and should not be changed. If you change the indicator, your information will not be processed. ??? is the current alert threshold value. Valid values range from 0 to 999. xxx=??? must be enclosed in single quotation marks (' '). An example of the range format follows:

```
DALM.11      = 'BU11=101' /* NCP buffers in use
```

Note: Code THST=NO if you do not want message number ATUM119 to display. However, coding THST=NO does not prevent threshold setting. YES is the default.

For additional information, refer to the *NTuneMON Program Directory* for your operating system. IBM supplies Program Directories with the tapes that contain each product.

Figure 2-2 is an example of ATUNELST CLIST data.

```
DSTART      = 'THRESHOLD' /* START OF THE ALARM THRESHOLD
DPRINT      = 'THST=YES' /* PRINT MESSAGE, YES OR NO
DMAXAUTO    = 'FMXA=500' /* SIZE WHICH FAST=AUTO KICKS IN
DTGBALARM   = 'TGBA=100' /* TG queues %
DVRALARM    = 'VRAL=100' /* VR INBOUND QUEUE %
DALM.1      = 'LU01=80' /* LUB in use LUDR
DALM.2      = 'LN02=80' /* LNB in use
DALM.3      = 'LN03=80' /* LND in use
DALM.4      = 'NS04=80' /* NSC in use
DALM.5      = 'BS05=80' /* BSB in use
DALM.6      = 'LT06=80' /* LTX in use
DALM.7      = 'NS07=80' /* NSX in use
DALM.8      = 'NU08=80' /* NUMHSAS in use
DALM.9      = 'BP09=62' /* BPOOL LOW PRIORITY
DALM.10     = 'NT10=80' /* NNTS
DALM.11     = 'BU11=101' /* NCP buffers in use
DALM.12     = 'IP12=75' /* IPPOOL
DALM.13     = 'TL13=80' /* Token-Ring logical lines
DALM.14     = 'CU14=80' /* CUBS (PUDR)
DALM.15     = 'LU15=80' /* LUX
DALM.16     = 'NX16=80' /* HSCBS NIX/NLX
DALM.17     = 'VV17=80' /* VVTS (VRBS)
DALM.18     = 'OL18=80' /* ODLC LAN
DALM.19     = 'NQ19=80' /* NXQ
DALM.20     = 'NS20=80' /* NSB
DALM.21     = 'RV21=80' /* RVT
DALM.22     = 'TR22=80' /* TR LLB
DALM.23     = 'FR23=80' /* FR LLB
DALM.24     = 'FC24=80' /* FCT
DALM.25     = 'NV25=80' /* NVT
DALM.26     = 'NQ26=80' /* NQE
DALM.27     = 'SN27=80' /* SNP (VTS)
DALM.28     = 'HR28=80' /* HRE
DALM.29     = 'NR29=80' /* NRE
DALM.30     = 'GW30=80' /* GWNAUS
DALM.31     = 'SR31=80' /* SRE
DALM.32     = 'DD32=101' /* Dynpool
DALM.33     = 'NG33=80' /* Network GWNAUs
DALM.34     = 'NT34=80' /* Network TGBs
DALM.35     = 'NW35=80' /* Network TRTs
DALM.36     = 'VR36=80' /* VRB
DALM.37     = 'CT37=80' /* Channel TG
DALM.38     = 'LT38=80' /* Link TG
DTGBMAX     = 'TGBM=40' /* Max number of TGs to SEARCH
DALMSTP     = 'ENDALR' /* DO NOT REMOVE THIS INDICATOR
```

Figure 2-2. Example of ATUNELST CLIST Data

Using the ATUNELST Authorized Users' List

Be sure to change the count field to reflect the total number of users in the list. AUTHSTAR and AUTHEND must be included in this total. *ALL* is the default and will give all operators who use NTuneMON the ability to make tuning changes in NCP. To restrict access, code only those operator IDs that will have this function available to them. Remove *ALL* from AUTH.1 if you are going to assign user IDs. All operator IDs must be enclosed in quotes. Up to 50 operator IDs are allowed in this file. To increase the number of operators to 50 (in Figure 2-3), use the following format:

```
AUTH.XX (AUTH.21 thru AUTH.50)
```

Figure 2-3 is an example of the authorized users' list.

```
AUTHSTAR = 'AUTHSTAR'      /* DO NOT REMOVE THIS INDICATOR
AUTHCNT  = '22'           /* ENTER Number of IDs in the list
AUTH.1   = 'ALL'         /* ENTER OPERATOR ID
AUTH.2   = ' '           /* ENTER OPERATOR ID
AUTH.3   = ' '           /* ENTER OPERATOR ID
AUTH.4   = ' '           /* ENTER OPERATOR ID
AUTH.5   = ' '           /* ENTER OPERATOR ID
AUTH.6   = ' '           /* ENTER OPERATOR ID
AUTH.7   = ' '           /* ENTER OPERATOR ID
AUTH.8   = ' '           /* ENTER OPERATOR ID
AUTH.9   = ' '           /* ENTER OPERATOR ID
AUTH.10  = ' '           /* ENTER OPERATOR ID
AUTH.11  = ' '           /* ENTER OPERATOR ID
AUTH.12  = ' '           /* ENTER OPERATOR ID
AUTH.13  = ' '           /* ENTER OPERATOR ID
AUTH.14  = ' '           /* ENTER OPERATOR ID
AUTH.15  = ' '           /* ENTER OPERATOR ID
AUTH.16  = ' '           /* ENTER OPERATOR ID
AUTH.17  = ' '           /* ENTER OPERATOR ID
AUTH.18  = ' '           /* ENTER OPERATOR ID
AUTH.19  = ' '           /* ENTER OPERATOR ID
AUTH.20  = ' '           /* ENTER OPERATOR ID
AUTHSEND = 'AUTHEND'     /* DO NOT REMOVE THIS INDICATOR
```

Figure 2-3. Example of the Authorized Users' List

Using NTuneMON Online Help

Press F1 from any NTuneMON panel to view the Main Help for the panel. The Main Help panel for an NTuneMON panel provides Help for that panel, including:

- Help for Fields. This help provides an explanation of every field on the panel.
- Help for PF Keys. This help provides an explanation of the PF keys.
- Help for Tuning. This help is available if there are tuning fields on the panel. This help provides detailed tuning help, including:
 - Explanation of the tuning field
 - NCP keyword to which the tuning field corresponds
 - NDF default value
 - Valid NTune tuning values
 - Tuning considerations

Starting NTuneMON

- Tuning suggestions
- Help for Modify. This help is available if there are tuning fields on the panel. This help explains how to modify tuning fields.

The Main Help for an NTuneMON panel also provides the following Basic Help:

- Help for Help, which explains how to use the help and the color conventions used in the help panels.
- Help for Basic Fast-Path Commands. This help shows you the fast-path commands you can enter from any NTuneMON panel to go to a given NTuneMON panel.
- Help for Messages, Generic Alerts, and the Startup Command.

Note: You can also get help for information and error messages by typing HELP and the message number (for example, help atum001) from the command line of any NTuneMON panel.

- Main Help. This help provides an introduction to NTuneMON and NTuneNCP. It also provides another way to access the Helps for NTuneMON panels.

Starting NTuneMON

There are two ways to start NTuneMON: from the NetView command line and automatically.

Starting NTuneMON from the NetView Command Line

To start NTuneMON, enter **ATUNEMON** on the NetView command line. As you begin using NTuneMON, it is recommended that you start by using the panels first. When you use the NTuneMON panels, you can choose to use the defaults that are shipped with the panels. For more information on command options, refer to “NTuneMON Command Options” on page 2-13.

Note: If you prefer to invoke NTuneMON using the word **NTUNEMON** instead of **ATUNEMON**, update DSICMD using CMDSYN NTUNEMON after the statement for ATUNEMON.

The rest of this section describes how to control various characteristics of NTuneMON when you start it.

Specifying NCPs to Monitor

By default, NTuneMON monitors all NCPs activated by the host in which NTuneMON is running. To identify all active NCPs, NTuneMON first issues VTAM commands to display all major nodes (D NET,MAJNODES). NTuneMON then issues NCPSTOR commands (D NET,NCPSTOR) for all type 4 and type 5 physical unit resources. All physical units that respond positively and are NCP V4, V5, V6, or V7 are considered to be active NCPs.

A great deal of processing is required to monitor a large number of active NCPs. If you have many active NCPs, you can improve NTuneMON performance by monitoring only certain NCPs. When you start NTuneMON, you can specify NCP names to force NTuneMON to monitor certain NCPs, or to prevent it from monitoring certain NCPs.

Notes:

1. Alternately, you can use the FAST startup option to improve performance with many NCPs.
2. You might want to use FAST=YES most of the time and use FAST=NO only when you change your network configuration.

To force NTuneMON to monitor only certain NCPs, specify the names of those NCPs after the **ATUNEMON** command. Separate the names with commas or blank spaces. For example, the following command causes NTuneMON to monitor only NCP02, NCP03, and NCP05:

```
ATUNEMON NCP02 NCP03 NCP05
```

To prevent NTuneMON from monitoring certain NCPs, specify the names of those NCPs after the **ATUNEMON** command and precede each NCP name with a dash. Separate the names with commas or blank spaces. For example, the following command causes NTuneMON to monitor all active NCPs except NCP02 and NCP04:

```
ATUNEMON -NCP02 -NCP04
```

Starting NTuneMON Automatically

You can use the NetView EVERY or AT command on your own ID or in an autotask to start NTuneMON at regular intervals or at a specified time. This is a convenient way to check for NCP conditions that might require your attention.

When you start NTuneMON automatically, use the options OUTPUT=NONE and GENALERT=YES. This suppresses the display of NTuneMON information and causes NTuneMON to generate alerts for conditions that might require your attention. Also use the TYPE option to specify the resources you want NTuneMON to monitor.

NTuneMON Command Options

The **ATUNEMON** command has several options that determine various characteristics of NTuneMON. The following diagram shows the syntax of the **ATUNEMON** command and its options. You can specify the options in any order, separated by blank spaces or commas. The following sections describe each option in detail.

Starting NTuneMON

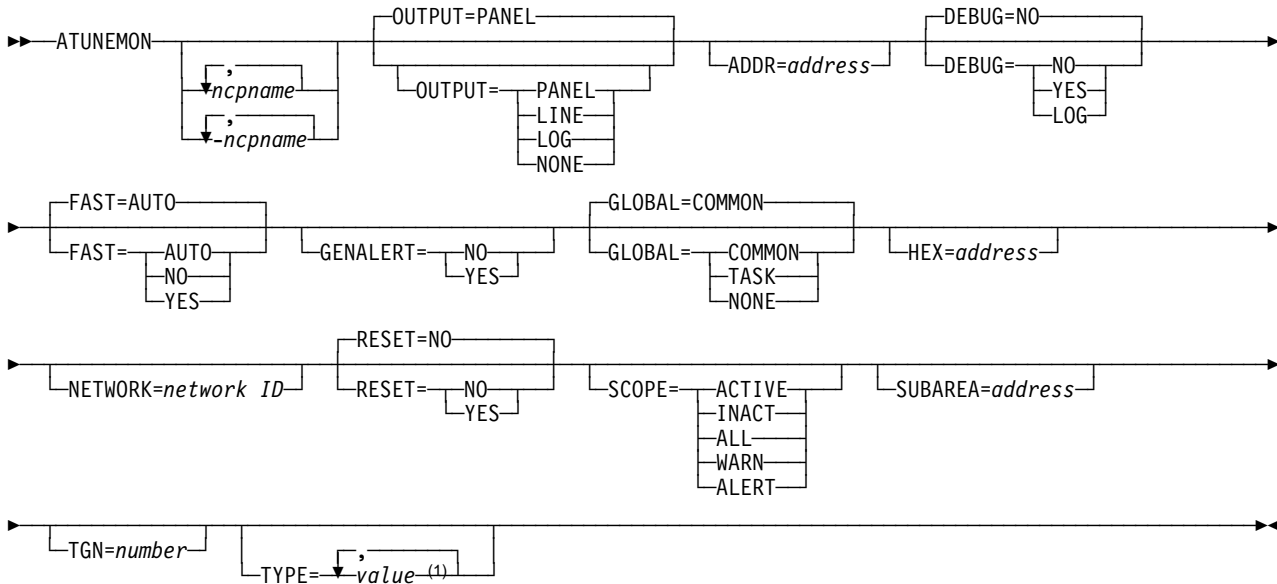

¹ TYPE option values are shown in Table 2-4 on page 2-22.

Figure 2-4. NTuneMON Command Options

Following are two examples of command options. The first example starts NTuneMON and displays the ATUNP NCP Selection panel as shown on page 4-204. The second example copies the ATUBP NCP Buffer Pool panel, as shown on page 4-4, to the network log and, if necessary, issues generic alerts during the snapshot run.

ATUNEMON

ATUNEMON,OUTPUT=LOG,GENALERT=YES,TYPE=BUFFER

If you code no options, the resulting values are:

- ATUNEMON=all ncp names
- OUTPUT=PANEL (TYPE is ignored)
- ADDR=all addresses
- DEBUG=NO
- FAST=AUTO
- GENALERT=NO
- GLOBAL=COMMON
- HEX=all addresses
- NETWORK=all network ids
- RESET=NO
- SCOPE=ACTIVE
- SUBAREA=all addresses
- TGN=all numbers

Note: TYPE is ignored if you specify OUTPUT=PANEL. For more information on TYPE values, see Table 2-4 on page 2-22.

OUTPUT Option

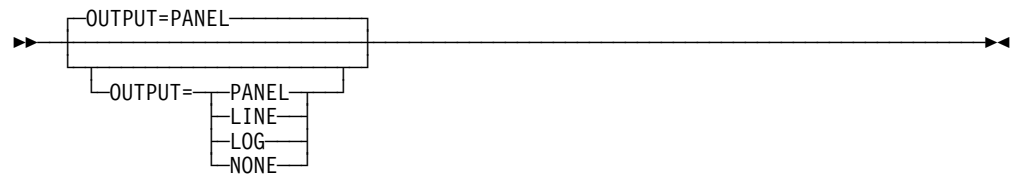

This option determines how NTuneMON information is presented. The default is OUTPUT=PANEL.

PANEL

Presents NTuneMON information in interactive panels.

Note: The TYPE option is ignored when you use OUTPUT=PANEL. For more information on the TYPE values, see Table 2-4 on page 2-22.

LINE

Presents NTuneMON information line by line as messages sent to the NetView screen and the NetView log. With this output mode, you can use your own CLISTs to process NTuneMON information. For more information on these messages, see Chapter 9, “NTuneMON Messages” on page 9-1.

If you specify OUTPUT=LINE, you can also specify the TYPE option. For more information on the TYPE values, see Table 2-4 on page 2-22.

LOG

Presents NTuneMON information line by line as messages sent to the NetView log.

If you specify OUTPUT=LOG, you can also specify the TYPE option. For more information on the TYPE values, see Table 2-4 on page 2-22.

NONE

Suppresses the output of NTuneMON information. In this mode, NTuneMON's only output is the generic alerts issued to indicate possible network problems.

Use the options OUTPUT=NONE and GENALERT=YES when you start NTuneMON automatically with the NetView EVERY or AT command. The NTuneMON GENALERTs are in the NPDA alert file.

If you specify OUTPUT=NONE, you can also specify the TYPE option. For more information on the TYPE values, see Table 2-4 on page 2-22.

ADDR Option

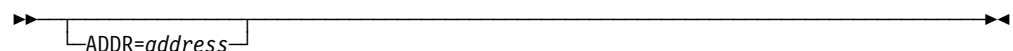

This option causes NTuneMON to analyze only a specific line and the resources attached to it. Code ADDR=nnnn, where nnnn is the address of the line as defined by ADDRESS on the LINE statement.

Table 2-3 on page 2-16 shows the line types for which ADDR is valid, along with the TYPE values for each line type.

Starting NTuneMON

Table 2-3. TYPE Values for Various Line Types

For This Line Type	You Can Specify TYPE=	The Default Is TYPE=
Token-Ring	MAC, IDBLK, CPNAME, LINE, or TP	TP
Ethernet-type LAN	ET	ET
Frame relay	FP, DLCI, FHSP, or TESP	None
ESCON	CSS	CSS
SDLC	PL	None

For example, if you specify TYPE=MAC and ADDR=1088, NTuneMON lists all MAC addresses with logical connections over the Token-Ring physical line at address 1088.

DEBUG Option

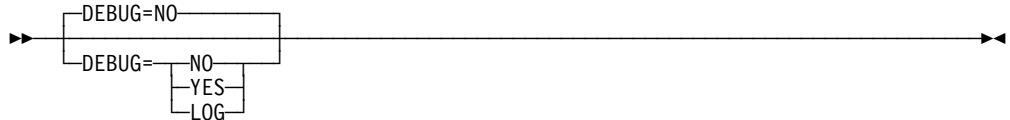

This option controls the NTuneMON debug feature, which traces:

- All commands issued to each NCP
- All responses received from the NCPs
- NetView global variables used by NTuneMON

The default is DEBUG=NO.

NO

Deactivates NTuneMON debug feature.

YES

Activates NTuneMON debug feature and sends all debug information as messages to the NetView screen and the NetView log. These messages are described in “Display Messages” on page 9-14.

Notes:

1. DEBUG=YES can cause NTuneMON to generate many messages. You might wish to specify DEBUG=LOG instead.
2. A nonzero return code for GLOBALV does not indicate an error. This is an indicator to NTuneMON that the NetView function for saving global variables to VSAM (NetView V2R2 or later) is not being used.

LOG

Activates NTuneMON debug feature and sends all debug information as messages to the NetView log.

Note: While NTuneMON is running, you can enter DEBUG on the command line of any panel to turn the debug feature on or off.

FAST Option

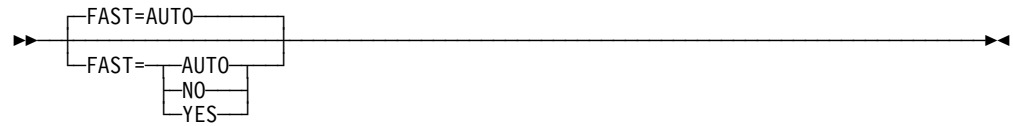

This option improves NTuneMON startup performance by suppressing the D NET,MAJNODES command to identify all active NCPs. Instead, NTuneMON uses the list of active NCPs that is saved in the NetView global variables at the end of each NTuneMON session. The default is FAST= AUTO.

The FAST option is not valid if you specify NCP names in the **ATUNEMON** command.

AUTO

Causes NTuneMON to use FAST= YES when the number of major nodes exceeds 500. Otherwise, NTuneMON uses FAST= NO.

NO

Causes NTuneMON to issue the D NET,MAJNODES command at startup to identify active NCPs.

Note: You might want to use FAST= YES most of the time and use FAST= NO only when you change your network configuration. Nothing is saved by specifying FAST= NO.

YES

Causes NTuneMON to use the list of active NCPs saved as NetView global variables. If no list of NCPs is found, NCP ignores FAST= YES and issues the D NET,MAJNODES command.

When you start NTuneMON with FAST= YES, NTuneMON issues the following message to indicate when the list of active NCPs was last saved:

```
ATUM006 ACTIVE NCP LIST SAVED dd mmm yyyy hh:mm:ss UPDATE WITH FAST=NO
```

GENALERT Option

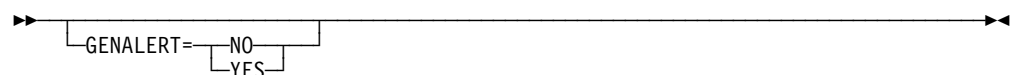

This option specifies whether NTuneMON issues generic alerts to the NetView program to indicate possible problems in the resources NTuneMON is monitoring. If you specify OUTPUT= NONE, the default is GENALERT= YES; otherwise, the default is GENALERT= NO.

NO

Suppresses NTuneMON alerts.

YES

Causes NTuneMON to issue alerts to the NetView program. You can issue the NetView NPDA command to view them.

Starting NTuneMON

Notes:

1. NTuneMON issues the alert only if the alert condition exists when you display the panel or when you press the REFRESH PF key.
2. When running in OUTPUT=LINE, LOG, or NONE modes, the alerts are issued only during the snapshot of the run.
3. While NTuneMON is running, you can enter GENALERT or ALERT on the command line of any panel to turn the generic alert function on or off.
4. A *warning* is a type of alert.

For more information on alerts, see Chapter 8, “NTuneMON Alerts” on page 8-1.

GLOBAL Option

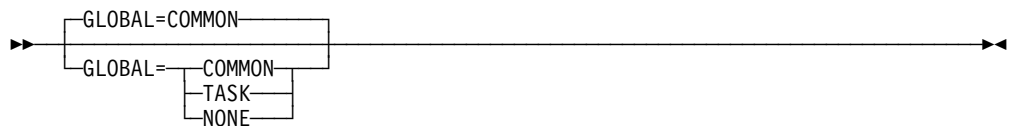

This option specifies whether NTuneMON information is to be saved as NetView global variables, and if so, whether NetView common or task global variables are to be used. The default is GLOBAL=COMMON.

The information saved includes NCP addresses and use thresholds entered into NTuneMON panel fields. Saving this information can reduce NTuneMON startup time for the next session.

Attention: When the NetView program is stopped, all global variables are lost. With NetView V2R2 and later releases, you can save global variables to VSAM to prevent them from being lost.

COMMON

Causes NTuneMON information to be saved as NetView common global variables. Use GLOBAL=COMMON to define the same resource use thresholds for all NetView operator IDs.

TASK

Causes NTuneMON information to be saved as NetView task global variables. Use GLOBAL=TASK to define separate resource use thresholds for each NetView operator ID.

NONE

Prevents NTuneMON information from being saved as NetView global variables. Any values you type in NTuneMON panel fields are discarded when you end your NTuneMON session.

Note: The GLOBAL and RESET options perform complementary functions in determining whether information from one NTuneMON session is used for the next session. GLOBAL determines whether NTuneMON information is saved at the end of a session, and RESET determines whether saved information is used at the beginning of a session or discarded.

HEX Option

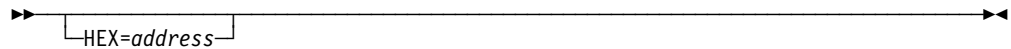

This option causes NTuneMON to display 320 bytes of NCP storage starting at *address* in hexadecimal and EBCDIC dump format. When you specify HEX, OUTPUT=LINE is the default. You can specify OUTPUT=LOG to direct the output to the NetView log.

Using the HEX option is a quick way to view NCP storage. For example, to view the storage of NCP03 starting at address 018168, enter:

```
ATUNEMON NCP03 HEX=018168
```

NETWORK Option

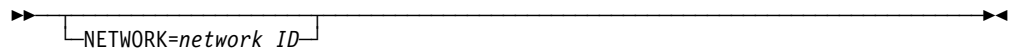

This option causes NTuneMON to monitor the multilink transmission groups or GWNAUs in a specific network. Code NETWORK=*nnnnnnnn*, where *nnnnnnnn* is a network ID. This option is valid only when you specify the TGN option, TYPE=GWNAU, or TYPE=GWNAUD.

Use the NETWORK option with the SUBAREA and TGN options to analyze a transmission group. If you specify the TGN option and do not specify the NETWORK option, the native network is the default.

NCP V7R1: Use the NETWORK option with TYPE=NETPOOL to analyze network control blocks for a particular network. If you specify TYPE=NETPOOL and do not specify the NETWORK option, the default includes data from all networks.

RESET Option

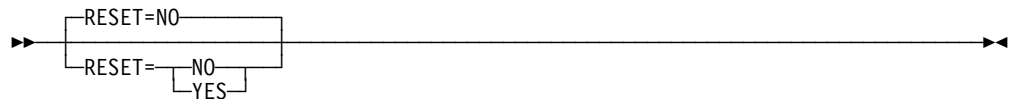

This option specifies when NTuneMON is to use the NetView global variables from the previous NTuneMON execution or reset the NetView global variables. This information includes NCP addresses and thresholds you enter in NTuneMON. The default is RESET=NO. If NTuneMON detects a difference in the generation level in NCP, variables are forced to reset.

This option is ignored if NTuneMON information was not saved at the end of the previous session, that is, if the previous session was started with GLOBAL=NONE.

Attention: When the NetView program is stopped, all global variables are lost. With NetView V2R2 and later releases, you can use the GLOBAL option to save global variables to VSAM to prevent them from being lost.

Starting NTuneMON

NO

Causes NTuneMON to use the information saved as NetView global variables. This can improve NTuneMON performance because NTuneMON does not need to redetermine NCP addresses.

YES

Causes NTuneMON to reset the NetView global variables for the NCPs to be monitored during this session. (The global variables for other NCPs are not affected.) NTuneMON redetermines NCP addresses and resets all thresholds to their default values.

When an NCP is regenerated, NTuneMON normally resets the global variables for that NCP even if you specify RESET=NO. However, if GENLEVEL on the BUILD statement is coded with the same value as the previous time the NCP was generated, NTuneMON does not reset the global variables for that NCP automatically; in this case, specify RESET=YES to reset them.

Note: The GLOBAL and RESET options perform complementary functions in determining whether information from one NTuneMON session is used for the next session. GLOBAL determines whether NTuneMON information is saved at the end of a session, and RESET determines whether saved information is used at the beginning of a session or discarded.

SCOPE Option

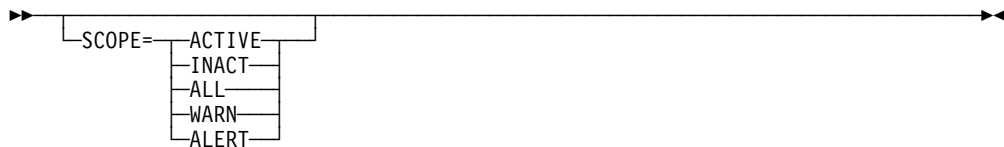

This option specifies which resources NTuneMON is to monitor. Certain SCOPE values are valid only when you specify certain values for the TYPE option. The default is SCOPE=WARN if you specify TYPE=SUMMARY; otherwise, the default is SCOPE=ACTIVE.

ACTIVE

Causes NTuneMON to monitor only active resources.

INACT

Causes NTuneMON to monitor only inactive resources. SCOPE=INACT is valid only when you specify TYPE=CPNAME, IDBLK, LINE, MAC, or TG.

ALL

Causes NTuneMON to monitor all active and inactive resources. SCOPE=ALL is valid only when you specify TYPE=CPNAME, IDBLK, LINE, MAC, or TG.

WARN

Causes NTuneMON to display only warnings and alarms. SCOPE=WARN is valid only when you specify TYPE=TG, VR, or SUMMARY.

ALERT

Causes NTuneMON to display only alarms and to issue generic alerts (if specified). SCOPE=ALERT is valid only when you specify TYPE=TG, VR, or SUMMARY.

Note: SCOPE=ALARM has the same effect as SCOPE=ALERT.

SUBAREA Option

This option specifies the destination subarea address for transmission group analysis. This option is required for transmission group analysis.

Use this option with the NETWORK and TGN options to analyze a transmission group.

TGN Option

This option specifies the transmission group number for transmission group analysis. This option is required for transmission group analysis.

Use this option with the NETWORK and SUBAREA options to analyze a transmission group. When you specify the TGN option, the native network is the default if you do not specify the NETWORK option.

TYPE Option

¹ TYPE option values are shown in Table 2-4 on page 2-22.

Example: TYPE=SUMMARY,BUF,UTILD

This option specifies which types of NCP resources NTuneMON is to analyze. You can specify multiple TYPE values, separated by commas (not blank spaces). Table 2-4 on page 2-22 lists the values you can specify for TYPE and describes the function of each.

How to Read Table 2-4 on page 2-22: The information displayed for most TYPE values is also available on particular NTuneMON panels. Table 2-4 indicates which panel contains the information displayed for each type value.

Note: TYPE option is ignored if OUTPUT=PAGE (if you specify OUTPUT=PAGE all values are displayed).

TYPE is a useful way to send NTuneMON information on certain resources to the NetView screen or log (OUTPUT=LINE or LOG), or to cause NTuneMON to issue alerts only for certain resources (OUTPUT=NONE).

TYPE Option Values: In addition to the TYPE values described in Table 2-4 on page 2-22, you can specify the last two letters of some panel IDs to return data for the resources displayed on that panel. For example, you can specify TYPE=SS to obtain the information displayed on the ATUSS Summary Status panel.

Starting NTuneMON

Table 2-4 (Page 1 of 4). TYPE Option Values

TYPE Value	NTuneMON Panel	Information Given	Comments
ARP	None	In-use counts for Address Resolution Protocol (ARP) table entries for Ethernet-type LAN resources. ARP table entries are defined by ARPTAB on the PU definition statement.	ARP analysis is available only with the TYPE option. For V6R1 or later. Note: This analysis can take a long time to run and can use a large amount of NetView storage and processing time.
BUF BUFPOOL BUFFERS	ATUBP NCP Buffer Pool	Information on the use of NCP buffer pools.	
CBPOOL	ATUCB Control Block Pools/Tables	Information on NCP control block pools and tables.	
CDS	ATUCD CDS NCP Selection	General NCP information, including subarea address, usage tier, controller model and serial number, memory size, CCU operating mode, and MOSS EC and FIX levels.	Although you can specify the names of particular NCPs to be analyzed, this value is intended for use in displaying all active NCPs.
CPNAME IDBLK LINE MAC SUB	ATUTA Token-Ring SNA Station List	The following information for all stations connected through one or all Token-Ring interface couplers (TICs): CPNAME PU T2.1 node names IDBLK IDBLK-IDNUM LINE Logical line name MAC Medium access control address SUB Subarea and transmission group numbers You can specify one or two of these values. The information is sorted by the first value you specify.	Specify the ADDR option to display a particular line, or omit the ADDR option to display all lines. You can also specify SCOPE=ACTIVE, INACT, or ALL.
CSS ESCON	ATUCS 3746-900 Logical Lines	Information on the ESCON logical lines and stations associated with an ESCON physical link, including address, status, pacing window sizes, and subarea and transmission group numbers.	IBM 3745 with 3746 Model 900 only. Specify the ADDR option to identify the physical line. If you specify an ESCON line address, the default is TYPE=CSS.
DLCI FHSP TESP	ATUFA Frame Relay Support List	The following data link connection identifiers (DLCIs) for a single frame-relay physical line: Peripheral TESP Subarea TESP FHSPs	NCP V6R2 or later. Specify the ADDR option to identify the physical line.
ET	ATUET Ethernet Adapter Sta- tistics	Information on an Ethernet-type LAN line.	For IBM 3745 with ESS adapter. Specify the ADDR option to identify a particular line.
ETHER	ATUEP Ethernet Adapter List	Information on all Ethernet-type LAN physical lines, including traffic rates.	For IBM 3745 with ESS adapter.

Table 2-4 (Page 2 of 4). TYPE Option Values

TYPE Value	NTuneMON Panel	Information Given	Comments
FC FR	ATUFC Physical Line List	The status of all frame-relay physical lines defined to an NCP.	NCP V6R2 or later. If TYPE=FP and TYPE=FR FC are specified together, TYPE=FR FC must be specified first.
FP	ATUFP Frame Relay Physical Line Details Page 1	Information on a frame-relay physical line.	NCP V6R2 or later. Specify the ADDR option to identify the physical line. If TYPE=FP and TYPE=FR FC are specified together, TYPE=FR FC must be specified first.
GEN	ATUNP NCP Selection	General NCP information, including subarea address, generation date, NCP and SSP releases, the operating system under which NCP was generated, and controller model and serial number.	Although you can specify the names of particular NCPs to be analyzed, this value is intended for use in displaying all active NCPs.
GWNAU	ATUNA GWNAU Names and HSCBs	GWNAU in-use counts for one or all networks.	Use the NETWORK option to specify a specific network; otherwise, all networks are included. NCP Releases before NCP V6R2: This analysis can take a long time to run and can use a large amount of NetView storage and processing time.
GWNAUD	ATUIB GWNAUs in Use Counts	GWNAU in-use counts for one or all networks, along with the name of each GWNAU and the number of HSCBs in use by each GWNAU. In NCP V7R1, this panel is displayed as ATUIC.	Use the NETWORK option to specify a specific network; otherwise, all networks are included. NCP Releases before NCP V6R2: This analysis can take a long time to run and can use a large amount of NetView storage and processing time.
HSCB	ATUNN HSCBs (Net- works and HSCB Counts)	HSCB in-use counts for each network.	NCP V6R2 and later releases: Also displays GWNAU in-use counts.
IP	ATUIS IP Router Sta- tistics Page 1	Internet Protocol (IP) router statistics.	NCP V6R2 or later. IP information is displayed only if the NCP is connected to an Ethernet-type LAN.
IPSP	ATUFA Frame Relay Support List	IP-support (IPSP) DLCIs for a frame-relay line.	NCP V7R3 or later. Specify the ADDR option to identify the physical line.
MLTG	ATUML Multi-Link Trans- mission Group	Information on a single-link or multilink transmission group and the NCP at the origin end of the transmission group.	Also specify the SUBAREA and TGN options. If you specify TGN, NTuneMON uses TYPE=MLTG by default.
NETPOOL	ATUGP Network CB Pools/Tables	Information on control blocks defined on a per-network basis.	The default is to include data for all networks. Use the NETWORK option to specify a particular network.

Starting NTuneMON

Table 2-4 (Page 3 of 4). TYPE Option Values

TYPE Value	NTuneMON Panel	Information Given	Comments
NNT	ATUNT NCP Network Names Table	Each entry in the network names table, including all CPNAMEs and NETIDs and the number of sessions for each.	NCP V7R1 and later entries that are created dynamically using DYNPOOL are not displayed.
NW	ATUNW NCP Wide Selection	General NCP information, including number of networks, and use of CCU cycles, buffers, and control block pools.	Although you can specify the names of particular NCPs to be analyzed, this value is intended for use in displaying all active NCPs. Note: If you specify TYPE=NW on a screen 80 characters wide, the information will wrap.
PL	ATUPL SDLC Physical Line Details	Information on a single SDLC physical line.	Specify the ADDR option to identify the physical line.
SCANNERS ADAPTERS	ATUSC1 Channel Adapters, ATUSC2 Line Adapters Page 1, and ATUSC4 3746 Model 900 Adapters	Information on channel, line, and CSS adapters.	IBM 3745 only.
SL	ATUSL SDLC Stations List	Information on the stations associated with a single SDLC physical line.	Specify the ADDR option to identify the SDLC physical line.
SLOWDOWN	ATUBS Buffer Slowdown Information Page 1 ATUBX Buffer Slowdown Information Page 2	FFDC information captured when NCP enters slowdown.	TYPE=SLOWDOWN is available for all Version 7 NCPs that have the ability to capture the slowdown information.
SUMMARY	ATUSS Summary Status	A variety of information for each NCP.	Performs the same analysis as TYPE=CDS,GEN,BUF,TG,VR and SCOPE=WARN.
TG	ATUTG Transmission Group	Information on transmission groups for one or all active NCPs.	Can be used with all SCOPE option values.

Table 2-4 (Page 4 of 4). TYPE Option Values

TYPE Value	NTuneMON Panel	Information Given	Comments
TP	ATUTP1 Token-Ring TIC Details Page 1	Information on a single Token-Ring physical line, including MAC address, TIC type, Token-Ring speed, status, maximum transmit and receive frame sizes, logical lines in-use counts, congestion count, port address, last beaconing MAC address, and nearest active upstream neighbor.	NCP V5R4 or later. Use the ADDR option to specify a particular Token-Ring line. TYPE=TP is the default if you specify ADDR for a Token-Ring line and do not specify TYPE.
TR	ATUTC Token-Ring Adapter List	Information on all Token-Ring physical lines, including logical line in-use counts, MAC address, TIC type, Token-Ring speed, status, and maximum transmit and receive frame sizes.	NCP V5R4 or later.
UTIL UTILD	ATUUT NCP Utilization	Information on CCU and buffer use, including a histogram showing the percentage of time at each use level.	
VR	ATUVR Virtual Route	Information on virtual routes.	Can be used with all SCOPE option values.

Solving NTuneMON Problems

This section describes how to solve various problems you might encounter while using NTuneMON. If the solution described here does not solve the problem you encountered, or if you encounter a problem that is not described here, contact your IBM Service Representative.

NTuneMON or Panels Are Not Found

If the NTuneMON program or panels are not found, the ATUNEMON CLIST library or panel library might not be installed. See "Installing NTuneMON" on page 2-8 for more information.

NTuneMON Cannot Find a Particular NCP

If NTuneMON cannot find a particular NCP, follow these steps:

1. Verify that the NCP is in the native network and has been activated by the VTAM host on which NTuneMON is running.
2. Verify that the NCP is V4, V5, V6, or V7.
3. Verify that the NCP responds to the VTAM command
D NET,NCPSTOR,ID=*ncpname*,ADDR=0.
4. If you started NTuneMON with OUTPUT=LINE or OUTPUT=LOG, verify that messages are not suppressed by NetView automation.
5. If you receive an error response, verify that STORDSP is coded as a value for OPTIONS on the NCP SYSCNTRL statement.
6. If you receive message ATUM103, see the user response to message ATUM103 on page 9-4. In addition, check the VTAM startup option parameter

Solving NTuneMON Problems

DSPLYDEF. If you let DSDPLYDEF default to 100, then when a Display Majnodes command is issued, the maximum display is 100 resources. To ensure that NCPs are detected, code DSDPLYDEF large enough to include NCPs in the Display Majnodes command.

7. If the preceding steps do not solve the problem, restart NTuneMON with FAST=NO and RESET=YES. You can also specify DEBUG=YES or DEBUG=LOG to view the interaction between NTuneMON and the NCPs.

Note: If you are reloading an NCP using the same NEWNAME as defined on the existing BUILD definition statement; go back and press F12 on the ATUNP NCP Selection panel as shown on page 4-204, to *REFRESH* the information regarding the changed NCPs.

NTuneMON Produces Unexpected Output

If NTuneMON produces NCP information that is greatly different from what you expected, restart NTuneMON with RESET=YES. You can also specify DEBUG=YES or DEBUG=LOG to view the interaction between NTuneMON and the NCPs.

If you are running a compiled copy of NTuneMON, please do the following to determine whether the problem is in NTuneMON or REXX. Attempt to reproduce the failure using the interpreted CLIST of NTuneMON. If the failure repeats, then NTuneMON has a problem. If the interpreted CLIST works, then the REXX compiler may have a problem. Now compile NTuneMON with the OPTIMIZE option set to NO. If this copy of the compiled NTuneMON functions correctly, then the REXX OPTIMIZE function has a problem; if it fails, then the REXX compiler has a problem.

NTuneMON Startup Is Slow

When you start NTuneMON, it might take a long time to display the first panel if there are many active NCPs. To reduce startup time, try either of the following:

- Monitor only certain NCPs instead of all NCPs. For more information, see “Specifying NCPs to Monitor” on page 2-12.
- Use the FAST startup option to prevent NTuneMON from identifying all active NCPs. For more information, see “FAST Option” on page 2-17.

NTuneMON Failure at Startup

If NTuneMON fails at startup, for example the program gets unexpected errors, it is possible that one of the global variables saved in NetView has been destroyed or changed. When this happens, it is possible that NTuneMON has unrecoverable errors.

1. Restart NTuneMON with the RESET=YES option.
2. If that restart fails, restart NTuneMON again with the following options: RESET=YES, FAST=NO, and DEBUG=YES.
3. If that restart fails, retain the output and contact IBM support.

NTuneMON Takes a Long Time to Display Information

NTuneMON analysis of GWNAUs, ARP resources, or Token-Ring stations might take a long time. Enter the CANCEL command on the NetView command line if you do not want to wait for the analysis. See “Using NTuneMON with Fast-Path Commands” on page 3-4.

NTuneMON Runs Short of NetView Storage

NTuneMON analysis of GWNAUs, ARP resources, or Token-Ring stations might require a large amount of NetView storage. To cause the NetView program to automatically free storage used by NTuneMON, follow these steps:

1. Enter the NetView DEFAULTS REXXSLMT command on the NTuneMON or NetView command line. This command causes the NetView program to release storage used by a REXX CLIST when the CLIST ends. You can enter this command at any time during a NetView session. See “Using NTuneMON with Fast-Path Commands” on page 3-4.
2. Exit NTuneMON to release the storage used for that session.
3. Restart NTuneMON.

NTuneMON Times Out

If NTuneMON times out, verify that:

- There is only one NTuneMON running on your NetView operator ID. Press the ROLL PF key until you return to the NetView panel.
- All NCPs respond to the VTAM command `D NET,NCPSTOR,ID=ncpame`.
- NetView messages are not suppressed by NetView automation.
- The NCP is not in the slowdown state.

When you have verified these items, restart NTuneMON with `RESET=YES` to reset NetView global variables. You can also specify `DEBUG=YES` or `DEBUG=LOG` to view the interaction between NTuneMON and the NCPs.

NTuneMON Does Not Issue Generic Alerts

Verify that YES is specified on the GENALERT option for the startup command. If GENALERT=NO is specified, you can type GENALERT or ALERT on the command line of any panel to activate the generic alert process.

Notes:

1. You can start or stop generic alerts using the startup command or by typing ALERT or GENALERT from the command line.
2. NTuneMON issues the alert only if the alert condition exists at the time you display the panel or when you press the REFRESH PF key.
3. When running in line, log, or none modes, the alerts are issued only during the snapshot of the run.

If problems persist, verify that generic alerts are not being filtered out by the NetView program or suppressed by NetView automation. Refer to *TME 10 NetView for OS/390 User's Guide* for more information.

NTuneMON Does Not Analyze Transmission Groups

NTuneMON does not analyze transmission groups on the ATUSS Summary Status panel when the number of transmission groups defined (MAX) is equal to or greater than the STOP count value. To analyze a larger number of transmission groups, increase the STOP value or use the ATUTG Transmission Group panel.

Note: Processing time depends on the number of transmission groups you specify. For a large number, processing will take longer.

Chapter 3. Using NTuneMON

Using NTuneMON with PF Keys	3-3
Regular PF Keys	3-3
Special PF Keys	3-4
Using NTuneMON with Fast-Path Commands	3-4
Using Fast-Path Commands with Secondary Panels	3-5
Entering Fast-Path Commands and NCP Names	3-6
Using NetView Commands with NTuneMON	3-6
Working with NTuneMON Panels	3-6
Entering Values in Panel Fields	3-7
Example of Information to be Displayed on the Current Panel	3-7
Example of Information to be Displayed on Another Panel	3-8
Example of Thresholds for Resource Use	3-8
Not Applicable Versus Not Available	3-9
Saving the Values You Enter	3-9
How Color Is Used on NTuneMON Panels	3-10
Refreshing Panel Data	3-10
Saving NTuneMON Data to the NetView Network Log	3-11

This chapter describes how to use NTuneMON interactively through NTuneMON panels and includes the following topics:

- Using NTuneMON with PF keys
- Using NTuneMON with fast-path commands
- Using NetView commands with NTuneMON
- Working with NTuneMON panels

To use NTuneMON interactively, omit the OUTPUT option or specify OUTPUT=ANEL when you start NTuneMON.

For detailed information on a particular NTuneMON panel, refer to Chapter 4, “Using NTuneMON Panels for Monitoring” on page 4-1.

Using NTuneMON with PF Keys

There are two types of programmed function keys (PF) keys for NTuneMON: regular keys that appear on all NTuneMON panels, and special keys that appear only on certain NTuneMON panels. For more detailed information about a particular PF key as it is used on an NTuneMON panel, locate the panel in Chapter 4, “Using NTuneMON Panels for Monitoring” on page 4-1.

Regular PF Keys

F1=HELP

Displays online help for this panel.

F3=RETURN

Returns to the NTuneMON panel from which the first display of the multi-view panel was invoked. For example, pressing F3 from ATUSP2, returns to the NTuneMON panel from which ATUSP1 was invoked.

F6=ROLL

Returns to the NetView command line without exiting NTuneMON. To return to NTuneMON from the NetView program, press F6=ROLL or enter **ATUNEMON** on the NetView command line.

F10=HEX

Displays the ATUDP Hexadecimal Storage Display panel, as shown on page 4-68. On many NTuneMON panels, you can select an item such as an NCP, a virtual route, a line, or a physical unit and press F10=HEX to see the hexadecimal display of the control block associated with that item.

For more information about what control block is displayed when pressing F10=HEX from a specific NTuneMON panel, locate the panel in Chapter 4, “Using NTuneMON Panels for Monitoring” on page 4-1.

F12=REFRESH

Updates the panel status.

PA1=EXIT

Exits NTuneMON.

PA2=LOG

Saves the information on that panel to the NetView log.

Special PF Keys

For more detailed information about a particular PF key as it is used on an NTuneMON panel, locate the panel in Chapter 4, “Using NTuneMON Panels for Monitoring” on page 4-1.

Note: These special PF keys are not available on all panels. These keys are used only on selected panels.

F5=MODIFY

Updates NCP tuning parameters with the modified values.

Note: F5=MODIFY is not displayed if the operator does not have tuning authority or if NTuneNCP is not included in the gen. For information about how to use F5=MODIFY, see “Implementing Tuning Changes” on page 5-15.

F11=ALT-PFKS

Resets some of the PF keys on a panel to perform different functions. An example of an NTuneMON panel with the F11=ALT-PFKS function is the ATUNP NCP Selection panel, as shown on page 4-204.

ENTER

Specific use of this key depends on the panel that is displayed.

Using NTuneMON with Fast-Path Commands

Many panels can be displayed using a fast-path command. You can enter a fast-path command on the NTuneMON command line (except on help panels) to display one of these panels. Table 3-1 lists all NTuneMON panels that have basic fast-path commands. Basic means that you need the appropriate version and release of NCP and the appropriate resource to use the basic fast-path commands. Valid basic fast-path commands are shown in the table next to each panel. You can also refer to Chapter 4 to locate a fast-path command for any NTuneMON panel.

Table 3-1 (Page 1 of 2). NTuneMON Panels with Fast-Path Commands

NTuneMON Panel	Fast-Path Commands
ATUBP NCP Buffer Pool	BP, BUF, BUFFERS, BUFPOOL
ATUBS Buffer Slowdown Information Page 1	BS, SLOWDOWN
ATUBX Buffer Slowdown Information Page 2	BX
ATUCB Control Block Pools/Tables	CB, CBPOOL
ATUCD CDS NCP Selection	CD, CDS
ATUDL ISDN Physical Line Table	DL, ISDN
ATUDP Hexadecimal Storage Display	DP, HEX
ATUEP Ethernet Adapter List	EP, ETHER, ETHERNET
ATUET Ethernet Adapter Statistics	ET
ATUFC Physical Line List	BISYNC, BSC, FC, FR, FRELAY, FRAMERELAY, SDLC
ATUHP HPR & Other Global Flow Control Parms	HP, HPR
ATUIB GWNAUs in Use Counts	IB, NAUD, GWNAUD
ATUIC Non-Dynamic GWNAUs in Use Counts	IC, NAUD, GWNAUD
ATUIL IP Interface Information	IL, IPLIST
ATUIS IP Router Statistics Page 1	IS, IP, IPSTAT, IS1

Table 3-1 (Page 2 of 2). NTuneMON Panels with Fast-Path Commands

NTuneMON Panel	Fast-Path Commands
ATUNA GWNAU Names and HSCBs	NA, NAUS, GWNAU, GWNAUS
ATUNG HSCBs and GWNAUs	NG, NAUS, GWNAU, GWNAUS
ATUNI NTuneNCP Information	NI, NTTCB
ATUNN HSCBs (Networks and HSCB Counts)	NN, HSCB, HSCBS
ATUNP NCP Selection	NP, GEN
ATUNT NCP Network Names Table	NT, NNT
ATUNW NCP Wide Selection	NW
ATUPL SDLC Physical Line Details	PL (see page 4-217)
ATUSC1 Channel Adapters	SC, SC1, SCANNER, SCANNERS, ADAPTER, ADAPTERS
ATUSC2 Line Adapters Page 1	SC2
ATUSC3 Line Adapters Page 2	SC3
ATUSC4 3746 Model 900 Adapters	SC4, 3746900, 3746, CSS, ODLC
ATUSS Summary Status	SS, SUM, SUMMARY
ATUST NCP Function Activation	ST, SNAP, SNAPTRACE, POLL
ATUTC Token-Ring Adapter List	TC, TR, TIC, TOKENRING, NTRI
ATUTG Transmission Group	TG, TGS
ATUUT NCP Utilization	UT, UTIL, UTILD
ATUVR Virtual Route	VR, VRS, VRB
ATUXL X.25 MCH Physical Line List	NPSI, MCH, X25, X25NPSI, NPSIX25

Note: NTuneMON ignores all characters following the cursor on the command line, so when you type a command over a message displayed on the command line, you do not need to clear the remaining characters.

If you enter a fast-path command that is not valid, press the ROLL PF (F6) key or enter **ATUNEMON** on the NetView command line to return to the NTuneMON panel.

You can also display a panel by entering one of the values of the TYPE startup option.

Using Fast-Path Commands with Secondary Panels

For those panels that display particular resources, you can use the fast-path command only if the panel and resource were displayed previously. To display one of these “secondary” panels for the first time or for a different resource, you need to use the PF keys provided in other panels.

Entering Fast-Path Commands and NCP Names

Many panels, such as the ATUTG Transmission Group panel, as shown on page 4-294, display all of a certain type of resource for a particular NCP. You can specify the NCP as an argument of the fast-path command for any of these panels. For example, to view the transmission groups for NCP40, enter:

```
TG NCP40
```

In any of these panels, you can also type a new NCP name over the NCP name displayed on the top line of the panel and refresh the panel to display the same resources for a different NCP.

In an NCP selection panel (ATUNP NCP Selection, ATUCD CDS NCP Selection, or ATUNW NCP Wide Selection), you do not need to type the NCP name following the fast-path command. Instead, you can type the fast-path command on the command line, place the cursor under an NCP name, and press Enter.

Using NetView Commands with NTuneMON

You can enter NetView commands on the command line of an NTuneMON panel. NTuneMON passes any command that it does not recognize to the NetView program. When you enter a NetView command, NTuneMON returns you to the NetView command line without exiting NTuneMON. To return to NTuneMON from the NetView program, press the ROLL PF (F6) key or enter **ATUNEMON** on the NetView command line.

Working with NTuneMON Panels

Figure 3-1 on page 3-7 shows a sample NTuneMON panel. The top line of each panel shows general information about NTuneMON and the panel. The panel ID (ATUxxx) appears in the upper left corner, followed by the NCP name (in NCP-specific panels), the panel name, NTuneMON version and release (V2Rx), and the current system time in 24-hour format. The remainder of the panel presents NCP information.

```

ATUTC  A71TEST      Token-Ring Adapter List      NTuneMON V2R4  14:16
Total Logical Lines Active= 9      Total Defined= 213  User Alarm= 80
PORT LINE      MAC      LOGICAL LINES
ADD  ADDR      ADDRESS      ACTIVE  TOTAL  T/R  MXTSL  RCVBF  TYPE  TIC  STATUS
-----|-----|-----|-----|-----|-----|-----|-----|-----|-----|-----|
ANY  -          -          - 0    100   -    -      -     -    -    -
88   1088      400000711088 100% 5    5    16M  4096  8192  ANY  TIC2  INACTIVE
89   1089      400000711089 100% 4    4    16M  4096  8192  ANY  TIC2  INACTIVE
ANY  -          -          - 0    100   -    -      -     -    -    -
76   2144      400000712144 0% 0    4    16M  4096  -     ANY  TIC3  INACTIVE
-    -          -          - -    -    -    -      -     -    -    -
-    -          -          - -    -    -    -      -     -    -    -
-    -          -          - -    -    -    -      -     -    -    -
-    -          -          - -    -    -    -      -     -    -    -
-    -          -          - -    -    -    -      -     -    -    -

| FOR DIRECT FIND ENTER ONE: | STATUS DEFAULT | VIEW DEFAULT |
| XID IDBLK-IDNUM= _____| ACTIVE INACTIVE| MAC SUB CPNAME|
| T/R MAC ADDRESS= _____| ALL (ACT/INACT)| IDBLK LINE   |
| PU-T2.1 CPNAME = _____|                 | (DUAL)       |
| NCP LINE NAME = _____| STATUS= ACTIVE | MAC          |
-----|-----|-----|
=>
F1=HELP F2=SUBAREA F3=RETURN 4=BNN IDBLK-IDNUM F5=MAC ADDR F6=ROLL F7=BACK
ENTER=PHYSICAL TIC F8=FWD F9=ALL TICS F10=HEX F11=FUNC F12=REFRESH PA2=LOG
    
```

Figure 3-1. Sample NTuneMON Panel

Note Regarding the NTuneMON Version and Release Identifier: Although the sample panels in this book display various NTuneMON release numbers, your actual NTuneMON panels will display your current NTuneMON release number.

Entering Values in Panel Fields

You can enter values in certain fields on many panels. You can use the Tab key to move between input fields. Input fields can specify any of the following types of information:

- Information to be displayed on the current panel
- Information to be displayed on another panel
- Thresholds for resource use to control the generation of warnings and alerts.

Example of Information to be Displayed on the Current Panel

Figure 3-2 on page 3-8 shows a sample NTuneMON panel with input fields that specify information to be displayed on that panel. The input fields are DEFAULT VIEW, DUAL, STATUS, TIC, and FIND. You can enter a new value in any of these fields to change the information on this panel. For information on how color is used on NTuneMON panels, see “How Color Is Used on NTuneMON Panels” on page 3-10.

```
ATUTA A71NT05 Token-Ring SNA Station List 1 NTuneMON V2R1 11:36
DEFAULT VIEW= MAC DUAL= STATUS= ACTIVE TIC= ALL FIND=
MAC Address DSAP MAC Address DSAP MAC Address DSAP
400000041093 04

=>
F1=HELP F2=SUBAREA 3=RETURN F4=BNN IDBLK-IDNUM F5=MAC ADDR F6=ROLL F7=BACK
ENTER=STATION DETAILS F8=FWD F9=ALL TICs F10=HEX F12=REFRESH PA1=EXIT PA2=LOG
```

Figure 3-2. Example of Information to be Displayed on the Current Panel

Example of Information to be Displayed on Another Panel

Figure 3-1 on page 3-7 shows a sample NTuneMON panel with underlined input fields that specify information to be displayed on another panel. In this example, the input fields are located in a box on the lower part of the screen. You can enter a new value in any of these fields to change the information on a different panel. For more information on how color is used on NTuneMON panels, see “How Color Is Used on NTuneMON Panels” on page 3-10.

Example of Thresholds for Resource Use

Figure 3-3 on page 3-9 shows a sample NTuneMON panel with input fields that specify thresholds for resource use to control the generation of warnings and alerts. In this example, the input fields are USER ALARM, ALARM, and STOP. You can enter a new value in any of these fields to change the threshold information. Threshold input fields are shown on NTuneMON panels in underscore pink. For more information on how color is used on NTuneMON panels, see “How Color Is Used on NTuneMON Panels” on page 3-10.

Note: You can enter a threshold value greater than 100% to prevent NTuneMON from generating an alert when a particular resource is at maximum use.

```

ATUSS A27GENC Summary Status CCU= 0% Storage= 2% NTuneMON V2R6 14:33
-----
GENERATION INFORMATION          3745 HARDWARE INFO          SNI INFORMATION
03/22/1999 17:38:22           MICROCODE EC = D39894A       SNI NETWORKS= 1
3745-41A 8MB A27GENC          FIX = M894A055             HSCBS IN USE= 0      0%
SA 27 S/N= 0003606           CDS Update= 03/11/1999     NATIVE NETID= NETA
ACF SSP V4R8 MVS                                     BUFFER POOL INFORMATION
ACF NCP V7R8F CCU B          3746 M900 INFORMATION      BUFFERS 1%
564806300 TWIN-DUAL          S/N= 0090292              BPOOL 0%
USAGE TIER = 5/A              DYNPOOL 0%
LOADED OVER CHANNEL
-----
VR INFORMATION                  VRTP NETWORK SUBAREA CUR MAX MIN RCVDQ XMTQ VR STATE
ACTIVE/MAX= 2/33              0.0 NETA 1 45 45 15 0 0
ALARM/WARN= 0/1
USER ALARM= 100%
-----
TG INFORMATION                  TGN NETWORK SUBAREA LOW MEDIUM HIGH TOTAL
ACTIVE/MAX= 1/2              1 NETA 1 384 - - 384
ALARM/WARN= 0/1
ALARM= 100% STOP= 40
=>
PF1=HELP 2=VRs 3=RETURN 4=SNI(HSCBS) 5=ADAPTERS 6=ROLL 8=CBPOOLS 9=NNTs
ENTER=REFRESH 10=UTIL 11=ALT-PFKS 12=REFRESH SUMMARY PA1=EXIT PA2=LOG

```

Figure 3-3. Example of Thresholds for Resource Use

Not Applicable Versus Not Available

When N/A is displayed for a particular field, the field is not applicable for the displayed resource. For example, on the ATUSD SDLC Station Details panel, as shown on page 4-241, the #PIUs/BLOCK field applies only to subarea stations. If the panel is being displayed for a peripheral station, the #PIUs/BLOCK field contains N/A.

When a dash (–) is displayed for a particular field, the field applies, but the data is not available for displaying. For example, NCP began collecting polling statistics for NCP V7R2. If the ATUCH Channel Adapter Details panel, as shown on page 4-32, is being displayed for NCP V7R1 or earlier releases, a – is displayed in the fields. For NCP V7R2 or later releases, polling statistics are displayed in the polling fields.

Note: This is the convention. However, there may be cases where NTuneMON uses N/A and (–) interchangeably.

Saving the Values You Enter

The values you enter in input fields can be saved as NetView global variables. When you do this, the values you enter during one NTuneMON session are preserved for your next session. For more information, see “GLOBAL Option” on page 2-18 and “RESET Option” on page 2-19.

How Color Is Used on NTuneMON Panels

NTuneMON highlights certain panel fields in color or reverse video to draw your attention to important information.

Underscore Pink

Indicates an input field for thresholds that can be changed.

Reverse-Video Pink

Indicates warning conditions such as either a possible problem or a tuning field that was entered in error. See “Implementing Tuning Changes” on page 5-15 for information about how to modify tuning fields.

Underscore Yellow or reverse-video yellow

May indicate an input field that can be changed.

Red

Indicates that this field contains error information.

Underscore Red

Indicates that this field contains a more severe error than those errors entered in red.

Reverse-Video Red

Indicates that this field contains a potentially critical error. Potentially critical errors include thresholds that are exceeding their values, or based on values set, are causing NTuneMON performance problems.

Underscore White

Indicates a tuning field that cannot be modified until the resource is in the appropriate state. See “Implementing Tuning Changes” on page 5-15 for information about how to modify tuning fields.

Reverse-Video Turquoise

Indicates a tuning field that can be modified. See “Implementing Tuning Changes” on page 5-15 for information about how to modify tuning fields.

NTuneMON highlights fields on specific panels to help you distinguish between various types of information. For example:

- On the ATUTA Token-Ring SNA Station List panel as shown on page 4-273, active stations are shown in yellow, and inactive stations are shown in turquoise.
- On the ATUML Multi-Link Transmission Group panel as shown on page 4-184, active lines that are ready to send data are shown in reverse-video green, while active lines that are not available are shown in reverse-video yellow.

The panel descriptions in Chapter 4 describe the highlighted fields on each panel.

Refreshing Panel Data

The data on each NTuneMON panel is refreshed with current values from NCP storage each time you display the panel. In addition, you can refresh the data on any panel by pressing F12; this is an easy way to monitor various NCP activities.

Saving NTuneMON Data to the NetView Network Log

You can write the data on the current panel to the NetView network log by pressing PA2. All the data on the current panel is written to the log even if there is more than one screen of data. This is an easier way to save NTuneMON data than doing a screen capture for each screen of data. To browse the active network log, enter the command BR NETLOGA on the NTuneMON or NetView command line. See the *TME 10 NetView for OS/390 User's Guide* for details.

Chapter 4. Using NTuneMON Panels for Monitoring

About Tuning Fields	4-3
ATUBP NCP Buffer Pool Panel	4-4
ATUBS Buffer Slowdown Information Page 1 Panel	4-10
ATUBX Buffer Slowdown Information Page 2 Panel	4-14
ATUCB Control Block Pools/Tables Panel	4-17
ATUCD CDS NCP Selection Panel	4-27
ATUCH Channel Adapter Details Panel	4-32
ATUCI Channel IP Statistics Panel	4-36
ATUCL 3746-900 Station Details Panel	4-39
ATUCS 3746-900 Logical Lines Panel	4-43
ATUCX Control Block Pools Extension Panel	4-47
ATUDK ISDN Physical Line Details Panel	4-49
ATUDK2 ISDN Physical Line Details Page 2 Panel	4-55
ATUDL ISDN Physical Line Table Panel	4-59
ATUDM ISDN B-Channel Line Table Panel	4-62
ATUDN ISDN B-Channel Line Details Panel	4-65
ATUDP Hexadecimal Storage Display Panel	4-68
ATUDS ISDN Stations Table List Panel	4-71
ATUDT ISDN Station Details Panel	4-73
ATUED PEP Line Details Panel	4-78
ATUEP Ethernet Adapter List Panel	4-81
ATUET Ethernet Adapter Statistics Panel	4-84
ATUFA Frame Relay Subport List Panel	4-88
ATUFB Frame Relay DLCI CIR Parameters Panel	4-92
ATUFC Physical Line List Panel	4-94
ATUFD Frame Relay DLCI to Balance Table Panel	4-99
ATUFI Frame-Relay IP Link Statistics Panel	4-102
ATUFL Frame Relay Multi Station List Panel	4-105
ATUFP Frame Relay Physical Line Details Page 1 Panel	4-108
ATUFP2 Frame Relay Details Page 2 Panel	4-117
ATUFP3 Frame Relay Details Page 3 Panel	4-122
ATUFS1 Frame Relay Switching Equipment Page 1 Panel	4-127
ATUFS2 Frame Relay Switching Equipment Page 2 Panel	4-131
ATUFT1 Frame Relay Terminating Equipment Details Page 1 Panel	4-135
ATUFT2 Frame Relay Terminating Equipment Details Page 2 Panel	4-143
ATUGP Network CB Pools/Tables Panel	4-149
ATUHP HPR & Other Global Flow Control Parm Panel	4-153
ATUIA ARP Table Entry Panel	4-155
ATUIB GWNAUs in Use Counts Panel	4-158
ATUIC Non-Dynamic GWNAUs in Use Counts Panel	4-161
ATUID IP Interface Information Detail Panel	4-164
ATUIL IP Interface Information Panel	4-169
ATUIR IP Route Table Entries Panel	4-172
ATUIS IP Router Statistics Page 1 Panel	4-175
ATUIX IP Router Statistics Page 2 Panel	4-180
ATUML Multi-Link Transmission Group Panel	4-184
ATUMT Modify Timer Value Panel	4-189
ATUNA GWNAU Names and HSCBs Panel	4-192
ATUNG HSCBs and GWNAUs Panel	4-195
ATUNI NTuneNCP Information Panel	4-199

ATUNN HSCBs (Networks and HSCB Counts) Panel	4-201
ATUNP NCP Selection Panel	4-204
ATUNT NCP Network Names Table Panel	4-209
ATUNW NCP Wide Selection Panel	4-212
ATUPL SDLC Physical Line Details Panel	4-217
ATUPS Bisync/SS Line Details Panel	4-223
ATUPT Bisync/Start Stop Device List Panel	4-227
ATUSC1 Channel Adapters Panel	4-230
ATUSC2 and ATUSC3 Line Adapters Panels	4-233
ATUSC4 3746 Model 900 Adapters Panel	4-237
ATUSD SDLC Station Details Panel	4-241
ATUSL SDLC Stations List Panel	4-246
ATUSP1 SDLC Peripheral Line Parameters Page 1 Panel	4-249
ATUSP2 SDLC Peripheral Line Parameters Page 2 Panel	4-255
ATUSS Summary Status Panel	4-260
ATUST NCP Function Activation Panel	4-269
ATUTA Token-Ring SNA Station List Panel	4-273
ATUTC Token-Ring Adapter List Panel	4-278
ATUTD NTRI Frame Handlers Logical Line Details Panel	4-285
ATUTF NTRI Frame Handler Logical Lines Panel	4-291
ATUTG Transmission Group Panel	4-294
ATUTI Token-Ring IP Statistics Panel	4-298
ATUTL Token-Ring SNA Station Panel	4-301
ATUTP1 Token-Ring TIC Details Page 1 Panel	4-310
ATUTP2 Token-Ring TIC Details Page 2 Panel	4-319
ATUUH Cycle/Buffer Utilization History Panel	4-325
ATUUT NCP Utilization Panel	4-328
ATUVA Virtual Route Control Block Details Panel	4-331
ATUVR Virtual Route Panel	4-334
ATUVT VR Alert Timer Panel	4-338
ATUXD X.25 Virtual Circuit Details Panel	4-341
ATUXF NPSI Virtual Circuit Statistics Panel	4-346
ATUXH X.25 MCH Physical Line Statistics Panel	4-348
ATUXL X.25 MCH Physical Line List Panel	4-350
ATUXP X.25 MCH Physical Line Details Page 1 Panel	4-353
ATUXP Panel for NPSI	4-353
ATUXP Panel for X.25 ODLC	4-358
ATUXS X.25 MCH Physical Line Details Page 2 Panel	4-362
ATUXV X.25 Virtual Circuit List Panel	4-366
ATUXX X.25 VCCPT Information Panel	4-369

This chapter provides a detailed description of the NTuneMON panels. The description of each panel includes:

- The fast-path command to display the panel
- A list of NTuneNCP fields for tuning
- An illustration of the panel
- A general description of the panel
- A description of each panel field
- A description of the PF keys for the panel

About Tuning Fields

This chapter describes all NTuneMON panels. Some of the fields on these panels are tuning fields. Tuning fields are used to tune your NCPs. Tuning fields for each panel are listed above the sample panel.

Tuning information is covered in Chapter 5, “Using the NTuneNCP Tuning Feature” on page 5-1. How to use NTuneMON panels to tune your NCPs is covered in Chapter 6, “Using NTuneMON Panels for Tuning” on page 6-1.

ATUBP NCP Buffer Pool Panel

Basic fast-path commands: BP, BUF, BUFFERS, BUFPOOL

Tuning fields: IPPOOL TOTAL, DYNPOOL TOTAL, ALERT%, ALERT CNT, TSLOW%, TSLOW CNT, QSZALERT (THRESHLD1, THRESHLD2, ACTION)

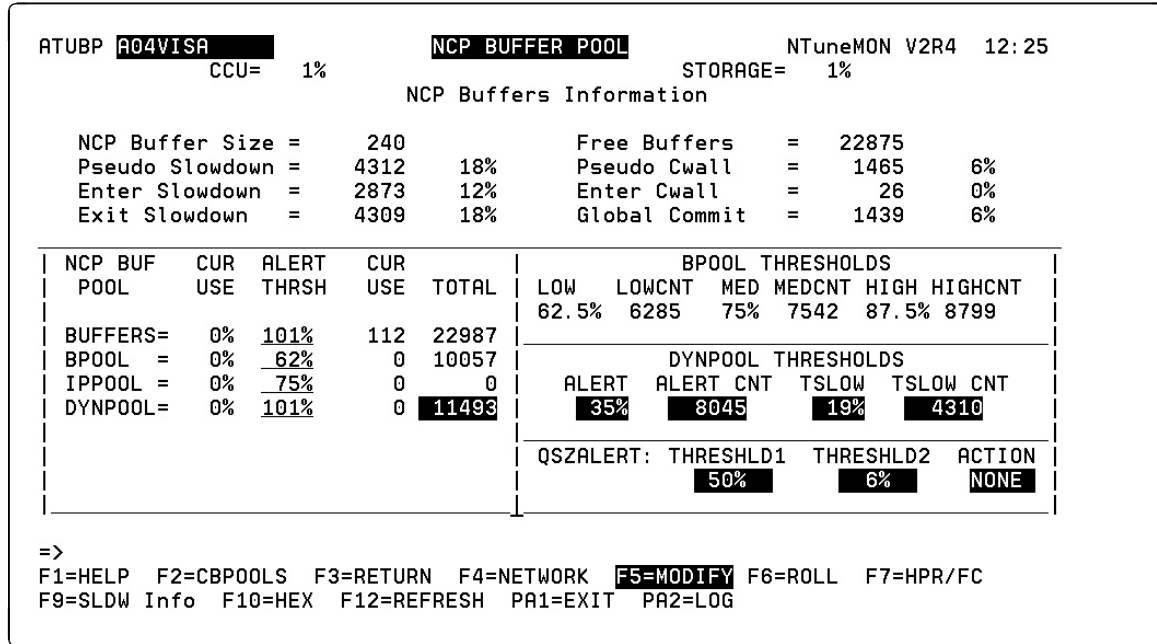

Figure 4-1. ATUBP NCP Buffer Pool Panel

Description

The ATUBP NCP Buffer Pool panel provides information on the use of the NCP buffer pool and its subpools.

To display this panel:

- From the ATUCB Control Block Pools/Tables panel, as shown on page 4-17, press F2.
- From the ATUGP Network CB Pools/Tables panel, as shown on page 4-149, press F4.

Fields

NCP name (second field on panel)

Name of the NCP that is currently displayed. You can enter a different NCP name in this field to display information on another NCP.

CCU

Percentage of controller CCU cycles in use.

STORAGE

Percentage of controller buffer storage in use.

NCP BUFFERS INFORMATION

NTuneMON displays the following information on the use of NCP storage buffers.

Message area

The field above the NCP Buffer Size field may display one of the following messages:

RWI LOW

The reset window indicator (RWI) is on for low-priority sessions.

RWI MEDIUM

The RWI is on for medium-priority sessions.

RWI HIGH

The RWI is on for high-priority sessions.

BPOOL FULL

The destination buffer boundary pool is full; pacing response is withheld.

NCP Buffer Size

NCP buffer size, as defined by the BFRS keyword on the BUILD statement.

Pseudo Slowdown

The point at which NCP enters the pseudo-slowdown state. This occurs when the current number of free buffers plus the global committed buffer count drops below the slowdown entry threshold.

Enter Slowdown

Slowdown threshold, shown as the number of true buffers in use and as the percentage of buffers in use out of the total number defined. This threshold is defined by the SLOWDOWN keyword on the BUILD statement.

When NCP is in the slowdown state, commit requests are not satisfied and are queued on the slowdown chain.

Exit Slowdown

The point at which NCP exits the slowdown state. This occurs when the current number of free buffers rises above the slowdown exit threshold.

When NCP exits the slowdown state, NCP services the requests queued on the slowdown chain.

Free Buffers

Number of buffers currently available.

Pseudo Cwall

The point at which NCP enters the pseudo-CWALL state, as defined by the CWALL keyword on the BUILD statement.

Enter Cwall

The point at which NCP enters the CWALL state. This occurs when the current number of free buffers minus the global committed buffer count drops below the CWALL threshold. When NCP enters the CWALL state, NCP handles only high-priority PIUs. If NCP enters the CWALL state during communication link service, NCP discards incoming PIUs.

The NCP exits the CWALL state when the current number of free buffers minus the global committed buffer count rises above the CWALL threshold.

Global Commit

Number and percentage of NCP buffers that will remain free for messages.

NCP BUFFER POOL

This section of the panel displays information about the NCP buffer pool including use information in the pools.

NCP BUF POOL

BUFFERS

Number of buffers defined. This number depends on the amount of NCP storage (the MEMSIZE keyword on the BUILD statement), the NCP load module size, and the NCP buffer size (the BFRS keyword on the BUILD statement).

Note: The remaining pools are subpools within the buffer pool. Buffers are not set aside in advance for these pools. They are assigned to a pool while they are being used for the pool.

BPOOL

Destination buffer boundary pool. This pool is used to regulate PIUs sent to the NCP peripheral node. BPOOL is a counter independent from the buffer pool. Each NCP has one BPOOL counter.

The BPOOL counter is initialized to 50% of the number of buffers above the slowdown threshold. This is the maximum number of buffers that can be used at the NCP peripheral node. All buffers above slowdown can be leased. No buffers are allocated to BPOOL. Total for BPOOL is the maximum number of buffers that can be in use by the BPOOL. Figure 4-2 shows an example of boundary pool use.

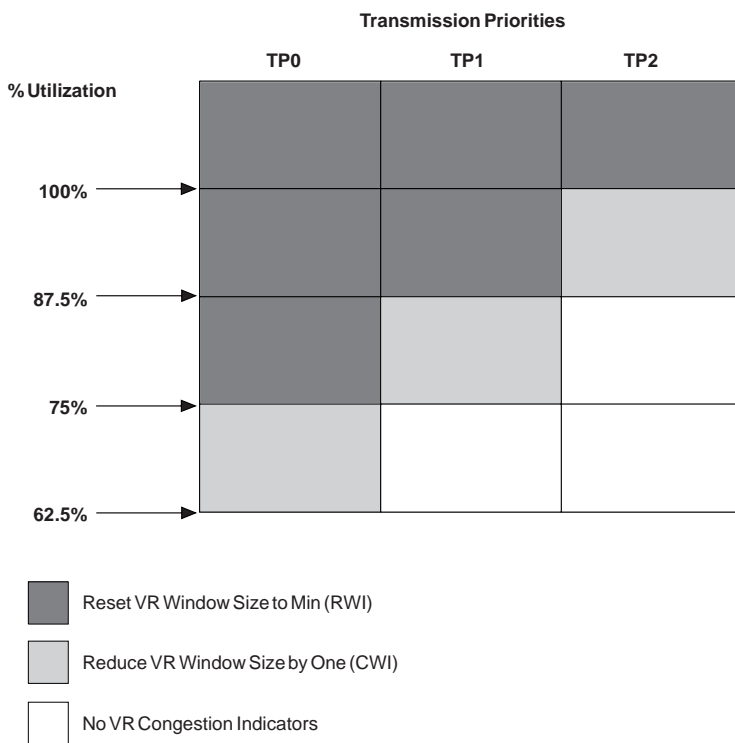

Figure 4-2. Example of Boundary Pool Use

IPPOOL

Number of NCP buffers that can be used to receive IP datagrams from NTRI-attached LAN connections (NCP V7R1), Ethernet-type LAN connections

(starting with NCP V6R1), frame-relay connections (starting with NCP V7R3), or channel connections (starting with NCP V7R3) as defined by the IPPOOL keyword on the BUILD statement.

DYNPOOL (starting with NCP V7R1)

Amount of the buffer pool available for dynamic control block allocation as defined by *percent_of_buffers* suboperand of the DYNPOOL keyword on the BUILD statement.

Use Information

The following use information is shown for each of the buffer pools described previously.

CUR USE (%)

Buffers in use, shown as a percentage of the maximum number of buffers allowed to be used for the pool.

ALERT THRS

Alert threshold for buffer use for each pool. You can enter values in this column to change the alert threshold for each pool.

When the percent of buffers currently in use by the pool reaches this value, the pool name and percentage fields are highlighted in reverse-video red. When the maximum percent in use reaches this value, only the pool name is highlighted.

NTuneMON keeps track of the maximum percent of control blocks in use. When the current maximum percent of control blocks in use exceeds the maximum percent in use NTuneMON has detected so far, it issues a generic alert (if specified). The current maximum percent then becomes the value that determines when the next generic alert is sent.

If the number of buffers needed for IP datagrams exceeds the number of buffers in the pool, the excess frames are discarded before being processed by the Internet router.

CUR USE

Number of buffers in use by the pool.

TOTAL

The total number (rather than a percentage) of buffers that can be used for each pool.

BPOOL THRESHOLDS

NTuneMON displays the following information on buffer pool thresholds:

LOW

If the current number of buffers in use for BPOOL exceeds this percentage, the threshold is highlighted in reverse-video pink.

LOWCNT

If the current number of buffers in use for BPOOL exceeds this count, the threshold is highlighted in reverse-video pink.

MED

If the current number of buffers in use for BPOOL exceeds this percentage, the threshold is highlighted in reverse-video pink.

MEDCNT

If the current number of buffers in use for BPOOL exceeds this count, the threshold is highlighted in reverse-video pink.

HIGH

If the current number of buffers in use for BPOOL exceeds this percentage, the threshold is highlighted in reverse-video pink.

HIGHCNT

If the current number of buffers in use for BPOOL exceeds this count, the threshold is highlighted in reverse-video pink.

DYNPOOL THRESHOLDS (starting with NCP V7R1)

For NCP releases before NCP V7R1 a dash (–) is displayed in these fields.

ALERT (%)

The threshold (number of buffers in use by dynamic control blocks) as a percentage of the buffer pool.

ALERT CNT

The threshold (number of buffers in use for dynamic control blocks) at which NCP is to send an alert (if specified) indicating that the user-defined threshold has been reached, as defined by the *alert_threshold* suboperand of the DYNPOOL keyword on the BUILD statement.

If the current percentage of buffers in use for DYNPOOL exceeds this value, the threshold is highlighted in reverse-video red. NCP sends alerts (if specified) based on this value. This value is the same as ALERT CNT, but is a percentage of the buffer pool.

TSLOW%, TSLOW CNT

The number of free buffers in NCP at which NCP is to fail a request for a dynamically created control block because NCP is getting too close to slowdown.

Note: The Too Close to Slowdown threshold (TSLOW) is *not* a suboperand of an NCP keyword. It is set to a fixed value during NCP initialization.

QSZALERT (starting with NCP V7R6)

This section of the panel displays the buffer-utilization alert parameters as specified on the QSZALERT keyword on the BUILD statement or as tuned on this panel. If the parameters are not set, zeroes are displayed in the THRESHLD fields.

THRESHLD1

The minimum percentage of NCP buffers above the slowdown entry threshold that should be available, as specified by the first suboperand of the QSZALERT keyword. If the amount of buffers available shrinks to this percentage, NCP begins checking for a session or station that is using an excessive amount of buffers.

THRESHLD2

The maximum percentage of NCP buffers above the slowdown entry threshold that should be in use by a single session or station, as specified by the second suboperand of the QSZALERT keyword. If a session or station is found to be using more than the specified amount of buffers, the operator is alerted and, if DEACT is coded on the QSZALERT keyword, the session or station is deactivated.

ACTION

Whether NCP will deactivate (DEACT) a resource that is overusing the buffers or allow it to remain active (NONE), as specified by the third suboperand of the QSZALERT keyword.

PF Keys**F1=HELP**

Displays online help for this panel.

F2=CBPOOLS

Displays the ATUCB Control Block Pools/Tables panel, as shown on page 4-17, to show control block pools usage.

F3=RETURN

Returns to the previous NTuneMON panel.

F4=NETWORK

Displays the ATUNG HSCBs and GWNAUs panel as shown on page 4-195.

F5=MODIFY (if NCP Buffer Size is 128 or greater)

Available when the operator has tuning authority, and NTuneNCP is included. For more information, refer to Chapter 5, Using the NTuneNCP Tuning Feature.

Updates the NCP tuning parameter with the modified value. If the modification is not valid, the field turns reverse-video pink, and you are prompted to correct the value and resubmit it.

F6=ROLL

Returns to the NetView command line without exiting NTuneMON. To return to NTuneMON from the NetView program, press F6=ROLL or enter **ATUNEMON** on the NetView command line.

F7=HPR/FC (if HPR resources are defined)

Displays the ATUHP HPR & Other Global Flow Control Params panel, as shown on page 4-153, to show HPR and other global flow control parameters.

F9=SLDW Info

Displays the ATUBS Buffer Slowdown Information Page 1 panel, as shown on page 4-10, to show the first-failure-data-capture (FFDC) data that was captured during an NCP slowdown.

F10=HEX

Displays the ATUDP Hexadecimal Storage Display panel, as shown on page 4-68, to show the destination boundary pool (BPOOL) block for a network (BPB).

F12=REFRESH

Refreshes the information on this panel.

PA1=EXIT

Exits NTuneMON.

PA2=LOG

Saves the information on this panel to the NetView log.

ATUBS Buffer Slowdown Information Page 1 Panel

Basic fast-path commands: BS, SLOWDOWN

Tuning fields: None

```

ATUBS  A04SUP3  Buffer Slowdown Information PG1  NTuneMON V2R5      07:58
CCU = 21      Date:06/16/1998      Time: 07.37.39
      Buffer Status      VR/TG Status
Initial Buffers = 57397      Total VR Xmit Que = 0
Current Buffers = 7187      VR and Xmit Pri = 0-0
Enter Slowdown = 7174      PIU's VR XMIT (LG)= 0
Exit Slowdown = 10761      Dest SA/Origin SA = 0/0
Committed Count = 3688      VR NETID = N/A
BPool Status = OKAY      VR Status = 00
BPool Buffers = 25111
BPool Allocation= 0

SUM of BYTES MLTG = 0
Bytes Single MLTG = 0
Adj SA / TG Number= 0 / 0
TG Netid =

NSA Status = 60      Total Boundary Sessions
Buffers NSA Que = 0      Inbound PIU's = 0
NSP Status = 00      Inbound Data = 0
Buffers NSP Que = 0      Outbound PIU's = 0
Buffers SNQ Que = 0      Outbound Data = 0

=>
F1=HELP  F3=RTN  F6=ROLL  F8=FWD  F10=HEX  F12=RFRSH  PA1=EXIT  PA2=LOG

```

Figure 4-3. ATUBS Buffer Slowdown Information Page 1 Panel

Description

The ATUBS Buffer Slowdown Information Page 1 panel displays page 1 of the first-failure-data-capture (FFDC) information that is captured when the NCP enters a slowdown. The ATUBS panel is available for:

- NCP V7R5 and later
- NCP V7R2, V7R3, or V7R4 if APAR IR32588 is installed.

To display this panel: On the ATUBP NCP Buffer Pool panel, as shown on page 4-4, press F9.

Fields

NCP name (second field on panel)

Name of the NCP that is currently displayed.

CCU

Percentage of controller CCU cycles in use.

Date

Date when the slowdown occurred.

Time

Time when the slowdown occurred.

Buffer Status

Initial Buffers

Initial free buffer count when the slowdown occurred.

Current Buffers

Current free buffer count when the slowdown occurred.

Enter Slowdown

Enter-slowdown threshold when the slowdown occurred.

Exit Slowdown

Exit-slowdown threshold when the slowdown occurred.

Committed Count

Global committed count when the slowdown occurred.

BPool Status

Status of the destination buffer boundary pool (BPOOL). One of the following. OKAY is displayed in green; any other status is displayed in red.

- OKAY
- BPOOL full
- Reset window high
- Reset window medium
- Reset window low

BPool Buffers

Number of buffers in the BPOOL.

BPool Allocation

Number of buffers allocated in the BPOOL when the slowdown occurred.

Performance Collection Status and Statistics

This information appears in the lower left area of the screen.

NSA Status

Status of NPA session accounting (NSA). For information on the contents of this byte, see the NSASSTAT field in the NSA control block in *NCP and EP Reference Summary and Data Areas*.

Buffers NSA Que

Number of buffers on the NSA queue.

NSP Status

Status of NPA session processing (NSP). For information on the contents of this byte, see the NSPSTAT field in the NSP control block in *NCP and EP Reference Summary and Data Areas*.

Buffers NSP Que

Number of buffers on the NSP queue.

Buffers SNQ Que

Number of buffers on the ODLC/NMVT queue (SNQ).

VR/TG Status

Total VR Xmit Que

Total number of PIUs on all virtual route transmit queues.

VR and Xmit Pri

Virtual route number and virtual route transmission priority of the VRB with the largest queue.

PIU's VR XMIT (LG)

Number of PIUs on the virtual route transmit queue of the VRB with the largest queue.

Dest SA/Origin SA

Destination subarea and origin subarea of the virtual route with the largest queue.

VR NETID

Network ID of the virtual route with the largest queue.

VR Status

Status of the virtual route with the largest queue. This field is color-coded as follows:

Color	Status
Turquoise	Normal
Pink	Warning
Red	Error

For more detailed information on the contents of this byte, see the VRBFCFLG field in the VRB control block in *NCP and EP Reference Summary and Data Areas*.

SUM of BYTES MLTG

Total number of bytes on all MLTG transmit queues.

Bytes Single MLTG

Total number of bytes on the MLTG transmit queue that has the most data queued for transmission.

Adj SA / TG Number

Adjacent subarea number and TG number of the TG with the most data.

TG Netid

Network ID of the TG with the most data.

Total Boundary Sessions

Inbound PIU's

Total number of inbound PIUs queued for all boundary sessions.

Inbound Data

Total number of inbound data bytes queued for all boundary sessions.

Outbound PIU's

Total number of outbound PIUs queued for all boundary sessions.

Outbound Data

Total number of outbound data bytes queued for all boundary sessions.

PF Keys

F1=HELP

Displays online help for this panel.

F3=RTN

Returns to the previous NTuneMON panel.

F6=ROLL

Returns to the NetView command line without exiting NTuneMON. To return to NTuneMON from the NetView program, press F6=ROLL or enter **ATUNEMON** on the NetView command line.

F8=FWD

Displays the ATUBX Buffer Slowdown Information Page 2 panel, as shown on page 4-14.

F10=HEX

Displays the ATUDP Hexadecimal Storage Display panel, as shown on page 4-68, to show the SDG control block.

F12=RFRSH

Refreshes the information on this panel.

PA1=EXIT

Exits NTuneMON.

PA2=LOG

Saves the information on this panel to the NetView log.

ATUBX Buffer Slowdown Information Page 2 Panel

Basic fast-path commands: BX
 Tuning fields: None

```

ATUBX  A04NT02  Buffer Slowdown Information PG2  NTuneMON V2R3  09:56
      Total Inbound / Outbound Single Station
Inbound PIU's = 0      Outbound PIU's = 0
Inbound Data = 0      Outbound Data = 0
  Netid - Name          Netid - Name
  -                    -
-----
      Total Inbound / Outbound Single Logical Unit
Inbound PIU's = 0      Outbound PIU's = 1
Inbound Data = 0      Outbound Data = 69
  Netid - Name          Netid - Name
  -                    NETA -ECH001
-----
      Inbound Sessions          Outbound Sessions
PIU Count = 0      PIU Count = 1
Byte Count = 0      Byte Count = 69
Subarea Pacing =      REX Pacing = 160
-----
      Inbound Partners          Outbound Partners
      Netid - Name              Netid - Name
      -                          -
=>
F1=HELP  F3=RTN  F6=ROLL  F7=BACK  F10=HEX  F12=RFRSH  PA1=EXIT  PA2=LOG
    
```

Figure 4-4. ATUBX Buffer Slowdown Information Page 2 Panel

Description

The ATUBX Buffer Slowdown Information Page 2 panel displays page 2 of the first-failure-data-capture (FFDC) information that is captured when the NCP enters a slowdown. The ATUBX panel is available for:

- NCP V7R5 and later
- NCP V7R2, V7R3, or V7R4 if APAR IR32588 is installed.

To display this panel: On the ATUBS Buffer Slowdown Information Page 1 panel, as shown on page 4-10, press F8.

Fields

NCP name (second field on panel)

Name of the NCP that is currently displayed.

Total Inbound / Outbound Single Station

Inbound PIU's

Total number of inbound PIUs queued for all sessions on the station with the most inbound data queued.

Inbound Data

Total number of inbound data bytes queued for all sessions on the station with the most inbound data queued.

Netid

Network ID of the station with the most inbound data queued.

Name

Name of the station with the most inbound data queued.

Outbound PIU's

Total number of outbound PIUs queued for all sessions on the station with the most outbound data queued.

Outbound Data

Total number of outbound data bytes queued for all sessions on the station with the most outbound data queued.

Netid

Network ID of the station with the most outbound data queued.

Name

Name of the station with the most outbound data queued.

Total Inbound / Outbound Single Logical Unit

Inbound PIU's

Total number of inbound PIUs queued for all sessions on the LU with the most inbound data queued.

Inbound Data

Total number of inbound data bytes queued for all sessions on the LU with the most inbound data queued.

Netid

Network ID of the LU with the most inbound data queued.

Name

Name of the LU with the most inbound data queued.

Outbound PIU's

Total number of outbound PIUs queued for all sessions on the LU with the most outbound data queued.

Outbound Data

Total number of outbound data bytes queued for all sessions on the LU with the most outbound data queued.

Netid

Network ID of the LU with the most outbound data queued.

Name

Name of the LU with the most outbound data queued.

Inbound Sessions

PIU Count

Number of inbound PIUs queued for the session with the most inbound data queued.

Byte Count

Number of inbound data bytes queued for the session with the most inbound data queued.

Subarea Pacing

Subarea stage transmit pace status of the session with the most inbound data queued. For information on the contents of this byte, see the SDSATPI field in the SDS control block in *NCP and EP Reference Summary and Data Areas*.

Outbound Sessions

PIU Count

Number of outbound PIUs queued for the session with the most outbound data queued.

Byte Count

Number of outbound data bytes queued for the session with the most outbound data queued.

REX Pacing

Rex stage transmit pace status of the session with the most outbound data queued. For information on the contents of this byte, see the SDSXTPI field in the SDS control block in *NCP and EP Reference Summary and Data Areas*.

Inbound Partners

Netid

Session partner network IDs of the session with the most inbound data queued.

Name

Session partner names of the session with the most inbound data queued.

Outbound Partners

Netid

Session partner network IDs of the session with the most outbound data queued.

Name

Session partner names of the session with the most outbound data queued.

PF Keys

F1=HELP

Displays online help for this panel.

F3=RTN

Returns to the previous NTuneMON panel.

F6=ROLL

Returns to the NetView command line without exiting NTuneMON. To return to NTuneMON from the NetView program, press F6=ROLL or enter **ATUNEMON** on the NetView command line.

F7=BACK

Displays the ATUBS Buffer Slowdown Information Page 1 panel, as shown on page 4-10.

F10=HEX

Displays the ATUDP Hexadecimal Storage Display panel, as shown on page 4-68, to show the SDS control block.

F12=RFRSH

Refreshes the information on this panel.

PA1=EXIT

Exits NTuneMON.

PA2=LOG

Saves the information on this panel to the NetView log.

ATUCB Control Block Pools/Tables Panel

Basic fast-path commands: CB, CBPOOL

Tuning fields: None

ATUCB A71TEST		Control Block Pools / Tables				Page 1	NTuneMON V2R4		18:15	
		CCU = 0%		Storage = 1%						
NCP CB POOLS	MAX USE	CUR USE	ALERT THRSH	MAX USE	CUR USE	FREE UNRSVD	FREE RSVD	TOTAL	DYNA	PERM ASSIGN
HSCB	0%	0%	80%	0	0	0	0	0	0	0
PUDR	88%	88%	80%	76	76	10	0	86	0	567
LUB	0%	0%	80%	0	0	22	0	22	0	0
LND	0%	0%	80%	0	0	12	0	12	0	0
LNB	0%	0%	80%	0	0	510	0	510	0	0
BSB	0%	0%	80%	0	0	910	0	910	0	0
LTX	0%	0%	80%	0	0	2	0	2	0	0
NUMHSAS	33%	33%	80%	3	3	6	0	9	N/A	0
NNT	0%	0%	80%	1	1	119	0	120	0	0
VVT	1%	1%	80%	3	3	254	0	257	N/A	0
NSX	0%	0%	80%	0	0	500	0	500	0	0
NSC	0%	0%	80%	0	0	500	0	500	0	0
LUX	0%	0%	80%	0	0	0	0	0	0	0
FCT	32%	32%	80%	120	120	254	0	374	N/A	0
TR LLB	0%	0%	80%	0	0	100	0	100	N/A	9
ODLC LAN	0%	0%	80%	0	0	100	0	100	N/A	4

=>
F1=HELP F2=BUFPOOL F3=RETURN F4=NETWORK F5=OWNERPL F6=ROLL F7= BACK
F8=FORWARD F10=HEX F12=REFRESH PA1=EXIT PA2=LOG

Figure 4-5. ATUCB Control Block Pools/Tables Panel Page 1 of 3

ATUCB A71TEST		Control Block Pools / Tables				Page 2	NTuneMON V2R4		18:25	
		CCU = 0%		Storage = 1%						
NCP CB POOLS	MAX USE	CUR USE	ALERT THRSH	MAX USE	CUR USE	FREE UNRSVD	FREE RSVD	TOTAL	DYNA	PERM ASSIGN
FR LLB	0%	0%	80%	0	0	125	0	125	N/A	10
ODLC FR	0%	0%	80%	0	0	100	0	100	N/A	130
ISDN PN	0%	0%	80%	0	0	99	0	99	N/A	0
ISDN SA	0%	0%	80%	0	0	99	0	99	N/A	0
HRE	0%	0%	80%	0	0	10	0	10	0	17
NRE	3%	3%	80%	1	1	30	0	31	0	16
SRE	0%	0%	80%	0	0	20	0	20	0	0
LAE	0%	0%	80%	0	0	10	0	10	0	16
RIB	0%	0%	80%	0	0	10	0	10	0	16
ENI	0%	0%	80%	0	0	10	0	10	0	16
NQE	0%	0%	80%	0	0	1008	0	1008	N/A	0
NQ2	0%	0%	80%	0	0	1008	0	1008	N/A	0
NQX	0%	0%	80%	0	0	0	0	0	N/A	0
NSB	0%	0%	80%	0	0	44	0	44	N/A	0
RVT	0%	0%	80%	0	0	0	0	0	0	2276
NVT	0%	0%	80%	0	0	0	0	0	N/A	1

=>
F1=HELP F2=BUFPOOL F3=RETURN F4=NETWORK F5=OWNERPL F6=ROLL F7= BACK
F8=FORWARD F10=HEX F12=REFRESH PA1=EXIT PA2=LOG

Figure 4-6. ATUCB Control Block Pools/Tables Panel Page 2 of 3

ATUCB Control Block Pools/Tables Panel

ATUCB		A27GENC		Control Block Pools / Tables				Page 3		NTuneMON V2R6		13:49	
		CCU =		0%		Storage =		2%					
NCP	CB	MAX	CUR	ALERT	MAX	CUR	FREE	FREE	TOTAL	DYNA	PERM		
POOLS		USE	USE	THRSH	USE	USE	UNRSVD	RSVD			ASSIGN		
SNP		25%	25%	<u>80%</u>	2	2	6	0	8	N/A	0		
CRX		0%	0%	<u>80%</u>	0	0	5	0	5	0	251		
LXE		0%	0%	<u>80%</u>	0	0	0	0	0	0	0		

=>
F1=HELP F2=BUFPPOOL F3=RETURN F4=NETWORK F6=ROLL F7= BACK
F8=FORWARD F10=HEX F12=REFRESH PA1=EXIT PA2=LOG

Figure 4-7. ATUCB Control Block Pools/Tables Panel Page 3 of 3

Description

The ATUCB Control Block Pools/Tables panel provides information on the use of NCP control block pools. This panel does not include control block pools defined on a per-network basis. For information on network control block pools, see "ATUGP Network CB Pools/Tables Panel" on page 4-149.

To display this panel:

- From the second PF key selection of the ATUNP NCP Selection panel, as shown on page 4-204, press F2.
- From the first PF key selection of the ATUCD CDS NCP Selection panel, as shown on page 4-27, press F2.
- From the second PF key selection of the ATUNW NCP Wide Selection panel, as shown on page 4-212, press F2.
- From the first PF key selection on the ATUSS Summary Status panel, as shown on page 4-260, press F8.
- From the second PF key selection on the ATUSS Summary Status panel, as shown on page 4-260, press F2.
- From the ATUUT NCP Utilization panel, as shown on page 4-328, press F2.
- From the ATUGP Network CB Pools/Tables panel, as shown on page 4-149, press F2.
- From the ATUBP NCP Buffer Pool panel, as shown on page 4-4, press F2.

Fields

NCP name (second field on panel)

Name of the NCP that is currently displayed. You can enter a different NCP name in this field to display information about another NCP.

CCU

Percentage of controller CCU cycles in use.

STORAGE

Percentage of controller buffer storage in use.

NCP CB POOLS

NCP keeps track of control block usage for many control block pools. Unless otherwise noted, these CB pools can be dynamically created for NCP V7R1 and later releases using the dynamic CB function. See the *NCP and EP Reference* publication for more information.

If you have NTuneNCP and NCP V7R1 or a later NCP release, you can tune the DYNPOOL keyword to dynamically create control blocks for you. See Chapter 5, "Using the NTuneNCP Tuning Feature" on page 5-1 for more information.

Control Blocks: The first column of this panel lists the following control blocks and tables.

HSCB (starting with NCP V6R2)

Half-session control blocks (NIX/NLX pairs) as defined by the HSPOOL keyword on the BUILD statement. Two unique HSCBs are used for each cross-network SNI session, one in each network.

HSCBs as defined by the NUMSESS keyword on the GWNAU statement are considered permanently assigned; therefore, they are not included in TOTAL.

PUDR (starting with NCP V6R2)

Common PU blocks (CUBs) in the PU dynamic reconfiguration (PUDR) pool, as defined by the NUMBER keyword on the PUDRPOOL statement and Type 1 and Type 2 PUs (CUBs) coded with PUDR=YES on the PU definition statement.

Type 1 and Type 2 PUs coded with PUDR=NO are considered permanently assigned; therefore, they are not included in TOTAL.

Associated minor control blocks are:

- CXB
- CXI
- CX2 (for NCP V7R2 and later releases)
- CBB
- RVT (dynamic entries)
- SCE (for 3746 Model 900 PUs)
- SSB (for 3746 Model 900 ESCA PUs)

LUB

LU control blocks, for dynamically added LUs and switched LUs (Token-Ring), as defined by the NUMILU, NUMTYP1, and NUMTYP2 keywords on the LUDRPOOL statement and LUs coded with LUDR=YES on the LU statement.

LUs coded with LUDR=NO are considered permanently assigned; therefore, they are not included in TOTAL.

LND (NCP V4R3.1 or later releases)

Dependent LU boundary session control blocks, dynamically added through dynamic reconfiguration or switched lines, as defined by the NUMTYP1 and NUMTYP2 keywords on the LUDRPOOL statement and dependent LUs (for example, LOCADDR not equal to 0 on the LU statement) coded with LUDR=YES on the LU statement.

LUs coded with LUDR=NO are considered permanently assigned; therefore, they are not included in TOTAL.

LNB (NCP V4R3.1 or later releases)

LU address control blocks, for element addresses for independent LUs.

The NUMILU keyword on the LUDRPOOL statement defines LNBs for dynamically added or switched independent LUs.

The AUXADDR keyword on the BUILD statement defines one LNB for each additional address that can be assigned to any of the peripheral LUs.

LU statements for independent LUs (for example, LOCADDR=0 on the LU statement), also define LNBs.

LNBs for LUs defined with LUDR=NO are considered permanently assigned; therefore, they are not included in TOTAL.

An LU requires an additional address for each PLU.

BSB (NCP V4R3.1 or later releases)

Boundary session control blocks, for LU-LU session information for independent LUs. A BSB is defined for each independent LU.

The NUMILU keyword on the LUDRPOOL statement defines BSBs for dynamically added independent LUs.

The ADDSESS keyword on the BUILD statement defines additional BSBs for independent LU sessions for use by any independent LU.

The AUXADDR keyword on the BUILD statement defines one BSB for each additional address (see AUXADDR under LNB preceding).

The RESSCB keyword on the LU statement defines additional BSBs to be reserved for specific independent LUs.

LTX (NCP V4R3.1 or later releases)

LU terminal node extension, for dynamically added LUs under a type 1 PU, as defined by the NUMTYP1 keyword on the LUDRPOOL statement.

NUMHSAS (starting with NCP V6R2)

Number of subareas (VST/VAT entries), as defined by the NUMHSAS keyword on the BUILD and NETWORK statements. Define one for each host subarea that can communicate with this NCP and one for each subarea in the nonnative network that has virtual routes ending in this NCP.

Notes:

1. If you code an excessive value for NUMHSAS, you could waste NCP storage.
2. NUMHSASs cannot be created dynamically with the NCP dynamic control block function.

NNT (NCP V4R3.1 or later releases)

Network names table entries, as defined by the NAMTAB keyword on the BUILD statement. Each unique CPNAME and NETID requires one table entry.

VVT (starting with NCP V6R2)

Virtual route vector table entries, as defined by the VRPOOL keyword on the BUILD statement.

VVT entries cannot be dynamically created with the NCP dynamic control block function.

NSX (NCP V4R3.1 or later releases)

Network performance analyzer (NPA) session counter extension blocks, for NPM session accounting for LU-LU sessions, as defined by the GWSESAC and SESSACC keywords on the BUILD statement.

NSC (NCP V4R3.1 or later releases)

NPA session counters, for PIU and byte counts on LU-LU sessions, as defined by the GWSESAC and SESSACC keywords on the BUILD statement.

LUX (starting with NCP V6R2)

Extended recovery facility (XRF) LU block extensions, as defined by the BACKUP keyword on the BUILD statement.

FCT (starting with NCP V7R1)

Flow control parameter table entries, as defined by the VRPOOL keyword on the BUILD statement.

FCTs cannot be dynamically created with the NCP dynamic control block function.

TR LLB (starting with NCP V7R1)

Token-Ring logical link blocks, as defined by ECLTYPE=LOGICAL on the GROUP statement. Only TR LLBs for which either PHYPORT=NONE or PHYSRSC=NONE are also defined on the GROUP statement belong to the pool. The remainder are considered permanently assigned.

If the OWNERPL function is being used for this pool (NTRI is specified on the OWNERPL keyword on the BUILD statement), then F5=OWNERPL provides additional information about the FREE UNRSVD count.

TR LLBs cannot be dynamically created with the NCP dynamic control block function.

ODLC LAN (starting with NCP V7R1)

Outboard data link control local area network logical resources, as defined by ECLTYPE=LOGICAL on the GROUP statement.

The only ODLC LAN logicals that belong to the pool are those for which the GROUP statement also defines one of the following:

- PHYSRSC=(NONE,TIC3)
- PHYSRSC=(NONE,ODLC)
- PHYPORT=(NONE,ODLC) — starting with NCP V7R8

The remaining ODLC LAN logicals are considered permanently assigned.

If the OWNERPL function is being used for this pool (ODLCTR is specified on the OWNERPL keyword on the BUILD statement), then F5=OWNERPL provides additional information about the FREE UNRSVD count.

ODLC LANs cannot be dynamically created with the NCP dynamic control block function.

FR LLB (starting with NCP V7R1)

Frame-relay logical link blocks, as defined by FRELAY=LOGICAL on the GROUP statement. Only FR LLBs for which PHYSRSC=NONE is also defined on the GROUP statement belong to the pool. The remainder are considered permanently assigned.

If the OWNERPL function is being used for this pool (FR is specified on the OWNERPL keyword on the BUILD statement), then F5=OWNERPL provides additional information about the FREE UNRSVD count.

FR LLBs cannot be dynamically created with the NCP dynamic control block function.

ODLC FR (starting with NCP V7R2)

Outboard data link control frame-relay logical resources, as defined by FRELAY=LOGICAL on the GROUP statement. Only ODLc frame-relay logicals for which PHYSRSC=(NONE,ODLC) is also defined on the GROUP statement belong to the pool. The remainder are considered permanently assigned.

If the OWNERPL function is being used for this pool (ODLCFR is specified on the OWNERPL keyword on the BUILD statement), then F5=OWNERPL provides additional information about the FREE UNRSVD count.

ODLC FRs cannot be dynamically created with the NCP dynamic control block function.

ISDN PN (starting with NCP V7R5)

ISDN peripheral logical resources, as defined by ISDN=(LOGICAL,PERipheral) on the GROUP statement.

If the OWNERPL function is being used for this pool (ISDN is specified on the OWNERPL keyword on the BUILD statement), then F5=OWNERPL provides additional information about the FREE UNRSVD count.

ISDN PNs cannot be created dynamically with the NCP dynamic control block function.

ISDN SA (starting with NCP V7R5)

ISDN subarea logical resources, as defined by ISDN=(LOGICAL,SUBarea) on the GROUP statement.

If the OWNERPL function is being used for this pool (ISDN is specified on the OWNERPL keyword on the BUILD statement), then F5=OWNERPL provides additional information about the FREE UNRSVD count.

ISDN SAs cannot be created dynamically with the NCP dynamic control block function.

HRE (starting with NCP V7R1)

Host route entries, as defined by the NUMROUTE keyword on the IPOWNER statement.

NRE (starting with NCP V7R1)

Network route entries, as defined by the NUMROUTE keyword on the IPOWNER statement.

SRE (starting with NCP V7R1)

Subnetwork route entries, as defined by the NUMROUTE keyword on the IPOWNER statement.

LAE (starting with NCP V7R3)

Number of local address entry control blocks for dynamically added IP resources on a frame-relay line. Defined by the NUMDRIF keyword on the IPOWNER statement.

RIB (starting with NCP V7R3)

Number of route interface control blocks, for dynamically added IP resources on a frame-relay line. Defined by the NUMDRIF keyword on the IPOWNER statement.

ENI (starting with NCP V7R3)

Number of IP/DLC control blocks, for dynamically added IP resources on a frame-relay line. Defined by the NUMDRIF keyword on the IPOWNER statement.

NQE (starting with NCP V7R1)

NPA counter queue elements, as defined by the MAXCOLL keyword on the NPA LU statement. The maximum number of NQEs available is based on the NDF calculated value or MAXCOLL, whichever is less. This is to prevent the wasting of NCP storage.

NQEs cannot be dynamically created with the NCP dynamic control block function.

NQ2 (starting with NCP V7R1)

NPA counter queue elements, as defined by the MAXCOLL keyword on the NPA LU statement.

NQ2s cannot be dynamically created with the NCP dynamic control block function.

NQX (starting with NCP V7R1)

NPA counter queue element extensions, as defined by the MAXTP keyword on the NPA LU statement.

NQXs cannot be dynamically created with the NCP dynamic control block function.

NSB (starting with NCP V7R1)

NPM frame-relay physical station data blocks, as defined by the FRSEDRPU keyword on the PUDRPOOL statement.

NSBs cannot be dynamically created with the NCP dynamic control block function.

RVT (starting with NCP V7R1)

Resource vector table entries, based on the number of resources with element addresses.

NVT (starting with NCP V7R1)

Network vector table entries, as defined by the COPIES keyword on the NETWORK statement and the number of networks generated.

Notes:

1. NVT entries for networks that are not dynamic are considered permanently assigned; therefore, they are not included in TOTAL.
2. NVTs cannot be dynamically created with the NCP dynamic control block function.

SNP (starting with NCP V7R1)

SSCP-NCP session control blocks, as defined by the MAXSSCP keyword on the BUILD statement.

SNPs cannot be dynamically created with the NCP dynamic control block function.

CRX (starting with NCP V7R3)

Frame-relay communications rate control blocks, for dynamically added frame-relay frame handler supports (FHSPs), as defined by the FRDRCNT suboperand of the FRSEDRPU keyword on the PUDRPOOL statement.

LXE (starting with NCP V7R8)

LU control block extensions for XRF encryption as defined by the *tdes24* suboperand of the BACKUP keyword on the BUILD statement.

Use Information: The following use information is shown for each of the control block pools described previously.

MAX USE (%)

Highest percentage of control blocks in use since the NCP was loaded. When the maximum percentage of CBs in use reaches the ALERT THRSR value, the percent is highlighted in reverse-video red. A generic alert is issued (if specified).

CUR USE (%)

Control blocks currently in use, shown as a percentage of the total number of non-dynamic control blocks currently in the pool. This field is highlighted in reverse-video red when it reaches the ALERT THRSR value. A generic alert is issued (if specified). If this happens, you might want to increase the number of generated resources and regenerate the NCP.

ALERT THRSR

Alert threshold for control block use for each control block pool.

If the current or maximum control block percentages reach this value, the percentage fields are highlighted in reverse-video red.

NTuneMON keeps track of the maximum percent of control blocks in use. When the current maximum percent of control blocks in use exceeds the maximum percent in use NTuneMON has detected so far, it issues a generic alert (if specified). The current maximum percent then becomes the value that determines when the next generic alert is sent.

You can enter values in this column to change the alert threshold for each pool. You can make the alert threshold greater than 100 if you want no alerts to be issued.

MAX USE

Highest number of control blocks in use since the NCP was loaded.

CUR USE

Number of control blocks currently in use.

FREE UNRSVD

Number of free control blocks in the unreserved control block pool. Control blocks in the unreserved control block pool can be used by any appropriate resource.

When the OWNERPL function is being used, F5=OWNERPL provides additional information about the FREE UNRSVD count for the following resources: TR LLB, ODLC LAN, FR LLB, ODLC FR, ISDN PN, and ISDN SA.

Note: The FREE UNRSVD count on this panel includes all of the logical resources that are allocated to a specific physical resource. These resources might be inactive or might be in a connectable (CONCT) state.

FREE RSVD

Number of free control blocks in the reserved control block pool. The number of reserved control blocks depends on the particular pool. The reserved pool is used only for the following control blocks:

- For the BSB pool, the count is the number of reserved BSBs created as a result of the value coded for the RESSCB keyword on the LU statements and the number of BSBs reserved by dynamic reconfiguration (DR).
- For the FCT, for NCP V7R1 or later releases, the count is the number of FCT entries reserved for use by a specific network, that is, generated from the VRPWS keyword on the PATH statement for dynamic networks.
- For resources with element addresses (CUB, LNB, LND), for NCP V7R1 or later releases, the count is the number of currently free control blocks that have pre-ENA addresses.

Note: The MAXSUBA keyword coded on the BUILD statement determines the range of pre-ENA addresses.

TOTAL

Total number of control blocks defined for the pool. This total is the sum of CUR USE count, FREE UNRSRVD, and FREE RSRVD. This total does not include control blocks permanently assigned to a particular resource.

DYNA

Number of control blocks currently in use that were dynamically created in buffers using the NCP V7R1 dynamic control block function. If the control block cannot be dynamically created with the NCP dynamic control block function, this field contains N/A. If this field contains a non-zero value, it is highlighted in reverse-video pink. If there are dynamic control blocks, you might want to increase the number of resources generated and regenerate the NCP.

PERM ASSIGN (starting with NCP V7R1)

Number of control blocks permanently assigned to a particular resource. These control blocks are not included in any of the other counts or calculations. See the individual control block pool descriptions for details. There are no permanently assigned resources unless otherwise specified.

PF Keys

F1=HELP

Displays online help for this panel.

F2=BUFPOOL

Displays the ATUBP NCP Buffer Pool panel, as shown on page 4-4, to show information about NCP buffer pool usage.

F3=RETURN

Returns to the previous NTuneMON panel.

F4=NETWORK

Displays the ATUNG HSCBs and GWNAUs panel, as shown on page 4-195, to show information on the use of HSCBs and GWNAUs for an NCP. Valid for NCP V6R2 or later releases.

F5=OWNERPL (available if the NCP was generated with the OWNERPL keyword)

Displays the ATUCX Control Block Pools Extension panel, as shown on page 4-47, to provide additional information on the FREE UNRSVD resources when the OWNERPL function is being used.

The additional information applies to the following pools:

- TR LLB
- ODLC LAN
- FR LLB
- ODLC FR
- ISDN PN
- ISDN SA

F6=ROLL

Returns to the NetView command line without exiting NTuneMON. To return to NTuneMON from the NetView program, press F6=ROLL or enter **ATUNEMON** on the NetView command line.

F7=BACK

Scrolls the panel data backward one screen.

F8=FORWARD

Scrolls the panel data forward one screen.

F10=HEX

Displays the ATUDP Hexadecimal Storage Display panel, as shown on page 4-68, to show the queue anchor block (QAB).

F12=REFRESH

Refreshes the information on this panel.

PA1=EXIT

Exits NTuneMON.

PA2=LOG

Saves the information on this panel to the NetView log.

ATUCD CDS NCP Selection Panel

Basic fast-path commands: CD, CDS

Tuning fields: None

```

ATUCD NCPs= 2          CDS NCP Selection Panel          NTuneMON V2R5  11:17
NCP  SUBAREA  CNTL  MEM  S/N  EC LVL  FIX LVL  CDS DATE  TIER  CCU-MODE
A79SVTB  79    3745-41A 8MB  0003606 D39894A M894A055 98/03/18  5/A  TWIN-DUAL (A)
A80SVTB  80    3745-41A 8MB  0003606 D39894A M894A055 98/03/18  5/A  TWIN-DUAL (B)

=>
F1=HELP 2=CBPOOLS 3=RETURN 4=WIDE BUFS/UTIL 5=TGs 6=ROLL 7=BACK 8=FORWARD
ENTER=SUMMARY 9=TOKEN-RING 10=HEX 11=ALT-PFKS 12=REFRESH PA1=EXIT PA2=LOG

```

Figure 4-8. ATUCD CDS NCP Selection Panel

Description

The ATUCD CDS NCP Selection panel is similar to the ATUNP NCP Selection panel. Both panels list the active NCPs known to the VTAM host on which NTuneMON is running, and both panels provide quick access to more information on specific NCPs. (See “ATUNP NCP Selection Panel” on page 4-204 for details). The ATUCD CDS NCP Selection panel provides additional information on the maintenance level of each NCP and the communication controller in which it is running. Also, because this panel shows the controller serial number, you can see which NCPs are running on the same controller (3745 41x and 3745 61x in TWIN mode).

To display this panel:

- From the second PF key selection of the ATUNP NCP Selection panel, as shown on page 4-204, press F4.
- From the second PF key selection of the ATUNW NCP Wide Selection panel, as shown on page 4-212, press F4.

Fields

NCPs

Number of NCPs NTuneMON is monitoring. If you specified the monitoring of all NCPs when you started NTuneMON, this is the number of active NCPs known to the host on which NTuneMON is running. If you specified the monitoring of only certain NCPs, this is the number of those NCPs that are active.

The following columns on this panel show information for each NCP.

ATUCD CDS NCP Selection Panel

NCP

Names of active NCPs, as defined by the NEWNAME keyword on the BUILD statement.

SUBAREA

Subarea address (in decimal), as defined by the SUBAREA keyword on the BUILD statement.

CNTL

Communication controller model number, as defined by the MODEL keyword on the BUILD statement.

MEM

Controller storage, as defined by the MEMSIZE keyword on the BUILD statement.

S/N

Communication controller serial number.

EC LVL

Maintenance and operator subsystem (MOSS) microcode engineering change (EC) level (3745 only).

FIX LVL

MOSS microcode FIX level (3745 only).

CDS_DATE

Date the configuration data set (CDS) was last updated. This field is color-coded as follows:

- 20th-century (19xx) dates are shown in reverse-video red.
- 21st-century (20xx) dates are shown in reverse-video green.

TIER

Usage tiers, as defined by USGTIER (NCP V5R3 or later releases) and CSSTIER (NCP V6R2 or later releases with a 3746 Model 900) on the BUILD statement.

CCU-MODE

CCU operating mode (3745 41x and 61x only).

PF Keys

PF Key Selection Number 1

Figure 4-9 shows PF key selection number 1 for this panel. These alternate functions are enabled when you press F11=ALT-PFKS three times after first displaying panel ATUCD. The alternate functions are described following the figure.

Note: The default PF keys for panel ATUCD are PF key selection number 2, not PF key selection number 1.

```
=>  
F1=HELP 2=VRs 3=RETURN 4=SNI (HSCBs) 5=ADAPTERS 6=ROLL 7=BACK 8=FORWARD 9=NNTs  
ENTER=SUMMARY 10=UTILIZATION 11=ALT-PFKS 12=REFRESH PA1=EXIT PA2=LOG
```

Figure 4-9. PF Key Selection Number 1 for the ATUCD CDS NCP Selection Panel

F2=VRs

Displays the ATUVR Virtual Route panel, as shown on page 4-334, which provides information on all active virtual routes for an NCP. Place the cursor under an NCP name and press F2.

F4=SNI(HSCBs)

Displays the ATUNG HSCBs and GWNAUs panel (for NCP V6R2 or later releases) as shown on page 4-195, or the ATUNN HSCBs (Networks and HSCB Counts) panel (for earlier NCP releases), as shown on page 4-201. These panels provide information on half-session control blocks (HSCBs) and gateway network addressable units (GWNAUs) for an NCP. Place the cursor under an NCP name and press F4.

F5=ADAPTERS

Displays the ATUSC1 Channel Adapters panel, as shown on page 4-230, which provides information on 3745 channel adapters for an NCP. Place the cursor under an NCP name and press F5.

F9=NNTs

Displays the ATUNT NCP Network Names Table panel, as shown on page 4-209, which displays network names table entries and use counts for an NCP. Place the cursor under an NCP name and press F9.

F10=UTILIZATION

Displays the ATUUT NCP Utilization panel, as shown on page 4-328, which provides information on NCP CCU and buffer use for an NCP. Place the cursor under an NCP name and press F10.

F11=ALT-PFKS

Resets the PF keys on this panel to perform their original functions as described under "PF Key Selection Number 2."

PF Key Selection Number 2

This is the default set of PF keys for this panel. (See the bottom of Figure 4-8 on page 4-27.)

F1=HELP

Displays online help for this panel.

F2=CBPOOLS

Displays the ATUCB Control Block Pools/Tables panel, as shown on page 4-17, which provides information on the use of NCP control block pools. Place the cursor under an NCP name and press F2.

F3=RETURN

Returns to the previous NTuneMON panel.

F4=WIDE BUFS/UTIL

Displays the ATUNW NCP Wide Selection panel, as shown on page 4-212, which provides additional information on active NCPs, including information on the maintenance level of each NCP and the communications controller in which it is running.

F5=TGs

Displays the ATUTG Transmission Group panel, as shown on page 4-294, which provides information on transmission groups for an NCP. Place the cursor under an NCP name and press F5.

F6=ROLL

Returns to the NetView command line without exiting NTuneMON. To return to NTuneMON from the NetView program, press F6=ROLL or enter **ATUNEMON** on the NetView command line.

F7=BACK

Scrolls the panel data backward one screen.

F8=FORWARD

Scrolls the panel data forward one screen.

ENTER=SUMMARY

Displays the ATUSS Summary Status panel, as shown on page 4-260, which shows a wide variety of information for one NCP. Place the cursor under an NCP name and press Enter.

F9=TOKEN-RING (starting with NCP V5R4)

Displays the ATUTC Token-Ring Adapter List panel, as shown on page 4-278, which provides information on Token-Ring physical lines for an NCP. Place the cursor under an NCP name and press F9.

F10=HEX

Displays the ATUDP Hexadecimal Storage Display panel, as shown on page 4-68, to show the configuration data set control block (CDS). Place the cursor under an NCP name and press F10.

F11=ALT-PFKS

Resets some of the PF keys on this panel to perform different functions. These alternate PF keys are shown in Figure 4-10.

F12=REFRESH

Updates the list of active NCPs, depending on the FAST startup option (described on page 2-17).

PA1=EXIT

Exits NTuneMON.

PA2=LOG

Saves the information on this panel to the NetView log.

PF Key Selection Number 3

Figure 4-10 shows the third set of PF keys for this panel. These alternate functions are enabled when you press F11=ALT-PFKS in the second PF key selection. The alternate functions are described following the figure.

```
=> ATUM022 PF keys have been set to selection number 3
F1=HELP 2=ETHERNET 3=RETURN 4=SDLC 5=FRAME RELAY 6=ROLL 7=BACK 8=FORWARD
9=IP STATS ENTER=SUMMARY 10=CSS 11=ALT-PFKS 12=REFRESH PA1=EXIT PA2=LOG
```

Figure 4-10. PF Key Selection Number 3 for the ATUCD CDS NCP Selection Panel

F2=ETHERNET (NCP V6R1 or later releases)

Displays the ATUEP Ethernet Adapter List panel, as shown on page 4-81, which provides information on Ethernet-type subsystem (ESS) adapters for an NCP. Place the cursor under an NCP name and press F2.

F4=SDLC

Displays another view of the ATUFC Physical Line List panel, as shown on page 4-94, which shows a list of all SDLC and CLP lines defined to this NCP.

F5=FRAME RELAY (NCP V6R1 or later releases)

Displays the ATUFC Physical Line List panel, as shown on page 4-94, which provides information on frame-relay physical lines for an NCP. Place the cursor under an NCP name and press F5.

F9=IP STATS (NCP V6R1 or later releases)

Displays the ATUIS IP Router Statistics Page 1 panel, as shown on page 4-175, which provides information on NCP Internet Protocol functions for an NCP. Place the cursor under an NCP name and press F9.

F10=CSS (starting with NCP V6R2)

Displays the ATUSC4 3746 Model 900 Adapters panel, as shown on page 4-237, which provides information on 3746 Model 900 connectivity subsystem (CSS) adapters for an NCP. Place the cursor under an NCP name and press F10.

F11=ALT-PFKS

Resets some of the PF keys on this panel to perform different functions. These alternate PF keys are shown in Figure 4-11.

PF Key Selection Number 4

Figure 4-11 shows the fourth set of PF keys for this panel. These alternate functions are enabled when you press F11=ALT-PFKS in the third PF key selection. The alternate functions are described following the figure.

```
=> ATUM022 PF keys have been set to selection number 4
F1=HELP 2=X25NPSI 3=RETURN 4=ISDN 6=ROLL 7=BACK 8=FORWARD
ENTER=SUMMARY 11=ALT-PFKS 12=REFRESH PA1=EXIT PA2=LOG
```

Figure 4-11. PF Key Selection Number 4 for the ATUCD CDS NCP Selection Panel

F2=X25NPSI

Displays the ATUXL X.25 MCH Physical Line List panel, as shown on page 4-350, to list the X.25 multichannel (MCH) physical lines.

F4=ISDN

Displays the ATUDL ISDN Physical Line Table panel, as shown on page 4-59, to list the ISDN physical lines that are defined for the selected NCP. Place the cursor under an NCP name and press F4.

F11=ALT-PFKS

Resets the PF keys on this panel to perform different functions. These alternate PF keys are shown in Figure 4-9 on page 4-28.

ATUCH Channel Adapter Details Panel

Basic fast-path commands: None
 Tuning fields: Network

```

ATUCH A13V7R8 Channel Adapter Details NTuneMON V2R6 13:37
Elapsed Time = 0
Adapter Position= 5 Type= CADS Name= A13CA5 Status= ACTIVE

  BUFFER PARAMETERS                THRESHOLDS
  UNITSZ          = 384             LOW = 800
  Max Receive Data= 32782          HIGH= 1600
  MAXBFRU GEN/CUR = 100/0

  PU INFORMATION                    CHANNEL TIMERS
  PU Name          = A13CP5          Attention Delay GEN/CUR (DELAY) = 0.0/0.0
  PU Status       = ACTIVE          Attention Timeout GEN/CUR (TIMEOUT)= 60/60
  PU Type         = T5              CA Slowdown Limit (CASDL) = 420
  Subarea.TG= 11.1
  Network         = NETA
  CPNAME         = N/A

                                POLLING
                                Negative Polls = 2688
                                Positive Polls = 0
                                Total Polls  = 2688

=>
F1=HELP          F3=RETURN          F6=ROLL
F10=HEX         F12=REFRESH,POLLING    PA1=EXIT    PA2=LOG
    
```

Figure 4-12. ATUCH Channel Adapter Details Panel

Description

The ATUCH Channel Adapter Details panel displays detailed information on CADS and BCCA channel adapters. For information on 3746 Model 900 adapters, see Figure 4-74 on page 4-237.

To display this panel: On the ATUSC1 Channel Adapters panel, as shown on page 4-230, tab the cursor under a channel adapter number and press Enter.

Fields

NCP name (second field on panel)

Name of the NCP that is currently displayed.

Elapsed Time

Amount of time that has passed from panel entry until the panel is refreshed or the amount of time that has passed since the statistics were last refreshed.

Adapter position

Channel adapter position.

Type

Adapter type: BCCA or CADS.

Name

Line name. This name is the label on the LINE statement.

Status

Physical line status: ACTIVE or INACTIVE.

BUFFER PARAMETERS

UNITSZ

Size of the VTAM channel read buffer (IOBUF), as defined by the UNITSZ keyword on the VTAM HOST statement.

Max Receive Data

Maximum amount of data, in bytes, that NCP can receive from the host. This is the value of the TRANSFR keyword on the PU statement times the value of the BFRS keyword on the BUILD statement minus the NCP buffer overhead.

MAXBFRU GEN/CUR

Defined (GEN) and current (CUR) number of read buffers allocated by VTAM to receive data from NCP. The GEN field is either the value initially defined by the MAXBFRU keyword on the VTAM HOST statement or the value subsequently negotiated between NCP and VTAM. CUR is the current working value that is either set or limited by GEN.

THRESHOLDS

LOW

Minor-congestion threshold (8 times the value of the MAXBFRU keyword on the PU statement).

HIGH

Major-congestion threshold (16 times the value of the MAXBFRU keyword on the PU statement).

PU INFORMATION

PU Name

PU name.

PU Status

PU status. One of the following:

ACTIVE	Active (normal data)
CONT PND	Contact pending
DISC PND	Discontact pending
INACT PD	Free-resource operation pending
INACTIVE	Reset
INOP PND	INOP pending
LL2 ACT	Link-level 2 active
LL2 PND	Link-level 2 pending
LOAD/DMP	Load/Dump/RPO active
PENDING	Contact and discontact pending
SIM PEND	Set Initialization Mode pending
XID PEND	XID pending with data
XID NODT	XID pending without data

PU Type

PU type: T2.1 (type 2.1), T5 (type 5), or T1 (type 1).

Subarea.TG

For a type 5 PU, NTuneMON displays the subarea address and transmission group number (in the form *sa.tgn*) if the PU has been contacted and is active. Otherwise, NTuneMON displays only the transmission group number (in the form *TGN=tgn*). The transmission group number is defined by the TGN keyword on the PU statement.

For a type 2.1 or type 1 PU, NTuneMON displays N/A.

ATUCH Channel Adapter Details Panel

Network

The network that contains the PU. Specified by the NETID keyword on the NETWORK definition statement.

CPNAME

For an active type 2.1 PU, NTuneMON displays the control point name. Otherwise, NTuneMON displays N/A.

CHANNEL TIMERS

Attention Delay GEN/CUR

Defined (GEN) and current (CUR) maximum interval, in seconds, that NCP delays from the time data is available to the host to the time the attention signal is presented to the channel. GEN is either the value from the NCP generation (DELAY keyword on the LINE statement) or the value resulting from subsequent NCP processing that overwrote the value from the NCP generation. CUR is the current working value and is either set or limited by GEN.

Attention Timeout GEN/CUR

Defined (GEN) and current (CUR) maximum interval, in seconds, that NCP waits for a response to an attention signal sent to the host before initiating channel discontact. GEN is either the value from the NCP generation (TIMEOUT keyword on the LINE statement) or the value resulting from subsequent NCP processing that overwrote the value from the NCP generation. CUR is the current working value and is either set or limited by GEN.

CA Slowdown Limit

Maximum interval, in seconds, that this link can block inbound data before signaling that the station is inoperative. Defined by the CASDL keyword on the LINE statement.

POLLING

This section of the panel displays statistics for negative, positive, and total polls. When this panel is first entered, polls are displayed as numbers. When F12 is pressed, polls are displayed as polls per second (*n*/Sec). However, any polls that are less than one per second are displayed as numbers.

A high rate of polling on a channel indicates a lot of idle channel time because channel polls are attention polls.

Negative polls or Neg polls/Sec

NCP has no data queued to send when the attention (poll) signal is sent.

Positive polls or Pos polls/Sec

NCP has data queued to send when the attention (poll) signal is sent.

Total polls or Total polls/Sec

Sum of positive and negative polls.

Notes:

- NCP V7R2 or later releases:** When the line is inactive, a zero (0) is displayed in these fields because no polling is taking place.
- NCP V7R1 and earlier releases:** A dash (–) is displayed in these fields instead of poll counts.
- If polling data is not currently being collected and if you have NTuneNCP included in your NCP, you can use the ATUST NCP Function Activation panel to activate polling data collection (NTUNECOL). Enter POLL on the command

line to fast-path to the ATUST NCP Function Activation panel as shown on page 6-147.

PF Keys

F1=HELP

Displays online help for this panel.

F2=IP DETAILS (if the channel has an IP address defined)

Displays the ATUID IP Interface Information Detail panel, as shown on page 4-164, to show details about a specific IP interface.

F3=RETURN

Returns to the previous NTuneMON panel.

F4=VERIFY

Attempts to verify the network ID that you typed in the Network field. NTuneMON will reply with a message that either indicates that the network ID was found or indicates that the network ID is not defined. For more information, see the description of the Network tuning field on page 6-10.

F5=MODIFY

Available after a network ID has been verified. Modifies the SCB control block with the **new** network ID.

F6=ROLL

Returns to the NetView command line without exiting NTuneMON. To return to NTuneMON from the NetView program, press F6=ROLL or enter **ATUNEMON** on the NetView command line.

F10=HEX

Displays the ATUDP Hexadecimal Storage Display panel, as shown on page 4-68, to show the channel adapter control block (CAB).

F11=CHAN IP STATS (if the channel has an IP address defined)

Displays the ATUCI Channel IP Statistics panel, as shown on page 4-36, to show IP statistics for a channel.

F12=REFRESH,POLLING

Refreshes the information on this panel to display polls per second instead of the number of polls since the last time the poll counter field wrapped.

PA1=EXIT

Exits NTuneMON.

PA2=LOG

Saves the information on this panel to the NetView log.

ATUCI Channel IP Statistics Panel

Basic fast-path commands: None
 Tuning fields: None

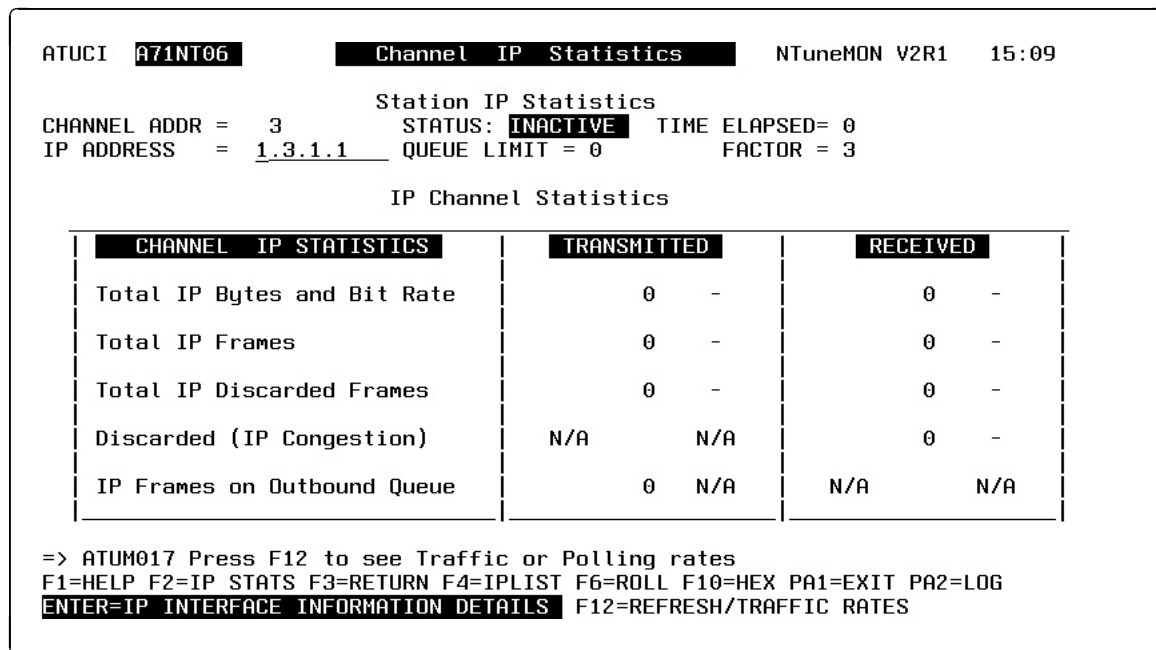

Figure 4-13. ATUCI Channel IP Statistics Panel

Description

The ATUCI Channel IP Statistics panel, which is available for NCP V7R3 or later releases, displays information about the station on the channel and IP traffic statistics for the channel.

To display this panel:

- From the ATUID IP Interface Information Detail panel, as shown on page 4-164, press F7.
- From the ATUCH Channel Adapter Details panel, as shown on page 4-32, press F11.
- From the ATUCL 3746-900 Station Details panel, as shown on page 4-39, press F11.

Fields

NCP name (second field on panel)

Name of the NCP that is currently displayed.

Station IP Statistics

This section of the panel provides information on the station defined on the channel.

CHANNEL ADDR

Channel address.

STATUS

Status of the station: ACTIVE or INACTIVE.

TIME ELAPSED

Amount of time that has passed since the statistics were last refreshed.

IP ADDRESS

Four-byte internet address of the associated interface as defined by the LADDR keyword on the PU or IPLOCAL statement.

QUEUE LIMIT

Maximum amount of data (in bytes) that can be queued for transmission as determined by multiplying the queue factor (always 3) by MAXBFRU by UNITSZ for the host.

FACTOR

Queue factor that is used in determining the queue limit. Queue factor is always 3.

IP Channel Statistics

The following fields show channel IP statistics for TRANSMITTED and RECEIVED counts and changes to the TRANSMITTED and RECEIVED rates. If the number of frames since the last refresh is greater than one per second, this value is shown as a number of frames per second (n/S). If the number of frames is less than one per second, the actual number of frames is shown. If information is not available, a dash (–) is displayed.

Total IP Bytes and Bit Rate

Number of bytes transmitted and received, and traffic rate in bits, megabits, or kilobits per second.

Total IP Frames

Number of frames transmitted and received.

Total IP Discarded Frames

Number of frames discarded.

Discarded (IP Congestion)

Number of frames discarded due to internet congestion. This information is not applicable (N/A) for the TRANSMITTED columns.

IP Frames on Outbound Queue

Number of frames on the outbound queue. This information is not applicable (N/A) for the TRANSMITTED change rate column or for the RECEIVED columns.

PF Keys

F1=HELP

Displays online help for this panel.

F2=IP STATS

Displays the ATUIS IP Router Statistics Page 1 panel, as shown on page 4-175, to show counters for IP datagrams and ICMP messages.

F3=RETURN

Returns to the previous NTuneMON panel.

F4=IPLIST

Displays the ATUIL IP Interface Information panel, as shown on page 4-169, to show information about an IP interface.

ATUCI Channel IP Statistics Panel

F6=ROLL

Returns to the NetView command line without exiting NTuneMON. To return to NTuneMON from the NetView program, press F6=ROLL or enter **ATUNEMON** on the NetView command line.

F10=HEX

Displays the ATUDP Hexadecimal Storage Display panel, as shown on page 4-68, to show the Ethernet statistical counters (ECT) control block.

PA1=EXIT

Exits NTuneMON.

PA2=LOG

Saves the information on this panel to the NetView log.

ENTER=IP INTERFACE INFORMATION DETAILS

Displays the ATUID IP Interface Information Detail panel, as shown on page 4-164, to show detailed information about an IP interface.

F12=REFRESH/TRAFFIC RATES

Refreshes the information on this panel and displays traffic rates.

ATUCL 3746-900 Station Details Panel

Basic fast-path commands: None

Tuning fields: Network

```

ATUCL  A12V7R8      3746-900 Station Details      NTuneMON V2R6  13:54

Physical Line= 2176 Type= ESCP Name= A12S2176 Status= ACTIVE
Logical Line HOSTLINK= 1(01) Name= A12LS0C1 Status= ACTIVE

  PU INFORMATION      BUFFER PARAMETERS      THRESHOLDS
  PU Addr   = 1(01)  UNITSZ           = N/A           LOW = N/A
  PU Name   = A12L1S1 Max Receive Data= 26382      HIGH= N/A
  PU Status = XID PEND MAXBFRU GEN/CUR = 32/32
  PU Type   = T5
  Subarea.TG= TGN=1
  Network   =
  CPNAME    = N/A

          PACING
          Cur Min Max
          1   1  10

  CHANNEL TIMERS
  Attention Delay GEN/CUR (DELAY) = 0.2/0.2
  Attention Timeout GEN/CUR (TIMEOUT)= 150/150
  CA Slowdown Limit (CASDL) = NONE

=>
F1=HELP          F3=RETURN          F6=ROLL
F10=HEX         F12=REFRESH       PA1=EXIT        PA2=LOG
  
```

Figure 4-14. ATUCL 3746-900 Station Details Panel

Description

The ATUCL 3746-900 Station Details panel displays detailed information on an ESCON logical station. This panel is available for NCP V6R2 or later releases. For this panel to be displayed, ESCON lines must be defined in the NCP generation and the 3746 Model 900 must be installed on the communication controller.

To display this panel: On the ATUCS 3746-900 Logical Lines panel, as shown on page 4-43, place the cursor under a station and press Enter.

Fields

NCP name (second field on panel)

Name of the NCP that is currently displayed.

Physical Line

Physical line address, as defined by the ADDRESS keyword on the LINE statement.

Type

Adapter type (ESCP)

Name

Physical line name.

Status

Physical line status: ACTIVE or INACTIVE.

Logical Line HOSTLINK

Logical line host link, as defined by the HOSTLINK keyword on the LINE statement. This is displayed in decimal and hexadecimal.

Name

Logical line name.

Status

Logical line status: ACTIVE or INACTIVE.

PU INFORMATION

PU Addr

PU address, as defined by the ADDR keyword on the PU statement. This is displayed in decimal and hexadecimal.

PU Name

PU name.

PU Status

PU status. This can be any of the following:

INACTIVE	Reset
ACTIVE	Active (normal data)
CONT PND	Contact pending
DISC PND	Discontact pending
INACT PD	Free-resource operation pending
INOP PND	INOP pending
LL2 ACT	Link-level 2 active
LL2 PND	Link-level 2 pending
LOAD/DMP	Load/Dump/RPO active
PENDING	Contact and discontact pending
SIM PEND	Set Initialization Mode pending
XID PEND	XID pending with data
XID NODT	XID pending without data

PU Type

PU type: T2.1 (type 2.1), T5 (type 5), or T1 (type 1).

Subarea.TG

For an active type 5 PU, NTuneMON displays the destination subarea address and transmission group number in the format *sa.tgn*. Otherwise, NTuneMON displays N/A.

Network

The network that contains the PU. Specified by the NETID keyword on the NETWORK definition statement.

CPNAME

For an active type 2.1 PU, NTuneMON displays the control point name. Otherwise, NTuneMON displays N/A.

BUFFER PARAMETERS

UNITSZ

Size of the VTAM channel read buffer (IOBUF), as defined by the UNITSZ keyword on the VTAM HOST statement.

Max Receive Data

Maximum amount of data, in bytes, that NCP can receive from the host. This is the value of the TRANSFR keyword on the PU statement times the BFRS keyword on the BUILD statement minus the NCP buffer overhead.

MAXBFRU GEN/CUR

Defined (GEN) and current (CUR) number of read buffers allocated by VTAM to receive data from NCP. The GEN field is either the value initially defined by the MAXBFRU keyword on the VTAM host statement or the value subsequently negotiated between NCP and VTAM. The CUR field is the working value that is either set or limited by the GEN field.

PACING

Cur

Current pacing window size. This value gradually increases until congestion occurs or until the maximum is reached.

Min

Minimum pacing window size. This is always 1.

Max

Maximum pacing window size: MAXBFRU CUR + 1 or 10, whichever is less.

THRESHOLDS

LOW

The minor-congestion threshold is eight times the value of the MAXBFRU keyword on the PU statement.

HIGH

The major-congestion threshold is 16 times the value of the MAXBFRU keyword on the PU statement.

CHANNEL TIMERS

Attention Delay GEN/CUR

Defined (GEN) and current (CUR) maximum interval, in seconds, that NCP delays from the time data is available to the host to the time the attention signal is presented to the channel. GEN is either the value from the NCP generation (the DELAY keyword on the LINE statement) or the value resulting from subsequent NCP processing that overwrote the value from the NCP generation. CUR is the current working value and is either set or limited by GEN.

Attention Timeout GEN/CUR

Defined (GEN) and current (CUR) maximum interval, in seconds, that NCP waits for a response to an attention signal sent to the host before initiating channel discontact. GEN field is either the value from the NCP generation (the TIMEOUT keyword on the LINE statement) or the value resulting from subsequent NCP processing that overwrote the value from the NCP generation. CUR is the current working value that is either set or limited by GEN.

CA Slowdown Limit

Maximum interval, in seconds, that this link can block inbound data before signaling that the station is inoperative, as defined by the CASDL keyword on the PU statement.

PF Keys

F1=HELP

Displays online help for this panel.

F2=IP DETAILS (if the channel has an IP address defined)

Displays the ATUID IP Interface Information Detail panel, as shown on page 4-164, to show details about a specific IP interface.

F3=RETURN

Returns to the previous NTuneMON panel.

F4=VERIFY

Attempts to verify the network ID that you typed in the Network field. NTuneMON will reply with a message that either indicates that the network ID was found or indicates that the network ID is not defined. For more information, see the description of the Network tuning field on page 6-10.

F5=MODIFY

Available after a network ID has been verified. Modifies the SCB control block with the new network ID.

F6=ROLL

Returns to the NetView command line without exiting NTuneMON. To return to NTuneMON from the NetView program, press F6=ROLL or enter **ATUNEMON** on the NetView command line.

F10=HEX

Displays the ATUDP Hexadecimal Storage Display panel, as shown on page 4-68, to show the system status block (SSB).

F11=CHAN IP STATS (if the channel has an IP address defined)

Displays the ATUCI Channel IP Statistics panel, as shown on page 4-36, to show IP statistics for a channel.

F12=REFRESH

Refreshes the information on this panel.

PA1=EXIT

Exits NTuneMON.

PA2=LOG

Saves the information on this panel to the NetView log.

ATUCS 3746-900 Logical Lines Panel

Basic fast-path commands: None

Tuning fields: None

```

ATUCS  A12V7R8      3746-900 Logical Lines      NTuneMON V2R6  13:51
Physical Line Addr= 2176 Name= A12S2176 Type= ESCP Status= ACTIVE
Addr  Type Name      Status  Cur Min Max UNTSZ  MXBFR  SUB.TG/CP
1(01) Link A12LSOC1  ACTIVE
1(01) T5   A12L1S1  XID PEND  1  1  10  N/A  32  TGN=1
2(02) T5   A12L1S2  INACTIVE  1  1  10  N/A  32  TGN=2
3(03) T2.1 A12L1S3  INACTIVE  1  1  10  N/A  32
4(04) T2.1 A12L1S4  INACTIVE  1  1  10  N/A  32
5(05) T2.1 A12L1S5  INACTIVE  1  1  10  N/A  32
6(06) T2.1 A12L1S6  INACTIVE  1  1  10  N/A  32
7(07) T2.1 A12L1S7  INACTIVE  1  1  10  N/A  32
8(08) T2.1 A12L1S8  INACTIVE  1  1  10  N/A  32
9(09) T2.1 A12L1S9  INACTIVE  1  1  10  N/A  32
10(0A) T2.1 A12L1SA  INACTIVE  1  1  10  N/A  32
11(0B) T2.1 A12L1SB  INACTIVE  1  1  10  N/A  32
12(0C) T2.1 A12L1SC  INACTIVE  1  1  10  N/A  32
13(0D) T2.1 A12L1SD  INACTIVE  1  1  10  N/A  32
14(0E) T2.1 A12L1SE  INACTIVE  1  1  10  N/A  32
15(0F) T2.1 A12L1SF  INACTIVE  1  1  10  N/A  32
16(10) T2.1 A12L1S10 INACTIVE  1  1  10  N/A  32
4(04) Link A12LSOC4  INACTIVE
=>
F1=HELP F3=RETURN F6=ROLL F7=BACK F8=FORWARD F10=HEX F12=REFRESH
ENTER-STATION DETAILS PA1=EXIT PA2=LOG

```

Figure 4-15. ATUCS 3746-900 Logical Lines Panel

Description

The ATUCS 3746-900 Logical Lines panel displays detailed information on the logical lines associated with a single ESCON physical line and the PUs defined for the logical line. The PUs for each logical line are displayed immediately below their logical line. This panel is available for NCP V6R2 or later releases. For this panel to be displayed, ESCON lines must be defined in the NCP generation and the 3746 Model 900 must be installed on the communication controller.

To display this panel: On the ATUSC4 3746 Model 900 Adapters panel, as shown on page 4-237, place the cursor under a line address for an ESCP adapter and press Enter.

Fields

NCP name (second field on panel)

Name of the NCP that is currently displayed. You can enter a different NCP name in this field to display information on another NCP.

Physical Line Addr

Line address, as defined by the ADDRESS keyword on the LINE statement.

Name

Name of the ESCON physical line.

Type

Adapter type (ESCP).

Status

Physical line status: ACTIVE or INACTIVE.

The following columns on this panel show information for each logical line and PU:

Addr

Address of the logical line or PU. For logical lines, this is defined by the HOSTLINK keyword on the LINE statement. For PUs, this is defined by the ADDR keyword on the PU statement. This address is displayed in decimal and hexadecimal.

Type

PU type: T1 (type 1), T2.1 (type 2.1), or T5 (type 5). For logical lines, NTuneMON displays Link.

Name

Name of the logical line or PU.

Status

Status of the logical line or PU. For logical lines, the status can be any of the following:

PEND ACTLINK	An activate link command (ACTLINK) is in progress.
ACTIVE	An ACTLINK has been processed, and the line is active.
PEND DACTLNK	A deactivate link command (DACTLINK) is in progress.
INACTIVE	A DACTLINK has been processed, and the line is inactive. Inactive lines are highlighted in reverse-video red.
FORCE DEACT	The line has been forced into deactivation. (A force deactivate command was issued from VTAM.)
PEND ANS	Line quiescence is pending due to automatic network shutdown (ANS).
PEND SWITCH	A switch from primary to secondary is in progress.
OLT TESTING	Online line testing (OLT) is in progress.
WRAP TESTING	Wrap testing is in progress.

For PUs, the status can be any of the following:

INACTIVE	Reset
XID PEND	XID pending with data
XID NODT	XID pending without data
CONT PND	Contact pending
PENDING	Contact and discontact pending
ACTIVE	Active (normal data)
LOAD/DMP	Load/Dump/RPO active
SIM PEND	Set Initialization Mode pending
DISC PND	Discontact pending
LL2 ACT	Link-level 2 active
INOP PND	INOP pending
LL2 PND	Link-level-2 pending
INACT PD	Free-resource operation pending

The following columns on this panel show information for each PU:

Cur

Current pacing window size. This value gradually increases until congestion occurs or until the maximum is reached. This value is used by the internal bidirectional pacing mechanism that controls the flow of PIUs between NCP and the 3746 Model 900 ESCON processor.

Min

Minimum pacing window size. This is always 1. This value is used by the internal bidirectional pacing mechanism that controls the flow of PIUs between NCP and the 3746 Model 900 ESCON processor.

Max

Maximum pacing window size. This value is equal to ([maximum number of host read commands] +1) or 10, whichever is smaller. The maximum number of host read commands is obtained from the XID sent by the host at channel activation time. This value is used by the internal bidirectional pacing mechanism that controls the flow of PIUs between NCP and the 3746 Model 900 ESCON processor.

UNTSZ

Size of the VTAM channel read buffer (IOBUF), as defined by the UNITSZ keyword on the VTAM HOST statement.

MXBFR

Number of read buffers currently allocated by VTAM to receive data from NCP. This value is initially defined by the MAXBFRU keyword on the VTAM HOST statement and is adjusted by negotiation between NCP and VTAM.

SUB.TG/CP

Subarea address and transmission group number, or control point name.

For a type 5 PU, NTuneMON displays the subarea address and transmission group number (in the form *sa.tgn*) if the PU has been contacted and is active. Otherwise, NTuneMON displays only the transmission group number (in the form *TGN=tgn*). The transmission group number is defined by the TGN keyword on the PU statement.

For a type 2.1 PU, NTuneMON displays the control point name if the PU has been contacted and is active; otherwise, this field is blank.

For a type 1 PU, NTuneMON displays N/A.

PF Keys

F1=HELP

Displays online help for this panel.

F3=RETURN

Returns to the previous NTuneMON panel.

F6=ROLL

Returns to the NetView command line without exiting NTuneMON. To return to NTuneMON from the NetView program, press F6=ROLL or enter **ATUNEMON** on the NetView command line.

F7=BACK

Scrolls the panel data backward one screen.

F8=FORWARD

Scrolls the panel data forward one screen.

ATUCS 3746-900 Logical Lines Panel

F10=HEX

Displays the ATUDP Hexadecimal Storage Display panel, as shown on page 4-68, to show the line control block (LKB) for lines or the system status block (SSB) for PUs.

F12=REFRESH

Refreshes the information on this panel.

ENTER=STATION DETAILS

Displays the ATUCL 3746-900 Station Details panel, as shown on page 4-39, to show detailed information on a PU. Place the cursor under the PU you want to view and press Enter. This key has no effect for logical lines.

PA1=EXIT

Exits NTuneMON.

PA2=LOG

Saves the information on this panel to the NetView log.

ATUCX Control Block Pools Extension Panel

Basic fast-path commands: None

Tuning fields: None

ATUCX	A71TEST	Control Block Pools Extension			NTuneMON V2R4	18:32
		Available for each Owner				
Owning Host	ODLC LAN Free	TR LLB Free	FR LLB Free	ODLC FR Free	ISDN PN Free	ISDN SA Free
SMMF	0	0	0	0	0	0
R10N	2	2	2	3	3	2
R01N	2	4	1	2	0	0

=> _
 F1=HELP F3=RETURN F6=ROLL F10=HEX F12=REFRESH PA1=EXIT PA2=LOG

Figure 4-16. ATUCX Control Block Pools Extension Panel

Description

The ATUCX Control Block Pools Extension panel, which is available beginning with NCP V7R6, displays the number of free unreserved resources available for each owning host.

Note: The “Free” counts on the ATUCX panel break down the “FREE UNRSVD” count (on the ATUCB panel) by Owning Host. However, a “Free” count on the ATUCX panel includes only the logical resources that are in a connectable (CONCT) state, while the “FREE UNRSVD” count on the ATUCB panel includes inactive logical resources as well. The owning host is not known until the resource is activated, so the inactive resources cannot be included in this count.

To display this panel: On the ATUCB Control Block Pools/Tables panel, as shown on page 4-17, press F5.

Fields

NCP name (second field on panel)

Name of the NCP that is currently displayed.

Owning Host

The SSCP owner of the listed resources.

Note: SMMF (SSCP Monitor Mode Function) is listed as the first owning host if there are resources that NCP is required to monitor continuously (for example, a channel with MONLINK=CONT specified).

ATUCX Control Block Pools Extension Panel

ODLC LAN Free

The number of ODLC LAN logical resources available to each owning host.

TR LLB Free

The number of NTRI logical resources available to each owning host.

FR LLB Free

The number of base frame frame-relay logical resources available to each owning host.

ODLC FR Free

The number of ODLC frame-relay logical resources available to each owning host.

ISDN PN Free

The number of ISDN logical peripheral resources available to each owning host.

ISDN SA Free

The number of ISDN logical subarea resources available to each owning host.

PF Keys

F1=HELP

Displays online help for this panel.

F3=RETURN

Returns to the previous NTuneMON panel.

F6=ROLL

Returns to the NetView command line without exiting NTuneMON. To return to NTuneMON from the NetView program, press F6=ROLL or enter **ATUNEMON** on the NetView command line.

F10=HEX

Displays the ATUDP Hexadecimal Storage Display panel, as shown on page 4-68, to show the vector table of SNPs (VTS).

F12=REFRESH

Refreshes the information on this panel.

PA1=EXIT

Exits NTuneMON.

PA2=LOG

Saves the information on this panel to the NetView log.

ATUDK ISDN Physical Line Details Panel

Basic fast-path commands: None
 Tuning fields: CIR, MIR, PRE, PER

```

ATUDK  A04C901  ISDN Physical Line Details  NTuneMON V2R5  12:12

OWNERPL Function Active =  NO  Physical Station Details
-----
Physical Line Details
Line Name = A04I2400
Line Address = 2400,Full
Line Status = INACTIVE
Speed = 2048000
Clockng = EXT
Max Frame = 2048
Max DLCI = 0
Data Block = 2048
DYNWIND(nw) = 4
DYNWIND(dw) = 1
DYNWIND(dwc) = 1
ISDN CRC = CRC INCLUDED
ISDN IXF = UDI
LPN = 8037373732303030
LSA = 8000

Station Name = A04P2400
Station Address = 01
Station Status = INACTIVE
Line Timers
TITIMER = 60.0
DDTIMER = 0
T391 = 10
T392 = 15
N391 = 6
N392 = 3
N393 = 4
Local Management Interface
LMI = CCITT
CIR = NO  MIR = -
PRE = -  PER = -

=>
F1=Help  F2=B-Channel  F3=Return  F4=Stations  F5=MODIFY  F6=Roll  F8=DK PG 2
F10=Hex  F12=Refresh  PA1=Exit  PA2=Log
    
```

Figure 4-17. ATUDK ISDN Physical Line Details Panel

Description

The ATUDK ISDN Physical Line Details panel is available starting with NCP V7R5. It displays the physical line details for a selected ISDN line.

To display this panel:

- From the ATUDL ISDN Physical Line Table panel, as shown on page 4-59, place the cursor under a line address and press Enter.
- On the ATUDK2 ISDN Physical Line Details Page 2 panel, as shown on page 4-55, press F7.

Fields

NCP name (second field on panel)

Name of the NCP that is currently displayed.

OWNERPL Function Active (starting with NCP V7R6)

Whether the OWNERPL function is active:

YES The ISDN unassigned logical resources (PHYSRSC=NONE) are being allocated to this physical line based on common SSCP ownership of the physical and logical resources. (This line's resource type, ISDN, was specified on the OWNERPL keyword on the BUILD statement.)

NO The OWNERPL function is not active. (The OWNERPL keyword was not coded on the BUILD statement; or this line's resource type, ISDN, was not specified on the OWNERPL keyword.)

Physical Line Details

Line Name

Name of this line. This name is the label on the LINE statement.

Line Address

Relative line address of the ISDN physical line, and type of port (full or half).

Line Status

Status of the ISDN physical line. This can be any of the following:

- | | |
|---------------------|---|
| PEND ACTLINK | An activate link command (ACTLINK) is in progress. |
| ACTIVE | An ACTLINK has been processed, and the line is active. |
| PEND DACTLNK | A deactivate link command (DACTLINK) is in progress. |
| INACTIVE | A DACTLINK has been processed, and the line is inactive. Inactive lines are highlighted in reverse-video red. |
| FORCE DEACT | The line has been forced into deactivation. (A force deactivate command was issued from VTAM.) |

Speed

Data rate for the line in bits per second, as defined by the *rate* suboperand of the SPEED keyword on the LINE statement. This is the rate at which the devices communicate with the communication controller.

NCP V7R6 and Earlier Releases: The SPEED value displayed on this panel differs from the rate specified for the SPEED keyword. For ISDN physical lines, the value displayed for SPEED is 512000.

Clockng

Whether the modem (data set) or the communication scanner for the line provides the clocking, as defined by CLOCKNG keyword on the LINE statement.

- | | |
|------------|--|
| DIR | The scanner provides clocking and propagates it to the attached DTE. The data signal received by the controller is synchronized with the controller's clock. You must use a directly attached cable. |
| EXT | The modem or other external source provides clocking. You can use either a directly attached cable or a modem cable. |
| INT | The scanner provides clocking but does not propagate it to the attached data terminal equipment (DTE). The scanner synchronizes the received data signal; a different clock is used at each end of a link. You can use either a directly attached cable (no modem) or a modem cable. |

Max Frame

Maximum frame size, in bytes, for this line as defined by the MAXFRAME keyword on the LINE statement.

Max DLCI (starting with NCP V7R6)

Maximum data link connection identifier (DLCI) value, as specified by the MAXDLCI keyword on the ISDN physical GROUP or LINE definition statement.

Data Block

Minimum guaranteed transmission bandwidth (in bytes) that can be allocated to a resource, as defined by the DATABLK keyword on the LINE statement. The DATABLK keyword is used with the *priority* suboperand of the COMRATE keyword on the PU statement to determine a relative priority

among resources. The value of *priority* is multiplied by the value of *DATABLK* to determine the guaranteed minimum number of bytes that a resource can transmit before a different resource must be given a transmit priority.

DYNWIND(nw)

Number of frames that must be received and acknowledged by the adjacent device before the sending NCP increases the IEEE 802.2 LLC working window value. The value in this field is defined by the *nw* suboperand of the *DYNWIND* keyword on the *LINE* or *PU* statement for the physical ISDN line. When the sending NCP receives *nw* consecutive I-frames, the working window value is incremented until it reaches the value specified by *MAXOUT* for subarea connections or the value specified in the VTAM switched major node for peripheral connections. The *nw* value of the physical line applies to all logical peripheral lines and stations associated with that physical line, except any peripheral station for which the *DYNWIND(nw)* value is defined in the VTAM switched major node.

DYNWIND(dw)

Value by which the sending NCP divides, or percentage by which the sending NCP reduces, the IEEE 802.2 LLC working window value when frame loss occurs. 1 is a special value which indicates that the working window value should be set to 1 when frame loss is detected.

The value in this field is defined by the *dw* suboperand of the *DYNWIND* keyword on the *LINE* or *PU* statement for a physical ISDN line. The value applies to all logical peripheral lines and stations associated with that physical line, except any peripheral station for which the *DYNWIND(dw)* value is defined in the VTAM switched major node.

DYNWIND(dwc)

Value by which the sending NCP divides, or percentage by which the sending NCP reduces, the IEEE 802.2 LLC working window value when BECN occurs. 1 is a special value which indicates that the working window value should be set to 1 when BECN is indicated.

The value in this field is defined by the *dwc* suboperand of the *DYNWIND* keyword on the *LINE* or *PU* statement for a physical ISDN line. The value applies to all logical peripheral lines and stations associated with that physical line, except any peripheral station for which the *DYNWIND(dwc)* value is defined in the VTAM switched major node.

ISDN CRC

ISDN channel configuration information: *CRC INCLUDED* or *CRC NOT INCLUDED* to indicate whether CRC is included in frames.

ISDN IXF

ISDN information transfer capability: *UDI* (unrestricted digital information) or *RDI* (restricted digital information).

LPN

Local party number.

LSA

Local party subaddress.

Physical Station Details

ISDN station information:

Station Name

Name defined for this station in the NCP gen. This name is the label on the PU statement.

Station Address

Station address, as defined by the ADDR keyword on the PU statement.

Station Status

Current status of the station. This can be either of the following:

ACTIVE	Active (normal data).
INACTIVE	Reset. Inactive stations are highlighted in reverse-video red.

Line Timers

The NCP generation definitions for the following timer values:

TITIMER

Inactivity Timer (TI) interval, in seconds, that NCP is to wait for a transmitted frame from an adjacent station before sending a poll command. Defined by the TITIMER keyword on the LINE statement for the physical Token-Ring line. The TI value that is specified on the physical line will be used by the logical lines associated with that physical line.

DDTIMER

Delayed disconnect timer, in seconds, as defined by the ISDNDSCT keyword on the GROUP, LINE, or PU statement.

T391

Interval, in seconds, between transmissions of LMI status enquiry messages as defined by the *t391* suboperand of the TIMERS keyword on the PU statement. T391 is used only on the user side of the line.

T392

Interval, in seconds, in which an LMI status enquiry message must be received before the time interval is considered an error interval. Defined by the *t392* suboperand of the TIMERS keyword on the PU statement. T392 is used only on the network side of the line.

N391

Minimum frequency (number of T391 intervals) at which LMI Status Enquiry Full messages are sent over this line to the adjacent node as defined by the SPOLL keyword on the PU statement. This value is displayed only for the user side of the line.

N392 and N393

LMI error threshold at which NCP determines that communication with the adjacent device has been lost, as defined by the ERRORT keyword on the PU statement. This threshold is reached when *N392* LMI errors occur in *N393* consecutive LMI events. For *N392*, NTuneMON shows both the generated value and the current error count.

Local Management Interface

LMI

The LMI standard (CCITT, CCITT-NUI, ANSI, ANSI-NUI, or N/A) as defined by the LMI keyword on the PU statement.

CIR Information (starting with NCP V7R7)

CIR

Whether the Committed Information Rate (CIR) algorithms are used for bandwidth management, as specified by the CIR keyword on the LINE statement.

PRE

An integer used to determine the adaption speed of the CIR adaptive algorithm. Specified by the *precision* parameter of the CIR keyword on the LINE statement.

MIR

An integer used to determine the minimum information rate that the CIR adaptive algorithm can reach for a DLCI. Specified by the *mir%* parameter of the CIR keyword on the LINE statement.

PER

The interval, in seconds, used by the CIR adaptive algorithm to determine the CIR. Specified by the *period* parameter of the CIR keyword on the LINE statement.

PF Keys

F1=Help

Displays online help for this panel.

F2=B-Channel

Displays the ATUDM ISDN B-Channel Line Table panel, as shown on page 4-62, to list the B-channels for the currently displayed ISDN physical line.

F3=Return

Returns to the previous NTuneMON panel.

F4=Stations

Displays the ATUDS ISDN Stations Table List panel, as shown on page 4-71, to list the logical stations that can be attached to the B-channels for the currently displayed ISDN physical line.

F5=MODIFY (starting with NCP V7R7)

Available when the operator has tuning authority and NTuneNCP is included. For more information, refer to Chapter 5, Using the NTuneNCP Tuning Feature.

Updates the NCP tuning parameter with the modified value. If the modification is not valid, the field turns reverse-video pink, and you are prompted to correct the value and resubmit it.

F6=Roll

Returns to the NetView command line without exiting NTuneMON. To return to NTuneMON from the NetView program, press F6=Roll or enter **ATUNEMON** on the NetView command line.

F8=DK Pg 2 (starting with NCP V7R7)

Displays the ATUDK2 ISDN Physical Line Details Page 2 panel, as shown on page 4-55

ATUDK ISDN Physical Line Details Panel

F10=Hex

Displays the ATUDP Hexadecimal Storage Display panel, as shown on page 4-68, to show the line control block (LKB) for the currently displayed ISDN physical line.

F12=Refresh

Refreshes the information on this panel.

PA1=Exit

Exits NTuneMON.

PA2=Log

Saves the information on this panel to the NetView log.

ATUDK2 ISDN Physical Line Details Page 2 Panel

Basic fast-path commands: None

Tuning fields: HLOQSTOP, QSIZEDE, QSIZE, CRATEDLY, DSCRDDL, FRSPRI

```

ATUDK2  A71SUP1  ISDN Physical Line Details Pg2  NTuneMON V2R4  14:22
-----
Line Name   = A71I2368           Station Name = A71P2368
Line Address = 2368,Full         Station Address = 01
Line Status = INACTIVE       Station Status = INACTIVE
DATBLK     = 2048

-----
HLOQSTOP   = 12
QSIZEDE    = 120
QSIZE      = 130
CRATEDLY   = 12
DSCRDDL    = 13
FRSPRI     = 1

=>
F1=Help  F2=B-Channel  F3=Return  F4=Stations  F5=MODIFY  F6=Roll  F7=DK Pg 1
F9=DEFAULT F10=Hex    F12=Refresh  PA1=Exit    PA2=Log

```

Figure 4-18. ATUDK2 ISDN Physical Line Details Page 2 Panel

Description

The ATUDK2 ISDN Physical Line Details Page 2 panel, which is available starting with NCP V7R7, displays detailed information for a single 3746 Model 900 attached ISDN physical line.

To display this panel: On the ATUDK ISDN Physical Line Details panel, as shown on page 4-49, press F8.

Fields

NCP name (second field on panel)

Name of the NCP that is currently displayed.

Line Name

Name of this line. This name is the label on the LINE statement.

Line Address

Address of this line as defined by the ADDRESS keyword on the LINE statement.

Line Status

Physical line status: ACTIVE or INACTIVE.

DATABLK

Minimum guaranteed transmission bandwidth (in bytes) that can be allocated to a protocol, as defined by the DATABLK keyword on the LINE statement. The DATABLK keyword is used with the HLOQSTOP, QSIZEDE, and QSIZE keywords to determine the 3746 Model 900 CLP congestion control parameters.

Station Name

Name defined for this station in the NCP gen. This name is the label on the PU statement.

Station Address

Station address, as defined by the ADDR keyword on the PU statement.

Station Status

Current status of the station. This can be either of the following:

- ACTIVE** Active (normal data).
- INACTIVE** Reset. Inactive stations are highlighted in reverse-video red.

HLOQSTOP

The threshold that determines the maximum number of bytes that can be queued to the 3746 Model 900 attached ISDN physical line's hardware queue before a 3746 Model 900 software queue is created for the physical line. Defined by the HLOQSTOP keyword on the LINE statement. The value displayed in this field is multiplied by the DATABLK value to determine the threshold in bytes.

If this field displays DEFAULT, then the value for this field is provided by the 3746 Model 900.

QSIZEDE

The 3746 Model 900 software queue threshold which, when it is reached, triggers the discarding of the last frames received with the Discard Eligible (DE) indicator set to binary 1. Defined by the QSIZEDE keyword on the LINE statement. The value displayed in this field is multiplied by the DATABLK value to determine the threshold in bytes.

If this field displays DEFAULT, then the value for this field is provided by the 3746 Model 900.

QSIZE

The 3746 Model 900 software queue threshold which, when it is reached, triggers the discarding of all the last frames received regardless of how the Discard Eligible (DE) indicator is set. Defined by the QSIZE keyword on the LINE statement. The value displayed in this field is multiplied by the DATABLK value to determine the threshold in bytes.

If this field displays DEFAULT, then the value for this field is provided by the 3746 Model 900.

CRATEDLY

A threshold for a minimum time on the 3746 Model 900 software queue, used by the 3746 in conjunction with the DSCRDDL and COMRATE values to trigger congestion controls (discarding of the frame or setting of the FECN indicator) under certain conditions.

If the frame has been on the software queue in excess of the amount of time specified by CRATEDLY but less than the amount of time specified by DSCRDDL, then the following action will be taken:

- If more than 100% of the station's COMRATE has been used, then the frame will be discarded.
- If more than 75% but less than or equal to 100% of the station's COMRATE has been used, then the frame will be transmitted with the FECN indicator set to binary 1.

- If less than 75% of the station's COMRATE has been used, then the frame will be transmitted.

The value in this field is defined by the CRATEDLY keyword on the LINE statement.

If this field displays DEFAULT, then the value for this field is provided by the 3746 Model 900.

DSCRDDL

A threshold for a maximum time on the 3746 Model 900 software queue, used by the 3746 in conjunction with the CRATEDLY and COMRATE values to trigger congestion controls (discarding of the frame or setting of the FECN indicator) under certain conditions. Defined by the DSCRDDL keyword on the LINE statement.

If this field displays DEFAULT, then the value for this field is provided by the 3746 Model 900.

FRSPRI

A relative service priority at a station level, as defined by the FRSPRI keyword on the LINE statement.

PF Keys

F1=Help

Displays online help for this panel.

F2=B-Channel

Displays the ATUDM ISDN B-Channel Line Table panel, as shown on page 4-62, to list the B-channels for the currently displayed ISDN physical line.

F3=Return

Returns to the previous NTuneMON panel.

F4=Stations

Displays the ATUDS ISDN Stations Table List panel, as shown on page 4-71, to list the logical stations that can be attached to the B-channels for the currently displayed ISDN physical line.

F5=MODIFY

Available when the operator has tuning authority and NTuneNCP is included. For more information, refer to Chapter 5, Using the NTuneNCP Tuning Feature.

Updates the NCP tuning parameter with the modified value. If the modification is not valid, the field turns reverse-video pink, and you are prompted to correct the value and resubmit it.

F6=Roll

Returns to the NetView command line without exiting NTuneMON. To return to NTuneMON from the NetView program, press F6=ROLL or enter **ATUNEMON** on the NetView command line.

F7=DK Pg 1

Scrolls back to the ATUDK ISDN Physical Line Details panel, as shown on page 4-49.

F9=DEFAULT

Resets the HLOQSTOP, QSIZEDE, QSIZE, CRATEDLY, and DSCRDDLY fields to DEFAULT, which means that future values for these fields will be provided by the 3746 Model 900.

F10=Hex

Displays the ATUDP Hexadecimal Storage Display panel, as shown on page 4-68, to show the line control block (LKB) for the currently displayed ISDN physical line.

F12=Refresh

Refreshes the information on this panel.

PA1=Exit

Exits NTuneMON.

PA2=Log

Saves the information on this panel to the NetView log.

ATUDL ISDN Physical Line Table Panel

Basic fast-path commands: DL, ISDN

Tuning fields: None

ATUDL			A04ISDX			ISDN Physical Line Table			NTuneMON V2R3			13:22		
CCU = 15						Buffers = 2								
ADDR	NAME	Status	ADDR	NAME	Status									
2272	A04I2272	ACTIVE	2336	A04I2336	INACTIVE									

=>
 F1=Help F2=B-Channel F3=Return F4=Stations F6=Roll F7=Back F8=FWD
 ENTER=Physical Line Detail F10=Hex F12=Refresh PA1=Exit PA2=Log

Figure 4-19. ATUDL ISDN Physical Line Table Panel

Description

The ATUDL ISDN Physical Line Table panel is available starting with NCP V7R5. It lists all defined ISDN physical lines for the selected NCP.

To display this panel:

- From PF key selection number 4 on the ATUNP NCP Selection panel, as shown on page 4-204, press F4.
- From PF key selection number 4 on the ATUNW NCP Wide Selection panel, as shown on page 4-212, press F4.
- From PF key selection number 4 on the ATUCD CDS NCP Selection panel, as shown on page 4-27, press F4.
- From the ATUFP Frame Relay Physical Line Details Page 1 panel, as shown on page 4-108, if ISDN BACKUP ALLOWED is displayed, press F9.

Fields

NCP name (second field on panel)

Name of the NCP that is currently displayed.

CCU

NCP cycle utilization percentage.

Buffers

Percentage of NCP buffers in use. This figure equals (number of buffers currently in use) / (total number of buffers) * 100. The total number of buffers depends on the amount of NCP storage (the MEMSIZE keyword on the

ATUDL ISDN Physical Line Table Panel

BUILD statement), the NCP load module size, and the NCP buffer size (the BFRS keyword on the BUILD statement).

ADDR

Relative line address of this physical line. Defined by the ADDRESS keyword on the LINE statement.

NAME

Name of this line. This name is the label on the LINE statement.

Status

Current status of the ISDN physical line. This is one of:

PEND ACTLINK An activate link command (ACTLINK) is in progress.

ACTIVE An ACTLINK has been processed, and the line is active.

PEND DACTLNK A deactivate link command (DACTLINK) is in progress.

INACTIVE A DACTLINK has been processed, and the line is inactive. Inactive lines are highlighted in reverse-video red.

FORCE DEACT The line has been forced into deactivation. (A force deactivate command was issued from VTAM.)

PF Keys

F1=Help

Displays online help for this panel.

F2=B-Channel

Displays the ATUDM ISDN B-Channel Line Table panel, as shown on page 4-62, to list the B-channels for a selected ISDN physical line. Place the cursor under a line address and press F2.

F3=Return

Returns to the previous NTuneMON panel.

F4=Stations

Displays the ATUDS ISDN Stations Table List panel, as shown on page 4-71, to list the logical stations that can be attached to the B-channels for a selected ISDN physical line. Place the cursor under a line address and press F2.

F6=Roll

Returns to the NetView command line without exiting NTuneMON. To return to NTuneMON from the NetView program, press F6=Roll or enter **ATUNEMON** on the NetView command line.

F7=Back

Scrolls the panel data backward one screen.

F8=FWD

Scrolls the panel data forward one screen.

F10=Hex

Displays the ATUDP Hexadecimal Storage Display panel, as shown on page 4-68, to show the line control block (LKB) for a selected ISDN line. Place the cursor under a line address and press Enter. If the cursor is not under a line address, NTuneMON displays the ISDN physical line table (IPT) control block.

F12=Refresh

Refreshes the information on this panel.

ENTER=Physical Line Detail

Displays the ATUDK ISDN Physical Line Details panel, as shown on page 4-49, for a selected ISDN line. Place the cursor under a line address and press Enter.

PA1=Exit

Exits NTuneMON.

PA2=Log

Saves the information on this panel to the NetView log.

ATUDM ISDN B-Channel Line Table Panel

Basic fast-path commands: None
 Tuning fields: None

```

ATUDM  A04ISDX  ISDN B-Channel Line Table  NTuneMON V2R3  13:34

Physical Line Name = A04I2272  Address = 2272  Status = ACTIVE

ADDR  NAME  Status  |  ADDR  NAME  Status
2273  A04I2273  ACTIVE  |  2274  A04I2274  ACTIVE
2275  A04I2275  ACTIVE  |  2276  A04I2276  ACTIVE
2277  A04I2277  ACTIVE  |  2278  A04I2278  ACTIVE
2279  A04I2279  ACTIVE  |  2280  A04I2280  ACTIVE
2281  A04I2281  ACTIVE  |  2282  A04I2282  ACTIVE
2283  A04I2283  ACTIVE  |  2284  A04I2284  ACTIVE
2285  A04I2285  ACTIVE  |  2286  A04I2286  ACTIVE
2287  A04I2287  ACTIVE  |  2288  A04I2288  ACTIVE
2289  A04I2289  ACTIVE  |  2290  A04I2290  ACTIVE
2291  A04I2291  ACTIVE  |  2292  A04I2292  ACTIVE
2293  A04I2293  ACTIVE  |  2294  A04I2294  ACTIVE
2295  A04I2295  ACTIVE  |  2296  A04I2296  ACTIVE
2297  A04I2297  ACTIVE  |  2298  A04I2298  ACTIVE
2299  A04I2299  ACTIVE  |  2300  A04I2300  ACTIVE
2301  A04I2301  ACTIVE  |  2302  A04I2302  ACTIVE

=>
F1=Help  F3=Return  F4=Stations  F6=Roll  F7=Back  F8=FWD  F10=Hex
ENTER=B-Channel Details  F12=Refresh  PA1=Exit  PA2=Log
    
```

Figure 4-20. ATUDM ISDN B-Channel Line Table Panel

Description

The ATUDM ISDN B-Channel Line Table panel is available starting with NCP V7R5. It lists the B-channels for a selected ISDN physical line.

To display this panel:

- From the ATUDL ISDN Physical Line Table panel, as shown on page 4-59, place the cursor under a line address and press F2.
- From the ATUDK ISDN Physical Line Details panel, as shown on page 4-49, press F2.
- From the ATUDK2 ISDN Physical Line Details Page 2 panel, as shown on page 4-55, press F2.

Fields

NCP name (second field on panel)

Name of the NCP that is currently displayed.

ISDN Physical Line

Physical Line Name

Name of this line. This name is the label on the LINE statement.

Address

Address of the port. Defined by the ADDRESS keyword on the LINE statement.

Status

Current status of the ISDN physical line. This is one of:

PEND ACTLINK	An activate link command (ACTLINK) is in progress.
ACTIVE	An ACTLINK has been processed, and the line is active.
PEND DACTLNK	A deactivate link command (DACTLINK) is in progress.
INACTIVE	A DACTLINK has been processed, and the line is inactive. Inactive lines are highlighted in reverse-video red.
FORCE DEACT	The line has been forced into deactivation. (A force deactivate command was issued from VTAM.)

B-Channel List

ADDR

Address of the B-channel. Defined by the ADDRESS keyword on the LINE statement.

NAME

Name of the B-channel as defined in the NCP gen. This name is the label on the LINE statement.

Status

Status of the B-channel. This can be one of:

PEND ACTLINK	An activate link command (ACTLINK) is in progress.
ACTIVE	An ACTLINK has been processed, and the line is active.
PEND DACTLNK	A deactivate link command (DACTLINK) is in progress.
PEND FORCE	The link has been forced into deactivation, which is in progress.
INACTIVE	A DACTLINK has been processed, and the line is inactive. Inactive lines are highlighted in reverse-video red.
FORCE DEACT	The line has been forced into deactivation. (A force deactivate command was issued from VTAM.)

PF Keys

F1=Help

Displays online help for this panel.

F3=Return

Returns to the previous NTuneMON panel.

F4=Stations

Displays the ATUDS ISDN Stations Table List panel, as shown on page 4-71, to list the logical stations that can be attached to the B-channels for the currently displayed ISDN physical line.

F6=Roll

Returns to the NetView command line without exiting NTuneMON. To return to NTuneMON from the NetView program, press F6=Roll or enter **ATUNEMON** on the NetView command line.

F7=Back

Scrolls the panel data backward one screen.

ATUDM ISDN B-Channel Line Table Panel

F8=FWD

Scrolls the panel data forward one screen.

F10=Hex

Displays the ATUDP Hexadecimal Storage Display panel, as shown on page 4-68, to show the line control block (LKB) for a selected ISDN line. Place the cursor under a line address and press Enter. If the cursor is not under a line address, NTuneMON displays the ISDN B-channel line table (IBT) control block.

F12=Refresh

Refreshes the information on this panel.

Enter=B-Channel Details

Displays the ATUDN ISDN B-Channel Line Details panel, as shown on page 4-65, for a selected B-channel. Place the cursor under a B-channel address and press Enter.

PA1=Exit

Exits NTuneMON.

PA2=Log

Saves the information on this panel to the NetView log.

ATUDN ISDN B-Channel Line Details Panel

Basic fast-path commands: None

Tuning fields: None

```

ATUDN  A04ISDX  ISDN B-Channel Line Details  NTuneMON V2R3  08:29

  ISDN Physical Line  B-Channel Line Details
  Line Name = A04I2272  B-Channel Name = A04I2273
  Line Address = 2272  B-Channel Addr = 2273
  Line Status = ACTIVE  Status = ACTIVE
                          LPN = 8037373732303030
                          LSA = 8000
                          RPN = 0037373731303030
                          RSA = 8031
                          ISDN IXF = UDI

  B-Channel Station Details
  Station Name = A04P2273
  Station Addr = D9
  Status = ACTIVE

  Local Management Interface
  LMI = ANSI

=>
F1=Help F3=Return F4=Stations F6=Roll F10=Hex F12=Rfsh PA1=Exit PA2=LOG

```

Figure 4-21. ATUDN ISDN B-Channel Line Details Panel

Description

The ATUDN ISDN B-Channel Line Details panel is available starting with NCP V7R5. It displays detailed information on a selected ISDN B-channel.

To display this panel:

- From the ATUDM ISDN B-Channel Line Table panel, as shown on page 4-62, place the cursor under a B-channel address and press Enter.
- From the ATUDT ISDN Station Details panel, as shown on page 4-73, press Enter.

Fields

NCP name (second field on panel)

Name of the NCP that is currently displayed.

ISDN Physical Link

Line Name

Name of the physical line associated with the B-channel. This name is the label on the LINE statement.

Line Address

Relative line address of the associated physical line. Defined by the ADDRESS keyword on the LINE statement.

Line Status

Status of the associated physical line. This is one of:

PEND ACTLINK An activate link command (ACTLINK) is in progress.

ATUDN ISDN B-Channel Line Details Panel

ACTIVE	An ACTLINK has been processed, and the line is active.
PEND DACTLNK	A deactivate link command (DACTLINK) is in progress.
INACTIVE	A DACTLINK has been processed, and the line is inactive. Inactive lines are highlighted in reverse-video red.
FORCE DEACT	The line has been forced into deactivation. (A force deactivate command was issued from VTAM.)

B-Channel Line Details

B-Channel Name

Name of the B-channel. This name is the label on the LINE statement.

B-Channel Addr

Address of the B-channel. Defined by the ADDRESS keyword on the LINE statement.

Status

Status of the B-channel. This is one of:

PEND ACTLINK	An activate link command (ACTLINK) is in progress.
ACTIVE	An ACTLINK has been processed, and the line is active.
PEND DACTLNK	A deactivate link command (DACTLINK) is in progress.
INACTIVE	A DACTLINK has been processed, and the line is inactive. Inactive lines are highlighted in reverse-video red.
FORCE DEACT	The line has been forced into deactivation. (A force deactivate command was issued from VTAM.)

LPN

Local party number.

LSA

Local party subaddress.

RPN

Remote party number.

RSA

Remote party subaddress.

ISDN IXF

ISDN information transfer capability:

UDI

Unrestricted digital information

RDI

Restricted digital information

B-Channel Station Details

Station Name

Name defined in the NCP for this station. This name is the label on the PU statement.

Station Addr

Address of the station, as defined by the ADDR keyword on the PU statement.

Status

Current status of the station. This can be either of the following:

ACTIVE	Active (normal data)
INACTIVE	Reset

Local Management Interface

LMI

The LMI standard (CCITT, CCITT-NUI, ANSI, ANSI-NUI, or N/A) as defined by the LMI keyword on the PU statement.

PF Keys

F1=Help

Displays online help for this panel.

F3=Return

Returns to the previous NTuneMON panel.

F4=Stations

Displays the ATUDS ISDN Stations Table List panel, as shown on page 4-71, to list the logical stations that can be attached to the currently displayed B-channel.

F6=Roll

Returns to the NetView command line without exiting NTuneMON. To return to NTuneMON from the NetView program, press F6=Roll or enter **ATUNEMON** on the NetView command line.

F10=Hex

Displays the ATUDP Hexadecimal Storage Display panel, as shown on page 4-68, to show the ISDN B-channel control block (IBB).

F12=Rfsh

Refreshes the information on this panel.

PA1=Exit

Exits NTuneMON.

PA2=Log

Saves the information on this panel to the NetView log.

ATUDP Hexadecimal Storage Display Panel

Basic fast-path commands: DP, HEX

Tuning fields: None

```

ATUDP A04NT02 Hexadecimal Storage Display NTuneMON V2R1 08:22
Display Address= 169800 History CB
169800 D7F5C4D7 C01D3E40 40050000 20000000 *P5DP... * 169800 NTR XDA
169810 00000000 00000000 00000000 00000000 *.....* XDB
169820 D7C4D4E3 C01D3E40 40050000 10000000 *PDMT... * XDH
169830 00000000 00000000 00000000 00000000 *.....* HWX
169840 D4C4D4E3 C01D3BC0 10102000 00000000 *MDMT.....* HWE
169850 00000000 00000000 00000000 00000000 *.....* RVT
169860 D4D3F3F1 C01D3BC0 101D5C38 10000000 *ML31.....* DTG
169870 40CB0000 00000000 00000000 00000000 *.....* NNT
169880 D7F5C4D7 F61D3E40 40050000 20000000 *P5DP6.. * PSB
169890 00000000 00000000 00000000 00000000 *.....* PSI
1698A0 D7C4D4E3 F61D3E40 40050000 10000000 *PDMT6.. * QAB
1698B0 00000000 00000000 00000000 00000000 *.....* AIT
1698C0 D4C4D4E3 F61D3BC0 10102000 00000000 *MDMT6.....* FAX
1698D0 00000000 00000000 00000000 00000000 *.....* AVB
1698E0 D4D3F3F1 F61D3BC0 101D5C48 10000000 *ML316.....* IPS
1698F0 40CB0000 00000000 00000000 00000000 *.....* IPC
169900 D3E3D640 811D87A0 E01D3E40 24000000 *LTO a.g... * NRP
169910 40050000 00000000 00000000 00000000 *.....* RIB
169920 D3E7E2C3 811D87A0 E0000000 04000000 *LXSCa.g... *
169930 80000000 00000000 00000000 00000000 *.....*
=>
F1=HELP F3=RTN F6=ROLL F7=BACK F8=FORWARD ENTER=FOLLOW PTR F12=RFRSH PA2=LOG
    
```

Figure 4-22. ATUDP Hexadecimal Storage Display Panel

Description

The ATUDP Hexadecimal Storage Display panel displays 320 bytes at a time of NCP storage in hexadecimal and EBCDIC formats.

To display this panel, press F10 from most NTuneMON panels.

The address range of the storage displayed on this panel is determined when you enter the panel; for example, when you enter this panel from the ATUVR Virtual Route panel or ATUTG Transmission Group panel, this panel displays the VRB or TGB for the virtual route or transmission group under which you placed the cursor.

The data on this panel is refreshed whenever you press Enter or a PF or PA key.

Fields

NCP name (second field on panel)

Name of the NCP that is currently displayed. You can enter a different NCP name in this field to display storage for another NCP. This field accepts input only if the previously displayed panel allowed the NCP name field to be changed. The History column is changed to show address and control blocks for the NCP currently listed in the NCP name field.

Display Address

The starting address of the storage currently displayed. To display storage starting at a different address, type the new address in this field or place the cursor under an address in the first column and press the Enter key.

NCP storage

The first column displays the last 3 bytes of the starting address of each 16-byte section of storage. The remaining columns on this panel display NCP storage in hexadecimal and EBCDIC formats.

History

A list of all the control blocks and addresses you have displayed. To redisplay any control block or address listed in this column, place the cursor under the control block name or address and press Enter.

CB

A list of the major NCP control blocks. To display any control block listed here, place the cursor under the control block name and press Enter.

PF Keys

F1=HELP

Displays online help for this panel.

F3=RTN

Returns to the previous NTuneMON panel.

F6=ROLL

Returns to the NetView command line without exiting NTuneMON. To return to NTuneMON from the NetView program, press F6=ROLL or enter **ATUNEMON** on the NetView command line.

F7=BACK

If the cursor is under an address in the leftmost column in the storage display, scrolls the storage display backward so that the address is at the bottom of the screen.

If the cursor is in a hexadecimal word in the storage display, scrolls the storage display backward so that the word is the last word displayed on the screen.

If the cursor is in the control block list, scrolls the control block list backward one screen.

F8=FORWARD

If the cursor is under an address in the leftmost column in the storage display, scrolls the storage display forward so that the address is at the top of the screen.

If the cursor is in a hexadecimal word in the storage display, scrolls the storage display forward so that the word is the first word displayed on the screen.

If the cursor is in the control block list, scrolls the control block list forward one screen.

ATUDP Hexadecimal Storage Display Panel

ENTER=FOLLOW PTR

Displays a different section of NCP storage, as follows:

If the cursor is under an address in the storage display or the History column, displays NCP storage starting at that address. This is a convenient way to follow a chain of pointers.

If the cursor is under a control block name in the History or CB column, displays that control block.

F12=RFRSH

Refreshes the storage data displayed on the panel. Any other action on this panel also refreshes the data.

PA1=EXIT

Exits NTuneMON.

PA2=LOG

Saves the information on this panel to the NetView log.

ATUDS ISDN Stations Table List Panel

Basic fast-path commands: None

Tuning fields: None

ATUDS		A04C901		ISDN Stations Table List		NTuneMON V2R5		12:37	
ADDR	NAME	Status	ADDR	NAME	Status	ADDR	NAME	Status	ADDR
N/A	A04IBP01	INACTIVE	N/A	A04IBP02	INACTIVE	N/A	A04IBP03	INACTIVE	N/A
N/A	A04IBP03	INACTIVE	N/A	A04IBP04	INACTIVE	N/A	A04IBP05	INACTIVE	N/A
N/A	A04IBP05	INACTIVE	N/A	A04IBP06	INACTIVE	N/A	A04IBP07	INACTIVE	N/A
N/A	A04IBP07	INACTIVE	N/A	A04IBP08	INACTIVE	N/A	A04IBP09	INACTIVE	N/A
N/A	A04IBP09	INACTIVE	N/A	A04IBP10	INACTIVE	N/A	A04IBP11	INACTIVE	N/A
N/A	A04IBP11	INACTIVE	N/A	A04IBP12	INACTIVE	N/A	A04IBP13	INACTIVE	N/A
N/A	A04IBP13	INACTIVE	N/A	A04IBP14	INACTIVE	N/A	A04IBP15	INACTIVE	N/A
N/A	A04IBP15	INACTIVE	N/A	A04IBP16	INACTIVE	N/A	A04IBP17	INACTIVE	N/A
N/A	A04IBP17	INACTIVE	N/A	A04IBP18	INACTIVE	N/A	A04IBP19	INACTIVE	N/A
N/A	A04IBP19	INACTIVE	N/A	A04IBP20	INACTIVE	N/A	A04IBP21	INACTIVE	N/A
N/A	A04IBP21	INACTIVE	N/A	A04IBP22	INACTIVE	N/A	A04IBP23	INACTIVE	N/A
N/A	A04IBP23	INACTIVE	N/A	A04IBP24	INACTIVE	N/A	A04IBP25	INACTIVE	N/A
N/A	A04IBP25	INACTIVE	N/A	A04IBP26	INACTIVE	N/A	A04IBP27	INACTIVE	N/A
N/A	A04IBP27	INACTIVE	N/A	A04IBP28	INACTIVE	N/A	A04IBP29	INACTIVE	N/A
N/A	A04IBP29	INACTIVE	N/A	A04IBP30	INACTIVE	N/A			

=>
 F1=Help F3=Return F6=Roll F7=Back F8=FWD F10=Hex
 ENTER=Station Details F12=Refresh PA1=Exit PA2=Log

Figure 4-23. ATUDS ISDN Stations Table List Panel

Description

The ATUDS ISDN Stations Table List panel is available starting with NCP V7R5. It lists the logical stations that can be attached to the B-channels of an ISDN physical line.

To display this panel:

- From the ATUDL ISDN Physical Line Table panel, as shown on page 4-59, place the cursor under a line address and press F4.
- From the ATUDK ISDN Physical Line Details panel, as shown on page 4-49, press F4.
- From the ATUDK2 ISDN Physical Line Details Page 2 panel, as shown on page 4-55, press F4.
- From the ATUDM ISDN B-Channel Line Table panel, as shown on page 4-62, press F4.
- From the ATUDN ISDN B-Channel Line Details panel, as shown on page 4-65, press F4.

Fields

NCP name (second field on panel)

Name of the NCP that is currently displayed.

ADDR

BAN identifier as defined by the LOCADD keyword on the ISDN physical LINE statement.

ATUDS ISDN Stations Table List Panel

NAME

Name of the station, as defined by the label on the PU statement. The name of a subarea station is displayed in blue; the name of a peripheral station is displayed in turquoise.

Status

Current status of the ISDN logical line. This is either of the following:

ACTIVE	Active (normal data).
INACTIVE	Reset. Inactive stations are highlighted in reverse-video red.

PF Keys

F1=Help

Displays online help for this panel.

F3=Return

Returns to the previous NTuneMON panel.

F6=Roll

Returns to the NetView command line without exiting NTuneMON. To return to NTuneMON from the NetView program, press F6=Roll or enter **ATUNEMON** on the NetView command line.

F7=Back

Scrolls the panel data backward one screen.

F8=FWD

Scrolls the panel data forward one screen.

F10=Hex

Displays the ATUDP Hexadecimal Storage Display panel, as shown on page 4-68, to show the ISDN logical station control block (ISB) for a selected ISDN line. Place the cursor under a line address and press Enter. If the cursor is not under a line address, NTuneMON displays the ISDN logical station table (IST) control block.

F12=Refresh

Refreshes the information on this panel.

Enter=Station Details

Displays the ATUDT ISDN Station Details panel, as shown on page 4-73, for a selected ISDN station. Place the cursor under a station address and press Enter.

PA1=Exit

Exits NTuneMON.

PA2=Log

Saves the information on this panel to the NetView log.

ATUDT ISDN Station Details Panel

Basic fast-path commands: None
 Tuning fields: Station PRI, PIUCHECK Gen

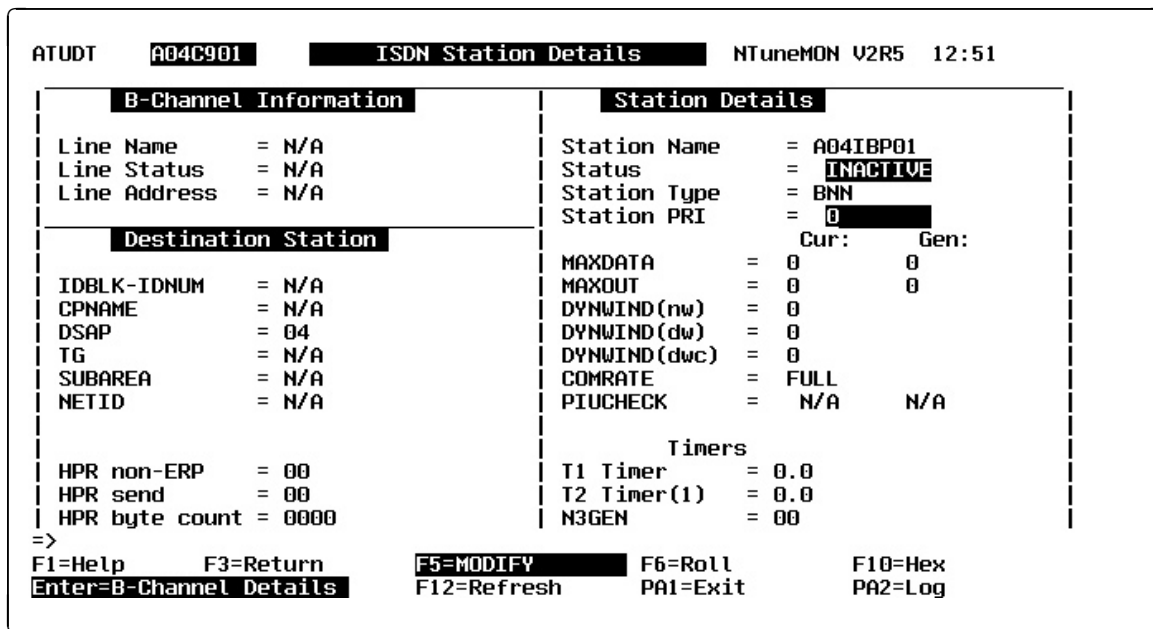

Figure 4-24. ATUDT ISDN Station Details Panel

Description

The ATUDT ISDN Station Details panel is available starting with NCP V7R5. It displays detailed information on a selected ISDN logical station along with information on the assigned B-channel.

To display this panel: On the ATUDS ISDN Stations Table List panel, as shown on page 4-71, place the cursor under a station address and press Enter.

Fields

NCP name (second field on panel)

Name of the NCP that is currently displayed.

B-Channel Information

This information is current if the station is active, residual if the station was previously active, or "N/A" if the station has not been active.

Line Name

Line name of the B-channel that this station is or has been attached to. This name is the label on the LINE statement.

Line Status

Status of the B-channel. This is one of:

- PEND ACTLINK** An activate link command (ACTLINK) is in progress.
- ACTIVE** An ACTLINK has been processed, and the line is active.
- PEND DACTLNK** A deactivate link command (DACTLINK) is in progress.

ATUDT ISDN Station Details Panel

INACTIVE	A DACTLINK has been processed, and the line is inactive. Inactive lines are highlighted in reverse-video red.
FORCE DEACT	The line has been forced into deactivation. (A force deactivate command was issued from VTAM.)

Line Address

Address of the B-channel. Defined by the ADDRESS keyword on the LINE statement.

Destination Station

IDBLK-IDNUM

Device type and identification number, as defined on the VTAM switched major node. IDBLK is up to 3 hexadecimal characters; IDNUM is up to 5 hexadecimal characters.

CPNAME

For an active type 2.1 PU, NTuneMON displays the control point name. Otherwise, NTuneMON displays N/A.

DSAP

Destination service access point, part of the address field of LLC frames. The DSAP is the first byte of the address defined by the ADDR keyword on the PU statement.

TG

Transmission group number as defined by TGN on the PU statement.

SUBAREA

Address of the destination subarea.

NETID

For subarea stations, network identifier (NETID) of the adjacent NCP. For peripheral stations, NETID of the station at the other end of the link.

HPR non-ERP

HPR non-ERP outbound frame count—the number of HPR non-ERP frames transmitted.

HPR send

HPR send-frame count—the number of HPR frames transmitted.

HPR byte count

Total number of HPR bytes transmitted.

Station Details

Station Name

Name of the station as defined by the label on the PU statement.

Status

Current status of the station. This is either of the following:

ACTIVE	Active (normal data).
INACTIVE	Reset. Inactive stations are highlighted in reverse-video red.

Station Type

SUBAREA or PERIPHERAL.

Station PRI (starting with NCP V7R7)

A relative service priority, at a station level, for the displayed ISDN station. Defined by the FRSPRI keyword on the PU statement.

MAXDATA Cur

Current maximum inbound frame size for the destination station. This field is a working value that is either set or limited by the MAXDATA Gen field.

MAXDATA Gen

Generated maximum inbound frame size for the destination station. Gen is either the value from the NCP generation (MAXDATA keyword on the PU statement) or the value resulting from subsequent NCP processing that overwrote the generated value.

MAXOUT Cur (not available for 3746 Model 900)

Current maximum number of frames for the destination station as negotiated between the end points. It is used to set the initial value for the WW (working window) field, which appears (for example) on the ATUFT2 Frame Relay Terminating Equipment Details Page 2 panel, on page 4-143. This field is a working value that is either set or limited by the MAXDATA Gen field.

MAXOUT Gen

Generated maximum number of frames for the destination station. Gen is either the value from the NCP generation (MAXOUT keyword on the PU statement) or the value resulting from subsequent NCP processing that overwrote the generated value. MAXOUT Gen is used to negotiate MAXOUT Cur.

DYNWIND(nw)

Number of frames that must be received and acknowledged by the adjacent device before the sending NCP increases the IEEE 802.2 LLC working window value. Defined by the *nw* suboperand of the DYNWIND keyword on the LINE or PU statement for the physical line. When the sending NCP receives *nw* consecutive I-frames, the working window value is incremented until it reaches the value specified by MAXOUT for subarea connections or the value specified in the VTAM switched major node for peripheral connections.

The *nw* value of the physical line applies to all logical peripheral lines and stations associated with that physical line, except any peripheral station for which the DYNWIND(*nw*) value is defined in the VTAM switched major node.

DYNWIND(dw)

Value by which the sending NCP divides, or percentage by which the sending NCP reduces, the IEEE 802.2 LLC working window value when frame loss occurs. 1 is a special value which indicates that the working window value should be set to 1 when frame loss is detected.

The value in this field is defined by the *dw* suboperand of the DYNWIND keyword on the LINE or PU statement for a physical ISDN line. The value applies to all logical peripheral lines and stations associated with that physical line, except any peripheral station for which the DYNWIND(*dw*) value is defined in the VTAM switched major node.

DYNWIND(dwc)

Value by which the sending NCP divides, or percentage by which the sending NCP reduces, the IEEE 802.2 LLC working window value when BECN occurs. 1 is a special value which indicates that the working window value should be set to 1 when BECN is indicated.

The value in this field is defined by the *dwc* suboperand of the DYNWIND keyword on the LINE or PU statement for a physical ISDN line. The value applies to all logical peripheral lines and stations associated with that physical

line, except any peripheral station for which the DYNWIND(dwc) value is defined in the VTAM switched major node.

COMRATE

Status of the discard-eligible (DE) indicator for this TESP as defined by the FULL|NONE suboperand of the COMRATE keyword on the LINE statement. FULL indicates that frames sent by this TESP are not discard-eligible. NONE indicates that all frames sent by this TESP are discard-eligible except for the following types:

- S frames (RR, RNR, and REJ), including RRs piggybacked on I-frames
- Network priority frames (virtual route pacing and TG sweep)
- XIDs

Discard-eligible frames are discarded before non-discard-eligible frames to relieve severe network congestion.

PIUCHECK Cur (starting with NCP V7R7; subarea stations only)

Current YES or NO value indicating whether a checksum validation is performed on PIUs sent from and received by this station. This field is a working value that is either set or limited by the PIUCHECK Gen field for this station and the adjacent link station.

PIUCHECK Gen (starting with NCP V7R7; subarea stations only)

Generated YES or NO value indicating whether a checksum validation is performed on PIUs sent from and received by this station. This field, unless tuned, is the value from the NCP generation (PIUCHECK keyword on the PU statement).

Timers

T1 Timer

Reply timer (T1) value for stations connected to a frame-relay network as defined by the LOCALTO keyword on the LINE statement or the *localt1* suboperand of the T1TIMER keyword on the LINE statement.

T2 Timer

Acknowledgement timer (T2) value as defined by the *localt2* suboperand of the T2TIMER keyword on the LINE statement.

N3GEN

Generated maximum number of I-frames received before sending an acknowledgement. Defined by the *n3* suboperand of the T2TIMER keyword on the LINE statement.

PF Keys

F1=Help

Displays online help for this panel.

F3=Return

Returns to the previous NTuneMON panel.

F5=MODIFY (starting with NCP V7R7)

Available when the operator has tuning authority and NTuneNCP is included. For more information, refer to Chapter 5, Using the NTuneNCP Tuning Feature.

Updates the NCP tuning parameter with the modified value. If the modification is not valid, the field turns reverse-video pink, and you are prompted to correct the value and resubmit it.

F6=Roll

Returns to the NetView command line without exiting NTuneMON. To return to NTuneMON from the NetView program, press F6=Roll again or enter **ATUNEMON** on the NetView command line.

F10=Hex

Displays the ATUDP Hexadecimal Storage Display panel, as shown on page 4-68, to show the ISDN station control block (ISB) for the currently displayed ISDN line.

F12=Refresh

Refreshes the information on this panel.

Enter=B-Channel Details

Displays the ATUDN ISDN B-Channel Line Details panel, as shown on page 4-65, for the currently selected B-channel, if that channel is active.

PA1=Exit

Exits NTuneMON.

PA2=Log

Saves the information on this panel to the NetView log.

ATUED PEP Line Details Panel

Basic fast-path commands: None

Tuning fields: None

```

ATUED PEPBG PEP Line details NTuneMON V2R6 10:00
Sub Channel Low/High Range = 90-9F
Channel Adapter = CA 11 Line Cntl Def = BSC EBCDIC
Channel Type = 6 Line Type = LEASED
MultiSub Addr = 98 Reply Timer = 0
Channel Command = Unknown Text Timer = 0
Line Adapter ADR = 2 Clockng = External
-----
Current Status
Current Sense
Final Status
Final Sense
-----
=>
F1=HELP F3=RETURN F6=ROLL F10=HEX F12=REFRESH PA1=EXIT PA2=LOG
    
```

Figure 4-25. ATUED PEP Line Details Panel

Description

The ATUED PEP Line Details panel, which is available starting with NCP V7R8, displays information about a partitioned emulation programming (PEP) line.

To display this panel: On the ATUFC Physical Line List panel, as shown on page 4-94, place the cursor under a PEP line and press Enter.

Fields

NCP name (second field on panel)

Name of the NCP that is currently displayed.

Sub Channel Low/High Range

Range of addresses available, as defined by the HICHAN and LOWCHAN keywords on the LINE statement.

Channel Adapter

Actual channel physical address, as defined by the *subch_addr-ca_addr* sub-operands of the ADDRESS keyword on the LINE statement.

Channel Type

Type of channel where EP is executing, as defined by the CA keyword on the LINE statement. Should always be 6 (for CADS).

MultiSub Addr

Subchannel address EP is using, as defined by the *subch_addr* suboperand of the ADDRESS keyword on the LINE statement.

Channel Command

Last command that was issued for the channel. The EP channel commands are defined in “Summary of EP Command Codes” in *NCP and EP Reference Summary and Data Areas*, Volume 2.

Line Adppter ADR

Relative line number of the line that is being used, as defined by the *Inbr* suboperand of the ADDRESS keyword on the LINE statement.

Line Cntl Def

Type of line protocol, as defined by the LNCTL keyword on the GROUP statement. Valid values are *BSC* or *SS*.

Line Type

Type of line connection, as defined by the DIAL keyword on the GROUP statement. Valid values are SWITCHED (for DIAL=YES) or LEASED (DIAL=NO).

Reply Timer

Reply timer value, as defined by the REPLYTO keyword on the GROUP statement.

Text Timer

Text timer value, as defined by the TEXTTO keyword on the GROUP statement.

Clockng

Whether the modem (data set) or the communication scanner for the line provides the clocking, as defined by the CLOCKNG keyword on the LINE statement. Possible **Clockng** values on this panel are:

DIR

The scanner provides clocking and propagates it to the attached DTE. The data signal received by the controller is synchronized with the controller’s clock. You must use a directly attached cable.

External

The modem or other external source provides clocking. You can use either a directly attached cable or a modem cable.

Internal

An internal source provides clocking.

Current Status

The status code of the initial error that was recorded for the failed line operation.

Current Sense

The sense code of the initial error that was recorded for the failed line operation.

Final Status

The status code of the last error that was recorded for the failed line operation.

Final Sense

The sense code of the last error that was recorded for the failed line operation.

PF Keys

F1=HELP

Displays online help for this panel.

F3=RETURN

Returns to the previous NTuneMON panel.

F6=ROLL

Returns to the NetView command line without exiting NTuneMON. To return to NTuneMON from the NetView program, press F6=ROLL or enter

ATUNEMON on the NetView command line.

F10=HEX

Displays the ATUDP Hexadecimal Storage Display panel, as shown on page 4-68, to show the EPCCB control block.

F12=REFRESH

Refreshes the information on this panel. If the NCP was reloaded, the traffic rate information is not accurate until you press F12 again.

PA1=EXIT

Exits NTuneMON.

PA2=LOG

Saves the information on this panel to the NetView log.

ATUEP Ethernet Adapter List Panel

Basic fast-path commands: EP, ETHER, ETHERNET

Tuning fields: None

ATUEP A71NT06			Ethernet Adapter List			NTuneMON V2R1			15:19
				Elapsed Time =					
3745 NCP	ADPT LINE	MAC ADDRESS	FRAMES TRANSMITTED			FRAMES RECEIVED			XMIT QUEUED
			DATA	BRDCSTS	DISCARD	DATA	BRDCSTS	DISCARD	
3	1060	10005AAB001A	-	-	-	-	-	-	0
3	1061	10005AAB001B	-	-	-	-	-	-	0
-	-	-	-	-	-	-	-	-	-
-	-	-	-	-	-	-	-	-	-
-	-	-	-	-	-	-	-	-	-
-	-	-	-	-	-	-	-	-	-
-	-	-	-	-	-	-	-	-	-
-	-	-	-	-	-	-	-	-	-
-	-	-	-	-	-	-	-	-	-
-	-	-	-	-	-	-	-	-	-
-	-	-	-	-	-	-	-	-	-
-	-	-	-	-	-	-	-	-	-
-	-	-	-	-	-	-	-	-	-
-	-	-	-	-	-	-	-	-	-
-	-	-	-	-	-	-	-	-	-
-	-	-	-	-	-	-	-	-	-
=>									
F1=HELP F2=IP DETAILS F3=RETURN F6=ROLL F9=IP STATS F10=HEX F12=REFRESH									
ENTER=ETHERNET STATISTIC DETAILS (POSITION CURSOR) PA1=EXIT PA2=LOG									

Figure 4-26. ATUEP Ethernet Adapter List Panel

Description

The ATUEP Ethernet Adapter List panel, which is available for NCP V6R1 or later releases, displays configuration and traffic information on up to 16 Ethernet-type LAN lines.

For more detailed information on a particular line, place the cursor on the row for that line and press Enter.

To display this panel:

- From the third PF key selection of the ATUNP NCP Selection panel, as shown on page 4-204, press F2.
- From the second PF key selection of the ATUCD CDS NCP Selection panel, as shown on page 4-27, press F2.
- From the third PF key selection of the ATUNW NCP Wide Selection panel, as shown on page 4-212, press F2.
- From the third PF key selection of the ATUSS Summary Status panel, as shown on page 4-260, press F2.
- From the ATUSC1 Channel Adapters panel, as shown on page 4-230, press F2.
- From the ATUSC2 Line Adapters Page 1 panel, as shown on page 4-233, press F2.
- From the ATUSC3 Line Adapters Page 2 panel, as shown on page 4-233, press F2.

ATUEP Ethernet Adapter List Panel

- From the ATUID IP Interface Information Detail panel, as shown on page 4-164, press F7.

For more information, see the descriptions of the panels.

Fields

NCP name (second field on panel)

Name of the NCP that is currently displayed. You can enter a different NCP name in this field to display information on another NCP.

Elapsed Time

Amount of time that has passed since the statistics were last refreshed. This interval is used to calculate traffic rates (frames transmitted and frames received).

The latest statistics are saved as task global variables for the current NetView operation ID until that operator logs off.

The following columns on this panel show information for each adapter:

3745 ADPT

3745 Ethernet-type subsystem (ESS) adapter number. There are two line addresses per adapter.

NCP LINE

Line address, as defined by the ADDRESS keyword on the LINE statement.

MAC ADDRESS

The hardware address used on the Ethernet-type LAN, as defined by the HDWADDR keyword on the IPHOST statement.

FRAMES TRANSMITTED

Number of nonbroadcast frames (DATA) and broadcast frames (BRDCSTS) transmitted, and number of frames discarded (DISCARD). If the number of frames since the last refresh is greater than one per second, this value is shown as a number of frames per second (n/S). If the number of frames is less than one per second, the actual number of frames is shown.

Note: The broadcast field (BRDCSTS) for both frames transmitted and frames received includes any RIP-2 multicast frames.

FRAMES RECEIVED

Number of nonbroadcast frames (DATA) and broadcast frames (BRDCSTS) received, and number of frames discarded (DISCARD). If the number of frames since the last refresh is greater than one per second, this value is shown as a number of frames per second (n/S). If the number of frames is less than one per second, the actual number of frames is shown.

XMIT QUEUED

Number of frames on the outbound queue.

PF Keys

F1=HELP

Displays online help for this panel.

F2=IP DETAILS

Displays the ATUID IP Interface Information Detail panel, as shown on page 4-164, to show detailed information about a specific interface. Place the cursor under the IP address you want and press Enter.

F3=RETURN

Returns to the previous NTuneMON panel.

F6=ROLL

Returns to the NetView command line without exiting NTuneMON. To return to NTuneMON from the NetView program, press F6=ROLL or enter **ATUNEMON** on the NetView command line.

F9=IP STATS

Displays the ATUIS IP Router Statistics Page 1 panel, as shown on page 4-175, to show counters for IP datagrams and ICMP messages.

F10=HEX

Displays the ATUDP Hexadecimal Storage Display panel, as shown on page 4-68, to show the Ethernet statistical counters (ECT) control block.

F12=REFRESH

Refreshes the information on this panel. If the NCP was reloaded, the traffic rate information is not accurate until you press F12 again.

ENTER=ETHERNET STATISTIC DETAILS (POSITION CURSOR)

Displays the ATUET Ethernet Adapter Statistics panel, as shown on page 4-84, which provides more detailed information on a particular line. Place the cursor under the line you want to view and press the Enter key.

PA1=EXIT

Exits NTuneMON.

PA2=LOG

Saves the information on this panel to the NetView log.

ATUET Ethernet Adapter Statistics Panel

Basic fast-path command: ET
 Tuning fields: None

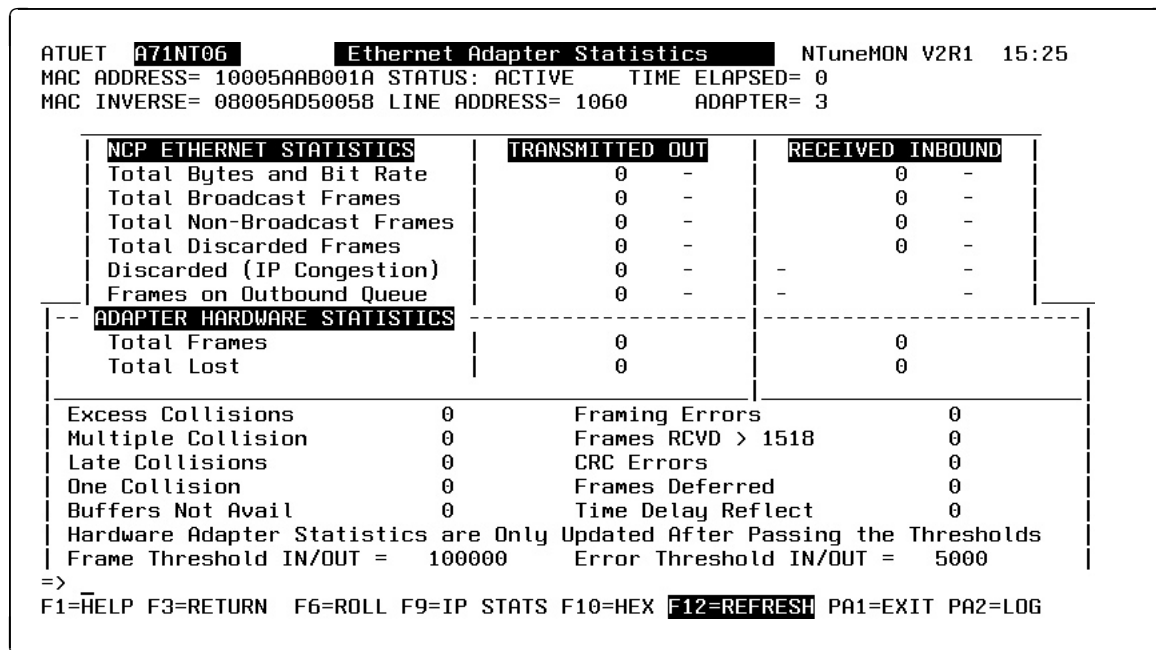

Figure 4-27. ATUET Ethernet Adapter Statistics Panel

Description

The ATUET Ethernet Adapter Statistics panel, which is available for NCP V6R1 or later releases, displays detailed performance information for the Ethernet-type LAN line selected from the ATUEP Ethernet Adapter List panel.

Most of the statistics on this panel are updated each time you refresh the panel. However, the Total Frames and Total Lost fields are updated only when the frame or error threshold is exceeded.

To display this panel: On the ATUEP Ethernet Adapter List panel, as shown on page 4-81, place the cursor under a line on the panel and press Enter.

Fields

NCP name (second field on panel)

Name of the NCP that is currently displayed.

MAC ADDRESS

The hardware address used on the Ethernet-type LAN, as defined by the HDWADDR keyword on the IPHOST statement.

STATUS

Adapter status: ACTIVE or INACTIVE.

TIME ELAPSED

Amount of time that has passed since the statistics were last refreshed. This interval is used to calculate traffic rates. If a change in traffic rate is greater than one frame per second, the change is shown as a number of frames per second (*n/S*). If a change is less than one frame per second, the actual number of frames is shown.

The latest statistics are saved as task global variables for the current NetView operation ID until that operator logs off.

MAC INVERSE

The hardware address in bit transmission order.

LINE ADDRESS

Address of this line, as defined by the ADDRESS keyword on the LINE statement.

ADAPTER

3745 Ethernet-type subsystem (ESS) adapter number for this line.

NCP ETHERNET STATISTICS

The following fields show transmit and receive counts and changes to the transmit and receive rates. If the number of frames since the last refresh is greater than one per second, this value is shown as a number of frames per second (*n/S*). If the number of frames is less than one per second, the actual number of frames is shown.

Total Bytes and Bit Rate

Number of bytes transmitted and received, and traffic rate in bits, megabits, or kilobits per second.

Total Broadcast Frames

Number of broadcast frames transmitted and received. This number includes any RIP-2 multicast frames.

Total Non-Broadcast Frames

Number of non-broadcast frames transmitted and received.

Total Discarded Frames

Number of frames discarded.

Discarded (IP Congestion)

Number of frames discarded due to Internet congestion.

Frames on Outbound Queue

Number of frames on the outbound queue.

ADAPTER HARDWARE STATISTICS

The ESS adapter updates NCP's count of frames transmitted and received and frames lost whenever the corresponding threshold (shown at the bottom of this panel) is exceeded. These thresholds are defined by the FRAMECNT keyword on the LINE statement.

Note: Low thresholds can cause NCP to process large numbers of adapter updates, which can degrade NCP performance. For normal operation, thresholds of 300 or greater are recommended.

Total Frames

Total number of frames transmitted and received since the last time the threshold was reached.

Total Lost

Total number of frames lost due to transmit and receive errors since the last time the threshold was reached.

Miscellaneous Statistics

Many of the following fields show the values of standard Internet counters. These counters are identified in parentheses.

Excess Collisions

Number of frames lost due to excess collisions (RTRY). This occurs when repeated collisions cause the transmitter to fail in 16 transmission attempts.

Multiple Collision

Number of times that collisions required more than one retry to transmit successfully (MORE).

Late Collisions

Number of frames lost due to late collisions (LCOL). This indicates that a collision occurred after the allotted time of the channel elapsed (transmit error).

One Collision

Number of times that a collision required exactly one retry to transmit successfully (ONE).

Buffers Not Avail

Number of frames discarded because buffers were not available (MISS). This occurs when the receiver does not own any ESS adapter receive buffers.

Framing Errors

Number of frames discarded due to framing errors (FRAM). This occurs when the number of bits in an incoming frame is not a multiple of 8 and there was a cyclic redundancy check (CRC) error.

Frames RCVD > 1518

Number of frames larger than 1518 bytes that were received and discarded by the ESS adapter.

The receive buffers used by the ESS adapter are defined to hold a maximum receive frame size of 1518 bytes. The ESS adapter picocode detects frames larger than this and reports the condition to the microcode, which issues this error. The ESS adapter then attempts to receive the frame by data chaining.

CRC Errors

Number of incoming frames discarded due to CRC errors detected by the receiver.

Frames Deferred

Number of transmitted frames the ESS adapter deferred (DEF) because the channel was busy when the adapter was ready to transmit.

Time Delay Reflect

Value of the time delay (or domain) reflectometer (TDR), which is a 10-bit ESS adapter counter that times the interval from the start of a transmission to the occurrence of a collision. This value is useful in determining the distance to a cable fault. This value is updated each time an excess collisions error occurs.

Frame Threshold IN/OUT

Threshold for total number of frames transmitted and the total number of frames received, as defined by the FRAMECNT keyword on the LINE statement. The ESS adapter notifies NCP each time this threshold is reached. The value of the Total Frames field on this panel is updated each time this occurs.

Error Threshold IN/OUT

Threshold for the number of frames lost due to transmission errors and the number of frames lost due to receive errors, as defined by the FRAMECNT keyword on the LINE statement. The ESS adapter notifies NCP each time this threshold is reached. The value of the Total Lost field on this panel is updated each time it occurs.

PF Keys

F1=HELP

Displays online help for this panel.

F3=RETURN

Returns to the previous NTuneMON panel.

F6=ROLL

Returns to the NetView command line without exiting NTuneMON. To return to NTuneMON from the NetView program, press F6=ROLL or enter **ATUNEMON** on the NetView command line.

F9=IP STATS

Displays the ATUIS IP Router Statistics Page 1 panel, as shown on page 4-175, which provides Internet router statistics.

F10=HEX

Displays the ATUDP Hexadecimal Storage Display panel, as shown on page 4-68, to show the Ethernet statistical counters (ECT) control block.

F12=REFRESH

Refreshes the information on this panel. If the NCP was reloaded, the traffic rate information is not accurate until you press F12 again. The Total Frames and Total Lost fields are updated only when the frame or error threshold is exceeded.

PA1=EXIT

Exits NTuneMON.

PA2=LOG

Saves the information on this panel to the NetView log.

ATUFA Frame Relay Support List Panel

Basic fast-path commands: None

Tuning fields: None

```

ATUFA A71NT05 Frame Relay Support List 30 / 991 NTuneMON V2R1 12:20
DEFAULT VIEW= DLCI DUAL= LINE ADDRESS= 32 LINE NAME= FRLN0032
DLCI Type DSAP DLCI Type DSAP
16(10) IPSP N/A | 17(11) IPSP N/A
18(12) IPSP N/A | 19(13) IPSP N/A
20(14) IPSP N/A | 21(15) IPSP N/A
22(16) IPSP N/A | 23(17) IPSP N/A
24(18) IPSP N/A | 48(30) FHSP N/A
49(31) FHSP N/A | 50(32) FHSP N/A
51(33) FHSP N/A | 52(34) FHSP N/A
53(35) FHSP N/A | 54(36) FHSP N/A
55(37) FHSP N/A | 56(38) FHSP N/A
57(39) FHSP N/A | 64(40) SATESP 04
65(41) SATESP 04 | 66(42) SATESP 04
67(43) SATESP 04 | 68(44) SATESP 04
69(45) SATESP 04 | 70(46) SATESP 04
71(47) SATESP 04 | 72(48) SATESP 04
73(49) SATESP 04 | 516(204) IPSP N/A

=>
F1=HELP F2=SUBAREA F3=RETURN F4=FHSP ONLY F5=DLCI ONLY F6=ROLL F7=BACK
ENTER=DLCI DETAILS F8=FORWARD F9=IPSP F10=HEX F12=REFRESH PA1=EXIT PA2=LOG
    
```

Figure 4-28. ATUFA Frame Relay Support List Panel

Description

The ATUFA Frame Relay Support List panel, which is available for NCP V6R2 or later releases, displays DLCIs associated with a frame-relay physical line, a frame-relay line with IP resources defined, or a NTRI frame handler logical line. The DLCI for each support is shown in decimal and hexadecimal formats.

The information displayed for each station is determined by the values in the VIEW and DUAL fields on this panel, as explained in the “Fields” section.

To display this panel:

- On the ATUFC Physical Line List panel, as shown on page 4-94, place the cursor under a frame-relay line and press F2 or F5.
- On the ATUFP Frame Relay Physical Line Details Page 1 panel, as shown on page 4-108, press Enter or F2.
- On the ATUTF NTRI Frame Handler Logical Lines panel, as shown on page 4-291, place the cursor under a NTRI frame handler line and press F2.
- On the ATUTD NTRI Frame Handlers Logical Line Details panel, as shown on page 4-285, press Enter.

Fields

NCP name (second field on panel)

Name of the NCP that is currently displayed. You can enter a different NCP name in this field to display information on another NCP.

DLCI counts

Number of DLCIs currently defined for this line, and highest DLCI that NCP will support on this line.

DEFAULT VIEW

Indicates the DLCIs that are displayed on this panel. Initially, the DLCI displayed in this field is determined by the PF key you pressed to display this panel. To display different DLCIs, you can enter one of the following for VIEW:

DLCI	TESP DLCIs (both subarea and peripheral), FHSP DLCIs, and IPSP DLCIs
FHSP	FHSP DLCIs
TESP	TESP DLCIs (both subarea and peripheral)
IPSP	DLCIs for IP resources defined on a frame-relay line

DUAL (if DLCI or TESP is specified for DEFAULT VIEW)

Indicates the information that is shown for each DLCI. Initially, the information displayed in this field is determined by the PF key you pressed to display this panel. To display additional information on this panel in one of the columns following Type, you can enter SUB, CPNAME, IDBLK, or LINE (if DLCI or TESP is specified for DEFAULT VIEW). See the descriptions of SUB.TG, CPNAME, IDBLK, and LINE later in this text for more information on what is displayed.

LINE ADDRESS

Address of this line, as defined by the ADDRESS keyword on the LINE statement. For a NTRI frame handler logical line, this field will display NONE. To display the DLCIs for a different line, type a different address in this field and press Enter or F12.

LINE NAME

Name of the line. This name is the label on the LINE statement.

DLCI

DLCI address shown in decimal (and in hexadecimal). Defined by the ADDR or DLCI keyword on the PU statement. When stations are multiplexed over the same DLCI, only the first station is displayed. When you place the cursor under a DLCI and press Enter, you get detailed information about that DLCI.

Type

The kind of DLCI:

- For a frame-relay physical line, type is PNTESP (peripheral TESP), SATESP (subarea TESP), or FHSP.
- For a frame-relay line with IP resources defined, type is IPSP.
- For a NTRI frame handler logical line, type is FHSP.

All DLCIs are shown in turquoise, except multistation DLCIs, which are shown in yellow.

ATUFA Frame Relay Support List Panel

DSAP (TESPs)

Destination service access point (DSAP), part of the address field of LLC frames. When stations are multiplexed over the same DLCI, only the first station is displayed.

SUB.TG (SATESPs)

Adjacent subarea and transmission group number. Displayed if the resource type is SATESP and if SUB is specified for DUAL.

CPNAME (PNTESPs)

Name of the type 2.1 PU attached to this station. Displayed if the resource type is PNTESP and if CPNAME is specified for DUAL.

IDBLK (PNTESPs)

The IDBLK and IDNUM of the PU attached to this station. Displayed if the resource type is PNTESP and if IDBLK is specified for DUAL.

LINE (PNTESPs; SATESPs)

Name of the logical line. Displayed if the resource type is PNTESP or SATESP and if LINE is specified for DUAL.

PF Keys

F1=HELP

Displays online help for this panel.

F2=SUBAREA

Displays all the subarea DLCIs for this line. The subarea address and transmission group number are shown as SUB.TG next to each SATESP DLCI. This is the same as DEFAULT VIEW=DLCI and DUAL=SUB.

F3=RETURN

Returns to the previous NTuneMON panel.

F4=FHSP ONLY

Displays all FHSP DLCIs. This is the same as DEFAULT VIEW=FHSP and DUAL=blank.

F5=DLCI ONLY

Displays all the DLCIs for this line. This is the same as DEFAULT VIEW=DLCI and DUAL=blank.

F6=ROLL

Returns to the NetView command line without exiting NTuneMON. To return to NTuneMON from the NetView program, press F6=ROLL or enter **ATUNEMON** on the NetView command line.

F7=BACK

Scrolls the panel data backward one screen.

ENTER=DLCI DETAILS

Displays one of the following panels:

- When the cursor is under a TESP DLCI, the ATUFT1 Frame Relay Terminating Equipment Details Page 1 panel, as shown on page 4-135, is displayed. This panel shows detailed information on the logical line associated with a particular DLCI.
- When the cursor is under an FHSP DLCI, the ATUFS1 Frame Relay Switching Equipment Page 1 panel, as shown on page 4-127, is displayed.

played. This panel shows information on an NCP FRSE, including a graphic representation of the routes through the NCP FHSPs.

- When the cursor is under an IPSP DLCI, the ATUID IP Interface Information Detail panel, as shown on page 4-164, is displayed. This panel shows detailed information about a specific IP interface.
- When the cursor is under a DLCI (yellow) with multiplexed stations, the ATUFL Frame Relay Multi Station List panel, as shown on page 4-105, is displayed. This panel shows all the stations multiplexed over the selected DLCI.

Place the cursor under the DLCI you want to view and press Enter.

F8=FORWARD

Scrolls the panel data forward one screen.

F9=IPSP

Displays all IPSP DLCIs. This is the same as DEFAULT VIEW=IPSP and DUAL=blank.

F10=HEX

Displays the ATUDP Hexadecimal Storage Display panel, as shown on page 4-68, to show the:

- Common physical unit block (CUB) for a IBM 3745 FHSP DLCI or an IPSP DLCI
- Logical link control block (LLB) for a IBM 3745 TESP DLCI
- Station control block extension (SCE) for a IBM 3746 Model 900 DLCI

Place the cursor under the DLCI you want to view and press F10.

F12=REFRESH

Refreshes the information on this panel.

PA1=EXIT

Exits NTuneMON.

PA2=LOG

Saves the information on this panel to the NetView log.

ATUFB Frame Relay DLCI CIR Parameters Panel

Basic fast-path commands: None

Tuning fields: Bc, Be, Tc

ATUFB A13SUTB Frame Relay DLCI CIR Parameters				NTuneMON V2R5 10:00			
Line Name = A13F2336		Datablk = N/A					
DLCI Address	Bc	Be	Tc	DLCI Address	Bc	Be	Tc
0(0)	1	1	1				
13(19)	6	6	5				
15(21)	8	8	5				
17(23)	4	4	10				
18(24)	2	1	1				
20(32)	2	2	10				

=>
 F1=HELP F3=RETURN PA1=EXIT F6=ROLL F7=BACK F8=FORWARD
 F10=HEX F12=RFRSH

Figure 4-29. ATUFB Frame Relay DLCI CIR Parameters Panel

Description

The ATUFB Frame Relay DLCI CIR Parameters panel, available starting with NCP V7R7, shows the DLCI parameter table for the associated 3746 Model 900-attached frame-relay physical line. The DLCI parameter table contains the DLCI addresses and associated CIR parameter values for the line.

To display this panel:

- From the ATUFP Frame Relay Physical Line Details Page 1 panel, as shown on page 4-108, press F4 when that panel is displaying a 3746 Model 900 line.
- From the ATUFP3 Frame Relay Details Page 3 panel, as shown on page 4-122, press F11 when that panel is displaying a 3746 Model 900 line for which CIR=YES.

Fields

If you coded CIR=YES and coded at least one DLCI statement for the line, the DLCI parameter table has at least one entry. The first entry in the table is always the “Default” entry.

NCP name (second field on panel)

Name of the NCP that is currently displayed.

Line Name

Name of this line. This name is the label on the LINE statement.

Datablk

Minimum guaranteed transmission bandwidth (in bytes) that can be allocated to a resource, as defined by the DATABLEK keyword on the LINE statement.

ATUFB Frame Relay DLCI CIR Parameters Panel

The DATABLK keyword is used with the Bc, Be, and Tc values to determine the CIR parameters for a designated DLCI.

DLCI Address

The DLCI address as specified by the ID keyword on the DLCI statement.

Bc

Committed burst size, as specified by the *Bc* parameter of the CIR keyword on the DLCI statement. *Bc* is multiplied by *Datablk* to determine the maximum committed amount of data that a user can offer to the network during time interval *Tc*.

Be

Excess burst size, as specified by the *Be* parameter of the CIR keyword on the DLCI statement. *Be* is multiplied by *Datablk* to determine the maximum amount of data by which a user can exceed the committed burst size (*Bc*) during time interval *Tc*.

Tc

Committed rate measurement interval, as specified by the *Tc* parameter of the CIR keyword on the DLCI statement.

PF Keys

F1=HELP

Displays online help for this panel.

F3=RETURN

Returns to the previous NTuneMON panel.

F5=MODIFY

Available when the operator has tuning authority and NTuneNCP is included. For more information, refer to Chapter 5, Using the NTuneNCP Tuning Feature.

Updates the NCP tuning parameter with the modified value. If the modification is not valid, the field turns reverse-video pink, and you are prompted to correct the value and resubmit it.

F6=ROLL

Returns to the NetView command line without exiting NTuneMON. To return to NTuneMON from the NetView program, press F6=ROLL or enter **ATUNEMON** on the NetView command line.

F7=BACK

Scrolls the panel data backward one screen.

F8=FORWARD

Scrolls the panel data forward one screen.

F10=HEX

Displays the ATUDP Hexadecimal Storage Display panel, as shown on page 4-68, to show the CIR table control block.

F12=REFRESH

Refreshes the information on this panel.

PA1=EXIT

Exits NTuneMON.

PA2=LOG

Saves the information on this panel to the NetView log.

ATUFC Physical Line List Panel

Basic fast-path commands: BSC, BISYNC, FC, FR, FRELAY, FRAMERELAY, PEP, SDLC

Tuning fields: None

ATUFC		Physical Line List		NTuneMON V2R6 10:39					
Adapter Position = 4		Adapter Type = TSS							
ADDR	NAME	TYPE	USE (ACT/TOT)	STATUS	ADDR	NAME	TYPE	USE (ACT/TOT)	STATUS
0	A12L00	SDLC		INACTIV					
3	A12L03	SDLC		INACTIV					
4	A12L04	SDLC		ACTIVE					
5	A12L05	SDLC		INACTIV					
16	A12L16	SDLC		INACTIV					
20	A12F20	FRELAY	0/ 0	INACTIV					

=>

F1=HELP F2=DLCI/SUBAREA F3=RETURN F5=DLCI ONLY
 F6=ROLL F7=BACK F8=FORWARD F9=STATIONS (PUs) F10=HEX
ENTER=PHYSICAL LINE DETAILS F12=REFRESH PA1=EXIT PA2=LOG

Figure 4-30. ATUFC Physical Line List Panel

Description

The ATUFC Physical Line List panel shows the status of certain types of lines defined to NCP. This panel is also the entry point to NTuneMON support for SDLC, frame-relay, and pre-SNA resources. For overviews of those panel groups, see:

- SDLC — Figure 1-7 on page 1-12
- Frame-relay — Figure 1-5 on page 1-10
- Pre-SNA — Figure 1-3 on page 1-8

To display this panel:

- From the third PF key selection of the ATUNP NCP Selection panel, as shown on page 4-204, press F5 or F10.
- From the second PF key selection of the ATUCD CDS NCP Selection panel, as shown on page 4-27, press F4 or F5.
- From the third PF key selection of the ATUNW NCP Wide Selection panel, as shown on page 4-212, press F4 or F5.
- From the third PF key selection of the ATUSS Summary Status panel, as shown on page 4-260, press F4 or F5.
- On the ATUSC2 Line Adapters Page 1 panel, as shown on page 4-233, or on the ATUSC3 Line Adapters Page 2 panel, as shown on page 4-233, place the

cursor under the NCP line address of an HPTSS or TSS adapter and press Enter.

- On the ATUSC4 3746 Model 900 Adapters panel, as shown on page 4-237, place the cursor under the line address of a CLP adapter and press Enter.

See the descriptions of these panels for detailed information.

Fields

NCP name (second field on panel)

Name of the NCP that is currently displayed. When all adapters for SDLC, frame-relay, or pre-SNA physical lines are being displayed, you can type a different NCP name in this field to display information on another NCP. Conversely, when only the lines for a specific adapter are being displayed, the NCP name is not modifiable.

Adapter Position

Line adapter physical position. ALL if all of the adapters are displayed.

Adapter Type

Can be any of the following:

- TSS** Transmission subsystem
- HPTSS** High-performance transmission subsystem
- CLP** Communication line processor
- N/A** If adapter position is ALL

The following columns on this panel show information for each physical line:

ADDR

Address of this line, as defined by the ADDRESS keyword on the LINE statement.

Note: The adapter position is used to determine the relative line number for the line.

NAME

Name of this line, as defined by the label on the LINE statement. For NCP V4R1 and NCP V4R2, this field is blank. In addition, this field is blank for PEP, bisync, and start-stop lines.

Notes:

1. Line names are shown in blue, except for names of SDLC peripheral lines, which are shown in turquoise.
2. When you come to this panel from panel ATUSC4, the line name displayed **for NPSI ODLG lines** is the line name that is known by the hardware and not the line name defined in your gen.

TYPE

The type of line protocol. One of the following:

BSC	Bisync line
EP	EP line
FRELAY	Frame-relay line
ISDN	ISDN line
NEO	User line
SDLC	SDLC line
SS	Start-stop line
X25	SNA X.25 ODLC line

USE (ACT/TOT)

In this dual-use column, USE applies if SDLC lines are being displayed. ACT/TOT applies if frame-relay lines are being displayed.

USE For spare SDLC lines, SPARE. For redefinable SDLC lines, REDEF. Otherwise, this field is blank.

(ACT/TOT) Active and total frame-relay logical lines. If a value exceeds 999, then *** is displayed.

ACT Number of active frame-relay logical lines. Logical lines are included in the active count when they are activated over a specific physical. For 3745 lines, logical subarea lines are always included in the active count. Note that the active count can be greater than the total count because pooled peripheral logical lines (that is, lines genned as PHYSRSC=NONE) are included in the active count of the physical line that they are active over.

TOT Total number of frame-relay logical lines defined. Only the logical lines that are reserved for a particular physical (that is, lines genned as PHYSRSC=physical name) are included in that physical line's TOT count.

STATUS

Physical line status. This field will be one of the following:

PEND ACTLINK	An activate link command (ACTLINK) is in progress.
ACTIVE	An ACTLINK has been processed, and the line is active.
PEND DACTLNK	A deactivate link command (DACTLINK) is in progress.
INACTIVE	A DACTLINK has been processed, and the line is inactive. Inactive lines are highlighted in reverse-video red.
FORCE DEACT	The line has been forced into deactivation. (A force deactivate command was issued from VTAM.)

PEND ANS	Line quiescence is pending due to automatic network shutdown (ANS).
PEND SWITCH	A switch from primary to secondary is in progress.
OLT TESTING	Online line testing (OLT) is in progress.
WRAP TESTING	Wrap testing is in progress.

All lines except active lines are highlighted in reverse-video red.

PF Keys

F1=HELP

Displays online help for this panel.

F2=DLCI/SUBAREA (frame-relay lines)

Displays the ATUFA Frame Relay Support List panel, as shown on page 4-88, to show all the DLCIs for a particular line. The subarea address is shown next to each SATESP DLCI. Place the cursor under the frame-relay line you want to view and press F2.

F3=RETURN

Returns to the previous NTuneMON panel.

F4=SDLC PN PARMS (peripheral SDLC lines)

Displays the ATUSP1 SDLC Peripheral Line Parameters Page 1 panel, as shown on page 4-249, to show configuration parameters for a peripheral SDLC line. Peripheral SDLC line names are shown in turquoise. Place the cursor under a peripheral SDLC line and press F4.

F5=DLCI ONLY (frame-relay lines)

Displays the ATUFA Frame Relay Support List panel, as shown on page 4-88, which shows all the DLCIs for a particular line. Place the cursor under the frame-relay line you want to view and press F5.

F6=ROLL

Returns to the NetView command line without exiting NTuneMON. To return to NTuneMON from the NetView program, press F6=ROLL or enter **ATUNEMON** on the NetView command line.

F7=BACK

Scrolls the panel data backward one screen.

F8=FORWARD

Scrolls the panel data forward one screen.

F9=STATIONS (PUs) (SDLC lines)

Displays the ATUSL SDLC Stations List panel, as shown on page 4-246, to show information on the stations for a particular SDLC line. Place the cursor under the SDLC line you want to view and press F9.

F10=HEX

Displays the ATUDP Hexadecimal Storage Display panel, as shown on page 4-68, to show the:

- Parameter/status area (PSA) control block if you entered this panel from:
 - ATUSC2 Line Adapters Page 1, ATUSC3 Line Adapters Page 2, or ATUSC4 3746 Model 900 Adapters panel

ATUFC Physical Line List Panel

- ATUNP NCP Selection, ATUCD CDS NCP Selection, ATUNW NCP Wide Selection, or ATUSS Summary Status panel by typing SDLC on the command line or by selecting the SDLC PF key from one of the alternate PF key selections
- Physical link control block (PLB) for a 3745 line or line control block (LKB) for a 3746 Model 900 line if you entered this panel from the ATUNP NCP Selection, ATUCD CDS NCP Selection, ATUNW NCP Wide Selection, or ATUSS Summary Status panel by typing FRELAY on the command line or by selecting the FRELAY (or Frame Relay) PF key from one of the alternate PF key selections.

Place the cursor under the line you want to view and press F10.

F11=SPARE/REDEF LINES (spare and redefinable SDLC lines)

Displays just the spare and redefinable SDLC lines.

ENTER=PHYSICAL LINE DETAILS

Displays one of the following panels to show detailed information about the line:

- When the cursor is under a row for a frame-relay line, the ATUFP Frame Relay Physical Line Details Page 1 Details panel, as shown on page 4-108, is displayed.
- When the cursor is under a row for an SDLC line, the ATUPL SDLC Physical Line Details panel, as shown on page 4-217, is displayed.
- When the cursor is under a row for a bisync or start-stop line, the ATUPS Bisync/SS Line Details panel, as shown on page 4-223, is displayed.
- When the cursor is under a row for a PEP line, the ATUED PEP Line Details panel, as shown on page 4-78, is displayed.

F12=REFRESH

Refreshes the information on this panel.

PA1=EXIT

Exits NTuneMON.

PA2=LOG

Saves the information on this panel to the NetView log.

ATUFD Frame Relay DLCI to Balance Table Panel

Basic fast-path commands: None

Tuning fields: Bal Factor

```

ATUFD  A13V7R8  Frame Relay DLCI to Balance Table  NTuneMON V2R6  13:34
NAME= A13F2656  LINE ADDR= 2656  CLP  Full  MAXFRAME = 2048
LINE STATUS = INACTIVE
DLCI ADDR  Bal Factor  Entries      DLCI ADDR  Bal Factor  Entries
DEFAULT    1           N/A
26 (1A)    1           0
27 (1B)    1           0

=>
F1=HELP    F3=ReTurn    F5=MODIFY    F6=ROLL    F7=BACK    F8=FORWARD
F10=HEX    F12=REFRESH  PA1=EXIT    PA2=LOG
    
```

Figure 4-31. ATUFD Frame Relay DLCI to Balance Table Panel

Description

The ATUFD Frame Relay DLCI to Balance Table panel is available starting with NCP V7R7. It displays each DLCI for which a corresponding DLCI statement specifies the BALANCE keyword, and it displays the BALANCE keyword value for that DLCI.

To display this panel:

- On the ATUFP Frame Relay Physical Line Details Page 1 panel, as shown on page 4-108, press F7.
- On the ATUFP2 Frame Relay Details Page 2 panel, as shown on page 4-117, press F9.

Fields

NCP name (second field on panel)

Name of the NCP that is currently displayed.

NAME

Name of this line. This name is the label on the LINE statement.

LINE ADDR

Address of this line as defined by the ADDRESS keyword on the LINE statement.

Adapter Type

HPTSS, TSS, or CLP, followed by "Full" to indicate full-duplex.

ATUFD Frame Relay DLCI to Balance Table Panel

MAXFRAME

Maximum frame size, in bytes, for this line as defined by the MAXFRAME keyword on the LINE statement.

LINE STATUS (starting with NCP V7R8)

Line status; one of the following. Inactive lines are highlighted in reverse-video red.

PEND ACTLINK An activate link command (ACTLINK) is in progress.

ACTIVE An ACTLINK has been processed, and the line is active.

PEND DACTLNK A deactivate link command (DACTLINK) is in progress.

INACTIVE A DACTLINK has been processed, and the line is inactive.

FORCE DEACT The line has been forced into deactivation. (A force deactivate command was issued from VTAM.)

PEND ANS Line quiescence is pending due to automatic network shutdown (ANS).

DLCI ADDR

The DLCI address as specified by the ID keyword on the DLCI statement.

3746 Model 900 Lines: If this field has the value DEFAULT, then the balancing factor is the balancing factor that is used for those DLCIs that do not have explicit DLCI statements coded (i.e., any DLCIs that do not appear in this list).

Bal Factor

The balancing factor specified for the DLCI by the BALANCE keyword on the DLCI statement.

3746 Model 900 Lines: Bal Factor can have a value of 0 for the DEFAULT entry. This indicates that there is no default balancing factor. Bal Factor can also have a value of AUTO, which indicates that the auto-adaptive balancing function balances connections over the DLCI.

Entries

The number of peripheral BAN connections currently supported for the DLCI.

3746 Model 900 Lines: If a DLCI is being shared between NCP and the NNP, the number of entries reflect only those connections activated through NCP.

PF Keys

F1=HELP

Displays online help for this panel.

F3=RETURN

Returns to the previous NTuneMON panel.

F5=MODIFY

Available when the operator has tuning authority, and NTuneNCP is included. For more information, refer to Chapter 5, Using the NTuneNCP Tuning Feature.

ATUFD Frame Relay DLCI to Balance Table Panel

Updates the NCP tuning parameter with the modified value. If the modification is not valid, the field turns reverse-video pink, and you are prompted to correct the value and resubmit it.

F6=ROLL

Returns to the NetView command line without exiting NTuneMON. To return to NTuneMON from the NetView program, press F6=ROLL or enter **ATUNEMON** on the NetView command line.

F7=BACK

Scrolls the panel data backward one screen.

F8=FORWARD

Scrolls the panel data forward one screen.

F10=HEX

Displays the ATUDP Hexadecimal Storage Display panel, as shown on page 4-68, to show the DLCI-to-balance table (DTB) control block.

F12=REFRESH

Refreshes the information on this panel.

PA1=EXIT

Exits NTuneMON.

PA2=LOG

Saves the information on this panel to the NetView log.

ATUFI Frame-Relay IP Link Statistics Panel

Basic fast-path commands: None
 Tuning fields: OUTBOUND QUEUE SIZE Maximum

```

ATUFI A71C901 Frame-Relay IP Link Statistics NTuneMON V2R5 09:09

                Station IP Statistics
DLCI           = 192(0C0)      Status: INACTIVE      Time Elapsed= 0
IP Address     = 12.0.16.0     Line Address= 16
OUTBOUND QUEUE SIZE Current/Maximum = 0 / 16000

                IP Link Statistics

+-----+-----+-----+
| FRAME-RELAY IP STATISTICS | TRANSMITTED | RECEIVED |
+-----+-----+-----+
| Total IP Bytes and Bit Rate | 0 -         | 0 -         |
| Total IP Frames            | 0 -         | 0 -         |
| Total IP Discarded Frames  | 0 -         | 0 0         |
| Discarded (IP Congestion) | N/A N/A    | 0 -         |
| IP Frames on Outbound Queue | 0 N/A      | N/A N/A    |
+-----+-----+-----+

=> ATUM017 Press F12 to see Traffic or Polling rates
F1=HELP F2=IP STATS F3=RETURN F4=IPLIST F5=MODIFY F6=ROLL F10=HEX PA1=EXIT
ENTER=IP INTERFACE INFORMATION DETAILS F12=REFRESH/TRAFFIC RATES PA2=LOG
    
```

Figure 4-32. ATUFI Frame-Relay IP Link Statistics Panel

Description

The ATUFI Frame-Relay IP Link Statistics panel is available for NCP V7R3 or later releases. It displays information about the first IPSP on the frame-relay line and IP traffic statistics for the frame-relay line.

To display this panel: On the ATUID IP Interface Information Detail panel, as shown on page 4-164, press F7.

Fields

NCP name (second field on panel)

Name of the NCP that is currently displayed.

Station IP Statistics

The following fields describe the first IPSP on the frame-relay line.

DLCI

DLCI address shown in decimal (and in hexadecimal), as defined by the ADDR or DLCI keyword on the PU statement.

Status

Status of the IPSP: ACTIVE or INACTIVE.

Time Elapsed

Amount of time that has passed since the statistics were last refreshed.

IP Address

Four-byte internet address of the associated interface as defined by the LADDR keyword on the PU or IPLOCAL statement.

Line Address

Physical line address as defined by the ADDRESS keyword on the LINE statement.

OUTBOUND QUEUE SIZE Current/Maximum

Current amount of data (in bytes) that is queued for transmission and Maximum amount of data (in bytes) that can be queued for transmission as defined by the IPQLIM keyword on the PU statement.

IP Link Statistics

The following fields show frame-relay IP statistics for TRANSMITTED and RECEIVED counts and changes to the TRANSMITTED and RECEIVED rates. If the number of frames since the last refresh is greater than one per second, this value is shown as a number of frames per second (n/S). If the number of frames is less than one per second, the actual number of frames is shown. If information is not available, a dash (–) is displayed.

Total IP Bytes and Bit Rate

Number of bytes transmitted and received, and traffic rate in bits, megabits, or kilobits per second.

Total IP Frames

Number of frames transmitted and received.

Total IP Discarded Frames

Number of frames discarded.

Discarded (IP Congestion)

Number of frames discarded due to internet congestion. This information is not applicable (N/A) for the TRANSMITTED columns.

IP Frames on Outbound Queue

Number of frames on the outbound queue. This information is not applicable (N/A) for the TRANSMITTED change rate column or for the RECEIVED columns.

PF Keys

F1=HELP

Displays online help for this panel.

F2=IP STATS

Displays the ATUIS IP Router Statistics Page 1 panel, as shown on page 4-175, to show global counters for IP datagrams and ICMP messages.

F3=RETURN

Returns to the previous NTuneMON panel.

F4=IPLIST

Displays the ATUIL IP Interface Information panel, as shown on page 4-169, to show information about an IP interface.

F5=MODIFY (starting with NCP V7R3)

Available when the operator has tuning authority and NTuneNCP is included. For more information, refer to Chapter 5, Using the NTuneNCP Tuning Feature.

Updates the NCP tuning parameter with the modified value. If the modification is not valid, the field turns reverse-video pink, and you are prompted to correct the value and resubmit it.

ATUFI Frame-Relay IP Link Statistics Panel

F6=ROLL

Returns to the NetView command line without exiting NTuneMON. To return to NTuneMON from the NetView program, press F6=ROLL or enter **ATUNEMON** on the NetView command line.

F10=HEX

Displays the ATUDP Hexadecimal Storage Display panel, as shown on page 4-68, to show the Ethernet statistical counters (ECT) control block.

PA1=EXIT

Exits NTuneMON.

ENTER=IP INTERFACE INFORMATION DETAILS

Displays the ATUID IP Interface Information Detail panel, as shown on page 4-164, to show detailed information about an IP interface.

F12=REFRESH/TRAFFIC RATES

Refreshes the information on this panel and displays traffic rates.

PA2=LOG

Saves the information on this panel to the NetView log.

ATUFL Frame Relay Multi Station List Panel

Basic fast-path commands: None

Tuning fields: None

```

ATUFL A71SVTB Frame Relay Multi Station List NTuneMON V2R5 11:19
DLCI= 18(24) VIEW=DLCI DUAL= LINE= A71F01
Number of Stations = 2
Type MAC Address DSAP TYPE MAC Address DSAP
IPSP - -
SATESP 000000000421 04

=>
F1=HELP F3=RETURN F6=ROLL F7=BACK F8=FORWARD
Enter = Station F10=HEX F12=RFRSH PA1=EXIT PA2=LOG
    
```

Figure 4-33. ATUFL Frame Relay Multi Station List Panel

Description

The ATUFL Frame Relay Multi Station List panel, supported for NCP V7R3 and later releases, displays the frame-relay stations multiplexed over a DLCI. These stations can be either SNA BNN/BAN (multiple) with IP (single) or SNA INN (single) with IP (single).

The stations displayed on this panel include any IP (limit of one) and INN stations (limit of one) regardless of state and any BNN/BAN stations that are active. A BNN/BAN station that is not active is not normally displayed unless its control block information is retrieved during a state transition. Active stations are shown in yellow; inactive stations are shown in turquoise.

The information displayed for each station is determined by the values in the VIEW and DUAL fields on this panel, as explained in the “Fields” section.

To display this panel: On the ATUFA Frame Relay Support List panel, as shown on 4-88, place the cursor under a multistation (yellow) DLCI and press Enter.

Fields

NCP name (second field on panel)

Name of the NCP that is currently displayed.

DLCI

Address of the multiplexed DLCI in decimal (and hexadecimal).

VIEW

Indicates the station types that are displayed on this panel. Initially, the station type displayed in this field is determined by the value of VIEW on the

ATUFL Frame Relay Multi Station List Panel

ATUFA panel. To display different station types, you can enter one of the following for VIEW:

DLCI

All stations multiplexed on this DLCI

TESP

All SNA stations multiplexed on this DLCI

IPSP

IP station on this DLCI

If the VIEW field is blank, then the station list area will also be blank. The station count will still be provided.

Note: Displaying many stations on this panel can cause high NetView CPU and storage use.

DUAL

Indicates the information that is shown for each DLCI. The default is DESTADDR. To change the information on this panel, you can enter DESTADDR, SUB, CPNAME, IDBLK, or LINE. See the description of "Second column of table", later in this text, for information on what is displayed.

LINE

Name of the frame-relay physical line.

Number of Stations

Number of stations displayed for this DLCI.

Station List Area

Type

The station type (IPSP, PNTESP, or SATESP).

Second column of table

This column's heading and contents depend on the value of the DUAL field:

DUAL=	Column Heading	Column Contents
DESTADDR	MAC Address	Destination MAC address (BAN only) and destination SAP (DSAP) address (PNTESPs and SATESPs)
SUB	SUB.TG	Adjacent subarea and transmission group number (SATESPs)
CPNAME	CPNAME	Name of the type 2.1 PU attached to this station (PNTESPs)
IDBLK	IDBLK	IDBLK and IDNUM of the PU attached to this station (PNTESPs)
LINE	LINE NAME	Name of the logical line (SATESPs and PNTESPs)

Note: The CPNAME and IDBLK/IDNUM values might be inaccurate for non-active stations.

Third column of table

DSAP addresses under the heading **DSAP**, if DUAL=DESTADDR. Otherwise blank.

PF Keys

F1=HELP

Displays online help for this panel.

F3=RETURN

Returns to the previous NTuneMON panel.

F6=ROLL

Returns to the NetView command line without exiting NTuneMON. To return to NTuneMON from the NetView program, press F6=ROLL or enter **ATUNEMON** on the NetView command line.

F7=BACK

Scrolls the panel data backward one screen.

F8=FORWARD

Scrolls the panel data forward one screen.

ENTER = Station

Displays one of the following panels:

- If the cursor is under a SNA station, the ATUFT1 Frame Relay Terminating Equipment Details Page 1 panel, as shown on page 4-135
- If the cursor is under an IP station, the ATUID IP Interface Information Detail panel, as shown on page 4-164

Place the cursor under the station you want to view and press Enter.

F10=HEX

Displays the ATUDP Hexadecimal Storage Display panel, as shown on page 4-68, to show the:

- Hash entry control block (HEB) for an IPSP station
- Station control block extension (SCE) for a 3746 Model 900 station
- Common physical unit block (CUB) for all other stations

Place the cursor under the station you want to view and press F10.

F12=RFRSH

Refreshes the information on this panel.

PA1=EXIT

Exits NTuneMON.

PA2=LOG

Saves the information on this panel to the NetView log.

ATUFP Frame Relay Physical Line Details Page 1 Panel

Basic fast-path commands: None

Tuning fields: Line Speed, NRZI, TITIMER, TRANSBUF, DYNWIND(nw), DYNWIND(dw), DYNWIND(dwc), DYNWIND(dwd), DYNWIND(twc), DYNWIND(mww), Receive Errors THRESH, LMI

```

ATUFP A12V7R8 Frame Relay Physical Line Details NTuneMON V2R6 16:31
Physical Line Details Page 1 Elapsed Time =30
Local Mgmt Interface DLCI 0
Line Addr = 20 LEASED
Line Name = A12F20 Status = INACTIVE
Line Type = TSS Full Duplex
Line Speed= 56000
NRZI = NO DYNWIND(nw) = 4
TITIMER = 60.0 DYNWIND(dw) = 1
CLOCKNG = EXT DYNWIND(dwc) = 1
MAXDLCI = 432 DYNWIND(dwd) = 1
TRANSBUF = 0 DYNWIND(twc) = YES
MAXFRAME = 2106 DYNWIND(mww) = 47
LMI = ANSI NO ECHO
LMI Activation Pending
LVL 3 Discards = 0
LVL 5 Discards = 0
PU Status = INACTIVE

Physical Line Frame Statistics
Transmitted Received
Total Frames 0 - 0 -
Total Retries 0 - -
I-Frame Retries 0 - -
Frame Format Errors 0 -
Receive Errors CUR: 0 THRESH: 64
Last PSA Error Status
00000000 00000000 00000000 00000000
USER NETWORK
N391= 6 -
N392= 3/0 3/0
N393= 4 4
T391= 10 Sec -
T392= - 15 Sec
SEND= 0(00) 0(00)
RCVD= 0(00) 0(00)
Source Addr = N/A
NO ISDN BACKUP
=> ATUM017 Press F12 to see Traffic or Polling rates
F1=HELP F2=DLCI/SUBA F3=RTN F4=DLCI CIR F5=MODIF F6=ROLL F7=BAL FA F8=FP PG2
ENTER=ONLY DLCIs F9=ISDN F10=HEX F12=RFRSH PA1=EXIT PA2=LOG
    
```

Figure 4-34. ATUFP Frame Relay Physical Line Details Page 1 Panel

Description

The ATUFP Frame Relay Physical Line Details Page 1 panel, which is available for NCP V6R1 or later releases, displays detailed information on a single frame-relay physical line.

To display this panel:

- On the ATUFC Physical Line List panel, as shown on page 4-94, place the cursor under a frame-relay line and press Enter.
- On the ATUFS1 Frame Relay Switching Equipment Page 1 panel, as shown on page 4-127, place the cursor under the LINE ADDR field of a frame-relay physical line and press Enter.
- On the ATUFP2 Frame Relay Details Page 2 panel, as shown on page 4-117, press F7.
- On the ATUFP3 Frame Relay Details Page 3 panel, as shown on page 4-122, press F8.

Fields

NCP name (second field on panel)

Name of the NCP that is currently displayed. You can enter a different NCP name in this field to display information on another NCP.

Elapsed Time

The amount of time that has passed from panel entry until the panel was refreshed, or the amount of time that has passed since the statistics were last refreshed.

Physical Line Details

Line Addr

Address of this line as defined by the ADDRESS keyword on the LINE statement. The address is followed by LEASED or SWITCHED, to indicate whether the line is leased (DIAL=NO) or switched (DIAL=YES), as defined by the DIAL keyword on the GROUP statement

Line Name

Name of this line. This name is the label on the LINE statement.

Line Type

- Line adapter type: TSS (low speed), HPTSS (high speed), or CLP (communication line processor)
- Line type: Full Duplex or Half Duplex
- Whether the line is direct-attached

Line Speed

Data rate for the line in bits per second as defined by the *rate* suboperand of the SPEED keyword on the LINE statement. This is the rate at which the devices communicate with the communication controller.

NCP V7R6 and Earlier Releases: The SPEED value displayed on this panel might differ from the rate specified for the SPEED keyword:

For TSS and HPTSS adapters with CLOCKNG=EXT, following are the displayed values for SPEED. These values are valid only for NCP V5R4 and later, running on a 3745.

50, 75, 100, 110, 134, 200, 300, 600, 1200, 2400, 4800, 9600, 19200, 38400, 55855, 245760, 1843200

If a value in the above list was specified for SPEED, the panel displays that value. If an unlisted value less than 1843200 was specified for SPEED, the panel displays the next highest listed value. For example, if 60 was specified, the panel displays 75. If a value greater than 1843200 was specified for SPEED, the panel displays 1843200.

For 3746 Model 900 lines with CLOCKNG=EXT, the value displayed for SPEED represents a range of speeds as shown in Table 4-1 on page 4-110.

Table 4-1. SPEED Values for IBM 3746 Model 900 Frame-Relay Lines When CLOCKNG=EXT and VERSION<V7R7

Displayed SPEED Value	Actual Data Rate (SPEED) Values for CLOCKNG=EXT
19200	>= 600 and <= 32000
38400	> 32000 and <= 64000
256000	> 64000 and <= 256000
512000	> 256000

NRZI

YES or NO to specify whether the data terminal equipment at the end of the frame-relay line must operate in non-return-to zero change-on-ones mode (YES) or in non-return-to-zero mode (NO). Defined by the NRZI keyword on the LINE statement.

TITIMER (starting with NCP V7R1)

Inactivity Timer (TI) interval, in seconds, that NCP is to wait for a transmitted frame from an adjacent station before sending a poll command. Defined by the TITIMER keyword on the LINE statement for a physical frame-relay line. The TI value that is specified on the physical line will be used by the logical lines associated with that physical line.

CLOCKNG

Whether the modem (data set) or the communication scanner for the line provides the clocking, as defined by the CLOCKNG keyword on the LINE statement.

DIRECT

The scanner provides clocking and propagates it to the attached DTE. The data signal received by the controller is synchronized with the controller's clock. You must use a directly attached cable.

EXT

The modem or other external source provides clocking. You can use either a directly attached cable or a modem cable.

MAXDLCI

Maximum DLCI address for this line, as specified by the MAXDLCI keyword.

TRANSBUF (starting with NCP V7R7; not applicable to 3746 Model 900)

Maximum number of frames that will be queued for a TSS or HPTSS adapter, as defined by the TRANSBUF keyword on the LINE statement.

Status

Line status; one of the following. Inactive lines are highlighted in reverse-video red.

- | **PEND ACTLINK** An activate link command (ACTLINK) is in progress.
- | **ACTIVE** An ACTLINK has been processed, and the line is active.
- | **PEND DACTLNK** A deactivate link command (DACTLINK) is in progress.
- | **INACTIVE** A DACTLINK has been processed, and the line is inactive.
- | **FORCE DEACT** The line has been forced into deactivation. (A force deactivate command was issued from VTAM.)

PEND ANS

Line quiescence is pending due to automatic network shutdown (ANS).

MAXFRAME

Maximum frame size, in bytes, for this line as defined by the MAXFRAME keyword on the LINE statement.

DYNWIND(nw) (starting with NCP V7R1)

Number of frames that must be received and acknowledged by the adjacent device before the sending NCP increments the IEEE 802.2 LLC working window value. When the sending NCP receives acknowledgements for *nw* consecutive I-frames, the working window value is incremented until it reaches the value specified by MAXOUT for subarea connections, or the value specified in the VTAM switched major node for peripheral connections.

For NCP V7R1 and V7R2, the value in this field is defined by the *nw* suboperand of the DYNWIND keyword on the LINE statement for the physical frame-relay line. The *nw* value for the physical line applies to all logical lines and stations associated with it.

For NCP V7R3 or later releases, the value in this field is defined by the *nw* suboperand of the DYNWIND keyword on the LINE or (starting in NCP V7R5) PU statement for a physical frame-relay line. The value applies to all logical peripheral lines and stations associated with that physical line, except any peripheral station for which the DYNWIND(*nw*) value is defined in the VTAM switched major node.

DYNWIND(dw) (starting with NCP V7R1)

Value by which the sending NCP divides, or percentage by which the sending NCP reduces, the IEEE 802.2 LLC working window value when frame loss occurs. 1 is a special value which indicates that the working window value should be set to its minimum when frame loss is detected.

For NCP V7R1 and V7R2, the value in this field is defined by the *dw* suboperand of the DYNWIND keyword on the LINE statement for the physical frame-relay line. The value applies to all logical lines and stations associated with that physical line.

For NCP V7R3 or later releases, the value in this field is defined by the *dw* suboperand of the DYNWIND keyword on the LINE or (starting in NCP V7R5) PU statement for a physical frame-relay line. The value applies to all logical peripheral lines and stations associated with that physical line, except any peripheral station for which the DYNWIND(*dw*) value is defined in the VTAM switched major node.

DYNWIND(dwc) (starting with NCP V7R1)

Value by which the sending NCP divides, or percentage by which the sending NCP reduces, the IEEE 802.2 LLC working window value when BECN occurs. 1 is a special value which indicates that the working window value should be set to its minimum when BECN is indicated.

For NCP V7R1 or later releases, the value in this field is defined by the *dwc* suboperand of the DYNWIND keyword on the LINE or (starting in NCP V7R5) PU statement for a physical frame-relay line.

For NCP V7R1 and V7R2, the *dwc* value for the physical line applies to all logical lines and stations associated with that physical line.

For NCP V7R3 or later releases, the *dwc* value of the physical line applies to all logical peripheral lines and stations associated with that physical line,

except any peripheral station for which the DYNWIND(*dwc*) value is defined in the VTAM switched major node.

| **DYNWIND(*dwd*) (starting with NCP V7R5; not applicable to 3746 Model 900**
| **frame-relay physical lines)**

Upper bound for the I-frame delay, in seconds. Defined by the *dwdmax* suboperand of the DYNWIND keyword on the LINE or PU statement.

| **DYNWIND(*twc*) (starting with NCP V7R5; not applicable to 3746 Model 900**
| **frame-relay physical lines)**

YES or NO to specify whether NCP should ignore subsequent BECNs for 100 milliseconds after an initial BECN is received. Defined by the *twcuse* suboperand of the DYNWIND keyword on the LINE or PU statement.

| **DYNWIND(*mww*) (starting with NCP V7R8; not applicable to 3746 Model 900**
| **frame-relay physical lines)**

| Lower bound for the IEEE 802.2 LLC working window when the window is
| reduced for frame loss or BECNs. Defined by the *mww* suboperand of the
| DYNWIND keyword on the LINE or PU statement.

Physical Line Frame Statistics

The following fields show transmit and receive counts and changes to the transmit and receive rates. If a rate change is greater than one frame per second, the change is shown as a number of frames per second (*n/S*) in reverse-video yellow. If a change is less than one frame per second, the actual number of frames is shown.

Total Frames (not available for 3746 Model 900)

Number of frames transmitted and received over this line.

Total Retries (not available for 3746 Model 900)

Total number of retries for transmissions over this line.

I-Frame Retries (not available for 3746 Model 900)

Number of retries made to transmit I-frames over this line.

Frame Format Errors (not available for 3746 Model 900)

Number of I-frames with format errors received over this line.

Receive Errors (starting with NCP V7R5; not available for 3746 Model 900)

Number of consecutive "errors" received over this line, where an "error" is any 100-millisecond period in which NCP detects an error in the transmission received from the adjacent frame relay node.

CUR Current consecutive-error count.

THRESH Maximum number of consecutive "errors" (that is, error-containing 100-millisecond periods) that the line is to tolerate. Defined by the first (*m*) suboperand of the RETRIES keyword on the physical GROUP or LINE statement. If this number is exceeded, NCP will INOP the line. A displayed value of NONE indicates that this line will not be brought down regardless of the number of received errors.

Last PSA Error Status (not applicable for 3746 Model 900)

The last four abnormal trace entries in the Parameter Status Area (PSA) are displayed, in chronological order.

Local Mgmt Interface DLCI 0

The following fields show LMI information for this line.

Message area

The line above the LMI field may display one of the following messages:

Full Status MSG Outstanding

NCP has sent an LMI full status message to the adjacent node and is awaiting a response.

LIV Status MSG Outstanding

NCP has sent an LMI link integrity verification (LIV) status enquiry message to the adjacent node and is awaiting a response.

Note: No messages are displayed for 3746 Model 900.

LMI

LMI standard (CCITT, CCITT-NUI, ANSI, ANSI-NUI, or NO) and NCP echo detection mode (PRIMARY or SECONDARY) as defined by the LMI keyword on the PU statement. If echo detection is not defined for this line, NO ECHO is displayed.

Echo detection is only for the LMI interface (DLCI 0) between adjacent NCP frame-relay nodes communicating through a satellite connection.

Message area

The line below the LMI field displays a message to indicate whether LMI protocol is being used for the network or user side of the link.

This field may also display "LMI Activation Pending" to indicate that LMI communication over DLCI 0 to the adjacent frame-relay node is still pending. Verify that the LMI parameters at each end of the line are compatible; for example, if the adjacent node uses ANSI-standard LMI protocol, be sure that LMI=ANSI or LMI=ANSI-NUI is defined for this NCP.

Note: No messages are displayed for 3746 Model 900.

LVL 3 Discards (not applicable for 3746 Model 900)

Number of LMI frames received over DLCI 0 that were discarded by NCP level 3.

LVL 5 Discards (not applicable for 3746 Model 900)

Number of LMI frames discarded by NCP level 5 due to format errors.

PU Status

The status of the LMI PU, which will be one of the following:

INACTIVE	Reset
XID PEND	XID pending with data
XID NODT	XID pending without data
CONT PND	Contact pending
PENDING	Contact and discontact pending
ACTIVE	Active (normal data)
DISC PND	Discontact pending

The following fields show values for standard LMI variables for both the user side and the network side of this connection.

N391

Minimum frequency (number of T391 intervals) at which LMI Status Enquiry Full messages are sent over this line to the adjacent node, as defined by the SPOLL keyword on the PU statement. This value is displayed only for the user side of the line.

N392 (gen/cur)

N393

LMI error threshold at which NCP determines that communication with the adjacent frame-relay device has been lost as defined by the ERRORT keyword on the PU statement. This threshold is reached when *N392* LMI errors occur in *N393* consecutive LMI events. For N392, NTuneMON shows both the generated value and the current error count.

Note: Current error count for N392 is not available for 3746 Model 900.

T391

Interval, in seconds, between transmissions of LMI status enquiry messages as defined by the *t391* suboperand of the TIMERS keyword on the PU statement. T391 is used only on the user side of the line.

T392

Interval, in seconds, in which an LMI status enquiry message must be received before the time interval is considered an error interval. Defined by the *t392* suboperand of the TIMERS keyword on the PU statement. T392 is used only on the network side of the line.

SEND (not available for 3746 Model 900)

Current send sequence number for the user and network side of the line, shown in decimal and hexadecimal formats.

RCVD (not available for 3746 Model 900)

The current receive sequence number for the user and network side of the line, shown in decimal and hexadecimal formats.

Frame-Relay BAN Connection

Source Addr

Frame-relay BAN identifier as defined by the LOCADD keyword of the physical LINE statement. Displayed if one of the following conditions is met:

- Beginning with NCP V7R1, if the physical line is a 3745 line with associated peripheral resources, and LOCADD on the LINE statement is not zero
- Beginning with NCP V7R3, if the physical line is a CSS line with associated peripheral resources, and LOCADD on the LINE statement is not zero
- Beginning with NCP V7R5, if the physical line is a CSS line, and LOCADD on the LINE statement is not zero

If none of the above conditions is met, then the Source Addr field displays "N/A".

ISDN Backup Information (starting with NCP V7R6)

If ISDN backup is enabled for this frame-relay link, the bottom-right corner of the panel displays ISDN BACKUP ALLOWED. If ISDN backup is not enabled, it says NO ISDN BACKUP.

PF Keys**F1=HELP**

Displays online help for this panel.

F2=DLCI/SUBA

Displays the ATUFA Frame Relay Subport List panel, as shown on page 4-88, which shows all the DLCIs for this line. The subarea address is shown next to each SATESP DLCI.

F3=RTN

Returns to the previous NTuneMON panel.

F4=DLCI CIR (starting with NCP V7R7)

Displays the ATUFB Frame Relay DLCI CIR Parameters panel, as shown on page 4-92, which shows any DLCI committed information rate (CIR) values for this line.

F5=MODIF

Available when the operator has tuning authority and NTuneNCP is included. For more information, refer to Chapter 5, Using the NTuneNCP Tuning Feature.

Updates the NCP tuning parameter with the modified value. If the modification is not valid, the field turns reverse-video pink, and you are prompted to correct the value and resubmit it.

F6=ROLL

Returns to the NetView command line without exiting NTuneMON. To return to NTuneMON from the NetView program, press F6=ROLL or enter **ATUNEMON** on the NetView command line.

F7=BAL FA (starting with NCP V7R7)

Displays the ATUFD Frame Relay DLCI to Balance Table panel, as shown on page 4-99.

F8=FP PG 2 (starting with NCP V7R6)

Displays the ATUFP2 Frame Relay Details Page 2 panel, as shown on page 4-117.

F9=ISDN (starting with NCP V7R6)

Displays the ATUDL ISDN Physical Line Table panel, as shown on page 4-59, if the frame-relay line has ISDN backup assigned. If ISDN backup is not assigned, an error message is issued.

F10=HEX

Displays the ATUDP Hexadecimal Storage Display panel, as shown on page 4-68, to show the common physical unit block (CUB) for a 3745 line or the line control block (LKB) for a 3746 Model 900 line.

F11=FP PG 3 (starting with NCP V7R7; 3746 Model 900 only)

Displays the ATUFP3 Frame Relay Details Page 3 panel, as shown on page 4-122.

ATUFP Frame Relay Physical Line Details Page 1 Panel

F12=RFRSH

Refreshes the information on this panel.

ENTER=ONLY DLCIs

Displays the ATUFA Frame Relay Support List panel, as shown on page 4-88, which shows all the DLCIs for this line.

PA1=EXIT

Exits NTuneMON.

PA2=LOG

Saves the information on this panel to the NetView log.

ATUFP2 Frame Relay Details Page 2 Panel

Basic fast-path commands: None

Tuning fields: Priority, ANSTONE, RING, REDIAL

```

ATUFP2  A04SUP3  Frame Relay Details Page 2  NTuneMON V2R5  02:42
OWNERPL Function Active =  NO                      Elapsed Time =63

      Frame Information
Line Name= A04FL033  LEASED
Status =  INACTIVE                      DATABLK = 2048  MAXFRAME = 4096

      Priority  Max Size  Min Size  Number of  Estimated
                Frame Sent  Frame Sent  Frames Sent  Bytes Sent
-----
LINE  N/A      -         -         -         -
SNA   1         -         -         -         -
IP    1         -         -         -         -
FH    1         -         -         -         -

      SNA Only
ANSTONE = N/A      AUTO = N/A      V25BIS= NO
RING    = N/A      DIAL  = NO
REDIAL  = ( N/A , N/A , N/A , N/A )

=>
F1=HLP F2=VERIFY F3=RTN F4=RESET MIN/ F5=MODIF F6=ROLL F7=FP PG 1
ENTER=ONLY DLCIS          F10=HEX F12=RFRSH/RATES PA1=EXIT PA2=LOG
    
```

Figure 4-35. ATUFP2 Frame Relay Details Page 2 Panel

Description

The ATUFP2 Frame Relay Details Page 2 panel, which is available starting with NCP V7R6, displays detailed information for a single frame-relay physical line.

To display this panel:

- On the ATUFP Frame Relay Physical Line Details Page 1 panel, as shown on page 4-108, press F8.
- On the ATUFP3 Frame Relay Details Page 3 panel, as shown on page 4-122, press F7.

Fields

NCP name (second field on panel)

Name of the NCP that is currently displayed.

OWNERPL Function Active

Whether the OWNERPL function is active:

- YES** The frame-relay unassigned logical resources (PHYSRSC=NONE) are being allocated to this physical line based on common SSCP ownership of the physical and logical resources. (This line’s resource type, FR or ODLCFR, was specified on the OWNERPL keyword on the BUILD statement.)
- NO** The OWNERPL function is not active. (The OWNERPL keyword was not coded on the BUILD statement; or this line’s resource type, FR or ODLCFR, was not specified on the OWNERPL keyword.)

Elapsed Time

The amount of time that has passed from panel entry until the panel is refreshed, or the amount of time that has passed since the statistics were last refreshed.

Frame Information

This section of the panel displays frame information for this frame-relay physical line and associated protocols as represented by frame-relay physical stations.

Line information

The name of the line and whether it is switched (DIAL=YES) or leased (DIAL=NO), as defined by the DIAL keyword on the GROUP statement.

Status

Physical line status: ACTIVE or INACTIVE.

DATABLK (3745 frame relay only)

Minimum guaranteed transmission bandwidth (in bytes) that can be allocated to a protocol, as defined by the DATABLK keyword on the LINE statement. The DATABLK keyword is used with the *priority* suboperands of the FRRATES keyword on the LINE statement to determine relative priorities among protocols. The value of *priority* is multiplied by the value of DATABLK to determine the guaranteed minimum number of bytes that a protocol can transmit before a different protocol must be given a transmission priority.

MAXFRAME

Maximum size, in bytes, for frames that can be transmitted or received over the physical line for a frame-relay interface. Defined by the MAXFRAME keyword of the physical LINE statement.

Priority (3745 frame relay only)

Relative communications rate priority for each protocol (SNA, IP, or frame handler) when supported by a 3745 frame-relay physical line. Defined by that protocol's *priority* suboperand of the FRRATES keyword on the LINE statement. *priority* is multiplied by the value of the DATABLK keyword on the LINE statement to determine the guaranteed minimum number of bytes that the protocol can transmit before a different protocol must be given a transmission opportunity.

NTuneMON displays "N/A" for the frame-relay physical line because it has no associated *priority* value under FRRATES.

Max Size Frame Sent (3745 frame relay only)

Maximum size frame (in bytes) sent by this line or protocol (SNA, IP, or frame handler) since the last time this field was reset by NTuneMON. When you reset this field by selecting the line or a protocol with your cursor and pressing F4, NTuneMON automatically refreshes the panel and displays the new traffic rate if it is available. Otherwise, NTuneMON displays a dash (–) until the new traffic rate is available and you press F12 or reenter the panel to display the new rate.

Note: Set the NTUNECOL keyword on the BUILD definition statement to YES to allow this data to be collected and displayed.

Min Size Frame Sent (3745 frame relay only)

Minimum size frame (in bytes) sent by this line or protocol (SNA, IP, or frame handler) since the last time this field was reset by NTuneMON. When you reset this field by selecting the line or a protocol with your cursor and pressing

F4, NTuneMON automatically refreshes the panel and displays the new traffic rate if it is available. Otherwise, NTuneMON displays a dash (–) until the new traffic rate is available and you press F12 or reenter the panel to display the new rate.

Note: Set the NTUNECOL keyword on the BUILD definition statement to YES to allow this data to be collected and displayed.

Number of Frames Sent (3745 frame relay only)

Number of frames sent by this line or protocol (SNA, IP, or frame handler). When this panel is entered, it displays the number of frames. When F12 is pressed, the panel displays frames per second (*n/Sec*).

Notes:

1. The number of frames for the line might not equal the sum of the frames for all of the specified protocols.
2. Set the NTUNECOL keyword on the BUILD definition statement to YES to allow this data to be collected and displayed.

Estimated Bytes Sent (3745 frame relay only)

Estimated bytes per second (*n/SEC*) sent by this line or protocol (SNA, IP, or frame handler). The number of bytes is estimated by taking the average of the maximum size frame sent and the minimum size frame sent. To get a more current estimate, press F4 to reset the Max Size Frame Sent and Min Size Frame Sent fields. NTuneMON resets the fields and automatically refreshes the panel. If new traffic rates are available, they are displayed. Otherwise, a dash (–) is displayed until new traffic rates are available and you press F12 to refresh the traffic rates.

Note: Set the NTUNECOL keyword on the BUILD definition statement to YES to allow this data to be collected and displayed.

ANSTONE

Whether NCP transmits an answer tone to the calling device to signify completion of the line connection, as defined by the ANSTONE keyword on the LINE statement. Used only for incoming calls on switched lines.

RING

Whether the ring-indicator mode of an automatic answer operation is used, as defined by the RING keyword on the LINE statement. This decision depends upon the type of modem (data set) that connects the link to the controller.

REDIAL(m, t1, n, t2)

The timing and maximum number of dialing operations NCP performs in attempting to reach a device over a switched line. Defined by the REDIAL keyword on the LINE statement. NCP performs dialing operations in sequences, with a pause between dialing operations in each sequence and a pause between sequences.

AUTO

Whether there is an automatic calling unit (ACU) on the line, as defined by the AUTO keyword on the LINE statement. AUTO is normally used when the callout operation is performed.

DIAL

Whether the line is switched (DIAL=YES) or leased (DIAL=NO), as defined by the DIAL keyword on the GROUP statement.

V25BIS

Whether the modem for the line supports the V.25 bis protocol and which line protocol is used for the dial connection, as defined by the V25BIS keyword on the LINE statement.

PF Keys

F1=HLP

Displays online help for this panel.

F2=VERIFY

Available when the operator has tuning authority and NTuneNCP is included.

Verifies that the tunable dial-related parameters near the bottom of the panel are within range and consistent with each other. Changes that are either not in range or not consistent are highlighted in reverse-video pink and are recorded in the NetView log. No changes are sent to NCP with this key. Use F5 to send changes.

F3=RTN

Returns to the previous NTuneMON panel.

F4=RESET MIN/MAX

Available when the operator has tuning authority and NTuneNCP is included. For more information, refer to Chapter 5, Using the NTuneNCP Tuning Feature.

Resets the values of the Max Size Frame Sent and Min Size Frame Sent fields. After resetting the fields, NTuneMON automatically refreshes the panel. If new traffic rates are available, they are displayed. Otherwise, NTuneMON displays a dash (–) until new traffic rates are available and you press F12 or reenter the panel to display the new rates. To reset these fields, place the cursor under the line or protocol you want and press F4.

F5=MODIFY

Available when the operator has tuning authority and NTuneNCP is included. For more information, refer to Chapter 5, Using the NTuneNCP Tuning Feature.

Updates the NCP tuning parameter with the modified value. If the modification is not valid, the field turns reverse-video pink, and you are prompted to correct the value and resubmit it.

F6=ROLL

Returns to the NetView command line without exiting NTuneMON. To return to NTuneMON from the NetView program, press F6=ROLL or enter **ATUNEMON** on the NetView command line.

F7=FP PG 1

Scrolls back to the ATUFP Frame Relay Physical Line Details Page 1 panel, as shown on page 4-108.

F8=FP PG 3 (starting with NCP V7R7; 3746 Model 900 only)

Scrolls forward to the ATUFP3 Frame Relay Details Page 3 panel as shown on page 4-122.

ENTER=ONLY DLCIs

Displays the ATUFA Frame Relay Subport List panel, as shown on page 4-88, which shows all the DLCIs for this line.

|
|
|
F9=BAL FACT (starting with NCP V7R7)

Displays the ATUFD Frame Relay DLCI to Balance Table panel, as shown on page 4-99.

F10=HEX

Displays the ATUDP Hexadecimal Storage Display panel, as shown on page 4-68, to show the common physical unit block (CUB) for the 3745 line.

F12=REFRESH/TRAFFIC RATES

Refreshes the information on this panel and displays traffic rates.

PA1=EXIT

Exits NTuneMON.

PA2=LOG

Saves the information on this panel to the NetView log.

ATUFP3 Frame Relay Details Page 3 Panel

Basic fast-path commands: None

Tuning fields: FRSPRI, HLOQSTOP, QSIZEDE, QSIZE, CRATEDLY, DSCRDDLY, CIR, PRECISION, MIR Per, CLLM, Ty, PER

```

ATUFP3  A04C901  Frame Relay Details Page 3  NTuneMON V2R5  13:15

  Line Addr = 2336      Line Type = CLP  Full Duplex
  Line Name = A04FRL36  Status = INACTIVE
  LEASED      DATABLK = N/A
*****
FRSPRI      = 0
*****
HLOQSTOP    = DEFAULT      CRATEDLY = DEFAULT
QSIZEDE     = DEFAULT      DSCRDDLY = DEFAULT
QSIZE       = DEFAULT
*****
CIR         = YES          CLLM      = NO
PRECISION   = 7            Ty         = 11
MIR Per     = 25           PER       = DEFAULT

=>
F1=HLP  F3=RTN  F5=MODIFY  F6=ROLL  F7=FP PG 2  F8=FP PG 1
ENTER=ONLY DLCIs  F11=DLCI CIR  F10=HEX  F12=REFRESH  PA1=EXIT  PA2=LOG
    
```

Figure 4-36. ATUFP3 Frame Relay Details Page 3 Panel

Description

The ATUFP3 Frame Relay Details Page 3 panel, which is available starting with NCP V7R7, displays detailed information for a single 3746 Model 900 attached frame-relay physical line.

To display this panel:

- From the ATUFP Frame Relay Physical Line Details Page 1 panel, as shown on page 4-108, press F11 when 3746 Model 900 information is being displayed.
- From the ATUFP2 Frame Relay Details Page 2 panel, as shown on page 4-117, press F8 when 3746 Model 900 information is being displayed.

Fields

NCP name (second field on panel)

Name of the NCP that is currently displayed.

Line Addr

Address of this line as defined by the ADDRESS keyword on the LINE statement.

Line Name

Name of this line. This name is the label on the LINE statement.

Dial information

SWITCHED or LEASED, to indicate whether the line is switched (DIAL=YES) or leased (DIAL=NO), as defined by the DIAL keyword on the GROUP statement.

Line Type

- Line adapter type: CLP (communication line processor)
- Line type: Full Duplex or Half Duplex

Status

Physical line status: ACTIVE or INACTIVE

DATABLK

Minimum guaranteed transmission bandwidth (in bytes) that can be allocated to a protocol, as defined by the DATABLK keyword on the LINE statement. The DATABLK keyword is used with the HLOQSTOP, QSIZEDE, and QSIZE keywords to determine the 3746 Model 900 CLP frame-relay congestion control parameters.

FRSPRI

A relative service priority at a station level, as defined by the FRSPRI keyword on the LINE statement.

Notes about the Following Queue Congestion Control Fields (HLOQSTOP, QSIZEDE, QSIZE, CRATEDLY, and DSCRDDL):

1. If these fields display DEFAULT, then the values for these fields are provided by the 3746 Model 900.
2. If you modify DEFAULT with your own value in any of these fields, then you must specify values for all of these fields.

HLOQSTOP

The threshold that determines the maximum number of bytes that can be queued to the 3746 Model 900 attached frame-relay physical line's hardware queue before a 3746 Model 900 software queue is created for the physical line. Defined by the HLOQSTOP keyword on the LINE statement. The value displayed in this field is multiplied by the DATABLK value to determine the threshold in bytes.

If this field displays DEFAULT, then the value for this field is provided by the 3746 Model 900.

QSIZEDE

The 3746 Model 900 software queue threshold which, when it is reached, triggers the discarding of the last frames received with the Discard Eligible (DE) indicator set to binary 1. Defined by the QSIZEDE keyword on the LINE statement. The value displayed in this field is multiplied by the DATABLK value to determine the threshold in bytes.

If this field displays DEFAULT, then the value for this field is provided by the 3746 Model 900.

QSIZE

The 3746 Model 900 software queue threshold which, when it is reached, triggers the discarding of all the last frames received regardless of how the Discard Eligible (DE) indicator is set. Defined by the QSIZE keyword on the LINE statement. The value displayed in this field is multiplied by the DATABLK value to determine the threshold in bytes.

If this field displays DEFAULT, then the value for this field is provided by the 3746 Model 900.

CRATEDLY

A threshold for a minimum time on the 3746 Model 900 software queue, used by the 3746 in conjunction with the DSCRDDLY and COMRATE values to trigger congestion controls (discarding of the frame or setting of the FECN indicator) under certain conditions.

If the frame has been on the software queue in excess of the amount of time specified by CRATEDLY but less than the amount of time specified by DSCRDDLY, then the following action will be taken:

- If more than 100% of the station's COMRATE has been used, then the frame will be discarded.
- If more than 75% but less than or equal to 100% of the station's COMRATE has been used, then the frame will be transmitted with the FECN indicator set to binary 1.
- If less than 75% of the station's COMRATE has been used, then the frame will be transmitted.

The value in this field is defined by the CRATEDLY keyword on the LINE statement.

If this field displays DEFAULT, then the value for this field is provided by the 3746 Model 900.

DSCRDDLY

A threshold for a maximum time on the 3746 Model 900 software queue, used by the 3746 in conjunction with the CRATEDLY and COMRATE values to trigger congestion controls (discarding of the frame or setting of the FECN indicator) under certain conditions. Defined by the DSCRDDLY keyword on the LINE statement.

If this field displays DEFAULT, then the value for this field is provided by the 3746 Model 900.

CIR Information

CIR

Whether the committed information rate (CIR) algorithms are used for bandwidth management, as specified by the CIR keyword on the LINE statement.

PRECISION

An integer used to determine the adaption speed of the CIR adaptive algorithm. Specified by the *precision* parameter of the CIR keyword on the LINE statement.

MIR Per

An integer used to determine the minimum information rate that the CIR adaptive algorithm can reach for a DLCI. Specified by the *mir%* parameter of the CIR keyword on the LINE statement.

CLLM

Whether Consolidated Link Layer Management (CLLM) will be used. Specified by the CLLM keyword on the LINE statement.

Ty

The interval, in seconds, used by the Ty timer to determine when the congestion or outage condition has cleared. Specified by the *Ty* parameter of the CLLM keyword on the LINE statement.

PER

The interval, in seconds, used by the CIR adaptive algorithm to determine the CIR. Specified by the *period* parameter of the CIR keyword on the LINE statement.

PF Keys**F1=HLP**

Displays online help for this panel.

F3=RTN

Returns to the previous NTuneMON panel.

F5=MODIFY

Available when the operator has tuning authority and NTuneNCP is included. For more information, refer to Chapter 5, Using the NTuneNCP Tuning Feature.

Updates the NCP tuning parameter with the modified value. If the modification is not valid, the field turns reverse-video pink, and you are prompted to correct the value and resubmit it.

F6=ROLL

Returns to the NetView command line without exiting NTuneMON. To return to NTuneMON from the NetView program, press F6=ROLL or enter **ATUNEMON** on the NetView command line.

F7=FP PG 2

Scrolls back to the ATUFP2 Frame Relay Details Page 2 panel, as shown on page 4-117.

F8=FP PG 1

Scrolls back to the ATUFP Frame Relay Physical Line Details Page 1 panel, as shown on page 4-108

ENTER=ONLY DLCIs

Displays the ATUFA Frame Relay Support List panel, as shown on page 4-88, which shows all the DLCIs for this line.

F9=DEFAULT

Resets the HLOQSTOP, QSIZEDE, QSIZE, CRATEDLY, and DSCRDDLY fields to DEFAULT, which means that future values for these fields will be provided by the 3746 Model 900.

F10=HEX

Displays the ATUDP Hexadecimal Storage Display panel, as shown on page 4-68, to show the line control block (LKB) for the 3746 Model 900 line.

F11=DLCI CIR

Available when DLCIs are genned and CIR=YES. Displays the ATUFB Frame Relay DLCI CIR Parameters panel, as shown on page 4-92, which shows any DLCI committed information rate (CIR) values for this line.

F12=REFRESH

Refreshes the information on this panel.

PA1=EXIT

Exits NTuneMON.

PA2=LOG

Saves the information on this panel to the NetView log.

detailed information on the frame-relay physical line. For a NTRI frame handler logical line, this field displays NONE.

LINE NAME

Names of the frame-relay physical lines or the NTRI frame handler logical lines. These names are the labels on the LINE statements and are displayed above the PU name. When a line is not active, this field is highlighted in reverse-video red.

PU NAME

Names of the PUs associated with the DLCIs. These names are the labels on the PU statements. When a PU is not active, this field is highlighted in reverse-video red.

COMRATE (NCP V7R2 or later releases)

Relative transmit priority for an FHSP as defined by the *priority* suboperand of the COMRATE keyword on the PU statement. *Priority* is multiplied by the value of the DATBLK keyword on the LINE statement to determine the guaranteed minimum number of bytes that an FHSP can transmit before a different FHSP must be given a transmission opportunity.

DLCI

The DLCIs associated with this FHSP, shown in decimal and hexadecimal formats. Defined by the ADDR or DLCI keyword on the PU statement.

MAXFRAME

Maximum frame size, in bytes, for this frame-relay physical line or NTRI frame handler logical line as defined by the MAXFRAME keyword on the LINE statement.

BUF SIZE

NCP buffer size as defined by the BFRS keyword on the BUILD statement.

SERVICE PRI (starting with NCP V7R7; 3746 Model 900 only)

A relative service priority, at a station level, for the diagrammed 3746 Model 900 attached frame-relay switching equipment. Defined by the FRSPRI keyword on the PU statement. If this field displays N/A, then secondary subports are not defined for this resource.

Diagram of FHSPs

The diagram on the panel shows the active and inactive routes (PVC segments) for a single PVC going through this NCP. It shows the following items:

- Primary FHSPs (P1 and P2) and optional substitute subports (S1 and S2), if defined.
- Internal routes connecting the NCP FHSPs.
- External routes between the NCP FHSPs and the adjacent frame-relay nodes.

The active route is highlighted in reverse-video green, and inactive routes are highlighted in pink. The names of inactive subports are highlighted in reverse-video red.

The routes through the subport set are indicated by the following types of arrows. The direction of an arrow indicates the direction of data flow.

<=====>

Permanent virtual circuit (PVC) segment within NCP between subports in an active route.

<- . ->

PVC segment within NCP between two subports in an inactive route. If one of the subports for active route fails, an inactive route can take over if both of its subports are active.

<====>

PVC segment between a subport and an adjacent frame-relay node over a DLCI that is active in both directions and is part of the active route.

<--- or --->

Active PVC segment between an NCP subport and an adjacent frame-relay node in an inactive route. The direction of the arrow indicates the direction in which the DLCI is active. If there are two of these arrows, one in each direction, between a subport and an adjacent node, the PVC segment can take over if the corresponding PVC segment in the active route becomes unavailable.

<-. - or -. ->

PVC segment that is inactive or of unknown status between an NCP subport and an adjacent frame-relay node. This type of arrow is highlighted in reverse-video red. An arrow pointing toward the NCP subport indicates that NCP is reporting the DLCI as inactive. An arrow pointing toward the DLCI indicates that the adjacent station is reporting the DLCI as inactive.

<-X- or -X-> **(not available for 3746 Model 900)**

PVC segment between an NCP subport and an adjacent frame-relay node that is unavailable because the DLCI is not defined to the adjacent node. An arrow pointing toward the NCP subport indicates that NCP is reporting the DLCI as undefined. An arrow pointing toward the DLCI indicates that the adjacent station is reporting the DLCI as undefined. To check the LMI status of the physical line, place the cursor under the address (LINE ADDR field) and press the Enter key.

FRSESET SUBPORTS

Names of the primary and optional substitute subports, as defined by the SUBPORTS keyword on the FRSESET statement.

PF Keys

F1=HELP

Displays online help for this panel.

F3=RETURN

Returns to the previous NTuneMON panel.

F5=MODIFY

Available when the operator has tuning authority and NTuneNCP is included. For more information, refer to Chapter 5, Using the NTuneNCP Tuning Feature.

Updates the NCP tuning parameter with the modified value. If the modification is not valid, the field turns reverse-video pink, and you are prompted to correct the value and resubmit it.

F6=ROLL

Returns to the NetView command line without exiting NTuneMON. To return to NTuneMON from the NetView program, press F6=ROLL or enter **ATUNEMON** on the NetView command line.

F8=FORWARD (if FRSEs are active)

Scrolls forward to the ATUFS2 Frame Relay Switching Equipment Page 2 panel as shown on page 4-131.

F10=HEX

Displays the ATUDP Hexadecimal Storage Display panel, as shown on page 4-68, to show the common physical unit block (CUB) for the FHSP. Place the cursor under the address of the line (LINE ADDR field) and press F10.

F12=REFRESH/RATES

Refreshes the information on this panel.

ENTER=LINE DETAILS

Displays one of the following panels:

- When the cursor is under the LINE ADDR field for a frame-relay physical line and you press Enter, the ATUFP Frame Relay Physical Line Details Page 1 panel, as shown on page 4-108, is displayed. This panel shows detailed information on the line.
- When the cursor is under the LINE ADDR field for a NTRI frame handler logical line and you press Enter, the ATUTD NTRI Frame Handlers Logical Line Details panel, as shown on page 4-285, is displayed. This panel shows detailed information on the line.

Place the cursor under the LINE ADDR field for the line you want to view and press Enter.

PA1=EXIT

Exits NTuneMON.

PA2=LOG

Saves the information on this panel to the NetView log.

ATUFS2 Frame Relay Switching Equipment Page 2 Panel

Basic fast-path commands: None

Tuning fields: None

```

ATUFS2 A71NT06 Frame Relay Switching Equipment Page 2 NTuneMON V2R1 15:51
                                     MAXFRAME = 8000
                                     BUF SIZE = 240
-----
                                NCP FRSE Outbound Buffer Queues
                                *-----* *-----* 0 = QUEUE
                                <---| P1 | | P2 |---> 275 = LIMIT
                                *-----* *-----* 8 = MAXOUT
                                *-----* *-----* 8 = MAXOUT

                                DLCI = 16(010)                                16(010) = DLCI
                                BECNs Set = 0                                0 = BECNs Set
                                FECNs Set = 0                                0 = FECNs Set
                                DE Bits Set = 0                            0 = DE Bits Set
                                Bytes/Sec = 1.1/Sec                        1.1/Sec = Bytes/Sec
                                Frames Sent = 4                            4 = Frames Sent
                                Frames Discarded = 0                      0 = Frames Discarded
                                Max Size Frame Sent = 85                  85 = Max Size Frame Sent
                                Min Size Frame Sent = 15                  15 = Min Size Frame Sent
                                COMRATE Priority = 1                      1 = COMRATE Priority

=>
F1=HELP 3=RETURN F4=RESET MIN/MAX F6=ROLL F7=BACK 12=REFRESH/RATES
PA1=EXIT PA2=LOG
    
```

Figure 4-38. ATUFS2 Frame Relay Switching Equipment Page 2 Panel

Description

The ATUFS2 Frame Relay Switching Equipment Page 2 panel, which is available for NCP V6R2 or later releases, provides information on NCP FRSE, including statistics for the processing of frames through the NCP FHSPs.

To display this panel: On the ATUFS1 Frame Relay Switching Equipment Page 1 panel, as shown on page 4-127, press F8.

For more information on defining FHSPs and the routes going through them, refer to *NCP, SSP, and EP Resource Definition Guide*.

Fields

NCP name (second field on panel)

Name of the NCP that is currently displayed.

MAXFRAME

Maximum frame size, in bytes, for this frame-relay physical line or NTRI frame handler logical line as defined by the MAXFRAME keyword on the LINE statement.

BUF SIZE

NCP buffer size as defined by the BFRS keyword on the BUILD statement.

NCP FRSE Outbound Buffer Queues

The lower diagram on the panel shows the outbound queues associated with the subports in the active route

QUEUE (not available for IBM 3746 Model 900)

Number of NCP buffers currently filled by frames in the outbound queue. This value is highlighted as follows:

- If this number is greater than zero, it is highlighted in reverse-video yellow.
- If this number reaches one-half the value of LIMIT, it is highlighted in reverse-video pink. When this happens, NCP sends BECN and FECN indicators to reduce traffic.
- If this number reaches the value of LIMIT, it is highlighted in reverse-video red. When this happens, NCP discards arriving frames. Frames with the discard-eligible (DE) indicator are discarded before frames without the DE indicator.

The approximate number of frames in the queue is the QUEUE value times the NCP buffer size (the BFRS keyword on the BUILD statement) divided by the value of the MAXFRAME keyword on the LINE statement. The actual number of frames may be greater than this value for frames smaller than MAXFRAME.

LIMIT (not available for IBM 3746 Model 900)

Maximum number of NCP buffers that can be filled by frames on the outbound queue (the congestion limit). This value is equal to:

$$((\text{MAXOUT} \times \text{MAXFRAME})/\text{BFRS}) + \text{MAXOUT}$$

When the number of buffers reaches one-half the congestion limit (the congestion threshold), NCP sends congestion indicators to reduce traffic. When the number of buffers reaches the congestion limit, NCP discards all incoming frames.

MAXOUT (not available for 3746 Model 900)

Maximum number of maximum-sized frames NCP can place in the outbound queue for the PU, as defined by the MAXOUT keyword on the PU statement. The maximum frame size is defined by the MAXFRAME keyword on the PU statement.

DLCI

The DLCIs associated with this FHSP, shown in decimal and hexadecimal formats. Defined by the DLCI keyword or the ADDR keyword on the PU statement.

BECNs Set (starting with NCP V7R3; not available for 3746 Model 900)

Number of times that BECNs were set on in frames sent by this FHSP.

Note: Set the NTUNECOL keyword on the BUILD definition statement to YES to allow this data to be collected and displayed.

FECNs Set (starting with NCP V7R3; not available for 3746 Model 900)

Number of times that FECNs were set on in frames sent by this FHSP.

Note: Set the NTUNECOL keyword on the BUILD definition statement to YES to allow this data to be collected and displayed.

DE Bits Set (starting with NCP V7R3; not available for 3746 Model 900)

Number of times that discard-eligible (DE) bits were set on in frames sent by this FHSP.

Note: Set the NTUNECOL keyword on the BUILD definition statement to YES to allow this data to be collected and displayed.

Bytes/Sec (starting with NCP V7R3; not available for 3746 Model 900)

Estimated bytes per second (*n/SEC*) sent by this FHSP. The number of bytes are estimated by taking the average of the maximum size frame sent and the minimum size frame sent. To get a more current estimate, press F4 to reset the Max Size Frame Sent and the Min Size Frame Sent fields. NTuneMON resets the fields and automatically refreshes the panel. If new traffic rates are available, they are displayed. Otherwise, a dash (–) is displayed until new traffic rates are available and you press F12 to refresh the traffic rates.

Note: Set the NTUNECOL keyword on the BUILD definition statement to YES to allow this data to be collected and displayed.

Frames Sent (starting with NCP V7R3; not available for 3746 Model 900)

Number of frames sent by this FHSP. When this panel is entered, displays the number of frames. When F12 is pressed, displays the number of frames sent since the last refresh.

Note: Set the NTUNECOL keyword on the BUILD definition statement to YES to allow this data to be collected and displayed.

Frames Discarded (starting with NCP V7R3; not available for 3746 Model 900)

Number of frames discarded by this FHSP.

Note: Set the NTUNECOL keyword on the BUILD definition statement to YES to allow this data to be collected and displayed.

Max Size Frame Sent (starting with NCP V7R3; not available for 3746 Model 900)

Maximum size frame (in bytes) sent by this FHSP since the last time this field was reset by NTuneMON. When you reset this field by pressing F4, NTuneMON automatically refreshes the panel and displays the new traffic rate if it is available. Otherwise, NTuneMON displays a dash (–) until the new traffic rate is available and you press F12 or reenter the panel to display the new rate.

Note: Set the NTUNECOL keyword on the BUILD definition statement to YES to allow this data to be collected and displayed.

Min Size Frame Sent (starting with NCP V7R3; not available for 3746 Model 900)

Minimum size frame (in bytes) sent by this FHSP since the last time this field was reset by NTuneMON. When you reset this field by pressing F4, NTuneMON automatically refreshes the panel and displays the new traffic rate if it is available. Otherwise, NTuneMON displays a dash (–) until the new traffic rate is available and you press F12 or reenter the panel to display the new rate.

Note: Set the NTUNECOL keyword on the BUILD definition statement to YES to allow this data to be collected and displayed.

COMRATE Priority (NCP V7R2 or later releases)

Relative transmit priority for an FHSP as defined by the *priority* suboperand of the COMRATE keyword on the PU statement.

Priority is multiplied by the value of the DATABLK keyword on the LINE statement to determine the guaranteed minimum number of bytes that an FHSP can transmit before a different FHSP must be given a transmission opportunity.

PF Keys

F1=HELP

Displays online help for this panel.

F3=RETURN

Returns to the previous NTuneMON panel.

F4=RESET MIN/MAX (starting with NCP V7R3; not available for 3746 Model 900)

Available when the operator has tuning authority and NTuneNCP is included. For more information, refer to Chapter 5, Using the NTuneNCP Tuning Feature.

Resets the values of the Max Size Frame Sent and Min Size Frame Sent fields. After resetting the fields, NTuneMON automatically refreshes the panel. If new traffic rates are available, they are displayed. Otherwise, NTuneMON displays a dash (-) until new traffic rates are available and you press F12 or reenter the panel to display the new rates.

F6=ROLL

Returns to the NetView command line without exiting NTuneMON. To return to NTuneMON from the NetView program, press F6=ROLL or enter **ATUNEMON** on the NetView command line.

F7=BACK

Scrolls back to ATUFS1 Frame Relay Switching Equipment Page 1 as shown on page 4-127.

F12=REFRESH/RATES

Refreshes the information on this panel.

PA1=EXIT

Exits NTuneMON.

PA2=LOG

Saves the information on this panel to the NetView log.

ATUFT1 Frame Relay Terminating Equipment Details Page 1 Panel

Basic fast-path commands: None.

Tuning fields: COMRATE, DYNWIND(nw), DYNWIND(dw), DYNWIND(dwc), DYNWIND(dwd), DYNWIND(twc), CONGESTION, STATION, T1 TIMER, T2 TIMER, N3GEN, #PIUs/block, MAXDATA GEN, MAXOUT GEN, BLOCK GEN, PIUCHECK GEN, MimWW GEN, SERVICE PRIORITY

```

ATUFT1 A04D1 Frame Relay Terminating NTuneMON V2R6 12:44
Equipment Details Page 1 LLC Status: Link Opened
DLCI = 17(11) T1 Timer = 20.0
Line Name = J00041FF DYNWIND(nw) = 4 T2 Timer(1) = 0.0
Line Status= ACTIVE DYNWIND(dw) = 75 N3GEN = -
PU Name = J0004200 DYNWIND(dwc) = 25 #PIUs/block = N/A
COMRATE = ( FULL , 1 ) DYNWIND(dwd) = 5 DYNWIND(twc)= YES
CONGESTION = N/A STATION = N/A MODE = N/A

NCP Physical Line DESTINATION STATION Peripheral Node
Line Addr = 34 TSS IDBLK-IDNUM= 017-01285 DSAP = 14
PORTADD = 34 ACTIVE CPNAME = - TG = N/A
MAXFRAME = 4096 PU Status = ACTIVE SUBAREA = N/A
NETID= N/A

CUR: GEN:
MAXDATA = 265 265
MAXOUT = 3 3
BLOCK = N/A N/A
PIUCHECK= N/A N/A
MimWW = 3 8

FRAME RELAY BAN CONNECTION
Destination Address = N/A
SERVICE PRIORITY = N/A

=>
F1=HELP F3=RETURN F5=MODIFY F6=ROLL F8=FORWARD F10=HEX F12=REFRESH
ENTER=TG DETAILS PA1=EXIT PA2=LOG
    
```

Figure 4-39. ATUFT1 Frame Relay Terminating Equipment Details Page 1 Panel

Description

The ATUFT1 Frame Relay Terminating Equipment Details Page 1 panel, which is available for NCP V6R2 or later releases, displays information on the logical line associated with a particular DLCI.

To display this panel:

- On the ATUFA Frame Relay Support List panel, as shown on page 4-88, place the cursor under a TESP DLCI and press Enter.
- From the ATUFT2 Frame Relay Terminating Equipment Details Page 2 panel, as shown on page 4-143, press F7.

Fields

NCP name (second field on panel)

Name of the NCP that is currently displayed.

LLC Status (not available for 3746 Model 900)

Status of the type 2 logical line as defined by IEEE 802.2 LLC:

Logical Link Closed

The link is no longer active. Although the information displayed represents an inactive station, the information may be used to resolve problems with unsuccessful dial-in attempts.

XID Response Pending NCP is waiting for the XID response.

FRMR Sent A frame reject was sent.

FRMR Received A frame reject was received.

INOP in Progress The link is attempting to recover from an error.

Link Opening The link is being opened.

Link Opened The link is open for communications.

Link Clearing The link is being cleared.

Link Disconnecting The link is being disconnected.

Link Disconnected The link is disconnected.

LL2 ACT Link-level 2 active

LL2 PND Link-level 2 pending

DLCI

DLCI associated with this logical line, shown in decimal and hexadecimal formats. Defined by the ADDR or DLCI keyword on the PU statement.

Line Name

Name of the logical line.

Line Status

Status of this logical line. This can be any of the following:

PEND ACTLINK An activate link command (ACTLINK) is in progress.

ACTIVE An ACTLINK has been processed, and the line is active.

PEND DACTLNK A deactivate link command (DACTLINK) is in progress.

INACTIVE A DACTLINK has been processed, and the line is inactive.

FORCE DEACT The line has been forced into deactivation. (A force deactivate command was issued from VTAM.)

PEND ANS Line quiescence is pending due to ANS.

PU Name

Name of the PU associated with this DLCI. This name is the label on the PU statement.

COMRATE (FULL|NONE,priority)

Whether certain frames sent by this TESP can be discarded by the frame-relay network to expedite the processing of other frames when the network is congested. It also specifies the relative transmit priority for a TESP.

Defined by the COMRATE keyword on the LINE and PU statements.

COMRATE FULL|NONE

Status of the discard-eligible (DE) indicator for this TESP as defined by the FULL|NONE suboperand of the COMRATE keyword on the LINE statement. FULL indicates that frames sent by this TESP are not discard-eligible. NONE indicates that all frames sent by this TESP are discard-eligible except for the following types:

- XIDs
- Network priority frames (virtual route pacing and TG sweep)

- S frames (RR, RNR, and REJ), including RRs piggybacked on I-frames

Discard-eligible frames are discarded before non-discard-eligible frames to relieve severe network congestion.

COMRATE priority (NCP V7R2 or later releases)

Relative transmit priority for a TESP as defined by the *priority* suboperand of the COMRATE keyword on the PU statement. *Priority* is multiplied by the value of the DATABLK keyword on the LINE statement to determine the guaranteed minimum number of bytes that a TESP can transmit before a different TESP must be given a transmission opportunity.

CONGESTION (starting with NCP V7R6)

The station's role in congestion relief as defined by the third parameter of the TGCONF keyword on the PU definition statement:

- If the station can be used to relieve congestion, this field displays the station's threshold percentage.
- If the station can be used as a standby station but not to relieve congestion, this field displays NONE.
- If the station cannot be used as a standby station, this field displays N/A.

TGCONF (starting with NCP V7R6)

Value (MULTI or SINGLE) that you coded as the first parameter of the TGCONF keyword on the PU statement. This value affects the modifiability of the CONGESTION and STATION fields. (See the "Valid Values" sections in the Chapter 6 tuning information for the CONGESTION and STATION fields on the ATUFT1 panel.) If you omitted the first parameter of TGCONF, this field does not appear.

DYNWIND(nw) (starting with NCP V7R1)

Number of frames that must be received and acknowledged by the adjacent device before the sending NCP increases the IEEE 802.2 LLC working window value. When the sending NCP receives acknowledgements for *nw* consecutive I-frames, the working window value is increased until it reaches the value specified by MAXOUT for subarea connections, or the value specified in the VTAM switched major node for peripheral connections.

For NCP V7R1 and V7R2, the value in this field is defined by the *nw* suboperand of the DYNWIND keyword on the LINE statement for a physical frame-relay line. The value applies to all logical lines and stations associated with that physical line.

For NCP V7R3 or later releases, the value in this field is defined by the *nw* suboperand of the DYNWIND keyword on the PU statement for a logical subarea frame-relay station. For a peripheral station, the value is defined in the VTAM switched major node, or if not defined in VTAM, on the physical LINE statement.

DYNWIND(dw) (starting with NCP V7R1)

Value by which the sending NCP divides, or percentage by which the sending NCP reduces, the IEEE 802.2 LLC working window value when frame loss occurs. 1 is a special value which indicates that the working window value should be set to its minimum when frame loss is detected.

For NCP V7R1 and V7R2, the value in this field is defined by the *dw* suboperand of the DYNWIND keyword on the LINE statement for a physical frame-relay line. The value applies to all logical lines and stations associated with that physical line.

For NCP V7R3 or later releases, the value in this field is defined by the *dw* suboperand of the DYNWIND keyword on the PU statement for a logical subarea frame-relay station. For a peripheral station, the value is defined in the VTAM switched major node, or if not defined in VTAM, on the physical LINE statement.

DYNWIND(dwc) (starting with NCP V7R1)

Value by which the sending NCP divides, or percentage by which the sending NCP reduces, the IEEE 802.2 LLC working window value when backward explicit congestion notification (BECN) occurs. 1 is a special value which indicates that the working window value should be set to its minimum when BECN is indicated.

For NCP V7R1 and V7R2, the value in this field is defined by the *dwc* suboperand of the DYNWIND keyword on the LINE statement for a physical frame-relay line. The value applies to all logical lines and stations associated with that physical line.

For NCP V7R3 or later releases, the value in this field is defined by the *dwc* suboperand of the DYNWIND keyword on the PU statement for a logical subarea frame-relay station. For a peripheral station, the value is defined in the VTAM switched major node, or if not defined in VTAM, on the physical LINE statement.

DYNWIND(dwd) (starting with NCP V7R5; not applicable to 3746 Model 900 frame-relay logical lines)

Upper bound for the I-frame delay, in seconds. The value in this field is defined by the *dwdmax* suboperand of the DYNWIND keyword on the LINE or PU statement.

STATION (starting with NCP V7R6)

Whether the station can be used for hot standby (STANDBY) or cannot (NORMAL), as defined by the TGCONF keyword on the PU definition statement.

T1 Timer

Reply timer (T1) value for stations connected to a frame-relay network. Defined by the LOCALTO keyword on the LINE statement or the *localt1* suboperand of the T1TIMER keyword on the LINE statement.

T2 Timer(1)

Acknowledgement timer (T2) value as defined by the *localt2* suboperand of the T2TIMER keyword on the LINE statement.

N3GEN

Generated maximum number of I-frames received before sending an acknowledgement. Defined by the *n3* suboperand of the T2TIMER keyword on the LINE statement.

#PIUs/block

Generated maximum number of PIUs for each frame as defined by the *pjus* suboperand of the BLOCK keyword on the PU statement.

DYNWIND(*twc*) (starting with NCP V7R5; not applicable to 3746 Model 900 frame-relay logical lines)

YES or NO to specify whether NCP should ignore subsequent BECNs for 100 ms after an initial BECN is received. Defined by the *twcuse* suboperand of the DYNWIND keyword on the LINE or PU statement.

MODE (starting with NCP V7R6)

Whether the station is in standby mode (STANDBY) or normal mode (NORMAL).

NCP Physical Line

Line Addr

Physical line address, as defined by the ADDRESS keyword on the LINE statement.

type

Line adapter type: TSS (low speed), HPTSS (high speed), or CLP (communication line processor).

PORTADD

Port number for this physical frame-relay line as defined by the PORTADD keyword on the LINE statement. This number is used to select a physical line during connect-out processing for logical peripheral lines. A dash (-) is displayed in this field if PORTADD is not coded for the line.

status

Physical line status: ACTIVE or INACTIVE.

MAXFRAME

Maximum frame size, in bytes, for this line. This is determined by the transmission group segment size. This might not equal the value of the MAXFRAME keyword on the LINE statement. For more information about transmission group segment size, see *NCP, SSP, and EP Resource Definition Guide*.

CUR GEN

This section displays current and generated values for certain parameters. The CUR fields are working values that are either set or limited by the corresponding GEN fields. The GEN fields are either the values from the NCP generation or the values resulting from subsequent NCP processing that overwrote the values from the NCP generation.

MAXDATA CUR

Current maximum inbound frame size for the destination station. This field is a working value that is either set or limited by the MAXDATA GEN field.

MAXDATA GEN

Generated maximum inbound frame size for the destination station. GEN is either the value from the NCP generation (MAXDATA keyword on the PU statement) or the value resulting from subsequent NCP processing that overwrote the generated value.

MAXOUT CUR (not available for 3746 Model 900)

For both peripheral and subarea FRTE stations, MAXOUT CUR specifies the maximum number of information frames (I-frames) that can be sent to an adjacent link station without having to be acknowledged. MAXOUT CUR is used to set the upper bound for the working window (WW). This field is

limited by the value of MAXOUT GEN but might differ from MAXOUT GEN based on negotiations with the adjacent link station.

For more details on this subject, please see the description of the MAXOUT keyword on the PU statement in *NCP, SSP, and EP Resource Definition Reference*.

MAXOUT GEN

Generated MAXOUT value, used to negotiate MAXOUT CUR.

Peripheral FRTE stations are defined as switched resources. Therefore, the MAXOUT GEN value for these stations comes from the PU definition statement in the VTAM switched major node (SMN) definitions.

Subarea FRTE stations are defined as nonswitched resources. Therefore, the MAXOUT GEN value for these stations comes from the NCP PU definition statement that defines the subarea station.

BLOCK CUR

Current maximum frame size.

BLOCK GEN

Generated maximum frame size in bytes. GEN is either the value from the NCP generation (*bytes* suboperand of the BLOCK keyword on the PU statement) or the value resulting from subsequent NCP processing that overwrote the generated value.

PIUCHECK CUR (starting with NCP V7R7; subarea stations only)

Current YES or NO value indicating whether a checksum validation is performed on PIUs sent from and received by this station. This field is a working value that is either set or limited by the PIUCHECK GEN field for this station and the adjacent link station.

PIUCHECK GEN (starting with NCP V7R7; subarea stations only)

Generated YES or NO value indicating whether a checksum validation is performed on PIUs sent from and received by this station. This field, unless tuned, is the value from the NCP generation (PIUCHECK keyword on the PU statement).

MimWW CUR (starting with NCP V7R8; not applicable to 3746 Model 900 frame-relay logical lines)

Current lower bound for the IEEE 802.2 LLC working window when the window is reduced for frame loss or BECN.

MimWW GEN (starting with NCP V7R8; not applicable to 3746 Model 900 frame-relay logical lines)

Generated lower bound for the IEEE 802.2 LLC working window when the window is reduced for frame loss or BECN. Defined by the *mww* suboperand of the DYNWIND keyword on the LINE or PU statement.

DESTINATION STATION

IDBLK-IDNUM (peripheral stations)

Device type and identification number as defined by VTAM switched major node.

CPNAME (type 2.1 PUs)

Control point name of the PU.

PU Status

Status of the logical PU associated with this logical line. This can be any of the following:

INACTIVE	Reset
XID PEND	XID pending with data
XID NODT	XID pending without data
CONT PND	Contact pending
PENDING	Contact and discontact pending
ACTIVE	Active (normal data)
LOAD/DMP	Load/Dump/RPO active
SIM PEND	Set Initialization Mode pending
DISC PND	Discontact pending
LL2 ACT	Link-level 2 active
LL2 PND	Link-level 2 pending

DSAP

Destination service access point (DSAP), part of the address field of LLC frames.

TG

Transmission group number.

SUBAREA

Address of the NCP at the other end of the PVC.

NETID

Network identifier of the NCP at the other end of the PVC.

FRAME RELAY BAN CONNECTION

Destination Address

(3745, starting with NCP V7R1, peripheral lines)
(3746, starting with NCP V7R3, peripheral lines)
(3746, starting with NCP V7R5, peripheral and subarea lines)
 MAC address of the destination station for a frame-relay BAN connection.

SERVICE PRIORITY (starting with NCP V7R7; 3746 Model 900 only)

A relative service priority, at a station level, for the displayed 3746 Model 900 attached frame-relay terminating equipment. Defined by the FRSPRI keyword on the PU statement.

PF Keys

F1=HELP

Displays online help for this panel.

F3=RETURN

Returns to the previous NTuneMON panel.

F5=MODIFY

Available when the operator has tuning authority and NTuneNCP is included. For more information, refer to Chapter 5, Using the NTuneNCP Tuning Feature.

Updates the NCP tuning parameter with the modified value. When the modification is not valid, the field turns reverse-video pink and you are prompted to correct the value and resubmit the request.

F6=ROLL

Returns to the NetView command line without exiting NTuneMON. To return to NTuneMON from the NetView program, press F6=ROLL or enter **ATUNEMON** on the NetView command line.

F8=FORWARD

Scrolls forward to ATUFT2 Frame Relay Terminating Equipment Details Page 2 as shown on page 4-143.

F10=HEX

Displays the ATUDP Hexadecimal Storage Display panel, as shown on page 4-68, to show the logical link control block (LLB) for a 3745 line or the station control block extension (SCE) for a 3746 Model 900 line.

F12=REFRESH

Refreshes the information on this panel.

ENTER=TG DETAILS

Displays the ATUML Multi-Link Transmission Group panel, as shown on page 4-184, for more information about the transmission group and the origin and destination NCPs.

PA1=EXIT

Exits NTuneMON.

PA2=LOG

Saves the information on this panel to the NetView log.

ATUFT2 Frame Relay Terminating Equipment Details Page 2 Panel

Basic fast-path commands: None.

Tuning fields: COMRATE

```

ATUFT2 A04D1          Frame Relay Terminating      NTuneMON V2R6  12:47
                       Equipment Details Page 2
LLC Status: Link Opened

DLCI      = 17(11)          BECN SNT      = 0
LINE NAME = J00041FF       BECN RCVD     = 0
LINE STATUS= ACTIVE        FECS RCVD     = 0
PU NAME   = J0004200       DE BITS SNT   = 0
COMRATE   = ( FULL , 1 )   DE BITS RCVD  = 49152
                                           FRMS DSCRD   = 0

Frame Statistics:
      Transmit      Receive
DLCI Status      = ACTIVE  ACTIVE
Estimated Bytes  = -      -
Maximum Size Frame = 264   1034
Minimum Size Frame = 15    15
Frames Count     = 0.0/Sec 0.0/Sec
WW / OUTS. FRAME COUNT = 3/0      MAXOUT CUR = 3
N3 / I-Frame Rcv count =          1/0
                                           Minimum working window = 3

=>
F1=HELP F3=RETURN  F4=RESET MIN/MAX F5=MODIFY F6=ROLL F7=BACK F10=HEX
ENTER-TG DETAILS F12=REFRESH/RATES PA1=EXIT PA2=LOG
    
```

Figure 4-40. ATUFT2 Frame Relay Terminating Equipment Details Page 2 Panel

Description

The ATUFT2 Frame Relay Terminating Equipment Details Page 2 panel, which is available for NCP V6R2 or later releases, displays information on the logical line associated with a particular DLCI.

To display this panel: On the ATUFT1 Frame Relay Terminating Equipment Details Page 1 panel, as shown on page 4-135, press F8.

Fields

NCP name (second field on panel)

Name of the NCP that is currently displayed. You can enter a different NCP name in this field to display information on another NCP.

LLC Status (not available for 3746 Model 900)

Status of the Type 2 logical line as defined by IEEE 802.2 LLC.

Logical Link Closed

The link is no longer active. Although the information displayed represents an inactive station, the information may be used to resolve problems with unsuccessful dial-in attempts.

XID Response Pending NCP is waiting for the XID response.

FRMR Sent

A frame reject was sent.

FRMR Received

A frame reject was received.

INOP in Progress	The link is attempting to recover from an error.
Link Opening	The link is being opened.
Link Opened	The link is open for communications.
Link Clearing	The link is being cleared.
Link Disconnecting	The link is being disconnected.
Link Disconnected	The link is disconnected.
LL2 ACT	Link-level 2 is active.
LL2 PND	Link-level 2 is pending.

DLCI

DLCI associated with this logical line, shown in decimal and hexadecimal formats. Defined by the DLCI or ADDR keyword on the PU statement.

LINE NAME

Name of the logical line.

LINE STATUS

Status of this logical line. This can be any of the following:

PEND ACTLINK	An activate link command (ACTLINK) is in progress.
ACTIVE	An ACTLINK has been processed, and the line is active.
PEND DACTLNK	A deactivate link command (DACTLINK) is in progress.
INACTIVE	A DACTLINK has been processed, and the line is inactive.
FORCE DEACT	The line has been forced into deactivation. (A force deactivate command was issued from VTAM.)
PEND ANS	Line quiescence is pending due to ANS.

PU NAME

Name of the PU associated with this DLCI. This name is the label on the PU statement.

COMRATE (FULL|NONE,priority)

Whether certain frames sent by this TESP can be discarded by the frame-relay network to expedite the processing of other frames when the network is congested. It also specifies the relative transmit priority for a TESP.

Defined by the COMRATE keyword on the LINE and PU statements.

COMRATE FULL|NONE

Status of the discard-eligible (DE) indicator for this TESP as defined by the FULL|NONE suboperand of the COMRATE keyword on the LINE statement. FULL indicates that **no** frames sent by this TESP are discard-eligible. NONE indicates that **all** frames sent by this TESP are discard-eligible except for the following types:

- S frames (RR, RNR, and REJ), including RRs piggybacked on I-frames
- Network priority frames (virtual route pacing and TG sweep)
- XIDs

Discard-eligible frames are discarded before non-discard-eligible frames to relieve severe network congestion.

COMRATE priority (NCP V7R2 or later releases)

Relative transmit priority for a TESP as defined by the *priority* suboperand of the COMRATE keyword on the PU statement. *Priority* is multiplied by the value of the DATBLK keyword on the LINE statement to determine the guaranteed minimum number of bytes that a TESP can transmit before a different TESP must be given a transmission opportunity.

BECNS SENT (starting with NCP V7R6; not available for 3746 Model 900)

Number of frames transmitted by this TESP with the BECN bit on.

Note: Set the NTUNECOL keyword on the BUILD definition statement to YES to allow this data to be collected and displayed.

BECNS RECEIVED (starting with NCP V7R3; not available for 3746 Model 900)

Number of frames received by this TESP with the BECN bit on.

Note: Set the NTUNECOL keyword on the BUILD definition statement to YES to allow this data to be collected and displayed.

FECNS RECEIVED (starting with NCP V7R3; not available for 3746 Model 900)

Number of frames received by this TESP with the FECN bit on.

Note: Set the NTUNECOL keyword on the BUILD definition statement to YES to allow this data to be collected and displayed.

DE BITS SENT (starting with NCP V7R3; not available for 3746 Model 900)

Number of frames transmitted by this TESP with the DE bit on.

Note: Set the NTUNECOL keyword on the BUILD definition statement to YES to allow this data to be collected and displayed.

DE BITS RECEIVED (starting with NCP V7R6; not available for 3746 model 900)

Number of frames received by this TESP with the DE bit on.

Note: Set the NTUNECOL keyword on the BUILD definition statement to YES to allow this data to be collected and displayed.

FRAMES DISCARDED (starting with NCP V7R3; not available for 3746 Model 900)

Number of frames discarded by this TESP.

Note: Set the NTUNECOL keyword on the BUILD definition statement to YES to allow this data to be collected and displayed.

Frame Statistics

The following fields provide information on traffic transmitted and received over this line:

DLCI Status (not available for 3746 Model 900)

Status of the DLCI as indicated by NCP (Transmit) and by the frame-relay network (Receive). ACTIVE under Transmit indicates that NCP can receive frames from the network over the DLCI. ACTIVE under Receive indicates that the network can receive frames from NCP over the DLCI.

Estimated Bytes (starting with NCP V7R3; not available for 3746 Model 900)

Estimated bytes per second (*n/SEC*) transmitted and received over this line. The number of bytes is estimated by taking the average of the maximum size frame sent and the minimum size frame sent. To get a more current estimate, press F4 to reset the Maximum Size Frame Sent and Minimum Size Frame Sent fields. NTuneMON resets the fields and automatically refreshes the panel. If new traffic rates are available, they are displayed. Otherwise, a dash (–) displays until new traffic rates are available and you press F12 to refresh the traffic rates.

Note: Set the NTUNECOL keyword on the BUILD definition statement to YES to allow this data to be collected and displayed.

Maximum Size Frame (starting with NCP V7R3; not available for 3746 Model 900)

Maximum size frame (in bytes) transmitted and received over this line since the last time this field was reset by NTuneMON. If you reset this field by pressing F4, NTuneMON automatically refreshes the panel and displays the new traffic rate if it is available. Otherwise, NTuneMON displays a dash (–) until the new traffic rate is available and you press F12 or reenter the panel to display the new rate.

Note: Set the NTUNECOL keyword on the BUILD definition statement to YES to allow this data to be collected and displayed.

Minimum Size Frame (starting with NCP V7R3; not available for 3746 Model 900)

Minimum size frame (in bytes) transmitted and received over this line since the last time this field was reset by NTuneMON. If you reset this field by pressing F4, NTuneMON automatically refreshes the panel and displays the new traffic rate if it is available. Otherwise, NTuneMON displays a dash (–) until the new traffic rate is available and you press F12 or reenter the panel to display the new rate.

Note: Set the NTUNECOL keyword on the BUILD definition statement to YES to allow this data to be collected and displayed.

Frames Count (not available for 3746 Model 900)

Traffic rates for transmitted and received frames. These values are based on the elapsed time since the last refresh of this panel. Values are shown in reverse-video yellow if they have changed or if a rate is greater than one frame per second (*n/S*). Unchanged values are shown in blue.

Note: Set the NTUNECOL keyword on the BUILD definition statement to YES to allow this data to be collected and displayed.

WW/Outs. Frame Count (not available for 3746 Model 900)

WW (working window) is the maximum number of frames that can be transmitted without receiving an acknowledgement. WW is initialized to MAXOUT Cur and then may be modified depending on traffic flow.

Outs. Frame Count (outstanding frame count) is the number of frames currently waiting for an acknowledgement. When this number reaches WW, no frames can be transmitted until acknowledgement is received.

N3/I-Frame Rcv Count (not available for 3746 Model 900)

N3 is the current value for the maximum number of I-frames to receive before sending an acknowledgement. For subarea stations, N3 is initialized from N3GEN.

I-frame Rcv Count (I-frame received counter) is the current number of I-frames received without sending an acknowledgement. I-frame Rcv Ct is initialized to N3 and decreases by one each time an I-frame is received, which means the counter counts down instead of up. If a rate is less than one frame per second, the current sequence number is shown in turquoise.

MAXOUT CUR (starting with NCP V7R6; not available for 3746 Model 900)

For both peripheral and subarea FRTE stations, MAXOUT CUR specifies the maximum number of information frames (I-frames) that can be sent to an adjacent link station without having to be acknowledged. MAXOUT CUR is used to set the upper bound for the working window (WW). This field is limited by the value of MAXOUT GEN but might differ from MAXOUT GEN based on negotiations with the adjacent link station.

For more details on this subject, please see the description of the MAXOUT keyword on the PU statement in *NCP, SSP, and EP Resource Definition Reference*.

Minimum working window (starting with NCP V7R8; not applicable to 3746 Model 900 frame-relay physical lines)

Lower bound for the IEEE 802.2 LLC working window when the window is reduced for frame loss or BECN. Defined by the *mww* suboperand of the DYNWIND keyword on the LINE or PU statement.

PF Keys

F1=HELP

Displays online help for this panel.

F3=RETURN

Returns to the previous NTuneMON panel.

F4=RESET MIN/MAX (starting with NCP V7R3)

Available when the operator has tuning authority and NTuneNCP is included. For more information, refer to Chapter 5, Using the NTuneNCP Tuning Feature.

Resets the values of both the transmitted and received Maximum Size Frame Sent and Minimum Size Frame Sent fields. After resetting the fields, NTuneMON automatically refreshes the panel. If new traffic rates are available, they are displayed. Otherwise, NTuneMON displays a dash (–) until new traffic rates are available and you press F12 or reenter the panel to display the new rates.

F5=MODIFY

Available when the operator has tuning authority and NTuneNCP is included. For more information, refer to Chapter 5, Using the NTuneNCP Tuning Feature.

Updates the NCP tuning parameter with the modified value. When the modification is not valid, the field turns reverse-video pink and you are prompted to correct the value and resubmit the request.

F6=ROLL

Returns to the NetView command line without exiting NTuneMON. To return to NTuneMON from the NetView program, press F6=ROLL or enter **ATUNEMON** on the NetView command line.

F7=BACK

Scrolls back to ATUFT1 Frame Relay Terminating Equipment Details Page 1 as shown on page 4-135.

F10=HEX

Displays the ATUDP Hexadecimal Storage Display panel, as shown on page 4-68, to show the logical link control block (LLB) for a 3745 line or the station control block extension (SCE) for a 3746 Model 900 line.

ENTER=TG DETAILS

Displays the ATUML Multi-Link Transmission Group panel, as shown on page 4-184, for more information about the transmission group and the origin and destination NCPs.

F12=REFRESH/RATES

Refreshes the information on this panel and displays traffic rates.

PA1=EXIT

Exits NTuneMON.

PA2=LOG

Saves the information on this panel to the NetView log.

ATUGP Network CB Pools/Tables Panel

Basic fast-path commands: None

Tuning fields: GWPACING

```

ATUGP A27GENC      Network CB Pools / Tables      NTuneMON V2R6  14:24
                  NETWORK = NETA                SUBAREA = 27
-----
NETWORK  MAX  CUR  ALERT  MAX  CUR  FREE  FREE  TOTAL  DYNA  PERM
CB POOLS  USE  USE  THRS  USE  USE  UNRSVD  RSV  D  D  ASSIGN
-----
GWNAU    0%   0%  80%    0    0    0      0    0      0      0
TGB       50%  50%  80%    1    1    1      0    2      N/A    0
TRT       0%   0%  80%    1    1   253    0   254    N/A    0
-----
Max Network Limit =    0
Use Network Count =    0
Subarea Limit     =  511
ER Limit          =   16

GWPACING         = ( 0 , ADAP , ALLOW )
=> _
F1=HELP  F2=CBPOOLS  F3=RETURN  F4=BUFPPOOL  F5=MODI  F6=ROLL  F10=HEX
F12=REFRESH  PA1=EXIT  PA2=LOG
    
```

Figure 4-41. ATUGP Network CB Pools/Tables Panel

Description

The ATUGP Network CB Pools/Tables panel, which is available beginning with NCP V7R1, monitors network details and enables tuning of unpaced-session parameters. For information on NCP control block pools, see “ATUCB Control Block Pools/Tables Panel” on page 4-17.

To display this panel: On the ATUNG HSCBs and GWNAUs panel, as shown on page 4-195, place the cursor under a network name and press F2.

Fields

NCP name (second field on panel)

Name of the NCP that is currently displayed.

NETWORK

Network name.

SUBAREA

Network subarea address.

NETWORK CB POOLS

The NETWORK CB POOLS column of this panel lists the following control block pools.

GWNAU

Gateway network addressable unit control blocks (NLB/NIB pairs), as defined by the NUMADDR keyword on the GWNAU statement.

GWNAUs defined by the ELEMENT, NAME, and NETID keywords on the GWNAU statement are considered permanently assigned.

TGB

All transmission group control blocks, including those defined by the TGBXTRA keyword on the BUILD and NETWORK statements.

TGBs cannot be dynamically created with the NCP dynamic control block function.

TRT

All transit routing table entries, including those defined by the PATHEXT keyword on the BUILD and NETWORK statements.

TRTs cannot be dynamically created with the NCP dynamic control block function.

Use Information

The following use information is shown for each of the control block pools described previously.

MAX USE (%)

Highest percentage of control blocks in use since NCP was loaded. When the maximum percentage of CBs in use reaches the ALERT THRS value, the percent is highlighted in reverse-video red. A generic alert is issued (if specified).

CUR USE (%)

Control blocks in use, shown as a percentage of the total number of non-dynamic control blocks currently in the pool. If the value in this field exceeds the alert threshold, it is highlighted in reverse-video red. If this happens, you might want to increase the number of generated resources and regenerate the NCP.

ALERT THRS

Alert threshold for control block use for each control block pool.

If the current or maximum control block percentages reach this value, the percentage fields are highlighted in reverse-video red. NTuneMON keeps track of the maximum percent of control blocks in use. When the current maximum percent of control blocks in use exceeds the maximum percent in use NTuneMON has detected so far, it issues a generic alert (if specified). The current maximum percent then becomes the value that determines when the next generic alert is sent.

You can enter values in this column to change the alert threshold for each pool. You can make the alert threshold greater than 100 if you want no alerts to be issued.

MAX USE

Highest number of control blocks in use since NCP was loaded.

CUR USE

Number of control blocks currently in use.

FREE UNRSVD

Number of free control blocks in the unreserved control block pool. Control blocks in the unreserved control block pool can be used by any appropriate resource.

FREE RSVD

Number of free control blocks in the reserved control block pool. The number of reserved control blocks depends on the particular pool. The reserved pool is not used for any other control blocks.

For NLBs, the count is the number of NLBs currently free that have pre-ENA addresses.

The MAXSUBA keyword coded on the BUILD statement determines the range of pre-ENA addresses.

TOTAL

Total number of control blocks defined for the pool. This total is the sum of CUR USE, FREE UNRSVD, and FREE RSVD. This total does not include control blocks permanently assigned to a particular resource.

DYNA

Number of control blocks currently in use that were dynamically created in buffers for this network by using the dynamic control block function. If this field contains a nonzero value, it is highlighted in reverse-video pink. If there are dynamic control blocks, you might want to increase the number of generated resources and regenerate the NCP.

PERM ASSIGN (starting with NCP V7R1)

Number of control blocks permanently assigned to a particular resource. These control blocks are not included in any of the other counts or calculations. See the individual control block pool descriptions for details. There are no permanently assigned resources unless otherwise specified.

Network-Wide Parameters

This section of the panel is available starting with NCP V7R1. It applies to networks, other than the native network, that the gateway NCP joins.

Max Network Limit

Maximum number of half-session control blocks for this network. Defined by the NETLIM keyword on the BUILD or NETWORK statement.

Use Network Count

Number of used half-session control blocks for this network.

Subarea Limit

The largest subarea address supported by this node in the nonnative network. Defined by the SALIMIT keyword on the BUILD or NETWORK statement.

ER Limit

Whether NCP is to support 8 or 16 explicit routes for this nonnative network. Defined by the ERLIMIT keyword on the BUILD or NETWORK statement.

GWPACING

Actions to take during a cross-network session if the BIND request or response indicates that session pacing will not control the flow of data for this session. Defined by the GWPACING keyword on the BUILD or NETWORK statement.

First GWPACING Value

Pacing window size that can override the session pacing parameters in a negotiable BIND for SNA LU-LU cross-network sessions. Defined by the *window* suboperand of the GWPACING keyword.

ATUGP Network CB Pools/Tables Panel

Second GWPACING Value

Action to be taken on BIND for SNA LU-LU cross-network sessions for which adaptive session pacing can be used.

ADAP

Allows the BIND to pass through unchanged.

FIXED

Turns off the adaptive session pacing support bit in the BIND.

Third GWPACING Value

Action to be taken on nonnegotiable BINDs and negotiable BIND responses for the activation of SNA LU-LU cross-network sessions for which no session pacing will be used.

ALLOW

Allows the session activation attempt to proceed.

FAIL

Prevents the session activation from proceeding.

PF Keys

F1=HELP

Displays online help for this panel.

F2=CBPOOLS

Displays the ATUCB Control Block Pools/Tables panel, as shown on page 4-17, to show information on the use of NCP control block pools.

F3=RETURN

Returns to the previous NTuneMON panel.

F4=BUFPOOL

Displays the ATUBP NCP Buffer Pool panel, as shown on page 4-4, to show information on the NCP buffer pool and its subpools.

F6=ROLL

Returns to the NetView command line without exiting NTuneMON. To return to NTuneMON from the NetView program, press F6=ROLL or enter **ATUNEMON** on the NetView command line.

F10=HEX

Displays the ATUDP Hexadecimal Storage Display panel, as shown on page 4-68, to show the queue anchor block (QAB).

F12=REFRESH

Refreshes the information on this panel.

PA1=EXIT

Exits NTuneMON.

PA2=LOG

Saves the information on this panel to the NetView log.

ATUHP HPR & Other Global Flow Control Params Panel

Basic fast-path commands: HP, HPR

Tuning fields: HPRSMPS, HPRSATT, HPRSMLC, Subarea Stage, Rex Stage

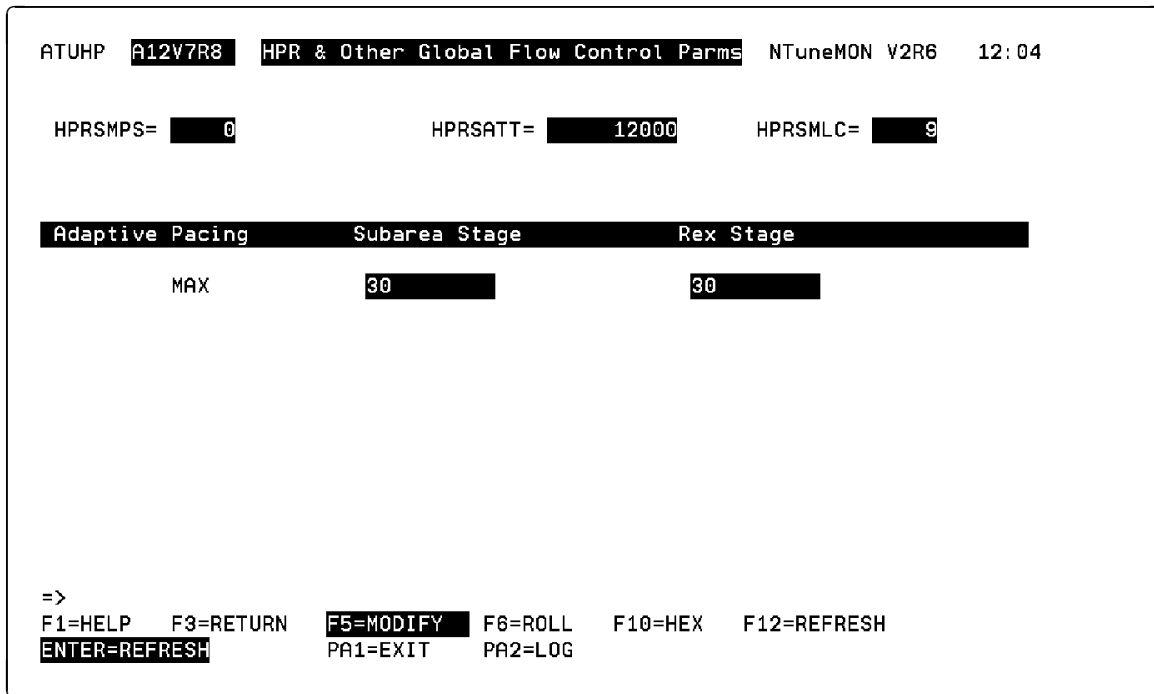

Figure 4-42. ATUHP HPR & Other Global Flow Control Params Panel

Description

The ATUHP HPR & Other Global Flow Control Params panel is available for NCP V7R3 or later releases and only for HPR and APPN resources. It provides information about HPR and other global flow control parameters.

To display this panel: On the ATUBP NCP Buffer Pool panel, as shown on page 4-4, press F7.

Fields

NCP name (second field on panel)

Name of the NCP that is currently displayed.

HPRSMPS

Largest packet that can be sent across the composite automatic network routing (ANR) node's subarea network without being segmented on any of the subarea links along the path. Defined by the HPRMPS keyword on the BUILD statement.

HPRSATT

Accumulated transmission time, in microseconds, that it takes to route 1200 bits across a typical path in the composite ANR node's subarea network. Defined by the HPRATT keyword on the BUILD statement.

HPRMLC

Minimum link capacity, in kilobits per second, for the slowest subarea transmission group in the composite ANR node's subarea network that can carry APPN HPR data. Defined by the HPRMLC keyword on the BUILD statement.

Adaptive Pacing MAX

These fields, available beginning with NCP V7R8, show the maximum window sizes that NCP sends in an adaptive pacing response message.

Subarea Stage

Maximum window size that NCP sets in an adaptive pacing response message (IPM) sent on the subarea stage. Defined by the *max_window_subarea* suboperand of the ADPLIMIT keyword on the BUILD statement.

Rex Stage

Maximum window size that NCP sets in an adaptive pacing response message (IPM) sent on the rex stage. Defined by the *max_window_rex* suboperand of the ADPLIMIT keyword on the BUILD statement.

PF Keys

F1=HELP

Displays online help for this panel.

F3=RETURN

Returns to the previous NTuneMON panel.

F5=MODIFY

Available when the operator has tuning authority and NTuneNCP is included. For more information, refer to Chapter 5, Using the NTuneNCP Tuning Feature.

Updates the NCP tuning parameter with the modified value. If the modification is not valid, the field turns reverse-video pink, and you are prompted to correct the value and resubmit it.

F6=ROLL

Returns to the NetView command line without exiting NTuneMON. To return to NTuneMON from the NetView program, press F6=ROLL or enter **ATUNEMON** on the NetView command line.

F10=HEX

Displays the ATUDP Hexadecimal Storage Display panel, as shown on page 4-68, to show the HPR control block.

F12=REFRESH

Refreshes the information on this panel.

ENTER=REFRESH

Refreshes the information on this panel.

PA1=EXIT

Exits NTuneMON.

PA2=LOG

Saves the information on this panel to the NetView log.

ATUIA ARP Table Entry Panel

Basic fast-path commands: None

Tuning fields: None

```

ATUIA  A71NT06      ARP Table Entry      NTuneMON V2R1      15:28

IP Address          10.4.28.99      Local IP Address
                               10.71.28.99
H/W Address         08A1
Frame Format Type Established NO      Entry Completion Indicator YES
Entry Type          PERMANENT      Previous Address    NOT AVAILABLE
Frame Format Type    Frame Relay
Routing Information Present NO

=>
F1=HELP F2=IP DETAILS F3=RETURN F4=IPLIST F6=ROLL F10=HEX F12=REFRESH
ENTER = SEE NEXT ARP TABLE ENTRY PA1=EXIT PA2=LOG

```

Figure 4-43. ATUIA ARP Table Entry Panel

Description

The ATUIA ARP Table Entry panel, which is available for NCP V6R1 or later releases, displays an ARP table entry (ATE) based on an IP address entered for a specific interface. ARP is used to discover the hardware address of an IP host. The ARP entry contains the hardware address and, if applicable, source route information about an IP host.

To display this panel:

- On the ATUIL IP Interface Information panel, as shown on page 4-169, place the cursor under an IP address for an Ethernet, Token-Ring, frame-relay, or channel interface and press F11.
- From the ATUID IP Interface Information Detail panel, as shown on page 4-164, press F11.

Fields

NCP name (second field on panel)

Name of the NCP that is currently displayed.

IP Address

Four-byte IP address of the destination resource, as defined by:

- The IPADDR keyword of the IPLOCAL statement for Token Ring or Ethernet
- The P2PDEST keyword of the PU or IPLOCAL statement for frame relay, channel, and internal 3746 Model 900 point-to-point IP connections

ATUIA ARP Table Entry Panel

Local IP Address

Four-byte IP address of the local (source) resource, as defined by:

- The LADDR keyword of the IPLOCAL statement for Token Ring
- The LADDR keyword of the PU or IPLOCAL statement for frame relay, channel, and internal 3746 Model 900 point-to-point IP connections

H/W Address

Hardware address of the destination resource as known to this NCP.

Frame Format Type Established

YES or NO to indicate whether a format type has been established.

Entry Completion Indicator

YES or NO to indicate whether ARP processing is complete. If it is not complete, only the IP address is displayed.

Entry Type

Entry type: PERMAMENT or NON PERM (non-permanent) as defined by the DISP keyword on the IPRROUTE statement.

Previous Address

If you have displayed several ARP entries, this is the IP address of the previous ARP entry displayed.

Frame Format Type

Frame format type: IEEE 802.3, IEEE 802.5, Ethernet V2, frame relay, or channel.

Routing Information Present (Token Ring)

YES or NO to indicate whether information about the route to a particular destination is included.

PF Keys

F1=HELP

Displays online help for this panel.

F2=IP DETAILS

Displays the ATUID IP Interface Information Detail panel, as shown on page 4-164, to show details about a specific IP interface.

F3=RETURN

Returns to the previous NTuneMON panel.

F4=IPLIST

Displays the ATUIL IP Interface Information panel, as shown on page 4-169, to show information about an IP interface.

F6=ROLL

Returns to the NetView command line without exiting NTuneMON. To return to NTuneMON from the NetView program, press F6=ROLL or enter **ATUNEMON** on the NetView command line.

F10=HEX

Displays the ATUDP Hexadecimal Storage Display panel, as shown on page 4-68, to show the ARP table entry (ATE) control block for this IP address.

F12=REFRESH

Refreshes the information on this panel.

ENTER=SEE NEXT ARP TABLE ENTRY

Displays the next ARP table entry, if any.

PA1=EXIT

Exits NTuneMON.

PA2=LOG

Saves the information on this panel to the NetView log.

before NCP V6R2, the upper portion of the panel shows combined GWNAU use counts (Figure 4-45).

Note: This panel is not displayed for NCP V7R1 or later releases. See “ATUIB Non-Dynamic GWNAUs in Use Counts Panel” on page 4-161.

The lower portion of the panel lists all GWNAUs currently in use by name.

GWNAU names are color-coded as follows:

Yellow	System services control point (SSCP) name
Turquoise	Primary logical unit (PLU) name
Green	Logical unit (LU) name

The number of unreserved GWNAUs (NIB/NLB pairs) in each network is defined by the NUMADDR keyword on the GWNAU statement. The name of each reserved GWNAU is defined by NAME on the GWNAU statement. Two GWNAUs are used for each cross-network SNI session and can be shared among different sessions with the same PLU.

NCP releases before V6R2: This analysis can take a long time to run and can use a large amount of NetView storage and processing time.

The GWNAU use counts represent the number of HSCBs (NIX/NLX pairs) associated with each GWNAU, up to a maximum of 255. Each HSCB represents one cross-network SNI session. SSCP's do not use HSCBs.

Figure 4-55 on page 4-192 shows the use of GWNAUs and HSCBs in a gateway NCP.

Fields

NCP name (second field on panel)

Name of the NCP that is currently displayed. You can enter a different NCP name in this field to display information about another NCP.

NETID

Name of the network currently displayed.

UNRESERVED GWNAUs IN USE / TOTAL (NCP V6R2 or V6R3)

Percentage and number of unreserved GWNAUs currently in use, and total number of unreserved GWNAUs, as defined by the NUMADDR keyword on the GWNAU statement.

RESERVED GWNAUs IN USE / TOTAL (NCP V6R2 or V6R3)

Percentage and number of reserved GWNAUs currently in use, and total number of reserved GWNAUs, as defined by the ELEMENT, NAME, and NETID keywords on the GWNAU statement.

ALL GWNAUs IN USE (NCP V6R1 or earlier releases)

Percentage and number of GWNAUs currently in use.

TOTAL (NCP V6R1 or earlier releases)

Total number of GWNAUs, as defined by the NUMADDR, ELEMENT, NAME, and NETID keywords on the GWNAU statement.

ATUIB GWNAUs in Use Counts Panel

MAX IN USE

Highest percentage and number of GWNAUs in use since this NCP was loaded. If the value of the percentage field exceeds 100 percent, the field is highlighted in reverse-video pink.

THRESHOLD

Alarm threshold for GWNAU use. You can enter a value in this field to change the alarm threshold. NTuneMON issues a generic alert (if specified) when the number of GWNAUs in use for a network reaches this percentage of the total number of GWNAUs defined for that network.

A shortage of GWNAUs can cause session activation to fail with an insufficient resource sense code. If the total number of GWNAUs in use nears the alarm threshold, increase the value of the NUMADDR keyword on the GWNAU statement.

The remainder of the panel lists the GWNAUs currently in use and the number of HSCBs associated with each GWNAU.

PF Keys

F1=HLP

Displays online help for this panel.

F3=RETURN

Returns to the previous NTuneMON panel.

F6=ROLL

Returns to the NetView command line without exiting NTuneMON. To return to NTuneMON from the NetView program, press F6=ROLL or enter **ATUNEMON** on the NetView command line.

F7=BACK

Scrolls the panel data backward one screen.

F8=FORWARD

Scrolls the panel data forward one screen.

F10=HEX

Displays the ATUDP Hexadecimal Storage Display panel, as shown on page 4-68, to show the network vector table (NVT).

F12=REFRESH

Refreshes the information on this panel.

Note: This analysis can take a long time.

PA1=EXIT

Exits NTuneMON.

PA2=LOG

Saves the information on this panel to the NetView log.

Fields

NCP name (second field on panel)

Name of the NCP that is currently displayed. You can enter a different NCP name in this field to display information about another NCP.

NETID

Name of the network currently displayed.

GWNAUs IN USE

Percentage and number of GWNAUs currently in use for this network. This includes both unreserved and reserved GWNAUs.

MAX IN USE

Highest percentage and number of GWNAUs in use since this NCP was loaded. If the value in this field is greater than 100 percent, it is highlighted in reverse-video pink.

PERM

Number of GWNAUs permanently assigned to a particular resource for this network as defined by the ELEMENT, NAME, and NETID keywords on the GWNAU statement. This number is not included in any other counts or calculations.

DYNA

Number of GWNAUs currently in use that were dynamically created in buffers using the NCP V7R1 dynamic CB function for this network. If this field contains a nonzero value, it is highlighted in reverse-video pink. If there are dynamic GWNAUs, you may want to increase the value for the NUMADDR keyword on the GWNAU statement, and regenerate the NCP. See *NCP and EP Reference* for more information.

FREE RSVD

Number of free GWNAUs in the reserved pool for this network. The reserved pool is used for GWNAUs defined by the NUMADDR keyword on the GWNAU statement that fall within the MAXSUBA keyword on the NETWORK statement (for gateway networks) or the BUILD statement (for local networks).

FREE UNRSVD

Number of free GWNAUs in the unreserved pool for this network.

TOTAL

Total number of GWNAUs. This total is the sum of GWNAUs IN USE + FREE RSVD + FREE UNRSVD. This total does not include GWNAUs that are permanently assigned to a particular resource.

THRESHOLD

Alarm threshold for GWNAU use. You can enter a value in this field to change the alarm threshold. NTuneMON issues a generic alert (if specified) when the number of GWNAUs in use for a network reaches this percentage of the total number of GWNAUs defined for that network.

A shortage of GWNAUs can cause session activation to fail with an insufficient resource sense code. If the total number of GWNAUs in use nears the alarm threshold, increase the value of the NUMADDR keyword on the GWNAU statement.

The remainder of the panel lists the GWNAUs currently in use and the number of HSCBs associated with each GWNAU.

PF Keys

F1=HELP

Displays online help for this panel.

F3=RETURN

Returns to the previous NTuneMON panel.

F6=ROLL

Returns to the NetView command line without exiting NTuneMON. To return to NTuneMON from the NetView program, press F6=ROLL or enter **ATUNEMON** on the NetView command line.

F7=BACK

Scrolls the panel data backward one screen.

F8=FWD

Scrolls the panel data forward one screen.

F10=HEX

Displays the ATUDP Hexadecimal Storage Display panel, as shown on page 4-68, to show the network vector table (NVT).

F12=REFRESH

Refreshes the information on this panel.

Note: This analysis can take a long time.

PA1=EXIT

Exits NTuneMON.

PA2=LOG

Saves the information on this panel to the NetView log.

ATUID IP Interface Information Detail Panel

Fast-path commands: ID, IPDETAIL either from the ATUIS IP Router Statistics Page 1 panel or, for NCP V7R1 or later releases, from the ATUIX IP Router Statistics Page 2 panel.

Tuning fields: ARP Address Format

```

ATUID  A71NT06  IP Interface Information Detail  NTuneMON V2R1  16:08
Interface Name      TR89
Interface Address   9.71.90.1      Enter the IP Address of the
                                     Interface that you would
                                     like to see.
Interface Type      TOKEN-RING      ARP Address Format:  NON-CANONICAL
Type of Connection  DIRECT CONNECT  Gateway Address     N/A
Status              ACTIVE          Subnetwork Mask     255.255.255.0
Broadcast Frames Support YES          Metric              12
Fragmentation Supported NO
MTU Size           150

=> _
F1=HELP F2=IP STATS F3=RETURN F4=IPLIST F5=MODIFY F6=ROLL F7=TR IP STATS
F9=ROUTENT F10=HEX F11=ARP F12=REFRESH PA1=EXIT PA2=LOG
ENTER=SEARCH FOR IP ADDRESS
    
```

Figure 4-47. ATUID IP Interface Information Detail Panel

Description

The ATUID IP Interface Information Detail panel, which is available for NCP V6R1 or later releases, displays information about a specific IP interface.

To display this panel:

- From the ATUCH Channel Adapter Details panel, as shown on page 4-32, press F2.
- From the ATUCL 3746-900 Station Details panel, as shown on page 4-39, press F2.
- From the ATUCI Channel IP Statistics panel, as shown on page 4-36, press Enter.
- From the second PF key selection of either the ATUTP1 Token-Ring TIC Details Page 1 panel, as shown on page 4-310, or the ATUTP2 Token-Ring TIC Details Page 2 panel, as shown on page 4-319, press F7.
- From the ATUTI Token-Ring IP Statistics panel, as shown on page 4-298, press Enter.

Note: If you have defined an internal 3746 Model 900 point-to-point IP connection, it is treated as a Token-Ring interface.

- On the ATUIL IP Interface Information panel, as shown on page 4-169, place the cursor under an interface address and press Enter.

- On the ATUIR IP Route Table Entries panel, as shown on page 4-172, place the cursor under an interface address and press Enter.
- From the ATUIA ARP Table Entry panel, as shown on page 4-155, press F2.
- On the ATUEP Ethernet Adapter List panel, as shown on page 4-81, place the cursor under an IP address and press F2.
- On the ATUFA Frame Relay Support List panel, as shown on page 4-88, place the cursor under an IPSP DLCI and press Enter.
- From the ATUFI Frame-Relay IP Link Statistics panel, as shown on page 4-102, press Enter.

See the descriptions of these panels for more information.

If you use the fast-path command from the ATUIS IP Router Statistics Page 1 panel or the ATUIX IP Router Statistics Page 2 panel, then the ATUID IP Interface Information Detail panel displays information about the owning host address.

Fields

NCP name (second field on panel)

Name of the NCP that is currently displayed.

Interface Name (starting with NCP V7R1)

Name of the interface, which must be unique within an NCP generation. The interface name is defined by the INTFACE keyword on:

- The LINE statement for Ethernet and Token-Ring LANs
- The LU statement for NCST
- The PU or IPLOCAL statement for frame relay, channel, and internal 3746 Model 900 point-to-point IP interfaces

Interface Address

Four-byte IP address of the interface as defined by the LADDR keyword on:

- The IPLOCAL statement for NCST, Ethernet, and Token Ring interfaces
- The PU or IPLOCAL statement for frame-relay, channel, and internal 3746 Model 900 point-to-point IP interfaces

To display this panel for another IP address, enter the address and press Enter.

Interface Type

Type of interface that this IP address is using: NCST, Ethernet, Token Ring, channel, or frame relay.

Note: If you have defined an internal 3746 Model 900 point-to-point IP connection, it is treated as a Token-Ring interface.

Type of Connection

Interface connection: POINT-TO-POINT or DIRECT.

Status

Status of the interface: ACTIVE or INACTIVE.

Broadcast Frames Support (not applicable to frame-relay, channel, or internal 3746 Model 900 point-to-point IP interfaces)

YES or NO to indicate whether simultaneous transmission of data to more than one host is supported.

Fragmentation Supported

YES or NO to indicate whether or not the process of dividing a datagram into smaller parts is supported. The purpose of fragmentation is to divide the datagram into parts that match the capabilities of the physical medium over which the datagram is to be transmitted.

MTU Size

Maximum transmission unit size: The largest possible unit of data that can be sent on a given physical medium in a single frame. MTU size is defined by the *mtu* suboperand of the INTFACE keyword on:

- The LINE statement for Ethernet and Token Ring
- The LINE or LU statement for NCST
- The PU statement for frame relay and internal 3746 Model 900 point-to-point IP connections

For channel, MTU size is not defined in the NCP generation; the IP host passes the MTU size to NCP during the channel XID exchange.

ARP Address Format (starting with NCP V7R1; Token Ring)

Format of the hardware address received in ARP packages. For Token Ring, the ARP address format is defined by the NOTCANON/CANON suboperand of the ARPTAB keyword on the PU statement. The ARP address format can be:

- CANONICAL: Inverted format. In this format, the leftmost byte of the hardware address is transmitted first, and the rightmost bit of each byte is transmitted first.
- NON CANONICAL: Non-inverted format. In this format the leftmost byte of the hardware address is transmitted first, and the leftmost bit of each byte is transmitted first.

Gateway Address (starting with NCP V7R1)

Address of the gateway at the other end of a point-to-point line.

Subnetwork Mask (starting with NCP V7R1)

Subnetwork mask of the interface, which is used to determine the subnetwork portion of a network address. The subnetwork mask is defined by the SNETMASK keyword on:

- The IPLOCAL statement for NCST, Ethernet, and Token Ring
- The PU or IPLOCAL statement for frame-relay, channel, and internal 3746 Model 900 point-to-point IP interfaces.

Metric (starting with NCP V7R1)

A value defined by the METRIC keyword on:

- The IPLOCAL or IPRROUTE statement for NCST, Ethernet, and Token Ring
- The PU, IPLOCAL, or IPRROUTE statement for frame relay, channel, and internal 3746 Model 900 point-to-point IP interfaces

It is used to determine the best possible route when sending a datagram. The number of hops from a source to a destination is the number of gateways in the path. Direct connections have a metric value of one, not zero.

Host IP Owner

Indicator that is displayed when the TCP/IP host connection for this NCP is displayed.

Primary Host IP Owner (starting with NCP V7R6)

The displayed connection is to the primary host IP channel interface owner for this NCP. That is, the interface name is the first or only interface listed on the INTFACE keyword of the IPOWNER statement.

Backup Host IP Owner (starting with NCP V7R6)

The displayed connection is to a backup host IP channel interface owner for this NCP. That is, the interface name is second or later in the list on the INTFACE keyword of the IPOWNER statement.

(blank)

If this area of the screen is blank, the displayed connection is not the TCP/IP host connection for this NCP.

PF Keys

F1=HELP

Displays online help for this panel.

F2=IP STATS

Displays the ATUIS IP Router Statistics Page 1 panel, as shown on page 4-175, to show global counters for IP datagrams and ICMP messages.

F3=RETURN

Returns to the previous NTuneMON panel.

F4=IPLIST

Displays the ATUIL IP Interface Information panel, as shown on page 4-169, to show the local IP interface names and addresses for an NCP.

F5=MODIFY (Token-Ring interfaces)

Available when Interface Type on this panel is Token Ring, the operator has tuning authority, and NTuneNCP is included. For more information, refer to Chapter 5, Using the NTuneNCP Tuning Feature.

Updates the NCP tuning parameter with the modified value. If the modification is not valid, the field turns reverse-video pink, and you are prompted to correct the value and resubmit it.

F6=ROLL

Returns to the NetView command line without exiting NTuneMON. To return to NTuneMON from the NetView program, press F6=ROLL or enter **ATUNEMON** on the NetView command line.

F7=TR IP STATS, ENET STATS, FR IP STATS, CH IP STATS

F7=TR IP STATS (starting with NCP V7R1; Token-Ring interfaces): Displays the ATUTI Token-Ring IP Statistics panel, as shown on page 4-298, to show Token Ring IP statistics.

Note: If you have defined an internal 3746 Model 900 point-to-point IP connection, it is treated as a Token-Ring interface.

F7=ENET STATS (NCP V6R1 or later releases; Ethernet interfaces): Displays the ATUEP Ethernet Adapter List panel, as shown on page 4-81, to show configuration and traffic information on up to 16 Ethernet-type LAN lines. From the ATUEP Ethernet Adapter List panel, you can place the cursor under the line you want to view and press Enter to display the ATUET Ethernet Adapter Statistics panel.

ATUID IP Interface Information Detail Panel

F7=FR IP STATS (starting with NCP V7R3; frame-relay interfaces): Displays the ATUFI Frame-Relay IP Link Statistics panel, as shown on page 4-102, to show IP statistics for this frame-relay line.

F7=CH IP STATS (starting with NCP V7R3; channel interfaces): Displays the ATUCI Channel IP Statistics panel, as shown on page 4-36, to show IP statistics for this channel.

F9=ROUTENT (NCP V7R1 or later releases if a gateway address is defined)
Displays the ATUIR IP Route Table Entries panel, as shown on page 4-172, to show host, network, and subnetwork addresses for a particular destination.

F10=HEX
Displays the ATUDP Hexadecimal Storage Display panel, as shown on page 4-68, to show the local address entry (LAE) control block.

F11=ARP (Token-Ring, Ethernet, frame-relay, and channel interfaces)
Displays the ATUIA ARP Table Entry panel, as shown on page 4-155, to show an ARP entry for this interface.

F12=REFRESH
Refreshes the information on this panel.

PA1=EXIT
Exits NTuneMON.

PA2=LOG
Saves the information on this panel to the NetView log.

ENTER=SEARCH FOR IP ADDRESS
Displays this panel for another IP address. Type in another IP address in the Interface Address field and press Enter.

ATUIL IP Interface Information Panel

Basic fast-path commands: IL, IPLIST

Tuning fields: None

```

ATUIL  A71NT05      IP INTERFACE INFORMATION      NTuneMON V2R1      10:27
                Number of Interface Types
                Ethernet = 0      Frame Relay = 10
                Channel  = 0
NCST      = 1
Token Ring = 0

Interface      Interface Typ Metric  Interface      Interface Typ  Metric
Addresses      Name      Value  Addresses
9.0.0.99      NCSTA01  N      1
10.71.28.99   FRIP0010 F      1
10.71.28.98   FRIP0011 F      1
10.71.28.97   FRIP0012 F      1
10.71.28.96   FRIP0013 F      1
10.71.28.95   FRIP0014 F      1
10.71.28.94   FRIP0015 F      1
10.71.28.93   FRIP0016 F      1
10.71.28.92   FRIP0017 F      1
10.71.28.91   FRIP0018 F      1
10.71.28.90   FRIP0019 F      1
|
=>
F1=HELP F2=IP STATS F3=RETURN F6=ROLL F7=BACK F8=FWD F9=ROUTENT F10=HEX
ENTER=IP INTERFACE INFORMATION DETAIL F11=ARP F12=REFRESH PA1=EXIT PA2=LOG
    
```

Figure 4-48. ATUIL IP Interface Information Panel

Description

The ATUIL IP Interface Information panel, which is available for NCP V6R1 or later releases, displays information about IP interfaces. This panel is also an entry point to the NTuneMON support for IP resources. See Figure 1-6 on page 1-11 for an overview of the panel-to-panel flow within the IP panels.

To display this panel:

- From the ATUCI Channel IP Statistics panel, as shown on page 4-36, press F4.
 - From the ATUTI Token-Ring IP Statistics panel, as shown on page 4-298, press F4.
- Note:** If you have defined an internal 3746 Model 900 point-to-point IP connection, it is treated as a Token-Ring interface.
- From the ATUIS IP Router Statistics Page 1 panel, as shown on page 4-175, press F4.
 - From the ATUIX IP Router Statistics Page 2 panel, as shown on page 4-180, press F4.
 - From the ATUID IP Interface Information Detail panel, as shown on page 4-164, press F4.
 - From the ATUIR IP Route Table Entries panel, as shown on page 4-172, press F4.
 - From the ATUIA ARP Table Entry panel, as shown on page 4-155, press F4.

ATUIL IP Interface Information Panel

- From the ATUFI Frame-Relay IP Link Statistics panel, as shown on page 4-102, press F4.

Fields

NCP name (second field on panel)

Name of the NCP that is currently displayed.

Number of Interface Types

Number of NCST, Ethernet, frame-relay, Token-Ring, and channel interfaces.

Note: If you have defined an internal 3746 Model 900 point-to-point IP connection, it is counted as a Token-Ring interface.

Interface Addresses

Four-byte IP address at the interface as defined by the LADDR keyword on:

- The IPLOCAL statement for NCST, Ethernet, and Token-Ring interfaces
- The PU or IPLOCAL statement for frame-relay, channel, and internal 3746 Model 900 point-to-point IP interfaces

Interface Name (starting with NCP V7R1)

Name of the interface, which must be unique within an NCP generation. For Ethernet and Token-Ring LANs, the interface name is defined by the INTFACE keyword on the LINE statement. For NCST, the interface name is defined by the INTFACE keyword on the LU statement. For frame relay, channel, and internal 3746 Model 900 point-to-point IP interfaces, the interface name is defined by the INTFACE keyword on the PU or IPLOCAL statement.

Typ

Type of interface: N for NCST, E for Ethernet, F for frame relay, T for Token Ring, or C for channel.

Note: If you have defined an internal 3746 Model 900 point-to-point IP connection, it is counted as a Token-Ring interface.

Metric Value (starting with NCP V7R1)

A value defined by the METRIC keyword on the IPLOCAL or IPROUTE statement for NCST, Ethernet, and Token Ring; and the METRIC keyword on the PU, IPLOCAL, or IPROUTE statement for frame relay, channel, and internal 3746 Model 900 point-to-point IP connections. The number of hops along a path from a given source to a given destination is the number of gateways that a datagram encounters along the path. It is used to determine the best possible route when sending a datagram. Direct connections have a metric of one, not zero.

PF Keys

F1=HELP

Displays online help for this panel.

F2=IP STATS

Displays the ATUIS IP Router Statistics Page 1 panel, as shown on page 4-175, to show global counters for IP datagrams and ICMP messages.

F3=RETURN

Returns to the previous NTuneMON panel.

F6=ROLL

Returns to the NetView command line without exiting NTuneMON. To return to NTuneMON from the NetView program, press F6=ROLL or enter **ATUNEMON** on the NetView command line.

F7=BACK

Scrolls the panel data backward one screen.

F8=FWD

Scrolls the panel data forward one screen.

F9=ROUTENT (NCP V7R1 or later releases if a gateway address is defined)

Displays the ATUIR IP Route Table Entries panel, as shown on page 4-172, to show host, network, and subnetwork addresses for a particular destination. Place the cursor under the address you want and press F9.

F10=HEX

Displays the ATUDP Hexadecimal Storage Display panel, as shown on page 4-68, to show the local address entry (LAE) control block. Place the cursor under the interface address you want and press F10.

ENTER=IP INTERFACE INFORMATION DETAIL

Displays the ATUID IP Interface Information Detail panel, as shown on page 4-164, to show detailed information about a specific interface. Place the cursor under the interface address you want and press Enter.

F11=ARP (Token-Ring, Ethernet, frame-relay, and channel interfaces)

Displays the ATUIA ARP Table Entry panel, as shown on page 4-155, to show an ARP entry based on an IP address for a specific interface. Place the cursor under the IP address for the Ethernet, Token-Ring, frame-relay, or channel interface you want to view and press F11.

F12=REFRESH

Refreshes the information on this panel.

PA1=EXIT

Exits NTuneMON.

PA2=LOG

Saves the information on this panel to the NetView log.

ATUIR IP Route Table Entries Panel

Basic fast-path commands: None
 Tuning fields: None

```

ATUIR  A71SUP1      IP Route Table Entries      NTuneMON V2R4      12:27
To display the available routes, enter an IP Destination Address and hit ENTER.
      Destination Address  10.0.0.1
To display the Interface Detail Panel, select an interface address from the
list of routes and hit ENTER.

HOST ROUTE      STATUS METRIC INTERFACE ADDR      NEXT HOP
10.0.0.1        INACT  14      10.0.0.99      N/A

SUBNET ROUTE      STATUS METRIC INTERFACE ADDR      NEXT HOP      SUBNET MASK

NETWORK ROUTE      STATUS METRIC INTERFACE ADDR      NEXT HOP

=>
F1=HELP  F2=IP STATS  F3=RETURN  F4=IPLIST  F6=ROLL  F7=BACK  F8=FWD  F10=HEX
ENTER    F12=REFRESH PA1=EXIT  PA2=LOG
    
```

Figure 4-49. ATUIR IP Route Table Entries Panel

Description

The ATUIR IP Route Table Entries panel, which is available for NCP V7R1 or later releases, displays only the possible route entries based on the destination IP address that is entered.

To display this panel:

- From the ATUIS IP Router Statistics Page 1 panel, as shown on page 4-175, press F9.
- From the ATUIX IP Router Statistics Page 2 panel, as shown on page 4-180, press F9.
- On the ATUIL IP Interface Information panel, as shown on page 4-169, place the cursor under an address and press F9.
- From the ATUID IP Interface Information Detail panel, as shown on page 4-164, press F9.

Fields

NCP name (second field on panel)

Name of the NCP that is currently displayed.

Destination Address

Four-byte IP address of the desired destination. Routes displayed are all host, subnetwork, and network routes that may be used to route datagrams to this destination. See the *NCP, SSP, and EP Resource Definition Guide* for more information about IP addresses. You can type in a different address and press Enter to display routes for that address.

HOST ROUTE

All host route entries that can be used to send datagrams to the specified destination.

SUBNET ROUTE

All subnetwork route entries that can be used to send datagrams to the specified destination.

NETWORK ROUTE

All subnetwork route entries that can be used to send datagrams to the specified destination.

STATUS

Status of the route: ACTIVE or INACTIVE.

METRIC

A value defined by the METRIC keyword on:

- The IPLOCAL or IPRROUTE statement for NCST, Ethernet, and Token Ring
- The PU, IPLOCAL, or IPRROUTE statement for frame relay, channel, and internal 3746 Model 900 point-to-point IP connections.

It is used to determine the best possible route when sending a datagram. The number of hops from a source to a destination is the number of gateways in the path. Direct connections have a metric of one, not zero.

INTERFACE ADDR

Four-byte IP address of the interface used by this route as defined by the LADDR keyword on:

- The IPLOCAL statement for NCST, Ethernet, and Token Ring interfaces
- The PU or IPLOCAL statement for frame-relay, channel, and internal 3746 Model 900 point-to-point IP interfaces

NEXT HOP

IP address of the next gateway for indirect routes.

SUBNET MASK (starting with NCP V7R7)

Subnet mask of the subnetwork route, displayed in IP address format.

PF Keys

F1=HELP

Displays online help for this panel.

F2=IP STATS

Displays the ATUIS IP Router Statistics Page 1 panel, as shown on page 4-175, to show global counters for IP datagrams and ICMP messages.

F3=RETURN

Returns to the previous NTuneMON panel.

F4=IPLIST

Displays the ATUIL IP Interface Information panel, as shown on page 4-169, to show information about an IP interface.

F6=ROLL

Returns to the NetView command line without exiting NTuneMON. To return to NTuneMON from the NetView program, press F6=ROLL or enter **ATUNEMON** on the NetView command line.

ATUIR IP Route Table Entries Panel

F7=BACK

Scrolls the panel data backward one screen.

F8=FWD

Scrolls the panel data forward one screen.

F10=HEX

Displays the ATUDP Hexadecimal Storage Display panel, as shown on page 4-68, to show one of the following, depending on what kind of route the cursor is on when you press Enter:

- Host route entry (HRE) control block for a host route
- Network route entry (NRE) control block for a network route
- Subnetwork route entry (SRE) control block for a subnetwork route.

If the cursor is not on a route when you press Enter, F10=HEX displays the ATUDP Hexadecimal Storage Display panel to show the routing data entry (RDA) control block.

ENTER

Displays one of the following types of information, depending on what you do before pressing Enter:

- Available routes for a destination address, on this panel. Type an IP destination address in the Destination Address field and press Enter.
- Detailed information about an IP interface, on the ATUID IP Interface Information Detail panel, as shown on page 4-164. Place the cursor under an interface address and press Enter.

F12=REFRESH

Refreshes the information on this panel.

PA1=EXIT

Exits NTuneMON.

PA2=LOG

Saves the information on this panel to the NetView log.

ATUIS IP Router Statistics Page 1 Panel

Basic fast-path commands: IP, IS, IPSTAT

Tuning fields: None

```

ATUIS  A04NT02      IP Router Statistics PAGE 1      NTuneMON V2R3      12:22
IP DATAGRAMS      CHANGE      Elapsed Time= 0
Total Received    0 -      ICMP MESSAGES RECEIVED      CHANGE
Bad Checksum RCVD 0 -      Total Received              0 -
Bad Data Lengths  0 -      Received ICMP Error         0 -
Bad Header Lengths 0 -      ICMP Messages Sent
Fragments Received 0 -      Bad Destinations            0 -
Fragments Discarded 0 -      Time Exceeded                0 -
Fragments Timeouts 0 -      Parameter Errors             0 -
Reassembled       0 -      Source Quench                0 -
Forwarded         0 -      Redirected                    0 -
Not Forwarded     0 -      Echo Replies                  0 -
Sent Same as RCVD 0 -      Timestamp Replies            0 -
Fragmented OK     0 -      Address Mask Reply           0 -
Fragmented Failed 0 -      IP Pool is in effect
Fragments Created 0 -      TOTAL      CUR      CUR      THRS
NCP Congestion    0 -      65      0      0%      75%
RCVD Bad Dest Addr 0 -
Time to Live Passed 0 -      IP Rate is in effect
MTU Fragment Bad  0 -      MAX RATE  MAX BURST  CUR RATE
Link Level Brdcst 0 -      25      30      30
=> ATUM017 Press F12 to see Traffic or Polling rates
F1=HELP  F3=RETURN  F4=IPLIST  F6=ROLL  F8=FORWARD  F9=ROUTENT  F10=HEX
F11=NCP FUNCTION  F12=REFRESH  PA1=EXIT  PA2=LOG
    
```

Figure 4-50. ATUIS IP Router Statistics Page 1 Panel

Description

The ATUIS IP Router Statistics Page 1 panel, which is available for NCP V6R1 or later releases, displays global counters for Internet Protocol (IP) datagrams and Internet Control Message Protocol (ICMP) messages. It also shows information on Internet buffer pool use and Internet frame rates. This panel is also an entry point to the NTuneMON support for IP resources. See Figure 1-6 on page 1-11 for an overview of the panel-to-panel flow within the IP panels.

To display this panel:

- From the third PF key selection of the ATUNP NCP Selection panel, as shown on page 4-204, press F9.
- From the second PF key selection of the ATUCD CDS NCP Selection panel, as shown on page 4-27, press F9.
- From the third PF key selection of the ATUNW NCP Wide Selection panel, as shown on page 4-212, press F9.
- From the third PF key selection of the ATUSS Summary Status panel, as shown on page 4-260, press F9.
- From the ATUEP Ethernet Adapter List panel, as shown on page 4-81, press F9.
- From the ATUET Ethernet Adapter Statistics panel, as shown on page 4-84, press F9.
- From the ATUCI Channel IP Statistics panel, as shown on page 4-36, press F2.

- From the ATUTI Token-Ring IP Statistics panel, as shown on page 4-298, press F2.
Note: If you have defined an internal 3746 Model 900 point-to-point IP connection, it is treated as a Token-Ring interface.
- From the ATUIL IP Interface Information panel, as shown on page 4-169, press F2.
- From the ATUID IP Interface Information Detail panel, as shown on page 4-164, press F2.
- From the ATUIR IP Route Table Entries panel, as shown on page 4-172, press F2.
- From the ATUFI Frame-Relay IP Link Statistics panel, as shown on page 4-102, press F2.
- From the ATUIX IP Router Statistics Page 2 panel, as shown on page 4-180, press F7.

Fields

NCP name (second field on panel)

Name of the NCP that is currently displayed.

CHANGE Column

NTuneMON shows two values for each IP DATAGRAM and ICMP MESSAGES counter: the counter value itself and the change since the last time the data was refreshed. The change values, if any, are shown in the CHANGE column and are highlighted in reverse video.

If a change is greater than one per second, the change is shown as a number per second (*n*/SEC). If a change is less than one per second, the actual number is shown.

IP DATAGRAMS

The following counters track datagrams entering and leaving the Internet router, datagrams received with a local NCP address, and datagrams discarded due to NCP congestion:

Total Received

Total number of datagrams received by the Internet router.

Bad Checksum RCVD

Number of datagrams received with bad checksums and discarded.

Bad Data Lengths

Number of datagrams received with invalid data lengths and discarded.

Bad Header Lengths

Number of datagrams received with invalid header lengths and discarded.

Fragments Received

Number of local-address datagram fragments received.

Fragments Discarded

Number of local-address datagram fragments discarded.

Fragments Timeouts

Number of local-address datagrams that timed out and were discarded awaiting reassembly.

Reassembled

Number of local-address datagrams successfully reassembled.

Forwarded

Number of datagrams for other destinations that were forwarded.

Not Forwarded

Number of datagrams not forwarded due to unreachable destinations.

Sent Same as RCVD

Number of datagrams received and transmitted on the same interface.

Fragmented OK

Number of datagrams successfully fragmented.

Fragmented Failed

Number of datagrams discarded because of a failure during fragmentation or because fragmenting was not allowed for those datagrams.

Fragments Created

Number of datagram fragments created.

NCP Congestion

Number of datagrams discarded due to NCP congestion.

RCVD Bad Dest Addr

Number of datagrams received with unknown destination addresses.

Time to Live Passed

Number of datagrams not forwarded because their time to live expired.

MTU Fragment Bad

Number of datagrams discarded due to MTU fragmentation problems.

Link Level Brdcst

Number of link level broadcast messages discarded.

Elapsed Time

Amount of time that has passed since the statistics were last refreshed. This interval is used to calculate the traffic rates, which are displayed in the CHANGE column.

ICMP MESSAGES RECEIVED**Total Received**

Number of ICMP messages received, including those in error or unsupported.

Received ICMP Error

Number of ICMP messages received with ICMP-specific errors.

ICMP Messages Sent**Bad Destinations**

Number of ICMP messages sent indicating unreachable destinations.

Time Exceeded

Number of ICMP messages sent indicating that the time to live was exceeded for a datagram.

Parameter Errors

Number of ICMP messages sent indicating parameter problems.

Source Quench

Number of ICMP source quench messages sent.

Redirected

Number of ICMP redirected messages sent.

Echo Replies

Number of ICMP echo reply messages sent.

Timestamp Replies

Number of ICMP timestamp reply messages sent.

Address Mask Reply

Number of ICMP address mask reply messages sent.

IPPOOL and IPRATE Information

The IP buffer pool (IPPOOL) is the number of NCP buffers that can be used for receiving IP datagrams from Token-Ring and Ethernet-type LANs and from frame-relay, channel, and internal 3746 Model 900 point-to-point IP connections. It is defined by the IPPOOL keyword on the BUILD statement. When the amount of internet data exceeds this limit, IP datagrams are discarded.

TOTAL

Total number of IPPOOL buffers, as defined by the IPPOOL keyword on the BUILD statement.

CUR

Number of IPPOOL buffers in use.

CUR%

Percent of IPPOOL buffers in use.

THRSH%

Alert threshold for IPPOOL buffer use. You can enter a value in this field to change the alert threshold. When the current in-use percentage reaches this value, NTuneMON issues a generic alert (if specified).

If the number of buffers needed for IP datagrams exceeds the number of buffers in the pool, the frames are discarded before being processed by the Internet router.

The following fields provide information on IPRATE.

MAX RATE

Maximum number of Internet frames that can be received continuously into the IP buffer pool per 10th of a second, as defined by the IPRATE keyword on the BUILD statement. If IP datagrams arrive faster than this rate for longer than a 10th of a second, IP datagrams are discarded.

MAX BURST

Maximum number of Internet frames that can be received in a burst of a 10th of a second, as defined by the IPRATE keyword on the BUILD statement.

CUR RATE

Current rate at which Internet frames are being received into the IP buffer pool, shown as the number of frames per 10th of a second.

PF Keys

F1=HELP

Displays online help for this panel.

F3=RETURN

Returns to the previous NTuneMON panel.

F4=IPLIST

Displays the ATUIL IP Interface Information panel, as shown on page 4-169, to show the local IP interface names and addresses for an NCP.

F6=ROLL

Returns to the NetView command line without exiting NTuneMON. To return to NTuneMON from the NetView program, press F6=ROLL or enter **ATUNEMON** on the NetView command line.

F8=FORWARD (NCP V7R1 or later releases if a gateway address is defined)

Scrolls forward to the ATUIX IP Router Statistics Page 2 panel, as shown on page 4-180.

F9=ROUTENT (NCP V7R1 or later releases if a gateway address is defined)

Displays the ATUIR IP Route Table Entries panel, as shown on page 4-172, to show host, network, and subnetwork addresses for a particular destination.

F10=HEX

Displays the ATUDP Hexadecimal Storage Display panel, as shown on page 4-68, to show the internet protocol router statistics (IPS) control block.

F11=NCP FUNCTION

Displays the ATUST NCP Function Activation panel, as shown on page 4-269, to show information about snap traces for NTRI, ODLC, and IP resources. Use the snap trace under the direction of your IBM service representative.

F12=REFRESH

Refreshes the information on this panel.

PA1=EXIT

Exits NTuneMON.

PA2=LOG

Saves the information on this panel to the NetView log.

ATUIX IP Router Statistics Page 2 Panel

Basic fast-path commands: None
 Tuning fields: None

```

ATUIX  A04NT02      IP Router Statistics Page 2      NTuneMON V2R3      12:22
Elapsed Time= 0
UDP DATAGRAMS      CHANGE | Owing TCP/IP Host Address
Total Received      0 - | 8.0.0.1
Add Route Requests  0 - |
Delete Route Requests 0 - | Address of Interface to
Change Route Requests 0 - | Owing TCP/IP Host
Undetermined Requests 0 - | 8.0.0.99
Unprocessed ADD Requests 0 - |
Unprocessed DEL Requests 0 - | UDP Port Number 17
Unprocessed CHG Requests 0 - | Routing Table Name A04NT02P
Active Interface Changes 0 - |
Inactive Interface Changes 0 - | Communication Established NO
RIP Broadcast Frames 0 - | Hello Backoff Active NO
SNMP Broadcast Frames 0 - | Hello Threshold Defined YES
Lost Owing Host      0 - | Hello Threshold Reached NO
Bad UDP Checksum      0 - |
Datagrams Ports Unknown 0 - | Cur Maximum
UDP Discarded(congestion) 0 - | Hello Hello Warning
UDP Discarded(no owner) 0 - | Value Value Threshold
                                | 4 0006 80%
=> ATUM017 Press F12 to see Traffic or Polling rates
F1=HELP F3=RETURN F4=IPLIST F6=ROLL F7=BACKWARD F9=ROUTENT F10=HEX
F11=NCP FUNCTION F12=REFRESH PA1=EXIT PA2=LOG
    
```

Figure 4-51. ATUIX IP Router Statistics Page 2 Panel

Description

The ATUIX IP Router Statistics Page 2 panel, which is available for NCP V7R1 or later releases, displays global counters for User Datagram Protocol (UDP) datagrams. It also displays information about initiating communications with the owning TCP/IP host.

To display this panel: On the ATUIS IP Router Statistics Page 1 panel, as shown on page 4-175, press F8.

Fields

NCP name (second field on panel)

Name of the NCP that is currently displayed.

Elapsed Time

The amount of time that has passed since the statistics were last refreshed. This interval is used to calculate the traffic rates, which are displayed in the CHANGE column.

CHANGE Column

NTuneMON shows two values for each UDP DATAGRAM counter: the counter value itself and the change since the last time the data was refreshed. The change values, if any, are shown in the CHANGE column and are highlighted in reverse video.

If a change is greater than one per second, the change is shown as a number per second (n/S). If a change is less than one per second, the actual number is shown.

UDP DATAGRAMS

The following counters track UDP datagrams:

Total Received

Total number of UDP datagrams received since the NCP became active.

Add Route Requests

Number of Add Route Requests received from NCPROUTE since the NCP became active. Used for adding a new host, network, or subnetwork route. Also used for changing a route currently in the routing table(s) without sending a Delete and Add Route Request pair.

Delete Route Requests

Number of Delete Route Requests received from NCPROUTE since the NCP became active. Used to remove a route no longer known to the network.

Change Route Requests

Number of Change Route Requests received from NCPROUTE since the NCP became active. Used to change the metric value for a host, network, or subnetwork route.

Undetermined Requests

Number of requests received that require action unknown to the NCP.

Unprocessed Requests

Number of Add, Delete, or Change Requests that could not be processed since this NCP became active.

Active Interface Changes

Number of Interface Status datagrams sent by NCP indicating that an NCST, Ethernet, Token-Ring, frame-relay, channel, or internal 3746 Model 900 point-to-point IP interface has become active.

Inactive Interface Changes

Number of Interface Status datagrams sent by NCP indicating that an NCST, Ethernet, Token-Ring, frame-relay, channel, or internal 3746 Model 900 point-to-point IP interface has become inactive.

RIP Broadcast Frames

Number of RIP frames received and forwarded to NCPROUTE since the NCP became active. These numbers only reflect those frames received while communication with NCPROUTE is established.

SNMP Broadcast Frames

Number of SNMP frames received and forwarded to NCPROUTE since the NCP became active. These numbers only reflect those frames received while communication with NCPROUTE is established.

Lost Owning Host

Number of times the NCP entered reset state due to the loss of communication with the NCPROUTE host.

Bad UDP Checksum

Number of times the NCP entered reset state due to a UDP datagram received from the owning host with an invalid checksum.

Datagrams with Port Unknown

Number of datagrams received with an unknown destination port.

UDP Discarded(congestion)

Number of datagrams discarded due to NCP congestion.

UDP Discarded(no owner)

Number of datagrams discarded because NCPROUTE support is not included in the gen.

Owning Host Information (right side of panel)

All of these fields contain "N/A" if NCPROUTE support is not included in the gen.

Owning TCP/IP Host Address

Address of the current owning TCP/IP host.

Address of Interface to Owning TCP/IP Host

Interface address of the current owning TCP/IP host.

UDP Port Number

Port number used for communication between the NCP internet router and NCPROUTE server of the owning host. This number must match the port number used by NCPROUTE. Defined by the UDPPORT keyword on the IPOWNER statement.

Routing Table Name

Name of the routing information table on the owning TCP/IP host that contains this NCP's generated interface and route information.

Communication Established

YES or NO to indicate whether communication is established with the owning TCP/IP host.

Hello Backoff Active

YES or NO to indicate whether NCP has sent a Hello Threshold Reached alert and is waiting nine minutes before starting the sequence again.

Hello Threshold Defined

YES or NO to indicate whether a threshold has been defined for the number of datagrams that can be sent without an acknowledgement before an alert (if specified) is issued. This threshold is defined by the MAXHELLO keyword on the IPOWNER statement. Once the threshold is reached, NCP sends an alert (if specified) and waits nine minutes before starting the sequence again. If MAXHELLO is coded as NONE, an alert will not be sent.

Hello Threshold Reached

YES or NO to indicate whether the Hello threshold has been reached.

Cur Hello Value

Number of datagrams sent with no acknowledgement. When this value reaches the Maximum Hello Value, it is displayed in reverse-video red.

Maximum Hello Value

Hello Threshold as defined by the MAXHELLO keyword on the IPOWNER statement.

Warning Threshold

Alarm threshold for the Maximum Hello Value. You can enter a value to change the threshold. NTuneMON issues a generic alert (if specified) when the number of datagrams sent with no acknowledgement reaches this percentage of the Maximum Hello Value.

PF Keys

F1=HELP

Displays online help for this panel.

F3=RETURN

Returns to the previous NTuneMON panel.

F4=IPLIST

Displays the ATUIL IP Interface Information panel, as shown on page 4-169, to show the IP interface names and addresses for an NCP.

F6=ROLL

Returns to the NetView command line without exiting NTuneMON. To return to NTuneMON from the NetView program, press F6=ROLL or enter **ATUNEMON** on the NetView command line.

F7=BACK

Scrolls back to the ATUIS IP Router Statistics Page 1 panel, as shown on page 4-175.

F9=ROUTENT (starting with NCP V7R1)

Displays the ATUIR IP Route Table Entries panel, as shown on page 4-172, to show host, network, and subnetwork addresses for a particular destination.

F10=HEX

Displays the ATUDP Hexadecimal Storage Display panel, as shown on page 4-68, to show the internet protocol router statistics (IPS) control block.

F11=NCP FUNCTION

Displays the ATUST NCP Function Activation panel, as shown on page 4-269, to show information about snap traces for NTRI, ODLC, and IP resources. Use the snap trace under the direction of your IBM service representative.

F12=REFRESH

Refreshes the information on this panel.

PA1=EXIT

Exits NTuneMON.

PA2=LOG

Saves the information on this panel to the NetView log.

ATUML Multi-Link Transmission Group Panel

Basic fast-path commands: None

Tuning fields: (TG THRS) LOW, MED, HIGH, TOTAL, PRI, QUED LMT

```

ATUML                               Multi-Link Transmission Group      NTuneMON V2R1  14:57
NCP= A04NT06  SUB= 4                NCP= A71NT06  SUB= 71
TGN= 1      NET= NETA                 TGN= 1      NET= NETA
MAX Transfer= 6984                    MAX Transfer= N/A
Outbound SEQ= 001                     Outbound SEQ= N/A
Inbound SEQ= 001                      Inbound SEQ= N/A
Transmit QUE= 0                       Transmit QUE= N/A
----- HIGH PERFORMANCE ROUTING -----
BYTES =          0  QUED LMT= 20000   BYTES =          0  QUED LMT=
DISCARDED FID4S  RXD=0      TXD=0     DISCARDED FID4S  RXD=      TXD=
TG:  LOW:  MED:  HIGH:  TOTAL         TG:  LOW:  MED:  HIGH:  TOTAL
CUR=   0    0    0    0              CUR= N/A   N/A   N/A   N/A
THRS= 5000 5000 5000 20000         THRS= N/A  N/A  N/A  N/A

PRI LINE  PU      TYPE  STATUS      PRI LINE  PU      TYPE  STATUS
 0 A04TR88 A04LP08 16MTIC2 ACTIVE    0
 0 A04F0003 A04LP10 FRTSS   ACTIVE    0
 0 A04F0003 A04LP11 FRTSS   ACTIVE    0
 0 A04F0003 A04LP12 FRTSS   ACTIVE    0
 0 A04F0003 A04LP13 FRTSS   ACTIVE    0

=>
F1=HELP F3=RETURN F5=MODIFY F6=ROLL F7=BACK F8=FORWARD F10=HEX F12=REFRESH
PA1=EXIT PA2=LOG  ENTER=Fill in destination MLTG data
    
```

Figure 4-52. ATUML Multi-Link Transmission Group Panel

Description

The ATUML Multi-Link Transmission Group panel displays information on a multi-link transmission group. The left side of the panel displays information on the origin NCP, and the right side displays information on the destination NCP.

Note: Information on the destination NCP is displayed only if that NCP is activated by the host in which NTuneMON is running.

To display this panel:

- From the ATUTG Transmission Group panel, as shown on page 4-294, place the cursor under a transmission group and press Enter.
- From the ATUTL Token-Ring SNA Station panel, as shown on page 4-301, press Enter.
- From the ATUSD SDLC Station Details panel, as shown on page 4-241, press Enter.
- From the ATUFT1 Frame Relay Terminating Equipment Details Page 1 panel, as shown on page 4-135, or from the ATUFT2 Frame Relay Terminating Equipment Details Page 2 panel, as shown on page 4-143, press Enter.

Fields

The following fields are displayed for both the origin NCP (shown on the left side of the panel) and the destination NCP (shown on the right side of the panel).

NCP

Name of the NCP that is currently displayed.

SUB

Subarea address as defined by the SUBAREA keyword on the BUILD statement.

OUT OF SEQ

This message appears to the right of the SUB field when PIUs have arrived out of sequence. When this happens, the NCP queues them internally and puts them back in the correct order.

TGN

Transmission group number.

NET

Network identifier. Active defined networks on this panel are displayed in blue. Active dynamic networks are displayed in yellow.

TGCONF=MULTI

This message appears to the right of the NET field when this transmission group contains only one line but was defined with TGCONF=MULTI on the PU statement for the link station. You can improve NCP performance for a single-link transmission group by defining the link station with TGCONF=SINGLE.

MAX Transfer

Maximum segment size for the transmission group. For more information on maximum segment size, refer to the discussion of multilink transmission groups in *NCP, SSP, and EP Resource Definition Guide*.

Outbound SEQ and Inbound SEQ

Sequence number for the current outbound and inbound PIUs, and the outbound and inbound traffic rates.

Sequence numbers are displayed in reverse-video turquoise to show that they have changed since the panel was entered or since the last time F12 was pressed.

The traffic rate is calculated by the number of frames sent or received since the panel was entered or since the last time F12 was pressed.

If the traffic rate is greater than one frame per second, NTuneMON displays the rate in reverse-video yellow in frames per second (*n/S*). If the rate is less than one frame per second, NTuneMON displays the actual number of frames sent and received in yellow. If the rate is zero, no traffic rate is displayed.

Note: The traffic rate might be inaccurate the first time you press F12=REFRESH after a long delay.

Transmit QUE (starting with NCP V6R2)

Number of PIUs waiting to be transmitted.

High Performance Routing

BYTES (starting with NCP V7R3)

Number of bytes of HPR data that is queued to the MLTG transmit queue.

QUED LMT (starting with NCP V7R3)

Maximum number of bytes allowed to be queued to the MLTG's transmit queue, as defined by the *totthresh* suboperand of the ERn keyword on the PATH statement.

DISCARDED FID4s (starting with NCP V7R3)

Number of HPR FID4s received or to be transmitted that have been discarded.

RXD

Number of received HPR FID4s discarded because of node congestion.

TXD

Number of HPR FID4s to be transmitted which were instead discarded because of queue overrun.

TG

Transmission group.

LOW MED HIGH TOTAL

Current (CUR) size in bytes for low, medium, and high priority for PIUs in the outbound queue, as defined by the *lothresh*, *medthresh*, *totthresh*, and *hithresh* suboperands, respectively, of the ERn keyword on the PATH statement.

Flow-control threshold (THRS) for low-priority, medium-priority, and high-priority PIUs transmitted over this transmission group.

When these thresholds are exceeded, congestion indicators are set in PIUs going over the transmission group in the opposite direction until the congestion clears up.

The following columns on this panel display information on individual lines in the transmission group. This information is always displayed for the origin NCP. Press Enter to display this information for the destination NCP.

PRI

Priority of the link in the MLTG, as defined by the MLTGPRi keyword on the LINE statement.

If this NCP selects lines by order of activation instead of line priority (MLTGORDR=FIFO on the BUILD statement), this column displays 0 for all lines.

Numbers are prioritized from high to low. If the numbers are the same, the line that is activated first has priority.

LINE

Physical line name.

PU (starting with NCP V6R2)

Link station LU name.

TYPE

Line type and speed. This can be any of the following:

TSS Low-speed SDLC line.

HPTSS High-speed SDLC line.

SDLC (starting with NCP V5R4) Low-speed or high-speed SDLC line.

CLP (NCP V6R3 or later releases) 3746 Model 900 SDLC line on a communication line processor.

DIAL Switched SDLC line.

Note: For switched CLP lines, TYPE is CLP (not DIAL).

sMTICt Token-Ring line. **s** indicates the Token-Ring speed in megabits per second (Mbps), and **t** indicates the TIC type. For example, 4MTIC2 indicates a 4-Mbps Token Ring attached to a type 2 TIC.

FRTSS Low-speed frame-relay line.

FRHPTSS High-speed frame-relay line.

STATUS

Line status. This can be any of the following:

ACTIVE

The line is active and ready to send data. This condition is highlighted in reverse-video green.

ACT/XMIT

The line is active but not available for traffic. This condition is highlighted in reverse-video yellow. This condition can occur when the line is busy. NCP will attempt to use the next line in the transmission group.

ACT/ERP

The line is in error recovery. This condition is highlighted in reverse-video pink.

PF Keys

F1=HELP

Displays online help for this panel.

F3=RETURN

Returns to the previous NTuneMON panel.

F5=MODIFY

Available when the operator has tuning authority and NTuneNCP is included. For more information, refer to Chapter 5, Using the NTuneNCP Tuning Feature.

Updates the NCP tuning parameter with the modified value. If the modification is not valid, the field turns reverse-video pink, and you are prompted to correct the value and resubmit it.

F6=ROLL

Returns to the NetView command line without exiting NTuneMON. To return to NTuneMON from the NetView program, press F6=ROLL or enter **ATUNEMON** on the NetView command line.

F7=BACK

Scrolls the panel data backward one screen.

F8=FORWARD

Scrolls the panel data forward one screen.

ATUML Multi-Link Transmission Group Panel

F10=HEX

Displays the ATUDP Hexadecimal Storage Display panel, as shown on page 4-68, to show the multilink transmission group control block (FLB) for the origin or destination NCP. Place the cursor in the half of the panel for the NCP you want to view and press F10.

F12=REFRESH

Refreshes the information on this panel.

PA1=EXIT

Exits NTuneMON.

PA2=LOG

Saves the information on this panel to the NetView log.

ENTER=FILL IN DESTINATION MLTG DATA

Displays line-specific information for the destination NCP. The destination NCP is found as follows: If the PUNAME and NEWNAME keywords on the BUILD statement are not equal, a search is made using PUNAME. If PUNAME is not found, a search is made using NEWNAME.

Destination data is filled in on the right half of the panel only when the destination NCP was activated on the host in which NTuneMON is running.

After you press Enter the first time, ENTER= has the same function as F12=REFRESH.

ATUMT Modify Timer Value Panel

Basic fast-path commands: NONE

Tuning fields: REPLYTO, RETRYTO, TEXTTO, XMITDLY

```

ATUMT  A71NT05          Modify Timer Value          NTuneMON V2R1  07:34
-----
Timer Value Select Table (TVS)
Time-out Value (in seconds) for REPLYTO = 60.0
-----
| 1.  NONE | 2.  0.0 | 9.  6.5 | 10. 30.0 |
|-----|-----|-----|-----|
| 3.  1.0 | 4.  2.2 | 11. 0.1 | 12. █████ |
|-----|-----|-----|-----|
| 5.  3.0 | 6. 23.5 | 13.    | 14.    |
|-----|-----|-----|-----|
| 7. 60.0 | 8.  4.2 | 15.    | 16.    |
|-----|-----|-----|-----|
=>
F1=HELP  F3=RETURN  F4=SELECT TIMER,RETURN  F5=MODIFY  F6=ROLL  F10=HEX
F12=REFRESH  PA1=EXIT  PA2=LOG
    
```

Figure 4-53. ATUMT Modify Timer Value Panel

Description

The ATUMT Modify Timer Value panel, which is available for NCP V7R2 or later releases, displays information about time out values, in seconds, for the time value select (TVS) control block. This panel is also used to enter new timer values for a particular keyword. All defined entries are displayed in white.

To display this panel: On the ATUSP2 SDLC Peripheral Line Parameters Page 2 panel, as shown on page 4-255, place the cursor under the REPLYTO, RETRYTO, TEXTTO, or XMITDLY keyword and press F9.

Fields

NCP name (second field on panel)

Name of the NCP that is currently displayed.

Time-out Value (in seconds) for nn = vv.v

Displays timer values vv.v for timer keyword nn, the timer whose values are being modified. The timer keywords whose timer values can be modified using the ATUMT Modify Timer Value panel are:

- REPLYTO
- RETRYTO
- TEXTTO
- XMITDLY

The current value of the keyword, as well as its matching value in the corresponding timer entry, is displayed in pink.

The following paragraphs describe the parameters for each timer.

ATUMT Modify Timer Value Panel

REPLYTO

Specifies the reply time out value or values in seconds, for the line. If NCP or EP does not receive a response to a poll, selection, or message text before specified time expires, a time out error is indicated and the appropriate error recovery procedure is started.

For a switched SDLC line, NCP uses the interval specified by XMITDLY on this GROUP definition statement as the reply time out value during initial XID exchange. In other cases, NCP uses the value of REPLYTO as defined in the GROUP definition statement.

RETRYTO

Specifies, in seconds, how long NCP is to wait after receiving a retry call progress signal (CPS) before retrying a call out, as defined in the RETRYTO keyword on the GROUP definition statement.

TEXTTO

Specifies the text time out value, in seconds, for the line, as defined in the TEXTTO keyword on the GROUP definition statement.

XMITDLY

Specifies, in seconds, how long NCP is to delay its initial transmission after answering an incoming call.

The value of XMITDLY is used as the reply time out value during initial XID exchange as defined in the XMITDLY keyword on the GROUP definition statement.

Time out Values (in seconds)

Timer entry containing *nn.n*

nn.n specifies defined entries.

nn.n is also the time out value in seconds.

Timer entry containing a reverse-video turquoise box

The first available entry for modifying. This entry is displayed in reverse-video turquoise.

If no entry is shown in reverse-video turquoise, all entries are already defined and no new values can be added.

If the first available entry is updated, it is used in association with the keyword displayed.

Blank timer entry

The timer entries which are blank represent available timer entries. At a particular time, only the first available entry is modifiable.

PF Keys

F1=HELP

Displays online help for this panel.

F3=RETURN

Returns to the previous NTuneMON panel.

F4=SELECT TIMER,RETURN

Available when the operator has tuning authority and NTuneNCP is included.

Returns you to the ATUSP2 SDLC Peripheral Line Parameters Page 2 panel. The value you selected on the ATUMT Modify Timer Value panel is now on

the ATUSP2 SDLC Peripheral Line Parameters Page 2 panel, as shown on page 4-255. A message appears indicating that the timer value was successfully verified. It has not, however, been modified yet. When you press F4=MODIFY,ACT or F5=MODIFY from either the ATUSP1 SDLC Peripheral Line Parameters Page 1 or the ATUSP2 SDLC Peripheral Line Parameters Page 2 panel, the new timer value will be modified in conjunction with any other changes you might have made on the ATUSP1 SDLC Peripheral Line Parameters Page 1 and ATUSP2 SDLC Peripheral Line Parameters Page 2 panels.

F5=MODIFY

Available when the operator has tuning authority and NTuneNCP is included.

Adds a permanent timer value to an existing entry in NCP's timer value select (TVS) control block. The value appears as a defined value on this panel. A warning message appears indicating that the timer value is a permanent entry and you are prompted to type *Y* or *N* to either accept or reject the value.

Note: You are only allowed to create sixteen entries for each timer. Once an entry is created, no new timer values can be added. You cannot duplicate entries. Before creating a new entry, examine closely the existing entries to see if one of them can be used instead of creating a new one.

F6=ROLL

Returns to the NetView command line without exiting NTuneMON. To return to NTuneMON from the NetView program, press F6=ROLL or enter **ATUNEMON** on the NetView command line.

F10=HEX

Displays the ATUDP Hexadecimal Storage Display panel, as shown on page 4-68, to show the TVS.

F12=REFRESH

Refreshes the information on this panel.

PA1=EXIT

Exits NTuneMON.

PA2=LOG

Saves the information on this panel to the NetView log.

ATUNA GWNAU Names and HSCBs Panel

Basic fast-path commands: NA, NAUS, GWNAU, GWNAUS

Tuning fields: None

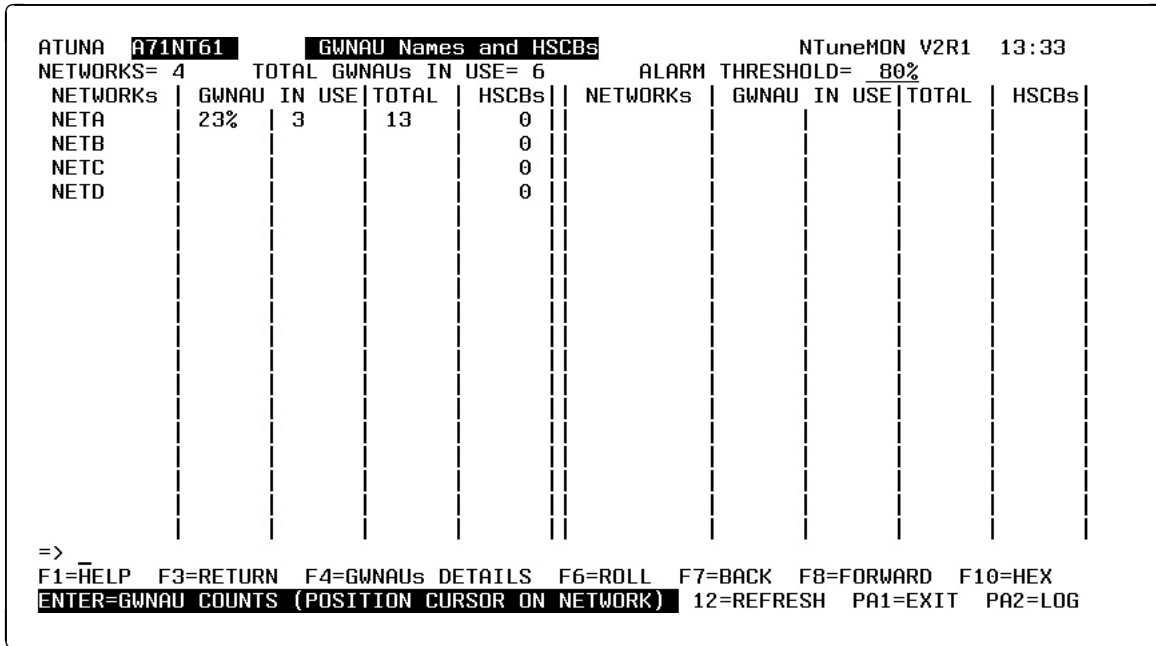

Figure 4-54. ATUNA GWNAU Names and HSCBs Panel

Description

The ATUNA GWNAU Names and HSCBs panel, which is available for NCP V6R1 or earlier releases, displays information on the use of gateway network addressable units (GWNAUs).

Two GWNAUs are used for each cross-network SNI session and can be shared among different sessions with the same primary logical unit (PLU). GWNAU names are defined on the NCP GWNAU statement. Figure 4-55 shows the use of GWNAUs and HSCBs in a gateway NCP.

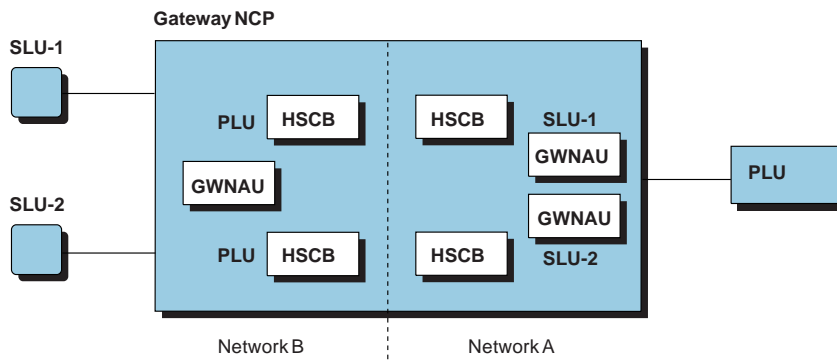

Figure 4-55. GWNAUs and HSCBs in a Gateway NCP

Place the cursor under a network name and press F4 or Enter for detailed information on GWNAUs for that network.

This analysis can take a long time to run and can use a large amount of NetView storage and processing time.

To display this panel: On the ATUNN HSCBs (Networks and HSCB Counts) panel, as shown on page 4-201, place the cursor under the name of a network and press F4.

Fields

NCP name (second field on panel)

Name of the NCP that is currently displayed. You can enter a different NCP name in this field to display information about another NCP.

NETWORKS

Total number of SNI networks.

TOTAL GWNAUs IN USE

Total number of GWNAUs in use for all networks.

ALARM THRESHOLD

Alarm threshold for GWNAU use. You can enter a value in this field to change the alarm threshold. NTuneMON issues a generic alert (if specified) when the number of GWNAUs in use for a network reaches this percentage of the total number of GWNAUs defined for that network.

A shortage of GWNAUs can cause session activation to fail with an insufficient resource sense code. If the total number of GWNAUs in use nears the alarm threshold, increase the number of GWNAUs, which is defined by the NUMADDR keyword on the GWNAU statement.

The following columns on this panel show information for each network.

NETWORKs

Names of the SNI cross networks.

To refresh the following fields for a specific network, place the cursor under the name of the network and press F12=REFRESH.

GWNAU IN USE

Use of GWNAUs for a particular network, shown as both the number of GWNAUs in use and the percentage of the total number of GWNAUs defined for the network.

TOTAL

Total number of GWNAUs defined for a particular network.

HSCBs

Number of HSCBs in use for a particular network.

PF Keys

F1=HELP

Displays online help for this panel.

F3=RETURN

Returns to the previous NTuneMON panel.

F4=GWNAU DETAILS

Displays the ATUIB GWNAUs in Use Counts panel as shown on page 4-158, to show the GWNAUs in use for a particular network. Place the cursor under the network you want to view and press F4.

Note: Performing this analysis interactively can take a long time. Instead, you might want to perform this analysis by starting NTuneMON with OUTPUT=LINE and TYPE=GWNAUD. TYPE=SUMMARY does not include the GWNAU analysis.

F6=ROLL

Returns to the NetView command line without exiting NTuneMON. To return to NTuneMON from the NetView program, press F6=ROLL or enter **ATUNEMON** on the NetView command line.

F7=BACK

Scrolls the panel data backward one screen.

F8=FORWARD

Scrolls the panel data forward one screen.

ENTER=GWNAU COUNTS (POSITION CURSOR ON NETWORK)

Displays information on GWNAU use for a particular network from node initialization block (NIB) control block statuses. Place the cursor under the network you want to view and press Enter.

F10=HEX

Displays the ATUDP Hexadecimal Storage Display panel, as shown on page 4-68, to show the network vector table (NVT).

F12=REFRESH

Refreshes information on GWNAU use for a particular network from node initialization block (NIB) control block statuses. Place the cursor under the network you want to view and press F12.

PA1=EXIT

Exits NTuneMON.

PA2=LOG

Saves the information on this panel to the NetView log.

ATUNG HSCBs and GWNAUs Panel

Basic fast-path commands: GWNAU, GWNAUS, NG, NAUS,
Tuning fields: None

```

ATUNG A27GENC          HSCBs and GWNAUs          NTuneMON V2R6  14:27
HSCBs (IN USE= 0     PERCENT IN USE=  0% )      GWNAU ALARM=  80%
ACTIVE NETWORKS= 1   FREE NETWORKS=  0

```

		(H S C B)			(G W N A U)			
NETWORKs	SUB	INUSE	LIMIT	INUSE	MAX	INUSE	MAX	TOTAL
NETA	27	0	0	0%	0%	0	0	0

```

=>
F1=HELP F2=NETPOOLS F3=RETURN F4=DETAILS F6=ROLL F7=BACK F8=FORWARD
F9= VR/TG Alert Timers F10=HEX F12=REFRESH PA1=EXIT PA2=LOG

```

Figure 4-56. ATUNG HSCBs and GWNAUs Panel

Description

The ATUNG HSCBs and GWNAUs panel, which is available for NCP V6R2 or later releases, displays information on the use of HSCBs and GWNAUs for an NCP. This panel combines the information from both the ATUNN HSCBs (Networks and HSCB Counts) panel and the ATUNA GWNAU Names and HSCBs panel, and requires less time to perform the GWNAU names analysis than those panels.

To display this panel:

- From the first PF key selection of the ATUNP NCP Selection panel, as shown on page 4-204, press F4.
- From the third PF key selection of the ATUCD CDS NCP Selection panel, as shown on page 4-27, press F4.
- From the first PF key selection of the ATUNW NCP Wide Selection panel, as shown on page 4-212, press F4.
- From the first PF key selection of the ATUSS Summary Status panel, as shown on page 4-260, press F4.
- From the ATUCB Control Block Pools/Tables panel, as shown on page 4-17, press F4.
- From the ATUBP NCP Buffer Pool panel, as shown on page 4-4, press F4.

Fields

NCP name (second field on panel)

Name of the NCP that is currently displayed. You can enter a different NCP name in this field to display information about another NCP.

HSCBs IN USE

Total number of HSCBs (NIX/NLX pairs) in use per network.

IN USE

Number of HSCBs currently in use and percentage of the maximum total number of HSCBs currently in use.

PERCENT IN USE

Percentage of maximum total number of HSCBs currently in use.

Total number of SNI cross networks.

ACTIVE NETWORKS

Number of networks in use (active) (excluding the model network). A model network is a template for a network definition. For more information, see the COPIES keyword in *NCP, SSP, and EP Resource Definition Reference*.

FREE NETWORKS

Number of networks not in use (free) (excluding the model network). A model network is a template for a network definition. For more information see the COPIES keyword in *NCP, SSP, and EP Resource Definition Reference*.

GWNAU ALARM

Alarm threshold for GWNAU use. You can enter a value in this field to change the alarm threshold. NTuneMON issues a generic alert (if specified) when the number of GWNAUs in use for a network reaches this percentage of the total number of GWNAUs defined for that network.

A shortage of GWNAUs can cause session activation to fail with an insufficient resource sense code. If the total number of GWNAUs in use nears the alarm threshold, increase the number of GWNAUs, which is defined by the NUMADDR keyword on the GWNAU statement.

For NCP V7R1 or later releases: You can use the dynamic control block (CB) function to alter NUMADDR for GWNAUs. See *NCP and EP Reference* for more information.

The following columns on this panel show HSCB use for each network.

NETWORKs

Network names of active networks only. Network names are color-coded as follows:

Turquoise Non-Dynamic network

Yellow Dynamic network, a network that can be modified without operator intervention

SUB

Adjacent subarea address.

INUSE

Number of HSCBs currently in use for each network. This count is the number of cross-network SNI sessions through a gateway NCP.

LIMIT

Maximum number of HSCBs that can be used for the network, as defined by the NETLIM keyword on the BUILD or NETWORK statement.

The following columns on this panel show GWNAU use for each network.

INUSE

The first INUSE field shows the percentage of GWNAUs currently in use. The second INUSE field shows the number of GWNAUs currently in use.

MAX

The first MAX field shows the highest percentage of GWNAUs in use since this NCP was loaded. If the value of the percentage field exceeds 100 percent, the field is highlighted in reverse-video pink. The second MAX field shows the number of GWNAUs in use since the NCP was loaded.

TOTAL

Total number of GWNAUs defined for this network. This total is per network and does not include cross networks or GWNAUs that are permanently assigned. For this information, see "ATUGP Network CB Pools/Tables Panel" on page 4-149.

PF Keys

F1=HELP

Displays online help for this panel.

F2=NETPOOLS (starting with NCP V7R1)

Displays the ATUGP Network CB Pools/Tables panel, as shown on page 4-149, which shows the control block pool/table data for a particular network. Place the cursor under the name of the network you want to view and press F2.

F3=RETURN

Returns to the previous NTuneMON panel.

F4=DETAILS

Displays one of the following panels, which shows the GWNAUs in use for a particular network:

- For NCP V7R1 or later releases, the ATUIC Non-Dynamic GWNAUs in Use Counts panel, as shown on page 4-161, is displayed.
- For NCP releases before NCP V7R1, the ATUIB GWNAUs in Use Counts panel, as shown on page 4-158, is displayed.

Place the cursor under the name of the network you want to view and press F4.

Note: Performing this analysis interactively can take a long time. Instead, you might want to perform this analysis by starting NTuneMON with OUTPUT=LINE and TYPE=GWNAU. TYPE=SUMMARY does not include the GWNAU analysis.

F6=ROLL

Returns to the NetView command line without exiting NTuneMON. To return to NTuneMON from the NetView program, press F6=ROLL or enter **ATUNEMON** on the NetView command line.

F7=BACK

Scrolls the panel data backward one screen.

ATUNG HSCBs and GWNAUs Panel

F8=FORWARD

Scrolls the panel data forward one screen.

F9=VR/TG Alert Timers

Displays the ATUVT VR Alert Timer panel, to show the virtual route timer values and the TG timer values for the network. Place the cursor under the name of a network and press F9.

F10=HEX

Displays the ATUDP Hexadecimal Storage Display panel, as shown on page 4-68, to show the network vector table (NVT).

F12=REFRESH

Refreshes the information on this panel.

PA1=EXIT

Exits NTuneMON.

PA2=LOG

Saves the information on this panel to the NetView log.

ATUNI NTuneNCP Information Panel

NTuneNCP

NTuneNCP Feature or NTuneNCP V1R1.

NTuneNCP Trace Modify Table

ADDRESS

NCP storage addresses that were modified by NTuneNCP.

BYTES

Number of bytes of NCP storage at each address that were modified by NTuneNCP.

PF Keys

F1=HELP

Displays online help for this panel.

F3=RETURN

Returns to the previous NTuneMON panel.

F6=ROLL

Returns to the NetView command line without exiting NTuneMON. To return to NTuneMON from the NetView program, press F6=ROLL or enter **ATUNEMON** on the NetView command line.

F7=BACK

Scrolls the panel data backward one screen.

F8=FWD

Scrolls the panel data forward one screen.

F10=HEX

Displays the ATUDP Hexadecimal Storage Display panel, as shown on page 4-68, to show the NTT control block.

F12=REFRESH

Refreshes the information on this panel.

PA1=EXIT

Exits NTuneMON.

PA2=LOG

Saves the information on this panel to the NetView log.

ATUNN HSCBs (Networks and HSCB Counts) Panel

Basic fast-path commands: NN, HSCB, HSCBS

Tuning fields: None

ATUNN		A71NT54		HSCBs (Networks and HSCB Counts)				NTuneMON V2R1		13:23	
NETWORKS=		1		TOTAL HSCBS		IN USE=		0		ALARM THRESHOLD= 80%	
NETWORK	SUBAREA	CUR-HSCB	MAX-HSCB	NETWORK	SUBAREA	CUR-HSCB	MAX-HSCB				
NETA	71	0	0								

=>
 F1=HELP F3=RETURN F4=GWNAU DETAILS F6=ROLL F7=BACK F8=FORWARD F10=HEX
 ENTER=GWNAU COUNTS(POSITION CURSOR ON NETWORK) F12=REFRESH PA1=EXIT PA2=LOG

Figure 4-58. ATUNN HSCBs (Networks and HSCB Counts) Panel

Description

The ATUNN HSCBs (Networks and HSCB Counts) panel, which is available for NCP V6R1 or earlier releases, displays information on the use of half-session control blocks (HSCBs).

To display this panel:

- From the first PF key selection of the ATUNP NCP Selection panel, as shown on page 4-204, press F4.
- From the third PF key selection of the ATUCD CDS NCP Selection panel, as shown on page 4-27, press F4.
- From the first PF key selection of the ATUNW NCP Wide Selection panel, as shown on page 4-212, press F4.
- From the first PF key selection of the ATUSS Summary Status panel, as shown on page 4-260, press F4.

Two unique HSCBs are used for each cross-network SNI session, one in each network.

Fields

NCP name (second field on panel)

Name of the NCP that is currently displayed. You can enter a different NCP name in this field to display information about another NCP.

NETWORKS

Total number of SNI cross networks.

TOTAL HSCBS IN USE

Total number of HSCBs (NIX/NLX pairs) in use for all networks.

ALARM THRESHOLD

Alarm threshold for HSCB use. You can enter a value in this field to change the alarm threshold. NTuneMON issues a generic alert (if specified) when the number of HSCBs in use for a network reaches the percentage of the total number of HSCBs that can be used for that network (defined by the NETLIM keyword on the BUILD and NETWORK statements).

A shortage of HSCBs can cause session activation to fail with an insufficient resource sense code. If the total number of HSCBs in use nears the alarm threshold, increase the value of the NETLIM keyword on the BUILD or NETWORK statement. You may also need to increase the total number of HSCBs by increasing the value of the HSBPOOL keyword on the BUILD statement.

The following columns on this panel show information for each network.

NETWORK

Network name.

SUBAREA

Adjacent subarea address.

CUR-HSCB

Number of HSCBs currently in use for each network. This count is the number of cross-network SNI sessions through a gateway NCP.

MAX-HSCB

Maximum number of HSCBs that can be used for the network, as defined by the NETLIM keyword on the BUILD or NETWORK statement.

PF Keys

F1=HELP

Displays online help for this panel.

F3=RETURN

Returns to the previous NTuneMON panel.

F4=GWNAU DETAILS

Displays the ATUIB GWNAUs in Use Counts panel as shown on page 4-158, to show the GWNAUs in use for a particular network. Place the cursor under the name of the network you want to view and press F4.

Note: Performing this analysis interactively can take a long time. Instead, you may want to perform this analysis by starting NTuneMON with OUTPUT=LINE and TYPE=GWNAU. TYPE=SUMMARY does not include the GWNAU analysis.

F6=ROLL

Returns to the NetView command line without exiting NTuneMON. To return to NTuneMON from the NetView program, press F6=ROLL or enter **ATUNEMON** on the NetView command line.

F7=BACK

Scrolls the panel data backward one screen.

F8=FORWARD

Scrolls the panel data forward one screen.

F10=HEX

Displays the ATUDP Hexadecimal Storage Display panel, as shown on page 4-68, to show the network vector table (NVT).

ENTER=GWNAU COUNTS(PPOSITION CURSOR ON NETWORK)

Displays the ATUNA GWNAU Names and HSCBs panel, as shown on page 4-192, which shows the number of GWNAUs in use and the total number of GWNAUs. Place the cursor under the name of the network you want to view and press Enter.

Note: Performing this analysis interactively can take a long time. Instead, you might want to perform this analysis by starting NTuneMON with **OUTPUT=LINE** and **TYPE=GWNAU**. **TYPE=SUMMARY** does not include the GWNAU analysis.

F12=REFRESH

Refreshes the information on HSCB use from node initialization block (NIB) control block statuses.

PA1=EXIT

Exits NTuneMON.

PA2=LOG

Saves the information on this panel to the NetView log.

ATUNP NCP Selection Panel

Basic fast-path commands: NP, GEN
 Tuning fields: None

```

ATUNP                                NCP Selection Panel                                NTuneMON V2R5  14:05
NUMBER OF ACTIVE NCPS= 2
NCP  SUBAREA GEN-DATE NCP  CTLR  NCP  SUBAREA GEN-DATE NCP  CTLR
A79SUTB 79  06/09/98  V7R7F 374541A
A80SUTB 80  06/08/98  V7R7F 374541A

=>
F1=HELP 2=VRs 3=RETURN 4=SNI (HSCBs) 5=ADAPTERS 6=ROLL 7=BACK 8=FORWARD 9=NNTs
ENTER=SUMMARY 10=UTIL 11=ALT-PFKs 12=REFRESH(FIND ALL NCPS) PA1=EXIT PA2=LOG
    
```

Figure 4-59. ATUNP NCP Selection Panel

Note

Although this manual shows earlier release numbers on some panels, all actual NTuneMON V2R6 panels show the version and release as “V2R6”.

Description

The ATUNP NCP Selection panel is the main NTuneMON panel, the first panel displayed when you start NTuneMON. This panel lists the active NCPs in the native network known to the VTAM host on which NTuneMON is running unless you specify otherwise when you start NTuneMON.

Fields

NUMBER OF ACTIVE NCPS

Number of NCPs NTuneMON is monitoring. If you specified the monitoring of all NCPs when you started NTuneMON, this is the number of active NCPs known to the host on which NTuneMON is running. If you specified the monitoring of only certain NCPs, this is the number of those NCPs that are active.

The following columns on this panel show information for each NCP.

NCP

Names of active NCPs, as defined by the NEWNAME keyword on the BUILD statement.

SUBAREA

Subarea addresses (in decimal), as defined by the SUBAREA keyword on the BUILD statement.

GEN-DATE

NCP generation date, as defined by the GENLEVEL keyword on the BUILD statement. This value depends on what was coded for GENLEVEL; therefore, it might not be the actual NCP generation date (GENDATE). (If GENLEVEL was not coded, the default is the date and time the generation was run.) NTuneMON uses the value in this field to determine whether the NCP was reloaded. If you have reloaded a new NCP and GENLEVEL was specified and has not been changed, restart NTuneMON with RESET=YES to reset the global variables.

This field is color-coded as follows:

- 20th-century (19xx) dates are shown in reverse-video red.
- 21st-century (20xx) dates are shown in reverse-video green.

NCP

NCP version and release, as defined by the VERSION keyword on the BUILD statement.

CTLR

Communication controller model number, as defined by the MODEL keyword on the BUILD statement.

PF Keys**PF Key Selection Number 1**

This is the default set of PF keys for this panel.

F1=HELP

Displays online help for this panel.

F2=VRs

Displays the ATUVR Virtual Route panel, as shown on page 4-334, to show information on all active virtual routes for an NCP. Place the cursor under an NCP name and press F2.

F3=RETURN

Returns to the previous NTuneMON panel, or exits NTuneMON if you have not displayed any other NTuneMON panel.

F4=SNI(HSCBs)

Displays the ATUNG HSCBs and GWNAUs panel (for NCP V6R2 or later releases), as shown on page 4-195, or the ATUNN HSCBs (Networks and HSCB Counts) panel (for earlier NCP releases), as shown on page 4-201. These panels provide information on half-session control blocks (HSCBs) and gateway network addressable units (GWNAUs) for an NCP. Place the cursor under an NCP name and press F4.

F5=ADAPTERS

Displays the ATUSC1 Channel Adapters panel, as shown on page 4-230, which provides information on IBM 3745 channel adapters for an NCP. Place the cursor under an NCP name and press F5.

F6=ROLL

Returns to the NetView command line without exiting NTuneMON. To return to NTuneMON from the NetView program, press F6=ROLL or enter **ATUNEMON** on the NetView command line.

ATUNP NCP Selection Panel

F7=BACK

Scrolls the panel data backward one screen.

F8=FORWARD

Scrolls the panel data forward one screen.

F9=NNTs

Displays the ATUNT NCP Network Names Table panel, as shown on page 4-209, to show network names table entries and use counts for an NCP. Place the cursor under an NCP name and press F9.

ENTER=SUMMARY

Displays the ATUSS Summary Status panel, as shown on page 4-260, to show a wide variety of information for one NCP. Place the cursor under an NCP name and press Enter.

F10=UTIL

Displays the ATUUT NCP Utilization panel, as shown on page 4-328, to show information on NCP CCU and buffer use for an NCP. Place the cursor under an NCP name and press F10.

F11=ALT-PFKS

Resets some of the PF keys on this panel to perform different functions. These alternate PF keys are shown in Figure 4-60.

F12=REFRESH(FIND ALL NCPs)

Updates the list of active NCPs, depending on the FAST startup option described on page 2-17.

PA1=EXIT

Exits NTuneMON.

PA2=LOG

Saves the information on this panel to the NetView log.

PF Key Selection Number 2

Figure 4-60 shows the second set of PF keys for this panel. These alternate functions are enabled when you press F11=ALT-PFKS in the first PF key selection. The alternate functions are described following the figure.

```
=> ATUM022 PF keys have been set to selection number 2
F1=HELP 2=CBPOOLS 3=RETURN 4=CDS INFO 5=TGs 6=ROLL 7=BACK 8=FWD 9=TOKEN-RING
ENTER=SUMMARY 10=HEX 11=ALT-PFKS 12=REFRESH(FIND ALL NCPs) PA1=EXIT PA2=LOG
```

Figure 4-60. PF Key Selection Number 2 for the ATUNP NCP Selection Panel

F2=CBPOOLS

Displays the ATUCB Control Block Pools/Tables panel, as shown on page 4-17, to provide information on the use of NCP control block pools. Place the cursor under an NCP name and press F2.

F4=CDS INFO

Displays the ATUCD CDS NCP Selection panel, as shown on page 4-27, to show additional information on the maintenance of each NCP and the communication controller in which it is running.

F5=TGs

Displays the ATUTG Transmission Group panel, as shown on page 4-294, to show information on transmission groups for an NCP. Place the cursor under an NCP name and press F5.

F9=TOKEN-RING (starting with NCP V5R4)

Displays the ATUTC Token-Ring Adapter List panel, as shown on page 4-278, to show information on Token-Ring physical lines for an NCP. Place the cursor under an NCP name and press F9.

F10=HEX

Displays the ATUDP Hexadecimal Storage Display panel, as shown on page 4-68, to show the date and time generation control block (DTG). Place the cursor under an NCP name and press F10.

F11=ALT-PFKS

Resets some of the PF keys on this panel to perform different functions. These alternate PF keys are shown in Figure 4-61.

PF Key Selection Number 3

Figure 4-61 shows the third set of PF keys for this panel. These alternate functions are enabled when you press F11=ALT-PFKS in the second PF key selection. The alternate functions are described following the figure.

```
=> ATUM022 PF keys have been set to selection number 3
F1=HELP 2=ETHERNET 3=RETURN 4=WIDE BUFS/UTIL 5=FRELAY 6=ROLL 7=BACK 8=FORWARD
ENTER=SUMMARY 9=IP STATS 10=SDLC 11=ALT-PFKS 12=REFRESH PA1=EXIT PA2=LOG
```

Figure 4-61. PF Key Selection Number 3 for the ATUNP NCP Selection Panel

F2=ETHERNET (NCP V6R1 or later releases)

Displays the ATUEP Ethernet Adapter List panel, as shown on page 4-81, to show information on Ethernet-type subsystem (ESS) adapters for an NCP. Place the cursor under an NCP name and press F2.

F4=WIDE BUFS/UTIL

Displays the ATUNW NCP Wide Selection panel, as shown on page 4-212, to show information on active NCPs, including information on the maintenance level of each NCP and the communications controller in which it is running.

F5=FRELAY (NCP V6R1 or later releases)

Displays the ATUFC Physical Line List panel, as shown on page 4-94, to show information on frame-relay physical lines for an NCP. Information is provided for all frame-relay lines regardless of adapter. Place the cursor under an NCP name and press F5.

F9=IP STATS (starting with NCP V6R2)

Displays the ATUIS IP Router Statistics Page 1 panel, as shown on page 4-175, to show information on NCP Internet Protocol functions for an NCP. Place the cursor under an NCP name and press F9.

F10=SDLC

Displays the ATUFC Physical Line List panel, as shown on page 4-94, to show information on SDLC physical lines regardless of the adapter. Place the cursor under an NCP name and press F10.

F11=ALT-PFKS

Resets some of the PF keys on this panel to perform different functions. These alternate PF keys are shown in Figure 4-62 on page 4-208.

PF Key Selection Number 4

Figure 4-62 shows the fourth set of PF keys for this panel. These alternate functions are enabled when you press F11=ALT-PFKS in the third PF key selection. The alternate functions are described following the figure.

```
=> ATUM022 PF keys have been set to selection number 4  
F1=HELP 2=X25NPSI 3=RETURN 4=ISDN 6=ROLL 7=BACK 8=FORWARD  
ENTER=SUMMARY 11=ALT-PFKS 12=REFRESH PA1=EXIT PA2=LOG
```

Figure 4-62. PF Key Selection Number 4 for the ATUNP NCP Selection Panel

F2=X25NPSI

Displays the ATUXL X.25 MCH Physical Line List panel, as shown on page 4-350, to list the X.25 multichannel (MCH) physical lines. Place the cursor under an NCP name and press F2.

F4=ISDN

Displays the ATUDL ISDN Physical Line Table panel, as shown on page 4-59, to list the ISDN physical lines that are defined for the selected NCP. Place the cursor under an NCP name and press F4.

F11=ALT-PFKS

Resets the PF keys on this panel to perform their original functions, as described on page 4-205.

ATUNT NCP Network Names Table Panel

Basic fast-path commands: NT, NNT

Tuning fields: None

ATUNT A04NT02		NCP Network Names Table			NTuneMON V2R1 09:59	
(Non-Dynamic Names Use Counts)						
CUR USE=	0%	MAX USE=	0%	ALERT=	80%	
CUR USE=	1	MAX USE=	1	TOTAL=	120	DYNAMIC= 0
NETA	1					
=>						
F1=HLP F3=RTN F6=ROLL F7=BACK F8=FWD F9=CP F10=HEX F11=NETID F12=RFRSH PA2=LOG						

Figure 4-63. ATUNT NCP Network Names Table Panel

Description

The ATUNT NCP Network Names Table panel displays entries in the network names table (NNT) for a particular NCP.

The names listed on this panel may not all be in use. This panel lists all names known to NCP, except entries that were built dynamically in the NCP buffer pool, by the NCP V7R1 dynamic CB function, along with their reference counts.

To display this panel:

- From the first PF key selection of the ATUNP NCP Selection panel, as shown on page 4-204, press F9.
- From the third PF key selection of the ATUCD CDS NCP Selection panel, as shown on page 4-27, press F9.
- From the first PF key selection of the ATUNW NCP Wide Selection panel, as shown on page 4-212, press F9.
- From the first PF key selection of the ATUSS Summary Status panel, as shown on page 4-260, press F9.

When you first enter this panel, it displays both control point names (in turquoise) and network identifiers (NETIDs, in yellow). Press F9 to display only control point names, or press F11 to display only NETIDs. Figure 4-63 shows both control point names and NETIDs.

Fields

NCP name (second field on panel)

Name of the NCP that is currently displayed. You can enter a different NCP name in this field to display information on another NCP.

CUR USE (%)

Percentage of NNT entries currently in use. If the current percentage in use reaches the threshold, NTuneMON highlights the count in reverse-video red and issues a generic alert (if specified).

MAX USE (%)

Highest percentage of NNT entries in use since this NCP was loaded.

ALERT

Alert threshold for NNT entry use. You can enter a value in this field to change the alert threshold. If the CUR USE % or MAX USE % is equal to or exceeds the THRSH, NTuneMON displays the field in reverse-video red and issues a generic alert (if specified). You can also set this threshold on the ATUCB Control Block Pools/Tables panel, as shown on page 4-17.

You can increase the number of NNT entries by increasing the value of the NAMTAB keyword on the BUILD statement, or by using the NCP V7R1 dynamic CB function.

CUR USE

Number of NNT entries currently in use.

MAX USE

Highest number of NNT entries in use since this NCP was loaded.

TOTAL

Total number of NNT entries in use.

DYNAMIC (starting with NCP V7R1)

Total number of dynamic NNT entries in use. If the number is greater than zero, it is highlighted in reverse-video pink. If there are dynamic entries, you may want to increase the value of the NAMTAB keyword on the BUILD statement and regenerate the NCP.

PF Keys

F1=HLP

Displays online help for this panel.

F3=RTN

Returns to the previous NTuneMON panel.

F6=ROLL

Returns to the NetView command line without exiting NTuneMON. To return to NTuneMON from the NetView program, press F6=ROLL or enter **ATUNEMON** on the NetView command line.

F7=BACK

Scrolls the panel data backward one screen.

F8=FWD

Scrolls the panel data forward one screen.

F9=CP

Displays only control point names.

F10=HEX

Displays the ATUDP Hexadecimal Storage Display panel, as shown on page 4-68, to show the network names table (NNT).

F11=NETID

Displays only NETIDs.

F12=RFRSH

Refreshes the information on this panel.

PA1=EXIT

Exits NTuneMON.

PA2=LOG

Saves the information on this panel to the NetView log.

ATUNW NCP Wide Selection Panel

Basic fast-path command: NW
 Tuning fields: None

```

ATUNW NCPs= 1          NCP Wide Selection          NTuneMON V2R1  14:56
NCP   SUBAREA NCP-VER  CNTL  MEM  S/N   CCU  BUF  NETs  HSCBS  NNTs  LUBs  NHSAS
A04NT05   4   V7R3F  3745-41A 8MB 0003606  1%  1%   1    0   2%  3%  11%

=>
F1=HELP 2=VRs 3=RETURN 4=SNI(HSCBs) 5=ADAPTERS 6=ROLL 7=BACK 8=FORWARD 9=NNTs
ENTER=SUMMARY 10=UTILIZATION 11=ALT-PFKS 12=REFRESH PA1=EXIT PA2=LOG
    
```

Figure 4-64. ATUNW NCP Wide Selection Panel

Description

The ATUNW NCP Wide Selection panel is similar to the ATUNP NCP Selection panel, as shown on page 4-204. Both panels list the active NCPs known to the VTAM host on which NTuneMON is running, and both panels provide quick access to more information on specific NCPs. The ATUNW NCP Wide Selection panel provides additional information on the maintenance level of each NCP and the communication controller in which it is running.

Viewing the ATUNW NCP Wide Selection panel is an easy way to compare the use of specific resources by different NCPs. Also, because this panel shows the controller serial number, you can see which NCPs are running on the same controller.

To display this panel:

- From the third PF key selection of the ATUNP NCP Selection panel, as shown on page 4-204, press F4.
- From the first PF key selection of the ATUCD CDS NCP Selection panel, as shown on page 4-27, press F4.

Fields

NCPs

Number of NCPs NTuneMON is monitoring. If you specified the monitoring of all NCPs when you started NTuneMON, this is the number of active NCPs known to the host on which NTuneMON is running. If you specified the monitoring of only certain NCPs, this is the number of those NCPs that are active.

The following columns on this panel show information for each NCP.

NCP

Names of active NCPs, as defined by the NEWNAME keyword on the BUILD statement.

SUBAREA

Subarea addresses (in decimal), as defined by the SUBAREA keyword on the BUILD statement.

NCP-VER

NCP version and release, as defined by the VERSION keyword on the BUILD statement.

CNTL

Communication controller model number, as defined by the MODEL keyword on the BUILD statement.

MEM

Controller storage, as defined by the MEMSIZE keyword on the BUILD statement.

S/N

Communication controller serial number.

CCU

Controller CCU use, shown as the percentage of cycles used out of the total number available.

BUF

Percentage of NCP buffers in use. This value depends on the amount of NCP storage (the MEMSIZE keyword on the BUILD statement), the NCP load module size, and the NCP buffer size (the BFRS keyword on the BUILD statement).

NETs

Number of networks (excluding any model network). A model network is a template for a network definition. For more information, see the COPIES keyword in *NCP, SSP, and EP Resource Definition Reference*.

HSCBS

Number of half-session control blocks defined for the NCP by the HSBPOOL keyword on the BUILD statement.

NNTs

Percentage of network names table entries in use. The number of table entries as defined by the NAMTAB keyword on the BUILD statement.

LUBs

Percentage of logical unit control blocks in use for dynamically added LUs and switched LUs, based on the NUMILU, NUMTYP1, and NUMTYP2 keywords on the LUDRPOOL statement and LUs coded with LUDR=YES on the LU statement. LUs coded with LUDR=NO are considered permanently assigned; therefore they are not included in the total for LUDRPOOL.

NHSAS

Percentage of the number of subareas with virtual routes ending in this NCP that are currently in use based on the NUMHSAS keyword on the BUILD and NETWORK statements.

PF Keys

PF Key Selection Number 1

This is the default set of PF keys for this panel.

F1=HELP

Displays online help for this panel.

F2=VRs

Displays the ATUVR Virtual Route panel, as shown on page 4-334, which provides information on all active virtual routes for an NCP. Place the cursor under an NCP name and press F2.

F3=RETURN

Returns to the previous NTuneMON panel.

F4=SNI(HSCBs)

Displays the ATUNG HSCBs and GWNAUs panel (for NCP V6R2 or later releases), as shown on page 4-195, or the ATUNN HSCBs (Networks and HSCB Counts) panel as shown on page 4-201 (for earlier NCP releases). These panels provide information on half-session control blocks (HSCBs) and gateway network addressable units (GWNAUs) for an NCP. Place the cursor under an NCP name and press F4.

F5=ADAPTERS

Displays the ATUSC1 Channel Adapters panel, as shown on page 4-230, which provides information on IBM 3745 channel adapters for an NCP. Place the cursor under an NCP name and press F5.

F6=ROLL

Returns to the NetView command line without exiting NTuneMON. To return to NTuneMON from the NetView program, press F6=ROLL or enter **ATUNEMON** on the NetView command line.

F7=BACK

Scrolls the panel data backward one screen.

F8=FORWARD

Scrolls the panel data forward one screen.

F9=NNTs

Displays the ATUNT NCP Network Names Table panel, as shown on page 4-209, which displays network names table entries and use counts for an NCP. Place the cursor under an NCP name and press F9.

ENTER=SUMMARY

Displays the ATUSS Summary Status panel, as shown on page 4-260, which shows a wide variety of information for one NCP. Place the cursor under an NCP name and press the Enter key.

F10=UTILIZATION

Displays the ATUUT NCP Utilization panel, as shown on page 4-328, which provides information on NCP CCU and buffer use for an NCP. Place the cursor under an NCP name and press F10.

F11=ALT-PFKS

Resets some of the PF keys on this panel to perform different functions. These alternate PF keys are shown in Figure 4-65 on page 4-215.

F12=REFRESH

Updates the list of active NCPs, depending on the FAST startup option as described on page 2-17.

PA1=EXIT

Exits NTuneMON.

PA2=LOG

Saves the information on this panel to the NetView log.

PF Key Selection Number 2

Figure 4-65 shows the second set of PF keys for this panel. These alternate functions are enabled when you press F11=ALT-PFKS in the first PF key selection. The alternate functions are described following the figure.

```
=> ATUM022 PF keys have been set to selection number 2
F1=HELP 2=CBPOOLS 3=RETURN 4=CDS INFO 5=TGs 6=ROLL 7=BACK 8=FORWARD
ENTER=SUMMARY 9=TOKEN-RING 10=HEX 11=ALT-PFKS 12=REFRESH PA1=EXIT PA2=LOG
```

Figure 4-65. PF Key Selection Number 2 for the ATUNW NCP Wide Selection Panel

F2=CBPOOLS

Displays the ATUCB Control Block Pools/Tables panel, as shown on page 4-17. Place the cursor under an NCP name and press F2.

F4=CDS INFO

Displays the ATUCD CDS NCP Selection panel, as shown on page 4-27, which provides additional information on active NCPs.

F5=TGs

Displays the ATUTG Transmission Group panel, as shown on page 4-294, which provides information on transmission groups for an NCP. Place the cursor under an NCP name and press F5.

F9=TOKEN-RING (starting with NCP V5R4)

Displays the ATUTC Token-Ring Adapter List panel, as shown on page 4-278, which provides information on Token-Ring physical lines for an NCP. Place the cursor under an NCP name and press F9.

F10=HEX

Displays the ATUDP Hexadecimal Storage Display panel, as shown on page 4-68, which shows the date and time generation control block (DTG). Place the cursor under an NCP name and press F10.

F11=ALT-PFKS

Resets some of the PF keys on this panel to perform different functions. These alternate PF keys are shown in Figure 4-66.

PF Key Selection Number 3

Figure 4-66 shows the third set of PF keys for this panel. These alternate functions are enabled when you press F11=ALT-PFKS in the second PF key selection. The alternate functions are described following the figure.

```
=> ATUM022 PF keys have been set to selection number 3
F1=HELP 2=ETHERNET 3=RETURN 4=SDLC 5=FRAME RELAY 6=ROLL 7=BACK 8=FORWARD
9=IP STATS ENTER=SUMMARY 10=CSS 11=ALT-PFKS 12=REFRESH PA1=EXIT PA2=LOG
```

Figure 4-66. PF Key Selection Number 3 for the ATUNW NCP Wide Selection Panel

ATUNW NCP Wide Selection Panel

F2=ETHERNET (NCP V6R1 or later releases)

Displays the ATUEP Ethernet Adapter List panel, as shown on page 4-81, which provides information on Ethernet-type subsystem (ESS) adapters for an NCP. Place the cursor under an NCP name and press F2.

F4=SDLC

Displays the ATUFC Physical Line List panel, as shown on page 4-94, which shows a list of all SDLC lines defined to this NCP. Place the cursor under an NCP name and press F4.

F5=FRAME RELAY (NCP V6R1 or later releases)

Displays the ATUFC Physical Line List panel, as shown on page 4-94, which provides information on frame-relay physical lines for an NCP. Place the cursor under an NCP name and press F5.

F9=IP STATS (NCP V6R1 or later releases)

Displays the ATUIS IP Router Statistics Page 1 panel, as shown on page 4-175, to show information on NCP Internet Protocol functions for an NCP. Place the cursor under an NCP name and press F9.

F10=CSS (starting with NCP V6R2)

Displays the ATUSC4 3746 Model 900 Adapters panel, as shown on page 4-237, which provides information on 3746 Model 900 connectivity subsystem (CSS) adapters for an NCP. Place the cursor under an NCP name and press F10.

F11=ALT-PFKS

Resets some of the PF keys on this panel to perform different functions. These alternate PF keys are shown in Figure 4-67.

PF Key Selection Number 4

Figure 4-67 shows the fourth set of PF keys for this panel. These alternate functions are enabled when you press F11=ALT-PFKS in the third PF key selection. The alternate functions are described following the figure.

```
=> ATUM022 PF keys have been set to selection number 4
F1=HELP 2=X25NPSI 3=RETURN 4=ISDN 6=ROLL 7=BACK 8=FORWARD
ENTER=SUMMARY 11=ALT-PFKS 12=REFRESH PA1=EXIT PA2=LOG
```

Figure 4-67. PF Key Selection Number 4 for the ATUNW NCP Wide Selection Panel

F2=X25NPSI

Displays the ATUXL X.25 MCH Physical Line List panel, as shown on page 4-350, to list the X.25 multichannel (MCH) physical lines.

F4=ISDN

Displays the ATUDL ISDN Physical Line Table panel, as shown on page 4-59, to list the ISDN physical lines that are defined for the selected NCP. Place the cursor under an NCP name and press F4.

F11=ALT-PFKS

Resets the PF keys on this panel to perform their original functions, as described on page 4-214.

ATUPL SDLC Physical Line Details Panel

Basic fast-path commands: See "The PL Fast-Path Command."

Tuning fields: Line Speed, HISPEED, LSPRI, CLOCKNG, PAUSE, NRZI, SERVLIM

```

ATUPL  A7ISUP1          SDLC Physical Line Details          NTuneMON V2R4  15:47
CCU =    0%                Elapsed Time = 0

| Line Addr = ( 1 , HALF )      LEASED
| Line Name = A71LN01          Element Addr = 968
| Line Speed= 2400             PAUSE = ( 0.2 , 2.8 )
| Line Type = TSS             HISPEED = NO                DUPLEX = FULL
| Status   = INACTIVE          NRZI = YES
| LSPRI   = PU                 SERVLIM =( 4 , 0.0 )
| CLOCKNG = EXT

| LPDA Status                   POLLING
| LPDA Not Supported            Negative Polls = 0
| Tailed = N/A                 Positive Polls = 0
|                               Total Polls  = 0

| Last PSA Error Status
| 00000000 00000000 00000000 00000000

=> ATUM017 Press F12 to see Traffic or Polling rates
F1=HELP  F3=RETURN          F5=MODIFY  F6=ROLL  F10=HEX
ENTER=STATIONS(PUS)  F12=REFRESH,POLLING RATES  PA1=EXIT  PA2=LOG
    
```

Figure 4-68. ATUPL SDLC Physical Line Details Panel

Description

The ATUPL SDLC Physical Line Details panel displays detailed information for a SDLC physical line (TSS, HPTSS, or CLP) selected from the ATUFC Physical Line List panel.

To display this panel:

- On the ATUFC Physical Line List panel, as shown on page 4-94, place the cursor under an SDLC line and press Enter.
- From the ATUSP1 SDLC Peripheral Line Parameters Page 1 panel, as shown on page 4-249, or from the ATUSP2 SDLC Peripheral Line Parameters Page 2 panel, as shown on page 4-255, press F11.

The PL Fast-Path Command

To access the ATUPL SDLC Physical Line Details panel from any NTuneMON panel (except help panels), use the PL fast-path command. The following diagram shows the syntax of the PL fast-path command and its operands. The *ncpname* operand is optional, but if it is specified it must precede the *address* operand. The *address* operand is required.

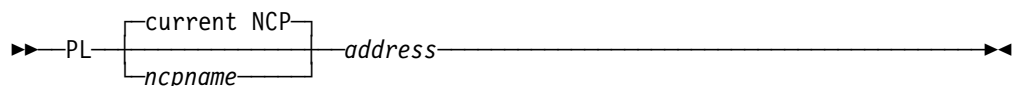

ncpname The name of the NCP as defined in the NCP gen. If this operand is omitted, NTuneMON uses the NCP name that is displayed on the top of the panel where the PL command is entered.

ATUPL SDLC Physical Line Details Panel

address The address of the SDLC link as defined by the ADDRESS keyword on the LINE definition statement.

Fields

NCP name (second field on panel)

Name of the NCP that is currently displayed.

SDLC Physical Line Details

CCU

Percentage of controller CCU cycles in use.

Elapsed Time

Amount of time that has passed from panel entry until the panel is refreshed or the amount of time that has passed since statistics were last refreshed.

Line Addr

Address of this line, as defined by the ADDRESS keyword on the LINE statement. The address is followed by FULL if the line is full-duplex, or HALF if the line is half-duplex.

Line Name

Name of this line. This name is the label on the LINE statement. For NCP V4R1 and NCP V4R2, this field will be blank.

Line Speed

Data rate for the line in bits per second, as defined by the *rate* suboperand of the SPEED keyword on the LINE definition statement. This is the rate at which the devices communicate with the communication controller.

NCP V7R6 and Earlier Releases: The SPEED value displayed on this panel might differ from the rate specified for the SPEED keyword:

- For TSS and HPTSS adapters with CLOCKNG=EXT, following are the displayed values for SPEED. These values are valid only for NCP V5R4 and later, running on a 3745.

50, 75, 100, 110, 134, 200, 300, 600, 1200, 2400, 4800, 9600, 19200, 38400, 55855, 245760, 1843200

If a value in the above list was specified for SPEED, the panel displays that value. If an unlisted value less than 1843200 was specified for SPEED, the panel displays the next highest listed value. For example, if 60 was specified, the panel displays 75. If a value greater than 1843200 was specified for SPEED, the panel displays 1843200.

Note: For NCP V4R3.1 and earlier, the speed is displayed as "N/A".

- For 3746 Model 900 lines with CLOCKNG=INT or CLOCKNG=DIRECT, see Table 6-8 on page 6-104 to find the displayed speed.
- For 3746 Model 900 lines with CLOCKNG=EXT, the value displayed for SPEED represents a range of speeds as shown in Table 4-2 on page 4-219.

Table 4-2. SPEED Values for IBM 3746 Model 900 SDLC Lines When CLOCKNG=EXT and VERSION<V7R7

Displayed SPEED Value	Actual Data Rate (SPEED) Values for CLOCKNG=EXT
19200	>= 600 and <= 32000
38400	> 32000 and <= 64000
256000	> 64000 and <= 256000
512000	> 256000

Line Type

Line adapter type: TSS (low speed), HPTSS (high speed) or CLP (for the 3746 Model 900).

HISPEED (SDLC TSS only)

Whether the line operates at speeds of 144 Kbps or greater, as defined by the HISPEED keyword on the LINE statement.

Status

Status of the line. The status can be any of the following:

- PEND ACTLINK** An activate link command (ACTLINK) is in progress.
- ACTIVE** An ACTLINK has been processed, and the line is active.
- PEND DACTLNK** A deactivate link command (DACTLINK) is in progress.
- INACTIVE** A DACTLINK has been processed, and the line is inactive. Inactive lines are highlighted in reverse-video red.
- FORCE DEACT** The line has been forced into deactivation. (A force deactivate command was issued from VTAM.)
- PEND ANS** Line quiescence is pending due to automatic network shutdown (ANS).
- PEND SWITCH** A switch from primary to secondary is in progress.
- OLT TESTING** Online line testing (OLT) is in progress.
- WRAP TESTING** Wrap testing is in progress.

LSPRI

Whether transmission priority is to be used to determine the order in which PIUs are transmitted to the PU as defined by the LSPRI keyword on the LINE statement.

CLOCKNG

Whether the modem (data set) or the communication scanner for the line provides the clocking, as defined by CLOCKNG keyword on the LINE statement.

DIRECT

The scanner provides clocking and propagates it to the attached DTE. The data signal received by the controller is synchronized with the controller's clock. You must use a directly attached cable.

EXT

The modem or other external source provides clocking. You can use either a directly attached cable or a modem cable.

INT

The scanner provides clocking but does not propagate it to the attached data terminal equipment (DTE). The scanner synchronizes the received data signal; a different clock is used at each end of a link. You can use either a directly attached cable (no modem) or a modem cable.

SWITCHED/LEASED

Whether the line is switched (DIAL=YES) or leased (DIAL=NO), as defined by the DIAL keyword on the GROUP statement.

Element Addr

The element address of the line.

PAUSE

The delay in seconds between successive polling cycles, as defined by the PAUSE keyword on the LINE statement.

PAUSE(t1)

Specifies the pause for this line if the line is operating as a modulo-8 line, as defined by the *t1* suboperand of the PAUSE keyword on the LINE statement.

PAUSE(t2)

Specifies the pause for this line if the line is operating as a modulo-128 line, as defined by the *t2* suboperand of the PAUSE keyword on the LINE statement.

DUPLEX

HALF or FULL to indicate whether the communication line and modem constitute a half-duplex or a duplex facility, as defined by the DUPLEX keyword on the LINE statement.

Duplex is applicable only when Line Addr=(n, HALF). DUPLEX=HALF means the request-to-send (RTS) signal is active only when NCP is sending data. DUPLEX=FULL means the RTS signal is active when NCP is sending or receiving data.

Note: Do not confuse this with half-duplex or duplex data transfer. DUPLEX specifies only the physical characteristic of the communication facility, and is used to control the request-to-send (RTS) signal.

NRZI

YES or NO to specify whether the data terminal equipment at the end of the SDLC link must operate in non-return-to zero change-on-ones mode (YES) or in non-return-to-zero mode (NO). Defined by the NRZI keyword on the LINE statement.

SERVLIM

SERVLIM is used by the primary line to control the polling of secondary stations.

Scan Limit (starting with NCP V4R3.1)

The first value after SERVLIM= is the SERVLIM scan limit. This is the maximum number of regular scans of the service order table (SOT) that NCP is to make for normal servicing of PUs and LUs on the link before it makes a special scan of the SOT. The SERVLIM scan limit is defined by the *entries* suboperand of the SERVLIM keyword on the LINE or SDLCST statement.

Timer (starting with NCP V7R4)

The second value after SERVLIM= is the SERVLIM timer value. This specifies the maximum time, in seconds, that NCP spends making regular scans of the SOT before making a special scan of the SOT. The SERVLIM timer value is defined by the *seconds* suboperand of the SERVLIM keyword on the LINE or SDLCST statement.

Link Problem Determination Aid (LPDA) Status

LPDA support indicator

Displays the LPDA mode specified by the LPDATS keyword on the LINE statement. Possible modes are:

- LPDA1 Supported
- LPDA2 Supported
- LPDA Not Supported

Tailed

YES or NO to indicate whether the physical line is tailed. If LPDA is not supported, N/A is displayed in this field.

POLLING

This section of the panel displays statistics for negative, positive, and total polls. This panel displays polls as numbers until F12 is pressed; then it displays polls per second (*n/Sec*). However, any polls that are less than one per second are displayed as numbers (*n*).

Negative polls or Neg polls/Sec

NCP sent out a signal and either did not get a response or received a request for retransmission of the last data sent. This indicates that either the station is not available to respond or an error occurred.

Positive polls or Pos polls/Sec

NCP sent out a signal and got data.

Total polls or Total polls/Sec

Sum of positive and negative polls.

Notes:

1. **3746 Model 900 (all NCP releases):** A dash (–) is displayed in these fields instead of poll counts.
2. **NCP V7R2 or later releases (except 3746 Model 900):** When the line is inactive, a zero (0) is displayed in these fields because no polling is taking place.
3. **NCP V7R1 or earlier releases (except 3746 Model 900):** A dash (–) is displayed in these field instead of poll counts.
4. If polling data is not currently being collected and if you have NTuneNCP included in your NCP, you can use the ATUST NCP Function Activation panel to activate polling data collection (NTUNECOL). Type POLL on the command line and press Enter to fast-path to the ATUST NCP Function Activation panel as shown on page 4-269.

Last PSA Error Status

The last four abnormal trace entries in the Parameter Status Area (PSA) are displayed, in chronological order.

PF Keys

F1=HELP

Displays online help for this panel.

F3=RETURN

Returns to the previous NTuneMON panel.

F4=SDLC PN PARMS

Displays the ATUSP1 SDLC Peripheral Line Parameters Page 1 panel, as shown on page 4-249, to show configuration parameters for the line.

F5=MODIFY

Available when the operator has tuning authority and NTuneNCP is included. For more information, refer to Chapter 5, Using the NTuneNCP Tuning Feature.

Updates the NCP tuning parameter with the modified value. If the modification is not valid, the field turns reverse-video pink, and you are prompted to correct the value and resubmit it.

F6=ROLL

Returns to the NetView command line without exiting NTuneMON. To return to NTuneMON from the NetView program, press F6=ROLL or enter **ATUNEMON** on the NetView command line.

F10=HEX

Displays the ATUDP Hexadecimal Storage Display panel, as shown on page 4-68, to show the line control block (LKB) for this line.

ENTER=STATIONS(PUs)

Displays the ATUSL SDLC Stations List panel, as shown on page 4-246, to show the stations associated with the physical line.

F12=REFRESH/POLLING RATES

Refreshes the information on this panel to display polls per second instead of the number of polls since the last time the poll counter field wrapped.

PA1=EXIT

Exits NTuneMON.

PA2=LOG

Saves the information on this panel to the NetView log.

ATUPS Bisync/SS Line Details Panel

Basic fast-path commands: None

Tuning fields: None

```

ATUPS  PEPBG      Bisync/SS Line Details      NTuneMON V2R6  10:02
Resource Type is Bisync Line

Line Addr  =(  0 , Half )  MultiPoint      Leased
Line Speed = 50          NewSync      = NO          Call in  = -
Line Type  = TSS        CLOCKNG     = EXT        Call Out = -
Status     = Active     DUPLEX      = Half       Tele Conn = -
Control T0 = 3.0        Cutoff      = 1         Sw Mode  = -
Receive T0 = 23.5      Neg Poll    = 2         Dial Opt. = -
Transmit T0 = NONE     Wack LMT   = 15
Response T0 = 2.2      TTD Limit  = 15
Retries    = 7,4,5     Pause      = 1
Max Sess   = 4         SerLim     = 10
Terminal Type = Unknown

=>
F1=HELP  F3=RETURN  F6=ROLL  F10=HEX  F12=REFRESH  PA1=EXIT  PA2=LOG
ENTER = TERMINAL LIST.

```

Figure 4-69. ATUPS Bisync/SS Line Details Panel

Description

The ATUPS Bisync/SS Line Details panel, available beginning with NCP V7R8, displays information about a bisync or start-stop line.

To display this panel: On the ATUFC Physical Line List panel, as shown on page 4-94, place the cursor under a bisync or start-stop line and press Enter.

Fields

NCP name (second field on panel)

Name of the NCP that is currently displayed.

Resource Type is

Whether the line is a bisync line or a start-stop line.

Line Addr

Address of this line, as defined by the ADDRESS keyword on the LINE statement. The address is followed by:

Full or Half

Whether the line is full-duplex or half-duplex.

Point-to-point or MultiPoint

Whether the line connects the NCP to one station or to more than one station.

Leased or Switched

Whether the line connection is made by dialing (switched) or not (leased).

Line Speed

Data rate for the line in bits per second as defined by the *rate* suboperand of the SPEED keyword on the LINE statement. This is the rate at which the devices communicate with the communication controller.

Line Type

Line adapter type: TSS (low speed).

Status

Physical line status: Active or Inactive.

Control TO

Control timeout for the lines in the line group. Defined by the REPLYTO keyword on the GROUP statement.

Receive TO

Receive timeout for the lines in the line group. Defined by the TEXTTO keyword on the GROUP statement.

Transmit TO

Transmit timeout for the lines in the line group.

Response TO

Response timeout for the lines in the line group. For BSC lines, defined by the WAKDLAY keyword on the GROUP statement.

Retries(m, t, n)

Number of attempts to be made to recover from errors occurring during transmission over the link. Defined by the RETRIES keyword on the LINE statement. Each attempt at recovery, or *retry*, is a retransmission of data or control commands. NCP performs retries until the transmission is successful or the number of retries reaches the maximum specified by this keyword.

Retries are performed in sets, which are called *retry sequences*. NCP can perform one or more retry sequences. Successive retry sequences are separated by pauses.

Retries(m)

Maximum number of retries in each retry sequence as defined by the *m* suboperand of the RETRIES keyword on the LINE statement.

Retries(t)

Pause interval, in seconds, between successive retry sequences as defined by the *t* suboperand of the RETRIES keyword on the LINE statement.

Retries(n)

Maximum number of retry sequences as defined by the *n* suboperand of the RETRIES keyword on the LINE statement.

Max Sess

The number of sessions that NCP will attempt to maintain concurrently on a nonswitched line in network control mode. Max Sess is defined by the SESSION keyword on the LINE statement.

Terminal Type

The type of device NCP or EP will communicate with over this line, as defined by the TERM keyword on the LINE statement.

NewSync

Whether the communication controller supplies the new-sync signal to the modem (data set) on this line, as defined by the NEWSYNC keyword on the LINE statement.

CLOCKNG

Whether the modem (data set) or the communication scanner for the line provides the clocking, as defined by the CLOCKNG keyword on the LINE statement. Possible CLOCKNG values on this panel are:

DIR

The scanner provides clocking and propagates it to the attached DTE. The data signal received by the controller is synchronized with the controller's clock. You must use a directly attached cable.

External

The modem or other external source provides clocking. You can use either a directly attached cable or a modem cable.

Internal

An internal source provides clocking.

DUPLEX

Whether the communication line and modem constitute a half-duplex or a duplex facility, as defined by the DUPLEX keyword on the LINE statement.

Cutoff

Maximum number of subblocks accepted from a device. Defined by the CUTOFF keyword on the LINE statement.

Neg Poll

Negative poll pause. The amount of time NCP pauses before resuming polling after receiving a negative response to polling from a multipoint bisync station. Defined by the NEGPOLP keyword on the LINE statement.

Wack LMT

Number of times NCP accepts wait-before-transmit positive acknowledgment (WACK) from a bisync station before aborting the operation. Defined by the WACKCNT keyword on the GROUP statement.

TTD Limit

Number of times NCP accepts the bisync temporary text delay (TTD) sequence from a device before aborting the operation. Defined by the TTDCNT keyword on the GROUP statement.

Pause

The delay in seconds between successive polling cycles, as defined by the PAUSE keyword on the LINE statement.

SerLim

The maximum number of entries in the service order table (SOT) that NCP is to check for this line each time the program performs service seeking. Defined by the SERVLIM keyword on the LINE statement.

Call in

Whether the line is used for incoming calls (stations call the controller). Defined by specifying CALL=IN or CALL=INOUT on the LINE statement.

ATUPS Bisync/SS Line Details Panel

Call Out

Whether the line is used for outgoing calls (the controller calls stations).
Defined by specifying CALL=OUT or CALL=INOUT on the LINE statement.

Tele Conn

Whether there is currently a telephone connection.

Sw Mode

Current status of a switched line: NORMAL or BACKUP.

Dial Opt

The technique (MANUAL or AUTO) by which switched connections are made.
Defined by the AUTO keyword on the LINE statement.

PF Keys

F1=HELP

Displays online help for this panel.

F3=RETURN

Returns to the previous NTuneMON panel.

F6=ROLL

Returns to the NetView command line without exiting NTuneMON. To return to NTuneMON from the NetView program, press F6=ROLL or enter **ATUNEMON** on the NetView command line.

F10=HEX

Displays the ATUDP Hexadecimal Storage Display panel, as shown on page 4-68, to show the LCB control block.

F12=REFRESH

Refreshes the information on this panel. If the NCP was reloaded, the traffic rate information is not accurate until you press F12 again.

PA1=EXIT

Exits NTuneMON.

PA2=LOG

Saves the information on this panel to the NetView log.

ENTER=TERMINAL LIST (applies only to multipoint lines)

Displays the ATUPT Bisync/Start Stop Device List panel, as shown on page 4-227, to show information about attached devices.

ATUPT Bisync/Start Stop Device List Panel

Basic fast-path commands: None

Tuning fields: None

```

ATUPT A71V7R8 Bisync/Start Stop Device List NTuneMON V2R6 13:15
Line Address = 4 Link Status = Active Device Protocol = BSC
Number of Devices Found = 4

```

Dev Typ	Dev Status	Address	Xmit count
32XX	Disconnect	40407F	0
327X,328X	Disconnect	404040	0
327X,328X	Disconnect	4040C1	0
327X,328X	Disconnect	4040C2	0

```

=>
F1=HELP F3=RETURN F6=ROLL F7=BACK F8=FORWARD
F10=HEX F12=RFRSH PA1=EXIT PA2=LOG

```

Figure 4-70. ATUPT Bisync/Start Stop Device List Panel

Description

The ATUPT Bisync/Start Stop Device List panel, available beginning with NCP V7R8, displays information about attached bisync or start-stop devices.

To display this panel: On the ATUPS Bisync/SS Line Details panel, as shown on page 4-223, press the Enter key.

Fields

Line Address

Address of this line as defined by the ADDRESS keyword on the LINE statement.

Link Status

Physical line status: Active or Inactive.

Device Protocol

Type of line protocol being used, as defined by the LNCTL keyword on the GROUP statement. Valid values are *BSC* or *SS*.

Number of Devices Found

The number of devices that were found attached to the line that was being displayed when you pressed the Enter key on the ATUPS Bisync/SS Line Details panel.

Dev Typ

Device type.

ATUPT Bisync/Start Stop Device List Panel

Dev Status

Status of the device. One of the following:

Disconnect

NCP has received a DISCONNECT TP command. An INVITE or CONTACT session-initiating TP command may now be received.

Contact Pending

NCP has received a CONTACT TP command and is addressing the device.

In Session

The device has positively responded to polling or addressing.

Active

NCP has received an ACTIVATE DEVICE TP command for this device. Other TP commands can now be received.

Service Seek

NCP includes this device in the service seeking process.

Device Abnormal

NCP has received a DEACTIVATE DEVICE or RESET TP command for this device.

Connected

The device has responded positively to polling or addressing.

Invite Pending

NCP has received an INVITE PERPETUAL TP command for this device.

No Status

No status information is available for this device.

Address

Address of the port. Defined by the ADDRESS keyword on the LINE statement.

Xmit count

The number of outbound PIUs that have been transmitted.

PF Keys

F1=HELP

Displays online help for this panel.

F3=RETURN

Returns to the previous NTuneMON panel.

F6=ROLL

Returns to the NetView command line without exiting NTuneMON. To return to NTuneMON from the NetView program, press F6=ROLL or enter **ATUNEMON** on the NetView command line.

F7=BACK

Scrolls the panel data backward one screen.

F8=FORWARD

Scrolls the panel data forward one screen.

| **F10=HEX**

| Displays the ATUDP Hexadecimal Storage Display panel, as shown on page
| 4-68, to show the DVB or LCB control block, depending on what is available.

| **F12=REFRESH**

| Refreshes the information on this panel. If the NCP was reloaded, the traffic
| rate information is not accurate until you press F12 again.

| **PA1=EXIT**

| Exits NTuneMON.

| **PA2=LOG**

| Saves the information on this panel to the NetView log.

ATUSC1 Channel Adapters Panel

Basic fast-path commands: ADAPTER, ADAPTERS, SC, SC1, SCANNER, SCANNERS

Tuning fields: None

ATUSC1 A04NT02		Channel Adapters							NTuneMON V2R1 10:01	
NCP Address	0	1	2	3	4	5	6	7		
Adapter	5A	5B	7	8	13	14	15	16		
Type	CADS	-	CADS	-	-	-	-	-		
Installed	Y	-	Y	-	-	-	-	-		
Operational	OPER	-	OPER	-	-	-	-	-		
Attached	-	-	-	-	-	-	-	-		
Switched	-	-	-	-	-	-	-	-		
CA PGM	-	-	-	-	-	-	-	-		
TPS	TPS	-	-	-	-	-	-	-		
NCP Address	8	9	10	11	12	13	14	15		
Adapter	1A	1B	3	4	9	10	11	12		
Type	CADS	-	CADS	-	-	-	-	-		
Installed	Y	-	Y	-	-	-	-	-		
Operational	OPER	-	OPER	-	-	-	-	-		
Attached	Y	Y	Y	Y	Y	Y	Y	Y		
Switched	-	-	-	-	-	-	-	-		
CA PGM	NCP	-	NCP	-	-	-	-	-		
TPS	TPS	-	-	-	-	-	-	-		
=>										
F1=HELP F2=ETHERNET F3=RETURN F5=CSS F6=ROLL F8=LINE ADAPTERS F9=TOKEN-RING										
ENTER=CHANNEL DETAILS F10=HEX F12=REFRESH PA1=EXIT PA2=LOG										

Figure 4-71. ATUSC1 Channel Adapters Panel

Description

The ATUSC1 Channel Adapters panel, which is available for 3745 Communication Controllers, displays information on the configuration and status of NCP channel adapters¹. This information might be more current than the information provided by MOSS configuration panels.

For channel adapter problems, verify that the channel to NCP is active.

To display this panel:

- From the first PF key selection of the ATUNP NCP Selection panel, as shown on page 4-204, press F5.
- From the third PF key selection of the ATUCD CDS NCP Selection panel, as shown on page 4-27, press F5.
- From the first PF key selection of the ATUNW NCP Wide Selection panel, as shown on page 4-212, press F5.
- From the first PF key selection of the ATUSS Summary Status panel, as shown on page 4-260, press F5.
- From the ATUSC2 Line Adapters Page 1 panel, as shown on page 4-233, press F7.

¹ This panel does not include information for 3746 Model 900 adapters; for information on 3746 Model 900 adapters, see Figure 4-74 on page 4-237.

Fields

NCP name (second field on panel)

Name of the NCP that is currently displayed. You can enter a different NCP name in this field to display information on another NCP.

The following rows display information on each adapter position.

NCP Address

Channel adapter logical address, which can be used as the value for the ADDRESS keyword on the LINE statement.

Adapter

Channel adapter physical position, which can be used as the value for the ADDRESS keyword on the LINE statement.

Type

Channel adapter type:

CADS Channel adapter in data-streaming mode (type 6)

BCCA Buffer-chaining channel adapter (type 7)

Installed

Y indicates that a channel adapter is installed at this address. A dash (–) indicates that no channel adapter is installed.

Operational

OPER indicates that the channel adapter is operational. A dash (–) indicates that the channel adapter is not operational.

Attached

Y indicates that a channel adapter is attached to this CCU. A dash (–) indicates that no channel adapter is attached.

Switched

Y indicates that a channel adapter is switched to this CCU. A dash (–) indicates that no channel adapter is switched to this CCU.

CA PGM

Channel adapter program (NCP, EP, PEP, or NEO (NSI)).

Instead of these values, NTuneMON may display MAINT to indicate that channel adapter installation is in progress, or DOWN to indicate that the channel adapter is inoperative due to an NCP command.

EP channels are not available for analysis.

TPS

Two-processor switch: the channel adapter has two processors, A and B. A and B will appear in the Adapter fields in the columns for an even-odd pair of logical addresses.

PF Keys

F1=HELP

Displays online help for this panel.

F2=ETHERNET (NCP V6R1 or later releases)

Displays the ATUEP Ethernet Adapter List panel, as shown on page 4-81, to show configuration and traffic information on up to 16 lines.

ATUSC1 Channel Adapters Panel

F3=RETURN

Returns to the previous NTuneMON panel.

F5=CSS (if Model 900 feature is coded in NCP generation)

Displays the ATUSC4 3746 Model 900 Adapters panel, as shown on page 4-237, to show information on the communication adapters attached to the 3746 Model 900 CSS adapter for this NCP.

F6=ROLL

Returns to the NetView command line without exiting NTuneMON. To return to NTuneMON from the NetView program, press F6=ROLL or enter **ATUNEMON** on the NetView command line.

F8=LINE ADAPTERS

Displays the ATUSC2 Line Adapters Page 1 panel, as shown on page 4-233, to show information about the configuration and status of NCP line adapters.

F9=TOKEN-RING (starting with NCP V5R4)

Displays the ATUTC Token-Ring Adapter List panel, as shown on page 4-278, to show information on the Token-Ring physical lines attached to an NCP and the associated Token-Ring interface couplers (TICs) and logical lines.

ENTER=CHANNEL DETAILS

Displays the ATUCH Channel Adapter Details panel, as shown on page 4-32, to show information on CADS and BCCA channel adapters. Tab to the adapter address of an attached adapter and press Enter.

F10=HEX

Displays the ATUDP Hexadecimal Storage Display panel, as shown on page 4-68, to show the adapter information table (AIT).

F12=REFRESH

Refreshes the information on this panel.

PA1=EXIT

Exits NTuneMON.

PA2=LOG

Saves the information on this panel to the NetView log.

ATUSC2 and ATUSC3 Line Adapters Panels

Basic fast-path command: SC2 (for ATUSC2), SC3 (for ATUSC3)

Tuning fields: None

ATUSC2 A04NT02		Line Adapters Page 1								NTuneMON V2R1 10:05	
Usage Tier= 5											
<u>Adapter</u>	1	2	3	4	9	10	11	12			
Type	TRA	-	HPTSS	TSS	-	-	-	-			
Installed	Y	-	Y	Y	-	-	-	-			
Operational	OPER	-	OPER	OPER	-	-	-	-			
Attached	Y	Y	Y	Y	Y	Y	Y	Y			
Switched	-	-	-	-	-	-	-	-			
First Line	1088	-	1028	0	-	-	-	-			
Last Line	1089	-	1029	31	-	-	-	-			
<u>Adapter</u>	17	18	19	20	25	26	27	28			
Type	-	-	-	-	-	-	-	-			
Installed	-	-	-	-	-	-	-	-			
Operational	-	-	-	-	-	-	-	-			
Attached	Y	Y	Y	Y	Y	Y	Y	Y			
Switched	-	-	-	-	-	-	-	-			
First Line	-	-	-	-	-	-	-	-			
Last Line	-	-	-	-	-	-	-	-			
=>											
F1=HELP F2=ETHERNET F3=RETURN F5=CSS 6=ROLL 7=CHANNELs 8=FORWARD 9=TOKEN-RING											
ENTER=PHYSICAL LINE LIST 10=HEX 12=REFRESH PA1=EXIT PA2=LOG											

Figure 4-72. ATUSC2 Line Adapters Page 1 Panel

ATUSC3 A04NT02		Line Adapters Page 2								NTuneMON V2R1 10:06	
Usage Tier= 5											
<u>Adapter</u>	5	6	7	8	13	14	15	16			
Type	TRA	-	HPTSS	TSS	-	-	-	-			
Installed	Y	-	Y	Y	-	-	-	-			
Operational	OPER	-	OPER	OPER	-	-	-	-			
Attached	-	-	-	-	-	-	-	-			
Switched	-	-	-	-	-	-	-	-			
First Line	1092	-	1036	32	-	-	-	-			
Last Line	1093	-	1037	63	-	-	-	-			
<u>Adapter</u>	21	22	23	24	29	30	31	32			
Type	-	-	-	-	-	-	-	-			
Installed	-	-	-	-	-	-	-	-			
Operational	-	-	-	-	-	-	-	-			
Attached	-	-	-	-	-	-	-	-			
Switched	-	-	-	-	-	-	-	-			
First Line	-	-	-	-	-	-	-	-			
Last Line	-	-	-	-	-	-	-	-			
=>											
F1=HELP F2=ETHERNET F3=RETURN F5=CSS F6=ROLL F7=BACK F9=TOKEN-RING											
ENTER=PHYSICAL LINE LIST 10=HEX 12=REFRESH PA1=EXIT PA2=LOG											

Figure 4-73. ATUSC3 Line Adapters Page 2 Panel

Description

The ATUSC2 Line Adapters Page 1 panel and the ATUSC3 Line Adapters Page 2 panel display information about the configuration and status of NCP line adapters, according to CCUA and CCUB architecture. This information might be more current than information provided by MOSS configuration panels.

For line adapter problems, verify that the adapter is installed, attached, and operative.

To display the ATUSC2 Line Adapters Page 1 panel:

- From the ATUSC1 Channel Adapters panel, as shown on page 4-230, press F8.
- From the ATUSC3 Line Adapters Page 2 panel, as shown on page 4-233, press F7.

To display the ATUSC3 Line Adapters Page 2 panel:

- From the ATUSC2 Line Adapters Page 1 panel, as shown on page 4-233, press F8.
- From the ATUSC4 3746 Model 900 Adapters panel, as shown on page 4-237, press F7.

Note: These panels do not include information for 3746 Model 900 adapters. For information on 3746 Model 900 adapters, refer to the ATUSC4 3746 Model 900 Adapters panel as shown on page 4-237.

Fields

NCP name (second field on panel)

Name of the NCP that is currently displayed. You can enter a different NCP name in this field to display information on another NCP.

Usage Tier

Usage tier, as defined by the USGTIER keyword on the BUILD statement.

The following rows display information on each adapter position.

Adapter

Controller adapter position, which can be used as the value for the ADDRESS keyword on the LINE statement.

Type

Line adapter type:

TRA	Token-Ring adapter
HPTSS	High-performance transmission subsystem (high-speed scanner)
TSS	Transmission subsystem (low-speed scanner)
ALC	Airline line control adapter
ETHER	Ethernet-type subsystem (ESS) adapter

Installed

Y indicates that a line adapter is installed at this position. A dash (–) indicates that no line adapter is installed.

Operational

OPER indicates that the line adapter is operational. A dash (–) indicates that the line adapter is not operational.

Attached

Y indicates that a line adapter is attached to this CCU. A dash (–) indicates that no line adapter is attached.

Switched

Y indicates that a line adapter is switched to this CCU. A dash (–) indicates that no line adapter is switched to this CCU.

First Line

Lowest address in the range for this adapter (only if the adapter is installed).

Last Line

Highest address in the range for this adapter (only if the adapter is installed).

PF Keys

F1=HELP

Displays online help for this panel.

F2=ETHERNET (NCP V6R1 or later releases)

Displays the ATUEP Ethernet Adapter List panel, as shown on page 4-81, to show configuration and traffic information on up to 16 lines.

F3=RETURN

Returns to the previous NTuneMON panel.

F5=CSS (if Model 900 feature is coded in NCP generation)

Displays the ATUSC4 3746 Model 900 Adapters panel, as shown on page 4-237, to show information on the communication adapters attached to the 3746 Model 900 CSS adapter for this NCP.

F6=ROLL

Returns to the NetView command line without exiting NTuneMON. To return to NTuneMON from the NetView program, press F6=ROLL or enter **ATUNEMON** on the NetView command line.

F7=CHANNELs (ATUSC2 PF key)

Displays the ATUSC1 Channel Adapters panel, as shown on page 4-230, to show information on the configuration and status of NCP channel adapters.

F7=BACK (ATUSC3 PF key)

Scrolls back to the ATUSC2 Line Adapters Page 1 panel as shown on page 4-233.

F8=FORWARD (ATUSC2 PF key)

Scrolls forward to the ATUSC3 Line Adapters Page 2 panel as shown on page 4-233.

F9=TOKEN-RING (starting with NCP V5R4)

Displays the ATUTC Token-Ring Adapter List panel, as shown on page 4-278, to show information on the Token-Ring physical lines attached to an NCP and the associated TICs and logical lines.

ENTER=PHYSICAL LINE LIST

Depending on the adapter type, displays one of the following panels to show detailed information on the lines associated with a particular line adapter.

HPTSS or TSS Displays the ATUFC Physical Line List panel, as shown on page 4-94, for SDLC lines and, in NCP V6R1 or later releases, frame-relay lines.

ATUSC2 and ATUSC3 Line Adapters Panels

- TRA** In NCP V5R4 or later releases, displays the ATUTC Token-Ring Adapter List panel as shown on page 4-278.
- ETHER** In NCP V6R1 or later releases, displays the ATUEP Ethernet Adapter List panel as shown on page 4-81.

Place the cursor under the adapter number of the line adapter you want to view and press Enter.

F10=HEX

Displays the ATUDP Hexadecimal Storage Display panel as shown on page 4-68, to show the adapter information table (AIT).

F12=REFRESH

Refreshes the information on this panel.

PA1=EXIT

Exits NTuneMON.

PA2=LOG

Saves the information on this panel to the NetView log.

ATUSC4 3746 Model 900 Adapters Panel

Basic fast-path commands: SC4, 3746900, 3746, CSS, ODLC

Tuning fields: None

ATUSC4		A04NT06		3746 Model 900 Adapters				NTuneMON V2R1		15:16
POS	TYPE	LINEs		INST	OPER	ATTACH	UTIL	SDS	PDS	
2	CBSP	2048	2080	Y	OPER	Y	0	0	0	
3	CBTRP	2112	2144	Y	OPER	Y	0	0	0	
4	ESCP	2176	2208	Y	OPER	Y	0	3	65	
5	CLP	2240	2303	Y	OPER	Y	0	0	0	
6	CLP	2304	2367	Y	OPER	Y	0	0	0	
7	-	2368	-	-	-	Y	0	0	0	
8	-	2432	-	-	-	Y	0	0	0	
9	-	2496	-	-	-	Y	0	0	0	
10	-	2560	-	-	-	Y	0	0	0	
11	-	2624	-	-	-	Y	0	0	0	
12	-	2688	-	-	-	Y	0	0	0	
13	-	2752	-	-	-	Y	0	0	0	
14	-	2816	-	-	-	Y	0	0	0	
15	-	2880	-	-	-	Y	0	0	0	
16	-	2944	-	-	-	Y	0	0	0	
17	-	3008	-	-	-	Y	0	0	0	
18	-	3072	-	-	-	Y	0	0	0	
30	CBC1	-	-	Y	OPER	Y	1	3	83	
31	-	-	-	-	-	Y	0	0	0	

=>

F1=HELP F3=RETURN F6=ROLL F7=BACK F9=TOKEN-RING F10=HEX F11=NCP FUNCTION
ENTER=LINE DETAILS F12=REFRESH PA1=EXIT PA2=LOG

Figure 4-74. ATUSC4 3746 Model 900 Adapters Panel

Description

The ATUSC4 3746 Model 900 Adapters panel, which is available only for NCP V6R2 or later releases and only if the Model 900 Feature has been coded in the NCP generation, displays information on the communication adapters attached to the 3746 Model 900 connectivity subsystem (CSS) adapter for an NCP.

To display this panel:

- From the second PF key selection on the ATUCD CDS NCP Selection panel, as shown on page 4-27, press F10.
- From the third PF key selection on the ATUNW NCP Wide Selection panel, as shown on page 4-212, press F10.
- From the third PF key selection on the ATUSS Summary Status panel, as shown on page 4-260, press F10.
- From the ATUSC1 Channel Adapters panel, as shown on page 4-230, press F5.
- From the ATUSC2 Line Adapters Page 1 panel, as shown on page 4-233, press F5.
- From the ATUSC3 Line Adapters Page 2 panel, as shown on page 4-233, press F5.

Fields

NCP name (second field on panel)

Name of the NCP that is currently displayed. You can enter a different NCP name in this field to display information on another NCP.

The following columns on this panel show information for each adapter position:

POS

CSS adapter position.

TYPE

The type of communication adapter attached at each CSS adapter position. This can be any of the following:

- CBSP** Controller bus and service processor. This always appears in position 2.
- CBTRP** Controller bus and Token-Ring processor. This appears only in position 3.
- TRP** Token-Ring processor.
- ESCP** ESCON processor.
- CBC1** Controller bus coupler for the connection to the CCU. This is part of the CBSP and always appears in position 30.
- CBC2** Controller bus coupler for the connection to the second CCU in a twin-CCU configuration. This is part of the CBTRP and appears in position 31 when CBTRP appears in position 3.
- CLP** Communication line processor (NCP V6R3 or later releases).

Note: The TYPE field might show two processors installed when only a single processor exists. This is due to the hardware configuration when providing information to the NCP software. Please use the service processor to display the processors that are actually installed in the M900 frame.

LINEs

Line addresses for each CSS adapter position. These addresses are used as the value of the ADDRESS keyword on the LINE statement. (This is a range of addresses for all adapters.)

The line addresses are:

- Yellow if the 3746 Model 900 is installed and defined in the NCP generation
- Pink if the 3746 Model 900 is installed but is not defined in the NCP generation

INST

INST indicates that a communication adapter is installed. A dash (–) indicates that no communication adapter is installed.

OPER

OPER indicates that the communication adapter is operational. A dash (–) indicates that the communication adapter is not operational.

ATTACH

Y appears in all fields in this column to indicate that each position is attached to this CCU.

You might see two processors installed, when actually only a single processor exists. This is due to the hardware configuration when providing information to the NCP software. For actual processors installed in the M900 frame, please use the Service Processor to display the processors that are installed.

UTIL (starting with NCP V7R3)

Average processor utilization shown as a percentage from 0% to 100%. The 3746 Model 900 sends NCP this data every three minutes and 45 seconds.

SDS (starting with NCP V7R3)

Average shared data store (SDS) utilization shown as a percentage from 0% to 100%. The 3746 Model 900 sends NCP this data every three minutes and 45 seconds. SDS is similar to the NCP buffer pool.

PDS (starting with NCP V7R3)

Average program data store (PDS) utilization shown as a percentage from 0% to 100%. The 3746 Model 900 sends NCP this data every three minutes and 45 seconds.

PF Keys

F1=HELP

Displays online help for this panel.

F3=RETURN

Returns to the previous NTuneMON panel.

F6=ROLL

Returns to the NetView command line without exiting NTuneMON. To return to NTuneMON from the NetView program, press F6=ROLL or enter **ATUNEMON** on the NetView command line.

F7=BACK

Displays the ATUSC3 Line Adapters Page 2 panel, as shown on page 4-233, to show information on line adapters.

F9=TOKEN-RING (starting with NCP V6R2)

Displays the ATUTC Token-Ring Adapter List panel, as shown on page 4-278, to show information on the Token-Ring physical lines attached to an NCP and the associated TICs and logical lines.

F10=HEX

Displays the ATUDP Hexadecimal Storage Display panel, as shown on page 4-68, to show the adapter information table (AIT).

F11=NCP FUNCTION

Displays the ATUST NCP Function Activation panel, as shown on page 4-269, to display information about system network analysis program (snap) traces for NTRI, ODLC, and IP resources. Use the snap trace under the direction of your IBM service representative.

ENTER=LINE DETAILS

Depending on the adapter type, displays one of the following panels to show detailed information on the lines associated with a particular line adapter:

TRP or CBTRP Displays the ATUTP1 Token-Ring TIC Details Page 1 panel, as shown on page 4-310.

ESCP Displays the ATUCS 3746-900 Logical Lines panel as shown on page 4-43.

ATUSC4 3746 Model 900 Adapters Panel

- CLP** Displays the ATUFC Physical Line List panel, as shown on page 4-94, for SDLC lines, NEO lines, and:
- Starting with NCP V6R1, frame-relay lines.
 - Starting with NCP V7R4, X.25 lines.

Place the cursor under the line address you want, and press Enter.

F12=REFRESH

Refreshes the information on this panel.

PA1=EXIT

Exits NTuneMON.

PA2=LOG

Saves the information on this panel to the NetView log.

ATUSD SDLC Station Details Panel

Basic fast-path commands: None

Tuning fields: #PIUs/BLOCK, STATION, CONGESTION, RETRIES, PASSLIM, MAXDATA GEN, MAXOUT GEN, BLOCK GEN, PIUCHECK GEN, HPRQLIMIT

```

ATUSD A13SVTB          SDLC Station Details          NTuneMON V2R5    11:22
PU NAME = A13P48      SUBAREA = 4      NETID = NETA      TG = 2
PU STATUS = ACTIVE    NCP ROLE = PRIMARY  Subarea PU
#PIUs/BLOCK = 0      STATION = NORMAL
CONGESTION = NONE     MODE = NORMAL

-----
| FRAME STATISTICS:   | TRANSMIT | RECEIVE | CUR:  | GEN:  |
| TOTAL FRAMES       | 6073    | 2766    | PASSLIM = 254 | -    |
| TOTAL I-FRAMES     | 4349    | 2338    | MAXDATA = 521 | 521  |
| OUTSTANDING FRAME CNT: | 1      | -      | MAXOUT = 8    | 8    |
|                   |         |         | BLOCK = 0     | 0    |
|                   |         |         | PIUCHECK= NO  | NO   |
|                   |         |         | -----      |     |
| RETRIES = ( 7 , 0 , 0 ) |
|                   |         |         |
| POLLING            |
| Negative Polls =   | 196    | |
| Positive Polls =   | 1022   |
| Total Polls =      | 1218   |
|                   |         |         |
=> ATUM017 Press F12 to see Traffic or Polling rates
F1=HELP F3=RETURN F5=MODIFY F6=ROLL F10=HEX F12=REFRESH/TRAFFIC RATES
ENTER=TG DETAILS(SUBAREA ONLY) PA1=EXIT PA2=LOG
    
```

Figure 4-75. ATUSD SDLC Station Details Panel

Description

The ATUSD SDLC Station Details panel displays detailed information on a particular SDLC station.

To display this panel: On the ATUSL SDLC Stations List panel, as shown on page 4-246, place the cursor under a station and press Enter.

Fields

NCP name (second field on panel)

Name of the NCP that is currently displayed.

Elapsed Time

The amount of time that has passed from panel entry until the panel is refreshed or the amount of time that has passed since the statistics were last refreshed.

PU NAME

PU name. For NCP V4R1 and NCP V4R2, this field will be blank. For NCP V6R1 or earlier releases, a dash (-) appears in this field.

SUBAREA (subarea stations)

Adjacent subarea address. This appears as N/A for peripheral stations or if the adjacent subarea information is not available.

NETID

For subarea stations, the network identifier (NETID) of the adjacent NCP. For peripheral stations, the NETID of the station at the other end of the link.

ATUSD SDLC Station Details Panel

TG

The transmission group number as defined by TGN on the PU statement.

PU STATUS

Status of the PU. This can be any of the following:

ACTIVE	Active (normal data)
INACTIVE	Reset
XID PEND	XID pending with data
XID NODT	XID pending without data
CONT PND	Contact pending
DISC PND	Discontact pending
PENDING	Contact and discontact pending
LOAD/DMP	Load/Dump/RPO active
SIM PEND	Set initialization mode pending
LL2 ACT	Link-level 2 active
LL2 PND	Link-level 2 pending
INACT PD	Free-resource operation pending

NCP ROLE

This is NCP's role with respect to the station at the other end of the link (primary, secondary, or configurable).

Station Type

SUBAREA PU or PERIPHERAL PU

#PIUs/BLOCK

Maximum number of PIUs for each frame as defined by the *pius* suboperand of the BLOCK keyword on the PU statement.

STATION (starting with NCP V7R6)

Whether the station can be used for hot standby (STANDBY) or cannot (NORMAL), as defined by the TGCONF keyword on the PU definition statement.

CONGESTION (starting with NCP V7R6)

The station's role in congestion relief as defined by the third parameter of the TGCONF keyword on the PU definition statement:

- If the station can be used to relieve congestion, this field displays the station's threshold percentage.
- If the station can be used as a standby station but not to relieve congestion, this field displays NONE.
- If the station cannot be used as a standby station, this field displays N/A.

MODE (starting with NCP V7R6)

Whether the station is in standby mode (STANDBY) or normal mode (NORMAL).

FRAME STATISTICS

The following information is displayed for Transmit and Receive frames:

TOTAL FRAMES

Number of frames transmitted and received with traffic rate (that is, per second).

TOTAL I-FRAMES

Number of I-frames transmitted and received with traffic rate (that is, per second).

OUTSTANDING FRAME CNT

Number of frames waiting for acknowledgement from the other end (number of frames outstanding).

RETRIES(m, t, n)

Number of attempts to be made to recover from errors occurring during transmission over the link. Defined by the RETRIES keyword on the PU statement. Each attempt at recovery, or *retry*, is a retransmission of data or control commands. NCP performs retries until the transmission is successful or the number of retries reaches the maximum specified by this keyword.

Retries are performed in sets, which are called *retry sequences*. NCP can perform one or more retry sequences. Successive retry sequences are separated by pauses.

RETRIES(m)

Maximum number of retries in each retry sequence as defined by the *m* suboperand of the RETRIES keyword on the LINE statement.

RETRIES(t)

Pause interval, in seconds, between successive retry sequences as defined by the *t* suboperand of the RETRIES keyword on the PU statement.

RETRIES(n)

Maximum number of retry sequences as defined by the *n* suboperand of the RETRIES keyword on the PU statement.

POLLING

This section of the panel displays statistics for negative, positive, and total polls. When this panel is first entered, polls are displayed as numbers. When F12 is pressed, polls are displayed as polls per second (*n*/Sec). However, any polls that are less than one per second are displayed as numbers.

Negative polls or Neg polls/Sec (not available for 3746 Model 900)

NCP sent out a signal and either did not get a response or received a request for retransmission of the last data sent. This indicates that either the station is not available to respond or an error occurred.

Positive polls or Pos polls/Sec (not available for 3746 Model 900)

NCP sent out a signal and got data.

Total polls or Total polls/Sec (not available for 3746 Model 900)

Sum of positive and negative polls.

Notes:

1. **3746 Model 900 (all NCP releases):** A dash (–) is displayed in these fields instead of poll counts.
2. **NCP V7R2 or later releases (except 3746 Model 900):** When the line is inactive, a zero (0) is displayed in these fields because no polling is taking place.
3. **NCP V7R1 or earlier releases (except 3746 Model 900):** A dash (–) is displayed in these field instead of poll counts.
4. If polling data is not currently being collected and if you have NTuneNCP included in your NCP, you can use the ATUST NCP Function Activation panel to activate polling data collection (NTUNECOL). Type POLL on the command

line and press Enter to fast-path to the ATUST NCP Function Activation panel as shown on page 4-269.

CUR GEN

CUR fields are the current working values that are either set or limited by the corresponding GEN field. GEN fields are either values from the NCP generation or values determined by subsequent NCP processing.

PASSLIM CUR GEN

Current (CUR) and generated (GEN) values of the maximum number of consecutive PIUs to be sent at one time to a device, as defined by the PASSLIM keyword on the PU statement.

Note: PASSLIM GEN appears as a dash (-) for subarea stations because NTuneMON does not have access to the value.

MAXDATA CUR (starting with NCP V5R4)

Current maximum inbound frame size for the destination station. This field is a working value that is either set or limited by the MAXDATA GEN field.

MAXDATA GEN (starting with NCP V5R4)

Generated maximum inbound frame size for the destination station. Gen is either the value from the NCP generation (MAXDATA keyword on the PU statement) or the value resulting from subsequent NCP processing that overwrote the generated value.

MAXOUT CUR

Current maximum number of frames NCP can send to the destination station before requiring an acknowledgement. This field is a working value that is either set or limited by the MAXOUT GEN field.

MAXOUT GEN

Generated maximum number of frames that NCP can send to the destination station before requiring an acknowledgement. GEN is either the value from the NCP generation (MAXOUT keyword on the PU statement) or the value resulting from subsequent NCP processing that overwrote the generated value.

BLOCK CUR

Current maximum frame size, as defined by the *bytes* suboperand of BLOCK on the PU statement.

BLOCK GEN

Generated (GEN) maximum frame size, as defined by the *bytes* suboperand of BLOCK on the PU statement.

PIUCHECK CUR (starting with NCP V7R7; subarea stations only)

Current YES or NO value indicating whether a checksum validation is performed on PIUs sent from and received by this station. This field is a working value that is either set or limited by the PIUCHECK GEN field for this station and the adjacent link station.

PIUCHECK GEN (starting with NCP V7R7; subarea stations only)

Generated YES or NO value indicating whether a checksum validation is performed on PIUs sent from and received by this station. Unless tuned, this field is the value from the NCP generation (PIUCHECK keyword on the PU statement).

HPR DATA**HPRQLIMIT (starting with NCP V7R3; peripheral)**

Maximum number of bytes of HPR data that can be queued to the peripheral link station's transmission queue at one time as defined by the HPRQLIM keyword on the PU statement.

HPR bytes queu (starting with NCP V7R3)

Number of bytes on the HPR queue.

X-NLPs discard (starting with NCP V7R3)

Number of network layer packets (NLPs) that have been discarded because of queue overrun.

R-NLPs discard (starting with NCP V7R3)

Number of NLPs received that have been discarded because of node congestion.

PF Keys**F1=HELP**

Displays online help for this panel.

F3=RETURN

Returns to the previous NTuneMON panel.

F5=MODIFY

Available when the operator has tuning authority and NTuneNCP is included. For more information, refer to Chapter 5, Using the NTuneNCP Tuning Feature.

Updates the NCP tuning parameter with the modified value. If the modification is not valid, the field turns reverse-video pink, and you are prompted to correct the value and resubmit it.

F6=ROLL

Returns to the NetView command line without exiting NTuneMON. To return to NTuneMON from the NetView program, press F6=ROLL or enter **ATUNEMON** on the NetView command line.

F10=HEX

Displays the ATUDP Hexadecimal Storage Display panel, as shown on page 4-68, to show the common physical unit control block (CUB) for peripheral stations or the station control block (SCB) for subarea stations.

F12=REFRESH/TRAFFIC RATES

Refreshes the information on this panel to display polls per second instead of the number of polls since the last time the poll counter field wrapped.

ENTER=TG DETAILS(SUBAREA ONLY)

Displays the ATUML Multi-Link Transmission Group panel, as shown on page 4-184, to show more information about the transmission group and the origin and destination NCPs.

PA1=EXIT

Exits NTuneMON.

PA2=LOG

Saves the information on this panel to the NetView log.

ATUSL SDLC Stations List Panel

Basic fast-path commands: None

Tuning fields: None

```

ATUSL A71NT05 SDLC Stations List NTuneMON V2R1 15:21
Physical Line Addr = 36 Name = A71LN36 Status = INACTIVE Total = 1
                PASSLIM MAXOUT | FrameMAXDATA
Addr  Type Name      Status  Cur   Cur | Cnt  Cur  SUB.TG  NCP Role
193(C1) T2  A71PU36A INACTIVE  0     0  |  0   0    N/A    PRIMARY

=>
ENTER=DETAILS F1=HELP F3=RETURN F6=ROLL F7=BCK F8=FWD F10=HEX F12=RFRSH PA2=LOG
    
```

Figure 4-76. ATUSL SDLC Stations List Panel

Description

The ATUSL SDLC Stations List panel displays information on the stations associated with a single SDLC physical line.

To display this panel:

- On the ATUFC Physical Line List panel, as shown on page 4-94, place the cursor under a line address and press F9.
- From the ATUPL SDLC Physical Line Details panel, as shown on page 4-217, press Enter.
- From the ATUSP1 SDLC Peripheral Line Parameters Page 1 panel, as shown on page 4-249, or from the ATUSP2 SDLC Peripheral Line Parameters Page 2 panel, as shown on page 4-255, press Enter.

Fields

NCP name (second field on panel)

Name of the NCP that is currently displayed.

Physical Line Addr

Line address, as defined by the ADDRESS keyword on the LINE statement.

Name

Name of the SDLC physical line. For NCP V4R1 and NCP V4R2, this field will be blank.

Status

Physical line status: ACTIVE or INACTIVE.

Total

Total number of PUs on this line.

The following columns on this panel show information for each PU:

Addr

Address of the PU, as defined by the ADDR keyword on the PU statement. This address is displayed in decimal and hexadecimal.

For subarea connections, the Addr field might display a different address from what was coded due to primary and secondary configurations.

Type

PU type: T1 (type 1), T2 (type 2), T2.1 (type 2.1) or T4 (type 4).

Name

Name of the PU. For NCP V4R1 and NCP V4R2, this field will be blank. For NCP V6R1 or earlier releases, a dash (-) appears in this field.

Status

Status of the PU. Can be any of the following:

INACTIVE	Reset
XID PEND	XID pending with data
XID NODT	XID pending without data
CONT PND	Contact pending
PENDING	Contact and discontact pending
ACTIVE	Active (normal data)
LOAD/DMP	Load/Dump/RPO active
SIM PEND	Set initialization mode pending
DISC PND	DISC pending
LL2 ACT	Link-level 2 active
INOP PND	INOP pending
LL2 PND	Link-level 2 pending
INACT PD	Free-resource operation pending

PASSLIM Cur

Number of consecutive PIUs to be sent at one time to a device, as defined by the PASSLIM keyword on the PU statement.

MAXOUT Cur

Current maximum number of frames NCP can send to the destination station before requiring an acknowledgement, This value may be less than the defined value because NCP reduces the current value if it detects congestion.

Frame Cnt

Number of frames waiting for acknowledgement from the other end (number of frames outstanding).

MAXDATA Cur

Current maximum inbound frame size for the destination station, as defined by the MAXDATA keyword on the PU statement.

SUB.TG

Subarea address and transmission group number.

For a type 4 PU, NTuneMON displays the subarea address and

ATUSL SDLC Stations List Panel

transmission group number (in the form *sa.tgn*) if the PU has been contacted and is active. Otherwise, NTuneMON displays only the transmission group number (in the form *TGN=tgn*). The transmission group number is defined by the TGN keyword on the PU statement.

NCP Role

This is NCP's role with respect to the station at the other end of the link (primary, secondary, or configurable).

PF Keys

ENTER=DETAILS

Displays the ATUSD SDLC Station Details panel, as shown on page 4-241, to show more details on a particular SDLC station. Place the cursor under a station and press Enter.

F1=HELP

Displays online help for this panel.

Note: This information is not displayed for CLP adapters.

F3=RETURN

Returns to the previous NTuneMON panel.

F6=ROLL

Returns to the NetView command line without exiting NTuneMON. To return to NTuneMON from the NetView program, press F6=ROLL or enter **ATUNEMON** on the NetView command line.

F7=BCK

Scrolls the panel data backward one screen.

F8=FWD

Scrolls the panel data forward one screen.

F10=HEX

Displays the ATUDP Hexadecimal Storage Display panel, as shown on page 4-68, to show the common PU block (CUB) for peripheral stations or the station control block (SCB) for subarea stations.

F12=REFRESH

Refreshes the information on this panel.

PA1=EXIT

Exits NTuneMON.

PA2=LOG

Saves the information on this panel to the NetView log.

ATUSP1 SDLC Peripheral Line Parameters Page 1 Panel

Basic fast-path commands: None

Tuning fields: NCP USE, VTAM USE, ANSTONE, CCLID, CLOCKNG, DATRATE, DUPLEX, HISPEED, NEWSYNC, NRZI, RING, SPEED, TRANSFR, X21NTWK

```

ATUSP1  A71NT05                               NTuneMON V2R1   07:27
          SDLC Peripheral Line Parameters Page 1

Configuration Parameters for Line A71LN36 Element Address 0022

Status = INACTIVE                               Line Type = TSS
NCP USE = NON-REDEF                             Line Addr = ( 36 , FULL )
VTAM USE = NON-REDEF

ANSTONE = N/A                                  MODE = PRI
AUTO = N/A                                     NEWSYNC = NO
CCLID = N/A                                   NRZI = NO
CLOCKNG = EXT                                  RING = N/A
DATRATE = LOW                                  SPEED = 2400
DIAL = NO                                     TRANSFR = 205
DUPLEX = FULL                                 V25BIS = NO
HISPEED = NO                                  X21NTWK = NO
LPDATS = NO                                   X21SW = NO
LPDA2DL = NO

=> ATUM704 Use VERIFY before MODIFY,ACT or MODIFY. See HELP (F1).
F1=HELP F2=VERIFY F3=RETURN F4=MODIFY,ACT F5=MODIFY F6=ROLL F8=FORWARD
ENTER=STATIONS(PUs) F10=HEX F11=LINE DETAILS F12=REFRESH PA1=EXIT PA2=LOG

```

Figure 4-77. ATUSP1 SDLC Peripheral Line Parameters Page 1 Panel

Description

The ATUSP1 SDLC Peripheral Line Parameters Page 1 panel, and the ATUSP2 SDLC Peripheral Line Parameters Page 2 panel as shown on page 4-255, can be used together to display and update information about various parameters for SDLC peripheral lines.

The ATUSP1 SDLC Peripheral Line Parameters Page 1 panel displays and allows you to update information about various configuration parameters.

To display this panel:

- On the ATUFC Physical Line List panel, as shown on page 4-94, place the cursor under a peripheral SDLC line and press F4.
- From the ATUPL SDLC Physical Line Details panel, as shown on page 4-217, press F4.
- From the ATUSP2 SDLC Peripheral Line Parameters Page 2 panel, as shown on page 4-255, press F7.

Fields

NCP name (second field on panel)

Name of the NCP that is currently displayed.

Configuration Parameters for Line name Element Address n

- *name* is the name of the line
- *n* is the line's element address

Status

Status of the line. Status can be any of the following:

PEND ACTLINK An activate link command (ACTLINK) is in progress.

ACTIVE An ACTLINK has been processed, and the line is active.

PEND DACTLNK A deactivate link command (DACTLINK) is in progress.

INACTIVE A DACTLINK has been processed, and the line is inactive. Inactive lines are highlighted in reverse-video red.

FORCE DEACT The line has been forced into deactivation. (A force deactivate command was issued from VTAM.)

PEND ANS Line quiescence is pending due to automatic network shutdown (ANS).

PEND SWITCH A switch from primary to secondary is in progress.

OLT TESTING Online line testing (OLT) is in progress.

WRAP TESTING Wrap testing is in progress.

NCP USE

Specifies the current use of the line, as defined by the USE keyword on the LINE statement as follows:

NON-REDEF

Specifies the line is currently in use and is not capable of being changed to a spare line.

REDEF

Specifies the line is currently in use, but is capable of being changed to a spare line.

SPARE

Specifies the line is not currently in use and cannot be activated unless it is first modified to a REDEF line.

VTAM USE

The current use of the line, as defined by the USE keyword on the LINE statement, from VTAM's perspective, as follows:

NON-REDEF

Specifies the line is currently in use and is not capable of being changed to a spare line.

REDEF

Specifies the line is currently in use but is capable of being changed to a spare line.

SPARE

Specifies the line is not currently in use and will not be activated by VTAM unless it is first modified to a REDEF line.

Line Type

Line adapter type: TSS (low speed), HPTSS (high speed), or CLP (for the 3746 Model 900).

Line Addr

Address of this line, as defined by the ADDRESS keyword on the LINE statement. The address is followed by FULL is the line is full-duplex, or HALF is the line is half-duplex.

ANSTONE

Whether NCP transmits an answer tone to the calling device to signify completion of the line connection, as defined by the ANSTONE keyword on the LINE statement. Used only for incoming calls on switched lines.

AUTO

Whether there is an automatic calling unit (ACU) on the line, as defined by the AUTO keyword on the LINE statement. AUTO is normally used when the callout operation is performed.

CCLID

Specifies that NCP is to support called-calling ID (CCLID), as defined by the CCLID keyword on the LINE statement. Used for switched X.21 lines.

CLOCKNG

Whether the modem (data set) or the communication scanner for the line provides the clocking, as defined by CLOCKNG keyword on the LINE statement.

DIRECT

The scanner provides clocking and propagates it to the attached DTE. The data signal received by the controller is synchronized with the controller's clock. You must use a directly attached cable.

EXT

The modem or other external source provides clocking. You can use either a directly attached cable or a modem cable.

INT

The scanner provides clocking but does not propagate it to the attached data terminal equipment (DTE). The scanner synchronizes the received data signal; a different clock is used at each end of a link. You can use either a directly attached cable (no modem) or a modem cable.

DATRATE

The rate that NCP is to use for a link attached to a dual-rate modem, as defined by the DATRATE keyword on the LINE statement.

DIAL

Whether the line is switched (DIAL=YES) or leased (DIAL=NO), as defined by the DIAL keyword on the GROUP statement.

DUPLEX

Whether the communication line and modem constitute a half-duplex or a duplex facility, as defined by the DUPLEX keyword on the LINE statement.

Duplex is applicable only when Line Addr=(n, HALF). DUPLEX=HALF means the RTS signal is active only when NCP is sending data. DUPLEX=FULL means the RTS signal is active when NCP is sending or receiving data.

Note: Do not confuse this with half-duplex or duplex data transfer. DUPLEX specifies only the physical characteristics of the communication facility, and is used to control the request-to-send (RTS) signal.

HISPEED

Whether this line operates at speeds of 144 Kbps or greater, as defined by the HISPEED keyword on the LINE statement. Used only for TSS lines.

LPDATS

Whether the line uses modems that support LPDA commands, and whether the modems operate in normal (LPDATS=LPDA2) or migration (LPDATS=LPDA1 or LPDATS=LPDA1,3867) mode. Used for lines with externally clocked modems that support the LPDA facility. Defined by the LPDATS keyword on the LINE statement.

LPDA2DL

Whether the line uses modems that are not actually LPDA2 modems, but that can support the LPDA2 modem dial facility. Used for lines with externally clocked modems. Defined by the LPDA2DL keyword on the LINE statement.

MODE

The mode of operation of a line, as defined by the MODE keyword on the GROUP statement as follows:

- NEG** Role of the line is currently negotiable.
- PRI** NCP has the primary role for this line.
- SEC** NCP has the secondary role for this line.

NEWSYNC

Whether the communication controller supplies the new-sync signal to the modem (data set) on this line, as defined by the NEWSYNC keyword on the LINE statement.

NRZI

YES or NO to specify whether the data terminal equipment at the end of the SDLC link must operate in non-return-to zero change-on-ones mode (YES) or in non-return-to-zero mode (NO). Defined by the NRZI keyword on the LINE statement.

RING

Whether the ring-indicator mode of an automatic answer operation is used, as defined by the RING keyword on the LINE statement. This decision depends upon the type of modem (data set) that connects the link to the controller.

SPEED

Data rate for the line in bits per second, as defined by the *rate* suboperand of the SPEED keyword on the LINE statement. This is the rate at which the devices communicate with the communication controller.

NCP V7R6 and Earlier Releases: The SPEED value displayed on this panel might differ from the rate specified for the SPEED keyword:

For TSS and HPTSS adapters with CLOCKNG=EXT, following are the displayed values for SPEED. These values are valid only for NCP V5R4 and later, running on a 3745.

50, 75, 100, 110, 134, 200, 300, 600, 1200, 2400, 4800, 9600,
19200, 38400, 55855, 245760, 1843200

If a value in the above list was specified for SPEED, the panel displays that value. If an unlisted value less than 1843200 was specified for SPEED, the panel displays the next highest listed value. For

example, if 60 was specified, the panel displays 75. If a value greater than 1843200 was specified for SPEED, the panel displays 1843200.

For 3746 Model 900 lines with CLOCKNG=EXT, the value displayed for SPEED represents a range of speeds as shown in Table 4-3.

Table 4-3. SPEED Values for IBM 3746 Model 900 SDLC Lines when CLOCKNG=EXT and VERSION<V7R7

Displayed SPEED Value	Actual Data Rate (SPEED) Values for CLOCKNG=EXT
19200	>= 600 and <= 32000
38400	> 32000 and <= 64000
256000	> 64000 and <= 256000
512000	> 256000

TRANSFR

The number of NCP buffers corresponding to the maximum amount of data (the data transfer limit) that NCP can receive from the line during a single data transfer operation. Defined by the TRANSFR keyword on the LINE statement.

V25BIS

Whether the modem for the line supports the V.25 bis protocol and which line protocol is used for the dial connection, as defined by the V25BIS keyword on the LINE statement.

X21NTWK

Whether this line is attached to an X.21 network and specifies the level of the X.21 network, as defined by the X21NTWK keyword on the GROUP statement.

X21SW

Whether the line is an X.21 switched line, as defined by the X21SW keyword on the GROUP statement.

PF Keys

F1=HELP

Displays online help for this panel.

F2=VERIFY

Available when the operator has tuning authority and NTuneNCP is included.

Verifies that all the changes made on the ATUSP1 SDLC Peripheral Line Parameters Page 1 and ATUSP2 SDLC Peripheral Line Parameters Page 2 panels, as shown on pages 4-249 and 4-255, are within range and consistent with other related parameters. Changes that are either not in range or not consistent are highlighted in reverse-video pink and are recorded in the NetView log. No changes are sent to NCP with this key. Use F4 or F5 to send changes.

Important: You must verify any values you have changed on this panel before exiting this panel; otherwise, the changes are lost.

F3=RETURN

Returns to the previous NTuneMON panel.

F4=MODIFY,ACT or F4=DEACTIVATE

Available when the operator has tuning authority and NTuneNCP is included.

F4=MODIFY,ACT verifies and updates NCP tuning parameters with the modified values and activates the line. If the modification is not valid, the field turns reverse-video pink, and you are prompted to correct the value and resubmit the request. F4=DEACTIVATE uses the VTAM FORCE DEACTIVATION option to deactivate the line so that tuning changes can be made.

Important: See the description of F2=VERIFY before using this key.

F5=MODIFY

Available when the operator has tuning authority and NTuneNCP is included. For more information, refer to Chapter 5, Using the NTuneNCP Tuning Feature.

Updates the NCP tuning parameter with the modified value. If the modification is not valid, the field turns reverse-video pink, and you are prompted to correct the value and resubmit it.

Important: See the description of F2=VERIFY before using this key.

F6=ROLL

Returns to the NetView command line without exiting NTuneMON. To return to NTuneMON from the NetView program, press F6=ROLL or enter **ATUNEMON** on the NetView command line.

F8=FORWARD

Scrolls forward to the ATUSP2 SDLC Peripheral Line Parameters Page 2 panel, as shown on page 4-255.

ENTER=STATIONS(PUs)

Displays the ATUSL SDLC Stations List panel as shown on page 4-246.

F10=HEX

Displays the ATUDP Hexadecimal Storage Display panel, as shown on page 4-68, to show the line control block (LKB).

F11=LINE DETAILS

Displays the ATUPL SDLC Physical Line Details panel, as shown on page 4-217.

F12=REFRESH

Refreshes the information on this panel.

PA1=EXIT

Exits NTuneMON.

PA2=LOG

Saves the information on this panel to the NetView log.

ATUSP2 SDLC Peripheral Line Parameters Page 2 Panel

Basic fast-path commands: None

Tuning fields: ACTIVTO, ETRATIO, RNRLIMIT, SRETRY, REDIAL, RETRIES, REPLYTO, RETRYTO, TEXTTO, XMITDLY, PAUSE, LSPRI, SERVLIM, HDXSP

```

ATUSP2  A71NT05  NTuneMON V2R1  07:32
SDLC Peripheral Line Parameters Page 2

Line A71LN36 Element Address 0022

Error Recovery Processing Parameters

ACTIVTO = 60.0          REPLYTO = 60.0
ETRATIO = 30           RETRYTO = N/A
RNRLIMIT = 3          TEXTTO = 3.0
SRETRY = N/A          XMITDLY = N/A
REDIAL = ( 0 , 0 , 0 , 0 )
RETRIES = ( 5 , 255 , 20 )

Performance and Tuning Parameters

PAUSE = ( 1.0 , 2.8 )  LSPRI = PU  SERVLIM = 4  HDXSP = N/A

=>
F1=HELP F2=VERIFY F3=RTN F4=MODIFY,ACT F5=MODIFY F6=ROLL F7=BACK F9=MOD TIMER
ENTER=STATIONS(PUs) F10=HEX F11=LINE DETAILS F12=REFRESH PA1=EXIT PA2=LOG
    
```

Figure 4-78. ATUSP2 SDLC Peripheral Line Parameters Page 2 Panel

Description

The ATUSP1 SDLC Peripheral Line Parameters Page 1 panel and the ATUSP2 SDLC Peripheral Line Parameters Page 2 panel, as shown on page 4-255, can be used together to display and update information about various parameters for SDLC peripheral lines.

The ATUSP2 SDLC Peripheral Line Parameters Page 2 panel displays error recovery processing parameters and performance and tuning parameters.

To display this panel: On the ATUSP1 SDLC Peripheral Line Parameters Page 1 panel, as shown on page 4-249, press F8.

Fields

NCP name (second field on panel)

Name of the NCP that is currently displayed.

Line xxxxxx Element Address nnnn

- xxxxxx is the name of the line
- nnnn is the line's element address.

Error Recovery Processing Parameters

ACTIVTO

Specifies, in seconds, how long the secondary NCP is to wait for communication from the primary NCP before initiating shutdown. Defined by the ACTIVTO keyword on the GROUP statement.

ETRATIO

Specifies the error-to-transmission ratio (the ratio of the number of errors to the number of transmissions), as defined by the ETRATIO keyword on the LINE statement. This ratio is used by programs that analyze statistical maintenance records.

Specifies the ratio in 10ths of a percent; for example ETRATIO=125 indicates a ratio of 12.5%.

RNRLIMIT

Specifies, in minutes, how long NCP is to allow a station to refuse to accept data before identifying the station as inoperative. Defined by the RNRLIMIT keyword on the GROUP statement. For example, a station is identified as inoperative if it responds with a receive-not-ready (RNR) command to every poll sent by NCP during the specified interval.

SRETRY

Specifies the number of retries to be attempted when a physical unit becomes secondary, as defined by the SRETRY keyword on the LINE statement.

REDIAL(m, t1, n, t2)

Determines the timing and maximum number of dialing operations NCP performs in attempting to reach a device over a switched line. Defined by the REDIAL keyword on the LINE statement. NCP performs dialing operations in sequences, with a pause between dialing operations in each sequence and a pause between sequences.

REDIAL(m)

For SDLC lines, specifies the number of dialing operations in each sequence, (m); (m) is provided by the access method.

REDIAL(t1)

Specifies, in seconds, the pause between dialing operations in each sequence, as defined by the *t1* suboperand of the REDIAL keyword on the LINE statement.

REDIAL(n)

Determines the maximum number of dialing sequences, as defined by the *n* suboperand of the REDIAL keyword on the LINE statement.

REDIAL(t2)

Specifies, in seconds, the pause between dialing sequences, as defined the *t2* suboperand of the REDIAL keyword on the LINE statement.

RETRIES(m, t, n)

Specifies the number of attempts to be made to recover from errors occurring during transmission over the link, as defined by the RETRIES keyword on the LINE statement. Each attempt at recovery, or *retry*, is a retransmission of data or control commands. NCP performs retries until the transmission is successful or the number of retries reaches the maximum specified by this keyword.

Retries are performed in sets, which are called *retry sequences*. NCP can perform one or more retry sequences. Successive retry sequences are separated by pauses.

RETRIES(m)

Specifies the maximum number of retries in each retry sequence, as defined by the *m* suboperand of the RETRIES keyword on the LINE statement.

RETRIES(t)

Specifies the pause interval, in seconds, between successive retry sequences, as defined by the *t* suboperand of the RETRIES keyword on the LINE statement.

Note: The *t*, on the LINE statement, serves as a default value to be used for DR-added PUs for which VTAM does not provide NCP with a value for *t*. The *t*, as coded on the PU statement, is the value which is actually used. See the ATUSD SDLC Station Details panel, as shown on page 6-113, for more information.

RETRIES(n)

Specifies the maximum number of retry sequences, as defined by the *n* suboperand of the RETRIES keyword on the LINE statement.

Note: The *n*, on the LINE statement, serves as a default value to be used for DR-added PUs for which VTAM does not provide NCP with a value for *n*. The *n*, as coded on the PU statement, is the value which is actually used. See the ATUSD SDLC Station Details panel, as shown on page 6-113, for more information.

REPLYTO

Specifies the reply time out value or values for the lines, as defined by the REPLYTO keyword on the GROUP statement. If NCP does not receive a response to a poll, selection, or message text before specified time expires, a time-out error is indicated and the appropriate error recovery procedure is started.

For switched SDLC lines, NCP uses the interval specified by XMITDLY on this GROUP statement as the reply time out value during initial XID exchange. In other cases, NCP uses the value of REPLYTO.

RETRYTO

Specifies, in seconds, how long NCP is to wait after receiving a retry call progress signal (CPS) before retrying a callout, as defined by the RETRYTO keyword on the GROUP statement.

TEXTTO

Specifies the text time-out value, in seconds, for the line, as defined by the TEXTTO keyword on the GROUP statement.

XMITDLY

Specifies, in seconds, how long NCP is to delay its initial transmission after answering an incoming call, as defined by the XMITDLY keyword on the GROUP statement. The value of XMITDLY is used as the reply time-out value during initial XID exchange.

Performance and Tuning Parameters

PAUSE(t1, t2)

Specifies the delay in seconds between successive polling cycles, as defined by the PAUSE keyword on the LINE statement.

PAUSE(t1)

Specifies the pause for this line, if the line is operating as a modulo-8 line. Defined by the *t1* suboperand of the PAUSE keyword on the LINE statement.

PAUSE(t2)

Specifies the pause for this line, if the line is operating as a modulo-128 line. Defined by the *t2* suboperand of the PAUSE keyword on the LINE statement.

LSPRI

Whether transmission priority is to be used to determine the order in which PIUs are transmitted to the PU, as defined by the LSPRI keyword on the LINE statement.

SERVLIM

Specifies the maximum number of regular scans of the service order table (SOT) that NCP is to make for normal servicing of physical and logical units on the link before it makes a special scan of the table. Defined by the *entries* suboperand of the SERVLIM keyword on the LINE statement.

HDXSP

Whether sending data to a terminal has priority over polling. This choice is defined by the HDXSP keyword on the LINE statement. HDXSP applies only to SDLC links that have one line interface address (half-duplex) and have more than one active device.

PF Keys

F1=HELP

Displays online help for this panel.

F2=VERIFY

Available when the operator has tuning authority and NTuneNCP is included.

Verifies that all the changes made on the ATUSP1 SDLC Peripheral Line Parameters Page 1 and ATUSP2 SDLC Peripheral Line Parameters Page 2 panels, as shown on pages 4-249 and 4-255, are within range and consistent with other related parameters. Changes that are either not in range or not consistent are highlighted in reverse-video pink and are recorded in the NetView log. No changes are sent to NCP with this key. Use F4 or F5 to send changes.

Important: You must verify any values you have changed on this panel before exiting this panel; otherwise, the changes are lost.

F3=RTN

Returns to the NTuneMON panel.

F4=MODIFY,ACT or F4=DEACTIVATE

Available when the operator has tuning authority and NTuneNCP is included.

F4=MODIFY,ACT verifies and updates NCP tuning parameters with the modified values and activates the line. If the modification is not valid, the field turns reverse-video pink, and you are prompted to correct the value and

resubmit the request. F4=DEACTIVATE uses the VTAM FORCE DEACTIVATION option to deactivate the line so that tuning changes can be made.

Important: See the description of F2=VERIFY before using this key.

F5=MODIFY

Available when the operator has tuning authority and NTuneNCP is included. For more information, refer to Chapter 5, Using the NTuneNCP Tuning Feature.

Updates the NCP tuning parameter with the modified value. If the modification is not valid, the field turns reverse-video pink, and you are prompted to correct the value and resubmit it.

Important: See the description of F2=VERIFY before using this key.

F6=ROLL

Returns to the NetView command line without exiting NTuneMON. To return to NTuneMON from the NetView program, press F6=ROLL or enter **ATUNEMON** on the NetView command line.

F7=BACK

Scrolls back to ATUSP1 SDLC Peripheral Line Parameters Page 1 panel, as shown on page 4-249.

F9=MOD TIMER (if the line is the only one defined for the GROUP statement)

Displays the ATUMT Modify Timer Value panel, as shown on page 4-189, when the cursor is placed on one of the following keywords provided that the field value is displayed in yellow.

REPLYTO, RETRYTO, TEXTTO, XMITDLY

To choose a new timer value for that keyword, use the ATUMT panel.

ENTER=STATIONS(PUs)

Displays the ATUSL SDLC Stations List panel as shown on page 4-246.

F10=HEX

Displays the ATUDP Hexadecimal Storage Display panel, as shown on page 4-68, to show the line control block (LBK).

F11=LINE DETAILS

Displays the ATUPL SDLC Physical Line Details panel, as shown on page 4-217.

F12=REFRESH

Refreshes the information on this panel.

PA1=EXIT

Exits NTuneMON.

PA2=LOG

Saves the information on this panel to the NetView log.

ATUSS Summary Status Panel

Basic fast-path commands: SS, SUM, SUMMARY
 Tuning fields: None

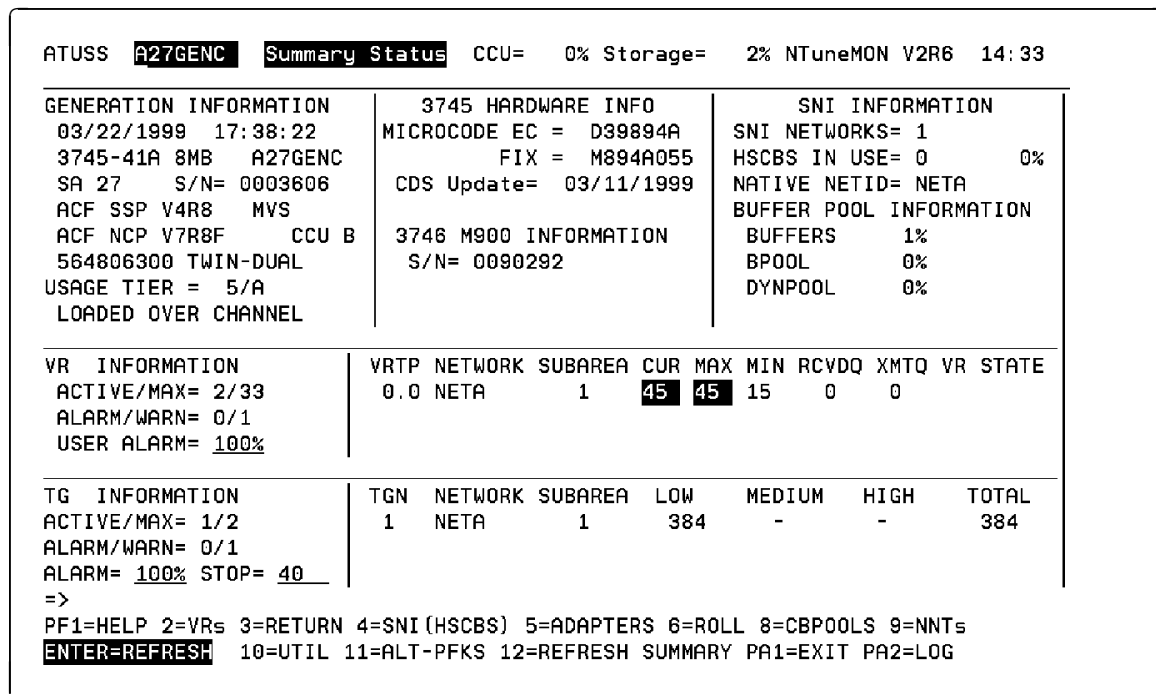

Figure 4-79. ATUSS Summary Status Panel

Description

The ATUSS Summary Status panel gives an overview of a single NCP, including generation information, control block pools and tables, SNI information, virtual routes, and transmission groups.

To display this panel:

- From the ATUNP NCP Selection panel, as shown on page 4-204, press Enter.
- From the ATUCD CDS NCP Selection panel, as shown on page 4-27, press Enter.
- From the ATUNW NCP Wide Selection panel, as shown on page 4-212, press Enter.

Fields

NCP name (second field on panel)

Name of the NCP that is currently displayed. You can enter a different NCP name in this field to display information about another NCP.

CCU

Percentage of controller CCU cycles in use.

Storage

Percentage of controller buffer storage in use.

GENERATION INFORMATION

This section of the panel provides general information on NCP generation. Some of this information is defined by keywords on the BUILD statement. Other information is defined automatically through MOSS.

- **NCP generation date and time**, as defined by the GENLEVEL keyword on the BUILD statement. This value depends on what was coded for GENLEVEL; therefore, it might not be the actual NCP generation date and time (GENDATE). (If GENLEVEL was not coded the default is the date and time the generation was run.) NTuneMON uses the value in this field to determine whether the NCP was reloaded. If you have reloaded a new NCP and GENLEVEL was specified and has not been changed, restart NTuneMON and specify RESET=YES to reset the global variables.
- **Communication controller model number**, as defined by the MODEL keyword on the BUILD statement
- **Amount of controller storage in megabytes**, as defined by the MEMSIZE keyword on the BUILD statement
- **Load module name**, as defined by the NEWNAME keyword on the BUILD statement
- **Subarea address in decimal format**, as defined by the SUBAREA keyword on the BUILD statement
- **Serial number of the communication controller**
- **SSP version and release** used to generate NCP
- **Operating system** under which NCP was generated, as defined by the TYP SYS keyword on the BUILD statement
- **NCP version and release**, as defined by the VERSION keyword on the BUILD statement
- **NCP product ID**
- **Operating mode of the communication controller**
- **Usage tiers**, as defined by the USGTIER keyword on the BUILD statement; and, only if a 3746 model 900 is included, CSS tier, as defined by the CSSTIER keyword on the BUILD statement
- **Method used to load NCP**. This field might contain one of the following values:

LOADED OVER CHANNEL

NCP was loaded over a channel from VTAM.

LINK LOADED NCP

NCP was loaded over a link from VTAM.

VTAM LOADED FROM DISK

NCP was loaded from a disk; the load was initiated by the VTAM operator.

DISK LOADED NOT VTAM

NCP was loaded from a disk; the load was not initiated by the VTAM operator.

3745 HARDWARE INFO

MICROCODE EC

Maintenance and operator subsystem (MOSS) microcode engineering change (EC) level.

FIX

Microcode fix level.

CDS Update

Date of the last CDS update.

3746 M900 INFORMATION

S/N

Serial number of the 3746 Model 900. If no 3746 Model 900 is attached, this field displays "No M900".

SNI INFORMATION

This section of the panel provides information on the use of SNA network interconnection (SNI) resources. Press F4=SNI(HSCBs) for more details on SNI resources.

SNI NETWORKS

Number of SNI networks.

HSCBS IN USE

Number and percentage of half-session control blocks (NIX/NLX pairs) in use for all networks, based on the HSBPOOL keyword on the BUILD statement. Percentage is displayed only for NCP V6R2 or later releases.

NATIVE NETID

Network identifier of the network the NCP resides in, as defined by the NETID keyword on the BUILD statement.

BUFFER POOL INFORMATION

If the maximum in-use threshold is met or exceeded, the control block name is highlighted in reverse-video red. If the current in-use threshold is met or exceeded, both the control block name and the percentage figure are highlighted in reverse-video red.

For details on NCP control block pools and tables, press F8=CBPOOLS or use the CB or CBPOOLS fast-path command to display the ATUCB Control Block Pools/Tables panel, as shown on page 4-17.

For details on the buffer pool, use the BP or BUFPOOL fast-path command to display the ATUBP NCP Buffer Pool panel, as shown on page 4-4.

BUFFERS

Percentage of NCP buffers in use. This figure equals (number of buffers currently in use) / (total number of buffers) * 100. The total number of buffers depends on the amount of NCP storage (the MEMSIZE keyword on the BUILD statement), the NCP load module size, and the NCP buffer size (the BFRS keyword on the BUILD statement).

BPOOL

Percentage of the boundary pool in use. This value is used to regulate PIUs sent to the NCP peripheral node. BPOOL is a counter independent from the buffer pool. Each NCP has one BPOOL counter.

The BPOOL counter is initialized to 50% of the number of buffers above the slowdown threshold. This is the maximum number of buffers that can be used at the NCP peripheral node. All buffers above slowdown can be non-switched. No buffers are allocated to BPOOL.

DYNPOOL

Amount of the buffer pool available for dynamic control block allocation as defined by the *percent_of_buffers* suboperand of the DYNPOOL keyword on the BUILD statement.

Additional Control Blocks

Beginning with NTuneMON V2R6, the following control blocks are no longer shown on this panel but are still shown on the ATUCB panel: BSB, LNB, LND, LTX, LUB, LUX, NNT, NSC, NSX, NUMHSAS, PUDR, PUDR AV, and VVT.

Message area

The field below the buffer pool information might display one of the following messages:

RWI LOW

The reset window indicator (RWI) is on for low-priority sessions.

RWI MEDIUM

The RWI is on for medium-priority sessions.

RWI HIGH

The RWI is on for high-priority sessions.

BPOOL FULL

The boundary pool is full; the pacing response is withheld.

VR INFORMATION

This section of the panel provides information on virtual routes in warning or alert status. The fields in this section remain blank if there are no virtual routes in alert or warning status.

The number of entries in the virtual route pool is defined by the VRPOOL keyword on the BUILD statement. Virtual route window sizes are defined by the VRPWS*nm* keyword on the NCP PATH statement and can also be defined on the VTAM PATH statement.

Press F2=VRs or use the VR fast-path command to display the ATUVR Virtual Route panel, which provides more details on virtual routes. See "ATUVR Virtual Route Panel" on page 4-334 for more information.

ACTIVE/MAX

Number of active virtual routes and total number of virtual routes, as defined by the VRPOOL keyword on the BUILD statement.

ALARM/WARN

Number of virtual routes in alert (ALARM) or warning (WARN) status.

An alert (if specified) is issued when:

- The virtual route status (STATE) indicates congestion (BLOCKED), or an unusual state.
- The inbound virtual route PIU pool queue (RCVDQ) exceeds the threshold (LIMIT).

ATUSS Summary Status Panel

A warning is issued when:

- The current (CUR) virtual route window size reaches the maximum (MAX) virtual route window size.
- The current (CUR) virtual route window size reaches the minimum (MIN) virtual route window size.
- The size of the inbound virtual route PIU pool queue (RCVDQ) is greater than zero.

NTuneMON does not issue a generic alert for a warning.

USER ALARM

Alarm threshold for the virtual route inbound PIU count. You can enter a value in this field to change the alarm threshold. NTuneMON issues a generic alert (if specified) when the number of inbound PIUs for a virtual route reaches this percentage of the virtual route inbound queue size limit. (The queue size limit is determined internally by NCP.)

VRTP

Virtual route number and transmission priority.

NETWORK

Network name.

SUBAREA

Subarea address of the other end of the virtual route.

CUR

Current virtual route window size.

MAX

Maximum virtual route window size.

MIN

Minimum virtual route window size.

RCVDQ

Virtual route inbound PIU count. If the value in this field reaches the VR ALARM, the field is highlighted in reverse-video red. If the value has not reached the VR ALARM, but is greater than zero, the field is highlighted in reverse-video pink.

XMTQ

Virtual route outbound PIU count. If the outbound virtual route PIU pool count is non-zero, this field is highlighted in reverse-video red.

VR STATE

Virtual route state (ACTIVE, INACTIVE, INTERNAL, BLOCKED, DISCARD, RWI, CWRI, WPR). For more information on these states, see "ATUVR Virtual Route Panel" on page 4-334.

TG INFORMATION

This section of the panel provides information on transmission groups in warning or alert status. The fields in this section remain blank if there are no transmission groups in alert or warning status.

The values in these fields (except NETWORK and SUBAREA) are defined by the ER*n* keyword on the PATH statement.

For details on transmission groups, press the alternate F5=TGs or use the TG fast-path command to display the ATUTG Transmission Group panel, as shown on page 4-294.

ACTIVE/MAX

Number of active transmission groups and maximum number of transmission groups. A (—) is displayed in the ACTIVE field if the maximum (MAX) number of transmission groups is greater than or equal to the maximum number of transmission groups NTuneMON is to analyze (STOP).

ALARM/WARN

Number of transmission groups in alert or warning status. A warning is issued if the size of the outbound queue is greater than zero. An alert is issued (if specified) when the threshold is exceeded. NTuneMON does not issue a generic alert for a warning. This field can equal STOP HIT if the value for ACTIVE MAX is greater than or equal to STOP.

ALARM

User alarm threshold for transmission group queue size. You can enter a value in this field to change the alarm threshold. NTuneMON issues a generic alert (if specified) when the total size of the PIUs on any outbound queue reaches this percentage of the threshold defined by the ER n keyword on the PATH statement.

STOP

Maximum number of transmission groups that NTuneMON is to analyze. You can enter a value in this field to change the maximum number. NTuneMON does not analyze transmission groups when the number of transmission groups defined reaches this value, which improves NTuneMON performance.

TGN

Transmission group number.

NETWORK

Network address.

SUBAREA

Address of the adjacent subarea.

The following fields show the number of bytes in the outbound queues. If the value in any of these fields reaches the threshold set by ALARM, the field is highlighted in reverse-video pink.

LOW

Total size of low-priority PIUs.

MED

Total size of medium-priority PIUs.

HIGH

Total size of high-priority PIUs.

TOTAL

Total size of all PIUs.

PF Keys

PF Key Selection Number 1

These are the default PF keys for this panel.

F1=HELP

Displays online help for this panel.

F2=VRs

Displays the ATUVR Virtual Route panel, as shown on page 4-334, which provides information on active virtual routes.

F3=RETURN

Returns to the previous NTuneMON panel.

F4=SNI (HSCBs)

Displays the ATUNG HSCBs and GWNAUs panel (for NCP V6R2 or later releases) as shown on page 4-195, or the ATUNN HSCBs (Networks and HSCB Counts) panel (for earlier NCP releases) as shown on page 4-201, that provide information on half-session control blocks (HSCBs) and gateway network addressable units (GWNAUs).

F5=ADAPTERS

Displays the ATUSC1 Channel Adapters panel, as shown on page 4-230, which provides information on IBM 3745 channel adapters.

F6=ROLL

Returns to the NetView command line without exiting NTuneMON. To return to NTuneMON from the NetView program, press F6=ROLL or enter **ATUNEMON** on the NetView command line.

F8=CBPOOLS

Displays the ATUCB Control Block Pools/Tables panel, as shown on page 4-17, which provides information on control block pools usage.

F9=NNTs

Displays the ATUNT NCP Network Names Table panel, as shown on page 4-209, which displays network names table entries and use counts.

ENTER=REFRESH

Refreshes the information on this panel.

F10=UTIL

Displays the ATUUT NCP Utilization panel, as shown on page 4-328, which provides information on NCP CCU and buffer use.

F11=ALT-PFKS

Resets some of the PF keys on this panel to perform different functions. These alternate PF keys are shown in Figure 4-80 on page 4-267.

F12=REFRESH SUMMARY

Refreshes the information on this panel.

PA1=EXIT

Exits NTuneMON.

PA2=LOG

Saves the information on this panel to the NetView log.

PF Key Selection Number 2

Figure 4-80 shows the second set of PF keys for this panel. These alternate functions are enabled when you press F11=ALT-PFKS in the first PF key selection. The alternate functions are described following the figure.

```
=> ATUM022 PF keys have been set to selection number 2
PF1=HELP 2=CBPOOLS 3=RETURN 5=TGs 6=ROLL 9=TOKEN-RING 10=HEX
ENTER=REFRESH 11=ALT-PFKs 12=REFRESH SUMMARY PA1=EXIT PA2=LOG
```

Figure 4-80. PF Key Selection Number 2 for the ATUSS Summary Status Panel

F2=CBPOOLS

Displays the ATUCB Control Block Pools/Tables panel, as shown on page 4-17, which provides information on NCP buffer pool use.

F5=TGs

Displays the ATUTG Transmission Group panel, as shown on page 4-294, which provides information on NCP transmission groups.

F9=TOKEN-RING (starting with NCP V5R4)

Displays the ATUTC Token-Ring Adapter List panel, as shown on page 4-278, which provides information on Token-Ring physical lines.

F10=HEX

Displays the ATUDP Hexadecimal Storage Display panel, as shown on page 4-68, which shows the date and time generation control block (DTG).

F11=ALT-PFKS

Resets some of the PF keys on this panel to perform different functions. These alternate PF keys are shown in Figure 4-81.

PF Key Selection Number 3

Figure 4-81 shows the third set of PF keys for this panel. These alternate functions are enabled when you press F11=ALT-PFKS in the second PF key selection. The alternate functions are described following the figure.

```
=> ATUM022 PF keys have been set to selection number 3
PF1=HELP 2=ETHERNET 3=RETURN 4=SDLC 5=FRAME RELAY 6=ROLL 9=IP STATS
ENTER=REFRESH 10=CSS 11=ALT-PFKs 12=REFRESH PA1=EXIT PA2=LOG
```

Figure 4-81. PF Key Selection Number 3 for the ATUSS Summary Status Panel

F2=ETHERNET (NCP V6R1 or later releases)

Displays the ATUEP Ethernet Adapter List panel, as shown on page 4-81, which provides information on Ethernet-type subsystem (ESS) adapters.

F4=SDLC

Displays the ATUFC Physical Line List panel, as shown on page 4-94, which shows a list of all SDLC lines defined to this NCP.

F5=FRAME RELAY (NCP V6R1 or later releases)

Displays the ATUFC Physical Line List panel, as shown on page 4-94, which shows the status of the frame-relay physical lines defined to an NCP.

F9=IP STATS (NCP V6R1 or later releases)

Displays the ATUIS IP Router Statistics Page 1 panel, as shown on page 4-175, to show information on NCP Internet Protocol functions for an NCP.

ATUSS Summary Status Panel

F10=CSS (starting with NCP V6R2)

Displays the ATUSC4 3746 Model 900 Adapters panel, as shown on page 4-237, which provides information on 3746 Model 900 connectivity subsystem (CSS) adapters.

F11=ALT-PFKS

Resets the PF keys on this panel to perform their original functions, as described on page 4-266.

ATUST NCP Function Activation Panel

Basic fast-path commands: ST, SNAP, SNAPTRACE, POLL

Tuning fields: NTRI/FRAME RELAY SNAP TRACE ENABLED, ODLC SNAP TRACE ENABLED, HPR NLP ROUTE SNAP TRACE ENABLED, NPSI SNAP TRACE ENABLED, IP DATAGRAM SNAP TRACE ENABLED, IP ROUTE SNAP TRACE ENABLED, HPR ROUTE SETUP SNAP TRACE ENABLED, NTUNECOL

```

ATUST  A71SOX2  NCP FUNCTION ACTIVATION  NTuneMON V2R2  11:34

NTRI / FRAME-RELAY
SNAP TRACE  ENABLED = N/A
LAST ENTRY ADDR = N/A

ODLC SNAP TRACE  ENABLED = N/A
LAST ENTRY ADDR = N/A

HPR NLP ROUTE
SNAP TRACE  ENABLED = N/A
LAST ENTRY ADDR = N/A

NPSI
SNAP TRACE  ENABLED = YES
SNAP TRACE ADDR = 164494

IP DATAGRAM SNAP TRACE  ENABLED = N/A
LAST ENTRY ADDR = N/A

IP ROUTE SNAP TRACE  ENABLED = N/A
LAST ENTRY ADDR = N/A

HPR ROUTE SETUP
SNAP TRACE  ENABLED = N/A
LAST ENTRY ADDR = N/A

POLLING COUNT  NTUNECOL = NO

=>
F1=HELP  F3=RETURN  F6=ROLL  F10=HEX  F12=REFRESH  PA1=EXIT  PA2=LOG
    
```

Figure 4-82. ATUST NCP Function Activation Panel

Description

The ATUST NCP Function Activation panel is available for NCP V5R4 or later releases. It displays information about snap traces for NTRI, frame-relay, connectivity subsystem (CSS), NPSI, HPR resources, and IP resources. For more information about the snap traces, refer to the *NCP, SSP, and EP Diagnosis Guide*.

This panel also displays the NTUNECOL keyword. This keyword indicates whether or not NCP is collecting NTuneMON-specific counters.

To display this panel:

- From the ATUSC4 3746 Model 900 Adapters panel, as shown on page 4-237, press F11.
- From the ATUTC Token-Ring Adapter List panel, as shown on page 4-278, press F11.
- From the ATUIS IP Router Statistics Page 1 panel, as shown on page 4-175, press F11.
- From the ATUIX IP Router Statistics Page 2 panel, as shown on page 4-180, press F11.

Fields

NCP name (second field on panel)

Name of the NCP that is currently displayed.

NTRI/FRAME RELAY SNAP TRACE ENABLED

(starting with NCP V5R4 for NTRI; NCP V6R1 or later releases for frame relay)

YES or NO to indicate whether snap trace is enabled for NTRI and frame-relay resources, as defined by the NCPTRACE keyword on the BUILD statement. Token-Ring or frame-relay resources must be defined in the generation to enable this snap trace. If they are not defined, N/A is displayed in this field.

This snap trace provides diagnostic information for NTRI and frame-relay resources by tracing the flow during the execution of each module.

Note: Use the trace when you have an abend, an endless loop, or a performance problem related to NTRI or frame-relay resources, but only at the request of your IBM support representative. The trace might degrade NCP performance.

LAST ENTRY ADDR

This is the last entry in the hex display of the snap trace table for NTRI and Token-Ring resources.

ODLC SNAP TRACE ENABLED (starting with NCP V6R2)

YES or NO to indicate whether snap trace is enabled for 3746 Model 900 resources. To enable this snap trace, a 3745 CSS adapter must be installed and defined in the generation. If ODLIC resources are not defined, this field displays N/A.

This snap trace provides diagnostic information for 3746 Model 900 resources by tracing the main 3746 Model 900 interface control blocks. This is a global trace for four types of interfaces: physical line, target processor, controller bus processor, and trace.

LAST ENTRY ADDR

This is the last entry in the hex display of the snap trace table for ODLIC resources.

HPR NLP ROUTE SNAP TRACE ENABLED (starting with NCP V7R4)

YES or NO to indicate whether snap trace is enabled for HPR NLP route, as defined by the HPRSNAP keyword on the BUILD statement. To enable this snap trace, HPR resources must be defined in the generation. If they are not defined, this field displays N/A.

This snap trace provides information on NLPs routed through the NCP.

LAST ENTRY ADDR

This is the last entry in the hex display of the snap trace table for HPR NLP route.

NPSI SNAP TRACE ENABLED (NCP V7R2 or later releases)

YES or NO to indicate whether snap trace is enabled for NPSI X.25 resources, as defined by the X25SNAP keyword on the BUILD statement. To enable this trace, NPSI resources using NPSI V3R7 or later must be defined in the generation. If NPSI is not included, this field displays N/A.

This trace provides diagnostic information for NPSI X.25 resources by tracing the flow during execution of each module.

Note: Use this trace for problems related to NPSI X.25 resources, only at the request of your IBM support representative. The trace might degrade NCP performance.

SNAP TRACE ADDR

This is a pointer to the start of the NPSI snap trace table.

IP DATAGRAM SNAP TRACE ENABLED (starting with NCP V7R1)

YES or NO to indicate whether snap trace is enabled for IP resources, as defined by the datagram suboperand of the IPSNAP keyword on the BUILD statement. To enable this trace, IP resources must be defined in the generation. If they are not defined, this field displays N/A.

This snap trace provides diagnostic information for IP resources by tracing datagrams that are being discarded by NCP.

Note: Use the trace when NCP is discarding datagrams, but only at the request of your IBM support representative.

LAST ENTRY ADDR

This is the last entry in the hex display of the snap trace table for IP datagrams.

IP ROUTE SNAP TRACE ENABLED (starting with NCP V7R1)

YES or NO to indicate whether snap trace is enabled for IP routes, as defined by the IPSNAP keyword on the BUILD statement. To enable this trace, IP resources must be defined in the generation. If IP resources are not defined, this field displays N/A.

This snap trace provides diagnostic information for IP resources by tracing IP routing information.

Note: Use the trace when you have problems with IP routing tables, but only at the request of your IBM support representative.

LAST ENTRY ADDR

This is the last entry in the hex display of the snap trace table for an IP route.

HPR ROUTE SETUP SNAP TRACE ENABLED (starting with NCP V7R4)

YES or NO to indicate whether snap trace is enabled for HPR route setup, as defined by the HPRSNAP keyword on the BUILD statement. To enable this trace, HPR resources must be defined in the generation. If they are not defined, this field displays N/A.

This snap trace records the flow of HPR route activation and deactivation information going through the NCP.

LAST ENTRY ADDR

This is the last entry in the hex display of the snap trace table for HPR route setup.

POLLING COUNT NTUNECOL (NCP V7R2 or later releases)

YES or NO to indicate whether NCP is collecting information for NTuneMON, as defined by the NTUNECOL keyword on the BUILD statement. If Network Performance Analyzer (NPA) collection is active in NCP, NTuneMON information is also collected when NTUNECOL=NO. The information collected

ATUST NCP Function Activation Panel

includes poll counts for inboard SDLC lines and stations and poll counts for inboard channels.

Note: Starting NPA collection can degrade performance for sending and receiving data. Start collection only when you need to see the information.

PF Keys

F1=HELP

Displays online help for this panel.

F3=RETURN

Returns to the previous NTuneMON panel.

F5=MODIFY

Available if the operator has tuning authority and NTuneNCP is included. Starts or stops the requested NCP function.

F6=ROLL

Returns to the NetView command line without exiting NTuneMON. To return to NTuneMON from the NetView program, press F6=ROLL or enter **ATUNEMON** on the NetView command line.

F10=HEX

When the cursor is placed under a snap trace, displays the ATUDP Hexadecimal Storage Display panel, as shown on page 4-68, to show the control block associated with that snap trace. When nothing is selected, displays the ATUDP Hexadecimal Storage Display panel, to show a generic control block that has pointers to the specific control blocks associated with each snap trace.

F12=REFRESH

Refreshes the information on this panel.

PA1=EXIT

Exits NTuneMON.

PA2=LOG

Saves the information on this panel to the NetView log.

ATUTA Token-Ring SNA Station List Panel

Basic fast-path commands: None

Tuning fields: None

```

ATUTA A71NT05 Token-Ring SNA Station List 1 NTuneMON V2R1 11:36
DEFAULT VIEW= MAC DUAL= STATUS= ACTIVE TIC= ALL FIND=
MAC Address DSAP MAC Address DSAP MAC Address DSAP
400000041093 04

=>
F1=HELP F2=SUBAREA 3=RETURN F4=BNN IDBLK-IDNUM F5=MAC ADDR F6=ROLL F7=BACK
ENTER-STATION DETAILS F8=FWD F9=ALL TICs F10=HEX F12=REFRESH PA1=EXIT PA2=LOG

```

Figure 4-83. ATUTA Token-Ring SNA Station List Panel

Description

The ATUTA Token-Ring SNA Station List panel, which is available for NCP V5R4 or later releases, displays the Token-Ring SNA logical subarea and peripheral stations on the ring going through one or all TICs.

To display this panel:

- On the ATUTC Token-Ring Adapter List panel, as shown on page 4-278, place the cursor under a TIC address and press F2, F4, or F5.
- From the ATUTC Token-Ring Adapter List panel, as shown on page 4-278, press F9.
- From the first PF key selection of the ATUTP1 Token-Ring TIC Details Page 1 panel, as shown on page 4-310, press F2, F4, F7, F8, or Enter.
- From the first PF key selection of the ATUTP2 Token-Ring TIC Details Page 2 panel, as shown on page 4-319, press F2, F4, F7, F8, or Enter.

See the descriptions of these panels for more information.

The stations displayed on this panel are determined by the value in the STATUS DEFAULT field on the ATUTC Token-Ring Adapter List panel. This value is shown in the STATUS field on this panel. Active stations are shown in yellow, and inactive stations are shown in turquoise.

The information displayed for each station is determined by the values in the VIEW DEFAULT fields on the ATUTC Token-Ring Adapter List panel, as shown on page

ATUTA Token-Ring SNA Station List Panel

4-278. These values are shown in the DEFAULT VIEW and DUAL fields on this panel. These values can be any of the following:

MAC MAC address of the station on the ring, if defined. Otherwise, the field is blank. This field also displays the destination SAP (DSAP) address.
SUB Destination subarea address (subarea stations).
CPNAME Control point name of the type 2.1 physical unit
IDBLK Device type
LINE Name of the logical line
QSTAT Status of the Token-Ring line

You can enter any of these values in the DEFAULT VIEW and DUAL fields or on the command line of this panel to change the information on the panel. After you enter one of these values, press Enter to display the new information. You can also change the information on this panel by pressing F2=SUBAREA, F4=BNN IDBLK-IDNUM, F5=MAC ADDR, or F9=ALL TICs.

Note: Displaying many stations can cause high NetView CPU and storage use.

Fields

NCP name (second field on panel)

Name of the NCP that is currently displayed. You can enter a different NCP name in this field to display information on another NCP.

Station counts

Number of stations displayed for that TIC and status.

DEFAULT VIEW and DUAL

Initially the values in the VIEW DEFAULT and (DUAL) fields on the ATUTC Token-Ring Adapter List panel, as shown on page 4-278. To change the information on this panel, you can enter one of the following for DEFAULT VIEW, DUAL, or both:

SUB Destination subarea address
CPNAME Control point name of the type 2.1 physical unit
IDBLK Device type
LINE Name of the logical line
MAC TIC MAC address of the station on the ring if defined. Otherwise, the field is blank. This field also displays the destination SAP (DSAP) address.
QSTAT Status of the Token-Ring line

The information on this panel is sorted by the value you enter in the first of these two fields.

Note: Displaying many stations on the ATUTA Token-Ring SNA Station List panel can cause high NetView CPU and storage use.

STATUS

Initially the value in the STATUS DEFAULT field on the ATUTC Token-Ring Adapter List panel, as shown on page 4-278. To change the information on this panel, you can type in one of the following for STATUS and then press Enter.

ACTIVE Only active stations.
INACTIVE Only inactive stations.
ALL All active and inactive stations.

Notes:

1. The IDBLK-IDNUMs and CPNAMEs being displayed for inactive stations may not be valid. For example, a station which dialed in with an invalid IDBLK-IDNUM or CPNAME would appear as inactive.
2. Displaying many stations on the ATUTA Token-Ring SNA Station List panel can cause high NetView CPU and storage use.

TIC

Address of the physical line attached to the TIC or ALL if all TICs are displayed. To change the information on this panel, you can type in this field a different line address or ALL (to display all TICs) and press Enter.

FIND

Value in the FOR DIRECT FIND ENTER ONE section on the ATUTC Token-Ring Adapter List panel, as shown on page 4-278.

The remainder of the panel displays information on Token-Ring stations based on the selection criteria in the DEFAULT VIEW, DUAL, STATUS, and TIC fields.

MAC Address

TIC MAC address of the station on the ring if defined. Otherwise this field is blank.

DSAP

The destination SAP address.

Link Stat

Status of the Token-Ring line. The status can be any of the following:

Clearing

The link is being cleared.

Disconed

The link is disconnected.

Disconng

The link is being disconnected.

FRMR Rcv

A frame reject was received.

FRMR Snt

A frame reject was sent.

INOPnPrg

The link is attempting to recover from an error.

LkCLOSED

The link is no longer active. Although the information displayed represents an inactive station, the information may be used to resolve problems with unsuccessful dial-in attempts.

LkOPENED

The link is open for communications.

OPENING

The link is being opened.

TResComp

The test resolve is now complete.

ATUTA Token-Ring SNA Station List Panel

TResPend

NCP is attempting to find an active Token-Ring route to a given destination.

XidRspPn

NCP is waiting for the XID response.

PF Keys

F1=HELP

Displays online help for this panel.

F2=SUBAREA

Lists the subareas with connections through this TIC. Pressing this key changes the value of the DEFAULT VIEW field to SUB.

F3=RETURN

Returns to the previous NTuneMON panel.

F4=BNN IDBLK-IDNUM

Lists the IDBLK-IDNUM for each station going through this TIC. Press this key to change the value of the DEFAULT VIEW field to IDBLK.

F5=MAC ADDR

Lists the MAC address for each station going through this TIC. Press this key to change the value of the DEFAULT VIEW field to MAC.

F6=ROLL

Returns to the NetView command line without exiting NTuneMON. To return to NTuneMON from the NetView program, press F6=ROLL or enter **ATUNEMON** on the NetView command line.

F7=BACK

Scrolls the panel data backward one screen.

ENTER=STATION DETAILS

Displays the ATUTL Token-Ring SNA Station panel, as shown on page 4-301, to show detailed information on a specific Token-Ring SNA logical station. Place the cursor under the address of a station and press Enter.

F8=FWD

Scrolls the panel data forward one screen.

F9=ALL TICs

Displays information on the stations going through all TICs. The stations displayed are determined by the value in the STATUS field. The information displayed for each station is determined by the values in the DEFAULT VIEW and DUAL fields. Pressing this key changes the value of the TIC field on this panel to ALL.

F10=HEX

Displays the ATUDP Hexadecimal Storage Display panel, as shown on page 4-68, to show one of the following, depending on what is displayed in this panel:

- The common physical unit block (CUB) for IDBLK-IDNUMs
- The line control block (LKB) for LINES
- The logical link control block (LLB) for CPNAMEs, MACs, and SUBAREAs for a type 1 or type 2 TIC

ATUTA Token-Ring SNA Station List Panel

- The Token-Ring logical station block extension (TSB) for CPNAMEs, MACs, and SUBAREAs for a type 3 TIC

Place the cursor under the station you want to view and press F10.

F12=REFRESH

Refreshes the information on this panel.

PA1=EXIT

Exits NTuneMON.

PA2=LOG

Saves the information on this panel to the NetView log.

ATUTC Token-Ring Adapter List Panel

Basic fast-path commands: TC, TIC, TR, TOKENRING, NTRI
 Tuning fields: None

```

ATUTC A71TEST Token-Ring Adapter List NTuneMON V2R4 14:16
Total Logical Lines Active= 9 Total Defined= 213 User Alarm= 80
PORT LINE MAC LOGICAL LINES
ADD ADDR ADDRESS ACTIVE TOTAL T/R MXTSL RCVBF TYPE TIC STATUS
-----
ANY - - - 0 100 - - - - - -
88 1088 400000711088 100% 5 5 16M 4096 8192 ANY TIC2 INACTIVE
89 1089 400000711089 100% 4 4 16M 4096 8192 ANY TIC2 INACTIVE
ANY - - - 0 100 - - - - - -
76 2144 400000712144 0% 0 4 16M 4096 - ANY TIC3 INACTIVE
- - - - - - - - - - - -
- - - - - - - - - - - -
- - - - - - - - - - - -
- - - - - - - - - - - -
- - - - - - - - - - - -
-----
| FOR DIRECT FIND ENTER ONE: | STATUS DEFAULT | VIEW DEFAULT |
| XID IDBLK-IDNUM= | ACTIVE INACTIVE | MAC SUB CPNAME |
| T/R MAC ADDRESS= | ALL (ACT/INACT) | IDBLK LINE |
| PU-T2.1 CPNAME = | | (DUAL) |
| NCP LINE NAME = | STATUS= ACTIVE | MAC |
-----
=>
F1=HELP F2=SUBAREA F3=RETURN 4=BNN IDBLK-IDNUM F5=MAC ADDR F6=ROLL F7=BACK
ENTER=PHYSICAL TIC F8=FWD F9=ALL TICS F10=HEX F11=FUNC F12=REFRESH PA2=LOG
    
```

Figure 4-84. ATUTC Token-Ring Adapter List Panel

Description

The ATUTC Token-Ring Adapter List panel, which is available for NCP V5R4 or later releases, provides detailed information on the Token-Ring physical lines defined to an NCP and the associated TICs and logical lines. This panel is also the entry point to the NTuneMON support for Token-Ring resources. See Figure 1-8 on page 1-13 for an overview of the panel-to-panel flow within the Token-Ring-related panels.

Note: Analyzing Token-Ring lines can cause high NetView CPU and storage use.

To display this panel:

- From the second PF key selection on the ATUNP NCP Selection panel, as shown on page 4-204, press F9.
- From the first PF key selection on the ATUCD CDS NCP Selection panel, as shown on page 4-27, press F9.
- From the second PF key selection on the ATUNW NCP Wide Selection panel, as shown on page 4-212, press F9.
- From the second PF key selection on the ATUSS Summary Status panel, as shown on page 4-260, press F9.
- From the ATUSC1 Channel Adapters panel, as shown on page 4-230, press F9.
- From the ATUSC2 Line Adapters Page 1 panel, as shown on page 4-233, press F9.

- From the ATUSC3 Line Adapters Page 2 panel, as shown on page 4-233, press F9.
- On the ATUSC2 Line Adapters Page 1 panel, as shown on page 4-233, place the cursor under the NCP line address of a TRA adapter and press Enter.
- On the ATUSC3 Line Adapters Page 2 panel, as shown on page 4-233, place the cursor under the NCP line address of a TRA adapter and press Enter.
- From the ATUSC4 3746 Model 900 Adapters panel, as shown on page 4-237, press F9.

Fields

NCP name (second field on panel)

Name of the NCP that is currently displayed. You can enter a different NCP name in this field to display information on another NCP.

Total Logical Lines Active

Number of active Token-Ring logical lines, excluding NTRI frame handler logical lines. This number is displayed in reverse-video red when the percentage of this count against the total defined reaches the user alarm threshold.

Total Defined

Total number of Token-Ring logical lines in the NCP. The total includes lines defined explicitly and lines defined automatically by the AUTOGEN keyword on the GROUP statement and the AUTOCOPY keyword on the LINE statement. The total excludes NTRI frame handler logical lines.

User Alarm

Alarm threshold for logical line use. You can enter a value in this field to change the alarm threshold. NTuneMON issues a generic alert (if specified) when this percentage of the logical lines associated with any particular TIC is in use, or when this percentage of the logical lines that can be used by any TIC (ANY in the PORT ADD column) is in use.

Counts are not highlighted for subareas because these lines are predefined and dedicated. Dial-ins for ANY and BNN connections can be rejected if there are no more free lines.

The following columns on this panel show information for each TIC.

PORT ADD

Port address, as defined by the PORTADD keyword on the LINE statement.

A port address of ANY indicates lines that are not reserved for a particular TIC (see Figure 4-84 on page 4-278). These lines are defined with PHYPORT=NONE or PHYSRSC=NONE on the GROUP statement. Lines that can be used by any type 1 or type 2 TIC are shown at the top of the list. Lines that can be used by any type 3 TIC are shown separately below all type 1 and type 2 TICs.

LINE ADDR

Line address, as defined by the ADDRESS keyword on the LINE statement for the physical line.

MAC ADDRESS

MAC address of the TIC (the address used on the LAN for this TIC), as defined by the LOCADD keyword on the LINE statement for the physical line. Displayed in reverse-video red if the TIC is inactive.

LOGICAL LINES ACTIVE and LOGICAL LINES TOTAL

Percentage and number of logical lines currently active through the TIC and the total number of logical lines defined in the NCP generation for this TIC, excluding NTRI frame handler logical lines. An active line is a line whose connection is active or recovering.

For the rows with port address ANY, these fields show the number and percentage of unreserved logical lines currently in use by any TIC and the total number of unreserved logical lines defined.

Notes:

1. For type 1 and type 2 TICs, logical subarea lines are always included in the active count, whether they are active or not.
2. The active count for a specific TIC can be greater than the total count for that TIC because active unreserved logical lines are included in the active count of the TIC through which they are active but are not included in that TIC's total count.
3. When VTAM initiates a dial-out connection for a particular TIC, the user might have chosen to "borrow" a logical line defined for another TIC. Because of this,
 - The percentage active for a type 1 or type 2 TIC might exceed 100%.
 - The number of logical lines defined (TOTAL) increases for a type 3 TIC using a borrowed logical line and decreases for the TIC from which the line was borrowed.
4. PHYPORT can be coded for NTRI peripheral logical GROUPS and, starting with NCP V7R8, for 3746 Model 900 Token-Ring peripheral logical GROUPS. Any **inactive** Token-Ring logical lines with PHYPORT=*number* coded will be counted in the LOGICAL LINES TOTAL count for the first physical whose PORTADD is *number* if more than one physical has a PORTADD equal to *number*. Once the inactive PHYPORT=*number* logical is active, it will be counted in the LOGICAL LINES TOTAL count for the physical over which it is active.

T/R

Token-Ring speed: 4 or 16 megabytes per second.

MAXTSL

Maximum outbound PIU size, as defined by the MAXTSL keyword on the LINE statement for the physical line. The maximum frame size is 36 bytes larger than this value. This value limits the maximum amount of TIC buffer space used to store outbound frames.

A type 2 or type 3 TIC can store two outbound frames at the same time. Most of the remaining storage is used for receiving frames. Because these TICs have 64K of storage, a much larger MAXTSL is normally recommended. For these TICs, this field is highlighted in reverse-video pink if MAXTSL is smaller than is normally recommended. If this happens, you might want to increase MAXTSL to improve performance the next time you generate your NCP.

Note: When defining frame size, be sure to consider the characteristics of the bridges and destination PU attached to the line. For more information on Token-Ring frame sizes, see "ATUTL Token-Ring SNA Station Panel" on page 4-301.

RCVBF (type 1 or type 2 TIC)

Maximum inbound frame size, as defined by the RCVBUFC keyword on the LINE statement for the physical line.

The TIC might need to store more than one frame at a time. It is recommended that the RCVBUFC value be at least twice the size of the largest frames the TIC will receive. For a type 2 TIC, this field is highlighted in reverse-video green if RCVBUFC is smaller than is normally recommended. If this happens, you may want to increase RCVBUFC to improve performance the next time you generate your NCP.

TYPE

Type of station supported by this TIC as defined by the ECLTYPE keyword on the GROUP statement: INN (subarea), BNN (peripheral), or ANY (both). For a type 3 TIC, BNN is displayed as ANY.

TIC

TIC type: TIC1, TIC2, or TIC3.

STATUS

Status of the physical line. This can be any of the following:

PEND ACTLINK	An activate link command (ACTLINK) is in progress.
ACTIVE	An ACTLINK has been processed, and the line is active.
PEND DACTLNK	A deactivate link command (DACTLINK) is in progress.
INACTIVE	A DACTLINK has been processed, and the line is inactive.
FORCE DEACT	The line has been forced into deactivation. (A force deactivate command was issued from VTAM.)
PEND ANS	Line quiescence is pending due to automatic network shutdown (ANS).

For a type 1 or type 2 TIC, if the line is inactive and an error has occurred, one of the following error messages is displayed in reverse-video red. (Refer to the *Token-Ring Network Problem Determination Guide* for more information on these errors.)

SIGNAL LOSS	A loss of the received signal was detected.
HARD ERROR	The beaconing timeout was exceeded.
SOFT ERROR	This TIC has transmitted a soft error report MAC frame.
XMIT BEACON	This adapter is transmitting beacon frames.
LOBE WIRE	An open or short circuit was detected in the lobe data path and the TIC was closed.
AUTO REMOVAL	A TIC hardware error was detected and the TIC was closed.
REMOVED	This TIC received a remove MAC frame and was closed. This can be caused by a LAN managing program, such as the IBM LAN Network Manager, issuing a remove adapter command.
RING RECOVERY	The Token-Ring is beaconing and attempting to recover.

FOR DIRECT FIND ENTER ONE

You can enter a value in one of the following fields to find information on a specific TIC without searching through all resources. NTuneMON displays the ATUTA Token-Ring SNA Station List panel with information on the TIC you specified.

XID IDBLK-IDNUM

Device type and identification number, as defined on the VTAM switched major node. IDBLK is up to 3 hexadecimal characters; IDNUM is up to 5 hexadecimal characters. You can type a dash (–) to separate the two values.

T/R MAC ADDRESS

TIC MAC address. This value is the 12-character hexadecimal address defined by the LOCADD keyword on the LINE statement for the physical line.

PU-T2.1 CPNAME

Control point name of the type 2.1 physical unit. This value is an alphanumeric string up to 8 characters long.

NCP LINE NAME

Name of the logical line, as defined explicitly on a LINE statement or automatically by the AUTOGEN keyword on the GROUP statement or the AUTOCOPY keyword on the LINE statement. This value is an alphanumeric string up to 8 characters long.

Note: Displaying many stations on the ATUTA Token-Ring SNA Station List panel can cause high NetView CPU and storage use.

STATUS DEFAULT

You can enter a value in this field to determine which stations are displayed on the ATUTA Token-Ring SNA Station List panel, as shown on page 4-273, which shows information on the stations going through one or all TICs.

ACTIVE	Only active stations.
INACTIVE	Only inactive stations.
ALL	All active and inactive stations.

Notes:

1. The IDBLK-IDNUMs and CPNAMEs being displayed for inactive stations may not be valid. For example, a station which dialed in with an invalid IDBLK-IDNUM or CPNAME would appear as inactive.
2. Displaying many stations on the ATUTA Token-Ring SNA Station List panel can cause high NetView CPU and storage use.

VIEW DEFAULT and (DUAL)

You can enter one of the following values in one or both of these fields to determine what information is displayed for each station on the ATUTA Token-Ring SNA Station List panel:

SUB	Destination subarea address
CPNAME	Control point name of the type 2.1 physical unit
IDBLK	Device type
LINE	Name of the logical line
QSTAT	Status of the Token-Ring line
MAC	TIC MAC address of the station on the ring if defined. Otherwise, the field is blank. This field also displays the destination SAP (DSAP) address.

The information in the ATUTA Token-Ring SNA Station List panel, as shown on page 4-273, is sorted by the value you enter in the first of these two fields.

Note: Displaying many stations on the ATUTA Token-Ring SNA Station List panel can cause high NetView CPU and storage use.

PF Keys**F1=HELP**

Displays online help for this panel.

F2=SUBAREA

Displays the ATUTA Token-Ring SNA Station List panel, as shown on page 4-273, to show all subareas with connections through a particular TIC. Place the cursor under a TIC address in the PORT ADD column and press F2.

F3=RETURN

Returns to the previous NTuneMON panel.

F4=BNN IDBLK-IDNUM

Displays the ATUTA Token-Ring SNA Station List panel, as shown on page 4-273, to show the IDBLK-IDNUM for all stations going through a particular TIC. Place the cursor under a TIC address in the PORT ADD column and press F4.

F5=MAC ADDR

Displays the ATUTA Token-Ring SNA Station List panel, as shown on page 4-273, to show the MAC addresses for all stations going through a particular TIC. Place the cursor under a TIC address in the PORT ADD column and press F5.

F6=ROLL

Returns to the NetView command line without exiting NTuneMON. To return to NTuneMON from the NetView program, press F6=ROLL or enter **ATUNEMON** on the NetView command line.

F7=BACK

Scrolls the panel data backward one screen.

ENTER=PHYSICAL TIC

Displays one of the following:

- ATUTP1 Token-Ring TIC Details Page 1 panel, as shown on page 4-310, to show detailed information on a particular TIC. Place the cursor under a TIC address in the PORT ADD column and press Enter.

ATUTC Token-Ring Adapter List Panel

- ATUTA Token-Ring SNA Station List panel, as shown on page 4-273, with the information you requested when you enter a value in the FOR DIRECT FIND ENTER ONE field. Place the cursor under the TIC address in the PORT ADD column of the TIC you want to search.

F8=FWD

Scrolls the panel data forward one screen.

F9=ALL TICS

Displays the ATUTA Token-Ring SNA Station List panel, as shown on page 4-273, to show information on the stations going through all TICs. The stations displayed are determined by the value in the STATUS DEFAULT field on this panel. The information displayed for each station is determined by the values in the VIEW DEFAULT and (DUAL) fields on this panel.

F10=HEX

Displays the ATUDP Hexadecimal Storage Display panel, as shown on page 4-68, to show the physical link control block (PLB) for a type 1 or type 2 TIC, or the Token-Ring line block extension (TLB) for a type 3 TIC. Place the cursor under the TIC you want to view and press F10.

F11=FUNC

Displays the ATUST NCP Function Activation panel, as shown on page 4-269, to show snap trace information for NTRI, ODLC, and IP resources. Use the snap trace under the direction of your IBM service representative.

F12=REFRESH

Refreshes the information on this panel.

PA1=EXIT

Exits NTuneMON.

PA2=LOG

Saves the information on this panel to the NetView log.

ATUTD NTRI Frame Handlers Logical Line Details Panel

Basic fast-path commands: None

Tuning fields: COMRATE, MAC Address, LMI

```

ATUTD A71NT06 NTRI Frame Handlers Logical Line Details NTuneMON V2R1 16:01
Route through 0 Bridges LLC Status: Link Opened

Elapsed Time
0
BDGLF = -
T1LOC = 1.5
T1REM = 2.5

-----
Line Name = A71FTLLN
PHYPORT = 1
COMRATE = 1
DATBLK = 2048
MAXFRAME = 8000
Max DLCI = 991
MAC Address = 400000041088

Local Management Interface DLCI 0
LMI = ANSI PU Status = ACTIVE
Network and User Side
LVL3 Discards = 0
LVL5 Discards = 0
User Network
N391 = 6 N392 = 3/0
N392 = 3/0 N393 = 4
N393 = 4 N393 = 4
T391 = 10 Sec T392 = 15 Sec
Send = 16(10) Send = 16(10)
Rcvd = 16(10) Rcvd = 17(11)

-----
Frame Statistics
Max Size Frame Sent = 1025
Min Size Frame Sent = 25
Number of Frames Sent = 832
Estimated Bytes Sent = -
=> ATUM017 Press F12 to see Traffic or Polling rates
F1=HELP F3=RETURN F4=RESET MIN/MAX F5=MODIFY F6=ROLL F10=HEX
ENTER=DLCIs F12=REFRESH/TRAFFIC RATES PA1=EXIT PA2=LOG
    
```

Figure 4-85. ATUTD NTRI Frame Handlers Logical Line Details Panel

Description

The ATUTD NTRI Frame Handlers Logical Line Details panel, which is available for NCP V7R3 or later releases, displays detailed information on a NTRI frame handler logical line associated with a type 1 or type 2 TIC.

To display this panel:

- On the ATUTF NTRI Frame Handler Logical Lines panel, as shown on page 4-291, place the cursor under a line and press Enter.
- On the ATUFS1 Frame Relay Switching Equipment Page 1 panel, as shown on page 4-127, place the cursor under the LINE ADDR field of a NTRI frame handler logical line and press Enter.

Fields

NCP name (second field on panel)

Name of the NCP that is currently displayed.

Route through *n* bridges

Number of bridges and LAN segments the route goes through.

LAN segment numbers are displayed in boxes, and bridge numbers between NCP and the destination station are displayed below and between the boxes. Both numbers are hexadecimal. If there are no bridges, no boxes are displayed.

ATUTD NTRI Frame Handlers Logical Line Details Panel

The TIC is usually attached to the LAN segment displayed in the leftmost box, and the destination station is usually attached to the LAN segment displayed in the rightmost box.

LLC Status:

Status of the Token-Ring line. The status can be any of the following:

Logical Link Closed The link is no longer active. Although the information displayed represents an inactive station, the information may be used to resolve problems with unsuccessful dial-in attempts.

Test Resolve Pending NCP is attempting to find an active Token-Ring route to a given destination.

Test Resolve Complete The test resolve is now complete.

Link Opened The link is open for communications.

Link Disconnected The link is disconnected.

Elapsed Time

The amount of time that has passed from panel entry until the panel is refreshed or the amount of time that has passed since the statistics were last refreshed.

BDGLF

Largest frame size that all bridges along the route can support. A dash (-) is displayed in this field if there are no bridges in the route (that is, no routing information is present).

T1LOC

Token-Ring (T1) value for stations connected to a local Token Ring, as defined by the LOCALTO keyword on the BUILD statement or the *localt1* suboperand of the T1TIMER keyword on the BUILD statement.

T1LOC is less than or equal to T1REM, as defined by the REMOTTO keyword on the BUILD statement or the *remott1* suboperand of the T1TIMER keyword on the BUILD statement.

T1REM

Token-Ring reply timer (T1) value for stations connected to a remote Token Ring as defined by the REMOTTO keyword on the BUILD statement or the *remott1* suboperand of the T1TIMER keyword on the BUILD statement.

Line Name

Name of this line. This name is the label on the LINE statement.

PHYPORT

Port address of the associated physical line, as defined by the PORTADD keyword on the LINE statement.

COMRATE

Relative transmit priority for this line as defined by the *priority* suboperand of the COMRATE keyword on the LINE statement. *Priority* is multiplied by the value of the DATABLEK keyword on the LINE statement to determine the guaranteed minimum number of bytes that a line can transmit before a different line must be given a transmission opportunity.

DATABLEK

Minimum guaranteed transmission bandwidth (in bytes) that can be allocated to a resource, as defined by the DATABLEK keyword on the physical LINE

statement. The DATABLK keyword is used with the *priority* suboperand of the COMRATE keyword on the physical LINE statement to determine a relative priority among logical lines. The value of *priority* is multiplied by the value of DATABLK to determine the guaranteed minimum number of bytes that a line can transmit before a different line must be given a transmission priority.

MAXFRAME

Maximum frame size, in bytes, for this logical line as defined by the MAXFRAME keyword on the logical LINE statement.

Max DLCI

Maximum DLCI address for this line, as specified by the MAXDLCI keyword.

MAC Address

MAC address of the destination TIC where the line terminates. The last 6 bytes specified for the ADDR keyword on the PU statement are the destination MAC address for the logical line.

Frame Statistics

This section of the panel displays frame information for the NTRI frame handler logical line.

Max Size Frame Sent

Maximum size frame (in bytes) sent over this line since the last time this field was reset by NTuneMON. When you reset this field by pressing F4, NTuneMON automatically refreshes the panel and displays the new traffic rate if it is available. Otherwise, NTuneMON displays a dash (–) until the new traffic rate is available and you press F12 or reenter the panel to display the new rate.

Note: Set the NTUNECOL keyword on the BUILD definition statement to YES to allow the data to be collected and displayed.

Min Size Frame Sent

Minimum size frame (in bytes) sent over this line since the last time this field was reset by NTuneMON. When you reset this field by pressing F4, NTuneMON automatically refreshes the panel and displays the new traffic rate if it is available. Otherwise, NTuneMON displays a dash (–) until the new traffic rate is available and you press F12 or reenter the panel to display the new rate.

Note: Set the NTUNECOL keyword on the BUILD definition statement to YES to allow the data to be collected and displayed.

Number of Frames Sent

Number of frames sent over this line. When this panel is entered, displays the number of frames. When F12 is pressed, displays frames per second (*n/Sec*).

Note: Set the NTUNECOL keyword on the BUILD definition statement to YES to allow the data to be collected and displayed.

Estimated Bytes Sent

Estimated bytes per second (*n/SEC*) sent over this line. The number of bytes are estimated by taking the average of the maximum size frame sent and the minimum size frame sent. To get a more current estimate, press F4 to reset the Max Size Frame Sent and Min Size Frame Sent fields. NTuneMON resets the fields and automatically refreshes the panel. If new traffic rates are

ATUTD NTRI Frame Handlers Logical Line Details Panel

available, they are displayed. Otherwise, a dash (–) is displayed until new traffic rates are available and you press F12 to refresh the traffic rates.

Note: Set the NTUNECOL keyword on the BUILD definition statement to YES to allow the data to be collected and displayed.

Local Management Interface DLCI 0

The following fields show LMI information for the NTRI frame handler logical line.

Message area

The line above the LMI field might display one of the following messages:

Full Status MSG Outstanding

NCP has sent an LMI full status message to the adjacent node and is awaiting a response.

LIV Status MSG Outstanding

NCP has sent an LMI link integrity verification (LIV) status enquiry message to the adjacent node and is awaiting a response.

LMI

LMI standard (CCITT, CCITT-NUI, ANSI, ANSI-NUI, or NO) as defined by the LMI keyword on the PU statement.

PU Status

The status of the LMI PU, which will be one of the following:

INACTIVE	Reset
CONT PND	Contact pending
PENDING	Contact and discontact pending
ACTIVE	Active (normal data)
DISC PND	Discontact pending

Message area

The line below the LMI field displays a message to indicate whether the LMI protocol is being used for the network or user side of the link.

This field may also display “LMI Activation Pending” to indicate that LMI communication over DLCI 0 to the adjacent frame-relay node is still pending. Verify that the LMI parameters at each end of the line are compatible; for example, if the adjacent node uses ANSI-standard LMI protocol, be sure LMI=ANSI is defined for this NCP.

LVL 3 Discards

Number of LMI frames received over DLCI 0 that were discarded by NCP level 3.

LVL 5 Discards

Number of LMI frames discarded by NCP level 5 due to format errors.

Network and User Side

The following fields show values for standard LMI variables for both the user side and the network side of this connection.

N391

Minimum frequency (number of T391 intervals) at which LMI Status Enquiry Full messages are sent over this line to the adjacent node as defined by the SPOLL keyword on the PU statement. This value is displayed only for the user side of the line.

N392 (gen/cur) and N393

LMI error threshold at which NCP determines that communication with the adjacent device has been lost as defined by the `ERRORT` keyword on the `PU` statement. This threshold is reached when `N392` LMI errors occur in `N393` consecutive LMI events. For `N392`, `NTuneMON` shows both the generated value and the current error count.

T391

Interval, in seconds, between transmissions of LMI status enquiry messages as defined by the `t391` suboperand of the `TIMERS` keyword on the `PU` statement. `T391` is used only on the user side of the line.

T392

Interval, in seconds, in which an LMI status enquiry message must be received before the time interval is considered an error interval. Defined by the `t392` suboperand of the `TIMERS` keyword on the `PU` statement. `T392` is used only on the network side of the line.

Send

Current send sequence number for the user and network side of the line, shown in decimal and hexadecimal formats.

Rcvd

Current receive sequence number for the user and network side of the line, shown in decimal and hexadecimal formats.

PF Keys

F1=HELP

Displays online help for this panel.

F3=RETURN

Returns to the previous `NTuneMON` panel.

F4=RESET MIN/MAX

Available when the operator has tuning authority and `NTuneNCP` is included. For more information, refer to Chapter 5, Using the `NTuneNCP` Tuning Feature.

Resets the values of the `Max Size Frame Sent` and `Min Size Frame Sent` fields. After resetting the fields, `NTuneMON` automatically refreshes the panel. If new traffic rates are available, they are displayed. Otherwise, `NTuneMON` displays a dash (-) until new traffic rates are available and you press `F12` or reenter the panel to display the new rates.

F5=MODIFY

Available when the operator has tuning authority and `NTuneNCP` is included. For more information, refer to Chapter 5, Using the `NTuneNCP` Tuning Feature.

Updates the `NCP` tuning parameter with the modified value. If the modification is not valid, the field turns reverse-video pink, and you are prompted to correct the value and resubmit it.

F6=ROLL

Returns to the `NetView` command line without exiting `NTuneMON`. To return to `NTuneMON` from the `NetView` program, press `F6=ROLL` or enter **ATUNEMON** on the `NetView` command line.

F10=HEX

Displays the `ATUDP` Hexadecimal Storage Display panel, as shown on page 4-68, to show the logical link control block (LLB) for this line.

ATUTD NTRI Frame Handlers Logical Line Details Panel

ENTER=DLCIs

Displays the ATUFA Frame Relay Subport List panel, as shown on page 4-88, to show all the FHSPs for this line.

F12=REFRESH/TRAFFIC RATES

Refreshes the information on this panel and displays the traffic rates.

PA1=EXIT

Exits NTuneMON.

PA2=LOG

Saves the information on this panel to the NetView log.

ATUTF NTRI Frame Handler Logical Lines Panel

Basic fast-path commands: None

Tuning fields: None

```

ATUTF A7INT06 NTRI Frame Handler Logical Lines NTuneMON V2R3 15:58
TIC = ALL NTRI FH Logical Lines Defined = 2 Elapsed Time = 0
Line MAC Max Size Min Size Number of Estimated
Name Address COMRATE Frame Sent Frame Sent Frames Sent Bytes Sent
-----
A71FTLLN 400000041088 1 1025 25 775 -
A71FTBLN 400000041089 1 1025 25 506 -

=> ATUM017 Press F12 to see Traffic or Polling rates
F1=HELP F2=DLCIs F3=RETURN F6=ROLL F7=BACK F8=FORWARD F9=ALL TICs
ENTER=LINE DETAILS F10=HEX F12=REFRESH/TRAFFIC RATES PA1=EXIT PA2=LOG

```

Figure 4-86. ATUTF NTRI Frame Handler Logical Lines Panel

Description

The ATUTF NTRI Frame Handler Logical Lines panel, which is available for NCP V7R3 or later releases, displays information about NTRI frame handler logical lines associated with one or all type 1 or type 2 TICs.

To display this panel: From the second PF key selection on either the ATUTP1 Token-Ring TIC Details Page 1 panel, as shown on page 4-310, or the ATUTP2 Token-Ring TIC Details Page 2 panel, as shown on page 4-319, press F8 or Enter. See the descriptions of the panels for more information.

Fields

NCP name (second field on panel)

Name of the NCP that is currently displayed.

TIC

Address of the physical line attached to the TIC or ALL if all TICs are displayed.

NTRI FH Logical Lines Defined

Total of NTRI frame handler logical lines associated with this TIC or all TICs.

Elapsed Time

The amount of time that has passed from panel entry until the panel is refreshed or the amount of time that has passed since the statistics were last refreshed.

Line Name

Name of the line. This name is the label on the LINE statement.

ATUTF NTRI Frame Handler Logical Lines Panel

MAC Address

MAC address of the destination TIC where the line terminates.

COMRATE

Relative transmit priority for this line as defined by the *priority* suboperand of the COMRATE keyword on the logical LINE statement. *Priority* is multiplied by the value of the DATBLK keyword on the LINE statement to determine the guaranteed minimum number of bytes that a line can transmit before a different logical line must be given a transmission opportunity.

Max Size Frame Sent

Maximum size frame (in bytes) sent over this line.

Note: Set the NTUNECOL keyword on the BUILD definition statement to YES to allow the data to be collected and displayed.

Min Size Frame Sent

Minimum size frame (in bytes) sent over this line.

Note: Set the NTUNECOL keyword on the BUILD definition statement to YES to allow the data to be collected and displayed.

Number of Frames Sent

Number of frames sent over this line. When this panel is entered, displays the number of frames. When F12 is pressed, displays frames per second (*n/Sec*).

Note: Set the NTUNECOL keyword on the BUILD definition statement to YES to allow the data to be collected and displayed.

Estimated Bytes Sent

Estimated bytes per second (*n/SEC*) sent over this line. The number of bytes is estimated by taking the average of the maximum size frame sent and the minimum size frame sent.

Note: Set the NTUNECOL keyword on the BUILD definition statement to YES to allow the data to be collected and displayed.

PF Keys

F1=HELP

Displays online help for this panel.

F2=DLCIs

Displays the ATUFA Frame Relay Subport List panel, as shown on page 4-88, to show the FHSPs defined for a NTRI frame handler line. Place the cursor under a line and press F2.

F3=RETURN

Returns to the previous NTuneMON panel.

F6=ROLL

Returns to the NetView command line without exiting NTuneMON. To return to NTuneMON from the NetView program, press F6=ROLL or enter **ATUNEMON** on the NetView command line.

F7=BACK

Scrolls the panel data backward one screen.

F8=FORWARD

Scrolls the panel data forward one screen.

ATUTF NTRI Frame Handler Logical Lines Panel

F9=ALL TICs

Displays the NTRI frame handler logical lines associated with all TICs.

ENTER=LINE DETAILS

Displays the ATUTD NTRI Frame Handlers Logical Line Details panel, as shown on page 4-285, to show detailed information on a NTRI frame handler logical line. Place the cursor under a line and press Enter.

F10=HEX

Displays the ATUDP Hexadecimal Storage Display panel, as shown on page 4-68, to show the logical link control block (LLB) for a line. Place the cursor under a line and press F10.

F12=REFRESH/TRAFFIC RATES

Refreshes the information on this panel and displays traffic rates.

PA1=EXIT

Exits NTuneMON.

PA2=LOG

Saves the information on this panel to the NetView log.

ATUTG Transmission Group Panel

Basic fast-path commands: TG, TGS
 Tuning fields: None

ATUTG	A04D1	Transmission Group			ACT/MAX = 2/23		NTuneMON	V2R6 13:07
NETWORK	SUBAREA	TG	LOW	MEDIUM	HIGH	TOTAL	STATE/TYPE	
NETA	2	1	256	-	-	256	Operative	
			204800	-	-	409600	CHANNEL	
NETA	71	1	0	0	0	0	Operative	
			5000	5000	5000	20000	INN LINK	

=>
 F1=HLP F2=TIME F3=RTN F6=ROLL F7=BCK F8=FWD F9=ALL F10=HEX F12=RFSH ENTER=MLTG

Figure 4-87. ATUTG Transmission Group Panel

Description

The ATUTG Transmission Group panel displays information on NCP transmission groups. When you first enter this panel, it displays only operative transmission groups. To display all operative and inoperative transmission groups, press F9=ALL. Figure 4-87 shows all operative and inoperative transmission groups.

To display this panel:

- From the second PF key selection of the ATUNP NCP Selection panel, as shown on page 4-204, press F5.
- From the first PF key selection of the ATUCD CDS NCP Selection panel, as shown on page 4-27, press F5.
- From the second PF key selection of the ATUNW NCP Wide Selection panel, as shown on page 4-212, press F5.
- From the second PF key selection of the ATUSS Summary Status panel, as shown on page 4-260, press F5.

Fields

NCP name (second field on panel)

Name of the NCP that is currently displayed. You can enter a different NCP name in this field to display information about another NCP.

ACT/MAX TG

Number of currently active transmission groups and maximum number of transmission groups.

NETWORK

Network name. Active defined networks on this panel are displayed in blue. Active dynamic networks are displayed in yellow.

SUBAREA

Adjacent subarea address.

TG

Transmission group number.

Flow-Control Thresholds: The ER*n* keyword on the PATH statement defines flow control thresholds for low-priority, medium-priority, and high-priority PIUs, and for all PIUs. Figure 4-88 shows PIUs of each priority in the outbound queue.

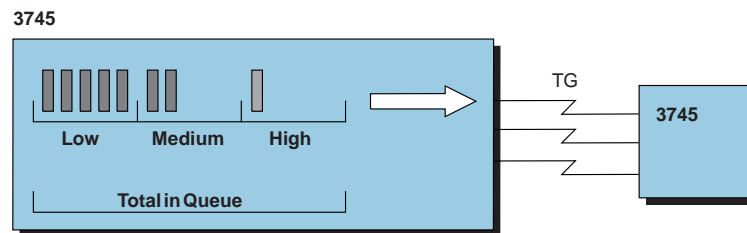

Figure 4-88. PIUs of Different Priorities in the Outbound Queue

When the total size of low-priority, medium-priority, or high-priority PIUs in the outbound queue exceeds the corresponding threshold (minor congestion), NCP decreases the current virtual route window size by one. When this happens, NTuneMON highlights the number of bytes queued and the threshold in reverse video. (Figure 4-87 on page 4-294 shows the number of bytes queued and the low-priority threshold highlighted in the LOW column.)

When the total size of all PIUs in the outbound queue exceeds the total-PIU threshold (major congestion), NCP decreases the current virtual route window size to the minimum. When this happens, NTuneMON highlights the number of bytes queued and the threshold in reverse video.

You can increase any of these thresholds by increasing the corresponding value of the ER*n* keyword on the PATH statement. Make sure NCP has enough storage for the thresholds you define.

When the total size of the PIUs in any outbound queue reaches the threshold set by ALARM for transmission groups on the ATUSS Summary Status panel, the queue size on this panel is highlighted in reverse-video pink and NTuneMON issues a generic alert (if specified).

Note: NTuneMON displays large queue sizes in kilobytes (1024 bytes). In this case, the number is followed by the letter K.

LOW

Total size (in bytes) of low-priority PIUs queued and low-priority threshold. The queue size is shown above the threshold value.

ATUTG Transmission Group Panel

MEDIUM

Total size of medium-priority PIUs queued and medium-priority threshold. The queue size is shown above the threshold value.

HIGH

Total size of high-priority PIUs queued and high-priority threshold. The queue size is shown above the threshold value.

TOTAL

Total size of all PIUs queued and threshold for all PIUs. The queue size is shown above the threshold value.

STATE/TYPE

Transmission group state (OPERATIVE or INOP) and type. The type can be any of the following:

INN LINK

Subarea link

CHANNEL

Channel link

ESCON

Active ESCON link

UNKNOWN

The TG has never been operative and the type is not known. NCP provides this information once the TG is operative.

Note: When the state of the TG is INOP, the last known type is displayed. When the TG is OPERATIVE, the current type is displayed.

Channel Links: Channel transmission groups do not use the thresholds defined by the ER n keyword on the PATH statement. Instead, there is a minor-congestion threshold (8 times the value of the MAXBFRU keyword on the PU statement) and a major-congestion threshold (16 times the value of the MAXBFRU keyword on the PU statement). NTuneMON displays the minor-congestion threshold in the LOW column and the major-congestion threshold in the TOTAL column. See "ATUSC1 Channel Adapters Panel" on page 4-230 for more information on MAXBFRU.

ESCON Links: NTuneMON does not display the current PIU count for ESCON links. Only the thresholds are displayed.

PF Keys

F1=HLP

Displays online help for this panel.

F2=TIME

Displays the ATUVT VR Alert Timer panel, as shown on page 4-338.

F3=RTN

Returns to the previous NTuneMON panel.

F6=ROLL

Returns to the NetView command line without exiting NTuneMON. To return to NTuneMON from the NetView program, press F6=ROLL or enter **ATUNEMON** on the NetView command line.

F7=BCK

Scrolls the panel data backward one screen.

F8=FWD

Scrolls the panel data forward one screen.

F9=ALL

Displays all operative and inoperative transmission groups.

F10=HEX

Displays the ATUDP Hexadecimal Storage Display panel, as shown on page 4-68, to show a transmission group control block (TGB). Place the cursor under the transmission group you want to view and press F10.

F12=RFSH

Refreshes information for all transmission groups from their transmission group control blocks.

ENTER=MLTG

Displays the ATUML Multi-Link Transmission Group panel, as shown on page 4-184, to provide more information about the transmission group and the origin and destination NCPs. This is valid for subarea links (INN LINK) only. Place the cursor under the transmission group you want to view and press Enter.

PA1=EXIT

Exits NTuneMON.

PA2=LOG

Saves the information on this panel to the NetView log.

ATUTI Token-Ring IP Statistics Panel

Basic fast-path commands: None
 Tuning fields: None

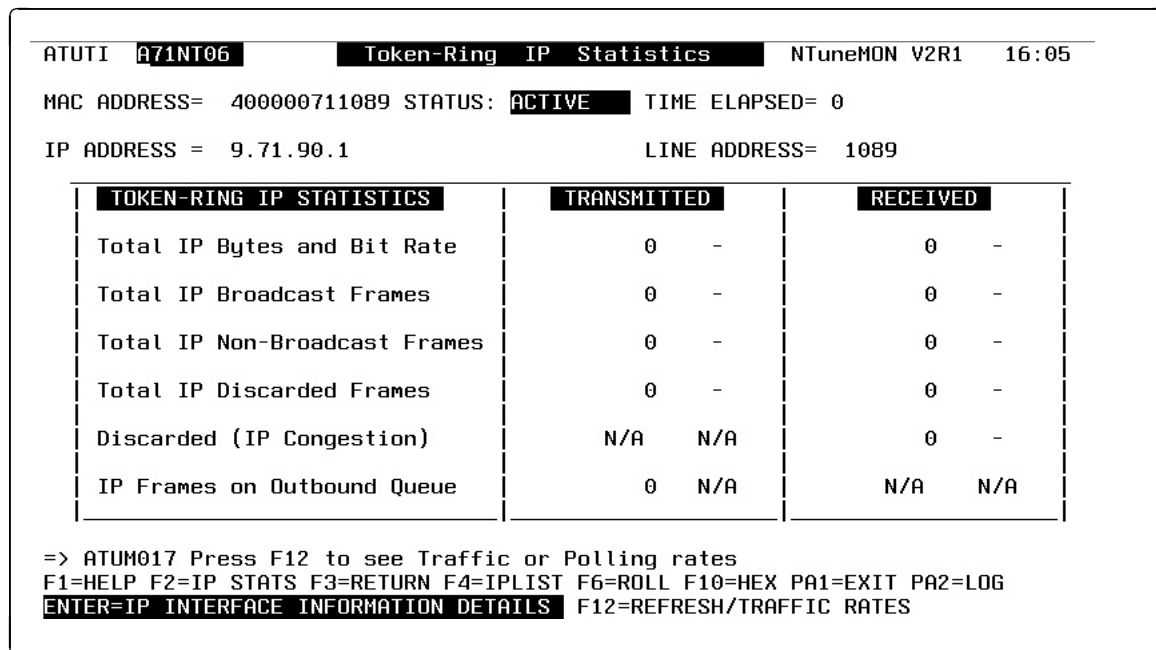

Figure 4-89. ATUTI Token-Ring IP Statistics Panel

Description

The ATUTI Token-Ring IP Statistics panel, which is available for NCP V7R1 or later releases, displays statistics for IP over Token Ring. (If you have defined an internal 3746 Model 900 point-to-point IP connection, it is treated as a Token-Ring interface.)

To display this panel:

- From the second PF key selection of either the ATUTP1 Token-Ring TIC Details Page 1 panel, as shown on page 4-310, or the ATUTP2 Token-Ring TIC Details Page 2 panel, as shown on page 4-319, press F2.
- From the ATUID IP Interface Information Detail panel, as shown on page 4-164, press F7.

Fields

NCP name (second field on panel)

Name of the NCP that is currently displayed.

MAC ADDRESS

MAC address of this TIC as defined by the LOCADD keyword on the LINE statement for the physical line.

STATUS

The status of the Token-Ring TIC. Will be one of the following:

ACTIVE An ACTLINK has been processed, and the line is active.

INACTIVE

A DACTLINK has been processed, and the line is inactive.

TIME ELAPSED

Amount of time that has passed since the statistics were last refreshed.

IP ADDRESS

Four-byte internet address of the associated interface as defined by the LADDR keyword on the IPLOCAL statement (or for an internal 3746 Model 900 point-to-point IP connection, on either the IPLOCAL statement or the PU statement).

LINE ADDRESS

Physical line address.

TOKEN-RING IP STATISTICS

The following fields show TRANSMITTED and RECEIVED counts and changes to the TRANSMITTED and RECEIVED rates. If the number of frames since the last refresh is greater than one per second, this value is shown as a number of frames per second (n/S). If the number of frames is less than one per second, the actual number of frames is shown. If information is not available, a dash (-) is displayed.

Total IP Bytes and Bit Rate

Number of bytes transmitted and received, and traffic rate in bits, megabits, or kilobits per second.

Total IP Broadcast Frames

Number of broadcast frames transmitted and received.

Total IP Non-Broadcast Frames

Number of non-broadcast frames transmitted and received.

Total IP Discarded Frames

Number of frames discarded.

Discarded (IP Congestion)

Number of frames discarded due to internet congestion. This information is not applicable (N/A) for the TRANSMITTED columns.

IP Frames on Outbound Queue

Number of frames on the outbound queue. This information is not applicable (N/A) for the TRANSMITTED change rate column or for the RECEIVED columns.

PF Keys

F1=HELP

Displays online help for this panel.

F2=IP STATS

Displays the ATUIS IP Router Statistics Page 1 panel, as shown on page 4-175, to show counters for IP datagrams and ICMP messages.

F3=RETURN

Returns to the previous NTuneMON panel.

F4=IPLIST

Displays the ATUIL IP Interface Information panel, as shown on page 4-169, to show information about an IP interface.

ATUTI Token-Ring IP Statistics Panel

F6=ROLL

Returns to the NetView command line without exiting NTuneMON. To return to NTuneMON from the NetView program, press F6=ROLL or enter **ATUNEMON** on the NetView command line.

F10=HEX

Displays the ATUDP Hexadecimal Storage Display panel, as shown on page 4-68, to show the Ethernet statistical counters (ECT) control block.

PA1=EXIT

Exits NTuneMON.

PA2=LOG

Saves the information on this panel to the NetView log.

ENTER=IP INTERFACE INFORMATION DETAILS

Displays the ATUID IP Interface Information Detail panel, as shown on page 4-164, to show detailed information about an IP interface.

F12=REFRESH/TRAFFIC RATES

Refreshes the information on this panel and displays traffic rates.

ATUTL Token-Ring SNA Station Panel

Basic fast-path commands: None

Tuning fields: T1LOC, T1REM, T2LOC, T2REM, N3GEN, CONGESTION, STATION, #PIUs/BLOCK, DYNWIND(NW,DW,DWC), SSAP, T/R Address, UNIQUE, DSAP, MAXDATA GEN, MAXOUT GEN, BLOCK GEN, PIUCHECK GEN

```

ATUTL A12V7R8 Token-Ring SNA Station A71V7RX NTuneMON V2R6 10:21
Route through 1 Bridges LLC Status: Link Opened BDGLF = 17800
                                         T1LOC = 2.0
                                         T1REM = 5.0
                                         T2LOC = 0.0
                                         T2REM = 0.0
                                         N3GEN = 2
                                         #PIUS/BLOCK = 0
                                         DYNWIND(NW,DW,DWC) = 4 1 0
                                         DESTINATION STATION Subarea Station
                                         IDBLK-IDNUM= - LINE= A12LL89Y
                                         T/R Address= 400000711089 DSAP = 10
                                         UNIQUE = NO
                                         CPNAME = - ACTIVE
                                         TG= 1 SUBAREA= 71 NETID= NETA

|-----| |-----|
| FF1 | - | FF3 |
|-----| |-----|
      2
CONGESTION = NONE STATION = NORMAL
MODE = NORMAL
NCP TOKEN-RING TIC
Line Addr= 1089 TIC2 16M
T/R Addr = 400000121089
SSAP = 10
PHYPORT = 89 ACTIVE

FRAME STATISTICS:   TRANSMIT   RECEIVE   CUR:   GEN:
MAXTSL/RCVBUFC    = 4096 <----> 8192  MAXDATA = 4096  0
Frames Count      = 0001 --><-- 0001  MAXOUT   = 8     8
WW / Outs. Frame ct = 8/-          BLOCK    = 0     0
N3 / I-Frame Rcv ct =              1/0    PIUCHECK = NO   NO

=>
F1=HELP F2=DISG STATION PU F3=RETURN F4=Force Reroute F5=MODIFY F6=ROLL
ENTER-TG DETAILS(SUBA ONLY) F10=HEX F12=REFRESH PA1=EXIT PA2=LOG
    
```

Figure 4-90. ATUTL Token-Ring SNA Station Panel

Description

The ATUTL Token-Ring SNA Station panel, which is available for NCP V5R4 or later releases, displays detailed information on a specific Token-Ring SNA logical station. All Token-Ring SNA logical peripheral stations are switched, whereas all Token-Ring logical subarea stations are leased. Also, there is a one-to-one correspondence of logical line to logical station.

To display this panel: On the ATUTA Token-Ring SNA Station List panel, as shown on page 4-273, place the cursor under a station and press Enter. See the description of that panel for more information.

Fields

NCP name (second field on panel)

Name of the NCP that is currently displayed.

Route through *n* bridges

Number of bridges and LAN segments the route goes through.

LAN segment numbers are displayed in the boxes, and bridge numbers between NCP and the destination station are displayed below and between the boxes. Both numbers are hexadecimal. If there are no bridges, no boxes are displayed.

The TIC is usually attached to the LAN segment displayed in the leftmost box, and the destination station is usually attached to the LAN segment displayed in the rightmost box.

LLC status

Status of the Token-Ring line. The status can be any of the following:

Logical Link Closed The link is no longer active. Although the information displayed represents an inactive station, the information may be used to resolve problems with unsuccessful dial-in attempts.

Test Resolve Pending NCP is attempting to find an active Token-Ring route to a given destination.

Test Resolve Complete The test resolve is now complete.

XID Response Pending NCP is waiting for the XID response.

FRMR Sent A frame reject was sent.

FRMR Received A frame reject was received.

INOP in Progress The link is attempting to recover from an error.

Link Opening The link is being opened.

Link Opened The link is open for communications.

Link Clearing The link is being cleared.

Link Disconnecting The link is being disconnected.

Link Disconnected The link is disconnected.

BDGLF

Largest frame size that all bridges along the route can support. A dash (-) is displayed in this field if there are no bridges in the route (that is, no routing information is present).

T1LOC

Token-Ring (T1) value for stations connected to a local Token Ring as defined by the LOCALTO keyword on the LINE statement or the *localt1* suboperand of the T1TIMER keyword on the LINE statement.

T1LOC is less than or equal to T1REM, as defined by the REMOTTO keyword on the LINE statement or the *remott1* suboperand of the T1TIMER keyword on the LINE statement. Refer to Table 5-1 on page 5-7 for additional information.

T1REM

Token-Ring reply timer (T1) value for stations connected to a remote Token Ring as defined by the REMOTTO keyword on the LINE statement or the *remott1* suboperand of the T1TIMER keyword on the LINE statement.

T2LOC

Timer value for connections over a local Token Ring as defined by the *localt2* suboperand of the T2TIMER keyword on the LINE statement.

T2REM

Timer value for connections over a remote (T2REM) Token Ring as defined by the *remott2* suboperand of the T2TIMER keyword on the LINE statement.

N3GEN

Generated maximum number of I-frames to receive before sending an acknowledgement as defined by the *n3* suboperand of the T2TIMER keyword on the LINE statement.

CONGESTION (starting with NCP V7R6)

The station's role in congestion relief as defined by the third parameter of the TGCONF keyword on the PU definition statement:

- If the station can be used to relieve congestion, this field displays the station's threshold percentage.
- If the station can be used as a standby station but not to relieve congestion, this field displays NONE.
- If the station cannot be used as a standby station, this field displays N/A.

STATION (starting with NCP V7R6)

Whether the station can be used for hot standby (STANDBY) or cannot (NORMAL), as defined by the TGCONF keyword on the PU definition statement.

#PIUs/BLOCK (starting with NCP V6R2)

Generated maximum number of PIUs for each frame as defined by the *pius* suboperand of the BLOCK keyword on the PU statement.

MODE (starting with NCP V7R6)

Whether the station is in standby mode (STANDBY) or normal mode (NORMAL).

DYNWIND(NW,DW,DWC)

Values used by NCP to modify the IEEE 802.2 LLC working window parameter.

DYNWIND(NW) (starting with NCP V7R1)

Number of frames that must be received and acknowledged by the adjacent device before the sending NCP increases the IEEE 802.2 LLC working window value. When the sending NCP receives acknowledgements for *nw* consecutive I-frames, the working window value is increased until it reaches the value specified by MAXOUT for subarea connections, or the value specified in the VTAM switched major node for peripheral connections.

For a physical Token-Ring line, for NCP V7R1 through V7R4 the value in this field is defined by the *nw* suboperand of the DYNWIND keyword on the GROUP or LINE statement. For NCP V7R1 and V7R2, the value applies to all logical lines and stations associated with that physical line.

For a logical subarea Token-Ring station, for NCP V7R3 or later releases, the value in this field is defined by the *nw* suboperand of the DYNWIND keyword on the GROUP, LINE, or PU statement. For a peripheral station, for NCP V7R3 and later releases, the value is defined in the VTAM switched major node. Or if the value is not defined in VTAM, it is defined on the physical station's GROUP or LINE statement. Beginning with NCP V7R5, DYNWIND(*nw*) is also allowed on the PU statement for the physical station.

DYNWIND(DW) (starting with NCP V7R8; TIC1 and TIC2 resources only)

Value by which the sending NCP divides, or percentage by which the sending NCP reduces, the IEEE 802.2 LLC working window value when frame loss occurs. 1 is a special value which indicates that the working window value should be set to 1 when frame loss is detected.

The value in this field is defined by the *dw* suboperand of the DYNWIND keyword on the GROUP, LINE, or PU statement for a logical subarea Token-Ring station. For a peripheral station, the value is defined in the VTAM switched major node, or if not defined in VTAM, on the GROUP, LINE, or PU statement for the Token-Ring physical station.

DYNWIND(DWC) (starting with NCP V7R8; TIC1 and TIC2 resources only)

Value by which the sending NCP divides, or percentage by which the sending NCP reduces, the IEEE 802.2 LLC working window value when congestion is assumed. Congestion is assumed from the time an RNR frame is received until the time an RR frame is received. The working window is reduced only once for each period of congestion.

0 is a special value which indicates that the working window value will not be decreased during congestion. 1 is a special value which indicates that the working window value will be set to 1 during congestion.

The value in this field is defined by the *dwc* suboperand of the DYNWIND keyword on the GROUP, LINE, or PU statement for a logical subarea Token-Ring station. For a peripheral station, the value is defined in the VTAM switched major node, or if not defined in VTAM, on the GROUP, LINE, or PU statement for the physical Token-Ring station.

NCP TOKEN-RING TIC

Line Addr

Physical line address, TIC type (TIC1, TIC2, or TIC3), and Token-Ring speed (4 Mbps or 16 Mbps).

T/R Addr

MAC address of the TIC, as defined by the LOCADD keyword on the LINE statement.

SSAP (starting with NCP V7R5)

Source service access point, as defined by the SSAP keyword on the PU statement for Token-Ring logical subarea connections.

PHYPORT (starting with NCP V7R1)

Port address, as defined by the PORTADD keyword on the LINE statement.

status

TIC status: ACTIVE or INACTIVE.

DESTINATION STATION

Subarea Station or Boundary Station

Indicates whether this station is a subarea station or a boundary (peripheral) station.

IDBLK-IDNUM (peripheral stations)

Device type and identification number, as defined in the VTAM switched major node.

T/R Address

MAC address of the destination station. For logical subarea connections, the last 6 bytes specified for the ADDR keyword on the PU statement are the destination MAC address.

For logical peripheral connections, if the destination MAC address is not known, this field displays the message *Not Defined*.

UNIQUE (starting with NCP V7R6)

Whether the destination MAC address, as defined by the ADDR keyword on the PU statement for a Token-Ring logical subarea connection, is a unique locally administered address (YES) or a duplicate locally administered address (NO).

CPNAME

Control point name (type 2.1 PUs only).

TG

Transmission group number as defined by the TGN keyword on the PU statement.

SUBAREA

Address of the destination subarea.

LINE

Name of the NCP line going to the Token Ring.

DSAP

Destination service access point, part of the address field of LLC frames. For logical subarea connections, the first byte specified for the ADDR keyword on the PU statement is the DSAP.

status

Destination station PU status. The status can be any of the following:

INACTIVE	Reset
XID PEND	XID pending with data
XID NODT	XID pending without data
CONT PND	Contact pending
PENDING	Contact and discontact pending
ACTIVE	Active (normal data)
LOAD/DMP	Load/Dump/RPO active
SIM PEND	Set Initialization Mode pending
DISC PND	Discontact pending
LL2 ACT	Link-level 2 active
INOP PND	INOP pending
LL2 PND	Link-level 2 pending
INACT PD	Free-resource operation pending

NETID

For subarea stations, network identifier (NETID) of the adjacent NCP. For peripheral stations, NETID of the station at the other end of the link.

FRAME Statistics

Note: When defining frame size, be sure to consider the characteristics of the bridges and destination PU attached to the line.

MAXTSL/RCVBUFC

MAXTSL is the maximum outbound PIU size, as defined by the MAXTSL keyword on the LINE statement for the physical line. The maximum frame size is 36 bytes larger than this value. This value limits the maximum amount of TIC buffer space used to store outbound frames.

A type 2 or type 3 TIC can store two outbound frames at the same time. Most of the remaining storage is used for receiving frames. Because these TICs have 64K of storage, a much larger MAXTSL is normally recommended. For these TICs, this field is highlighted in reverse-video pink if MAXTSL is smaller than recommended. If this happens, you might want to increase MAXTSL to improve performance the next time you generate your NCP.

RCVBUFC, which is displayed for a type 1 or type 2 TIC, is the maximum inbound frame size, as defined by the RCVBUFC keyword on the LINE statement for the physical line.

The TIC might need to store more than one frame at a time. It is recommended that the RCVBUFC value be at least twice the size of the largest frames the TIC will receive. For a type 2 TIC, this field is highlighted in reverse-video green if RCVBUFC is smaller than recommended. If this happens, you may want to increase RCVBUFC to improve performance the next time you generate your NCP.

Frames Count (type 1 or type 2 TIC)

Traffic rate for frames sent and received by this NCP, calculated by the number of frames sent or received since the panel was entered or since the last time F12=REFRESH was pressed. The same value is displayed on both sides.

If the traffic rate is greater than one frame per second, NTuneMON displays the rate in frames per second (n/S). If the rate is less than one frame per second, NTuneMON displays the actual number of frames sent and received.

This traffic rate is displayed in reverse-video yellow if any traffic is detected. Hexadecimal send/receive sequence numbers are displayed in turquoise if no traffic is detected.

The traffic rate may be inaccurate the first time you press F12=REFRESH after a long delay.

WW/Outs. Frame ct

WW (working window), which is displayed for a type 1 or type 2 TIC, is the current maximum number of frames NCP can send to the destination station before requiring an acknowledgement. The generated value is defined by the MAXOUT keyword on the PU statement for the logical line. The current value may be less than the defined value because NCP reduces the current value if congestion is detected.

OUTs. Frame ct (outstanding frames count) is the number of frames currently waiting for acknowledgement. When this number reaches WW, no frames can be transmitted until an acknowledgement is received.

N3/I-frame Rcv ct

N3 is the current value for the maximum number of I-frames to receive before sending an acknowledgement. For subarea stations, N3 is initialized from N3GEN.

I-frame Rcv ct (I-frame received counter) is the current number of I-frames received without sending an acknowledgement. This value is initialized to the value for N3 and decremented by one each time an I-frame is received.

CUR GEN

This section displays current and generated values for parameters. CUR is the current working value and is either set or limited by GEN. GEN is either the value from the NCP generation or the value resulting from subsequent NCP processing that overwrote the value from the NCP generation.

MAXDATA CUR (starting with NCP V6R2)

Current maximum inbound data² size for the destination station. This field is a working value that is either set or limited by the MAXDATA GEN field.

For a type 2 TIC, this field is highlighted in reverse-video pink when the value is smaller than is normally recommended. If this happens, you may want to increase the MAXTSL value for the destination station, to improve performance, the next time you generate your NCP.

MAXDATA GEN (starting with NCP V6R2)

Generated maximum inbound data² size for the destination station. GEN is either the value from the NCP generation (MAXDATA keyword on the PU statement) or the value resulting from subsequent NCP processing that overwrote the generated value.

MAXOUT CUR

Current maximum number of frames NCP can send to the destination station before requiring an acknowledgement. This field is a working value that is either set or limited by the MAXOUT GEN field.

MAXOUT GEN

Generated maximum number of frames that NCP can send to the destination station before requiring an acknowledgement. GEN is either the value from the NCP generation (MAXOUT keyword on the PU statement) or the value resulting from subsequent NCP processing that overwrote the generated value.

BLOCK CUR (starting with NCP V6R2)

Current maximum frame size. This is a working value that is either set or limited by the BLOCK GEN field for this station and the adjacent link station.

BLOCK GEN (starting with NCP V6R2)

Generated maximum frame size. GEN is either the value from the NCP generation (*bytes* suboperand of the BLOCK keyword on the PU statement) or the value resulting from subsequent NCP processing that overwrote the generated value.

PIUCHECK CUR (starting with NCP V7R7; subarea stations only)

Current YES or NO value indicating whether a checksum validation is performed on PIUs sent from and received by this station. This field is a working

² The data size does not include any header information.

value that is either set or limited by the PIUCHECK GEN field for this station and the adjacent link station.

PIUCHECK GEN (starting with NCP V7R7; subarea stations only)

Generated YES or NO value indicating whether a checksum validation is performed on PIUs sent from and received by this station. Unless tuned, this field is the value from the NCP generation (PIUCHECK keyword on the PU statement).

PF Keys

F1=HELP

Displays online help for this panel.

F2=DISG STATION PU

Displays a graphic representation of the station (DISG CLIST). This display is useful for viewing the VTAM switched major node for peripheral stations. For this display, NTuneMON must be running on the VTAM host that owns the line.

F3=RETURN

Returns to the previous NTuneMON panel.

F4=Force Reroute (starting with NCP V7R7)

Available when:

- The operator has tuning authority.
- NTuneNCP is included.
- The NTRI logical subarea connection is a bridged connection.
- The link station is active.
- The link is open.
- Nondisruptive route switching (NDRS) has not already been initiated for this subarea connection.

Requests that NCP initiate NDRS to locate another possible bridged route for the associated NTRI subarea connection. NCP will notify you of its progress, and if the rerouting is successful, you will be able to refresh the panel and see the new route. See messages ATUM711 and ATUM712 on page 9-11 for more information.

F5=MODIFY

Available when the operator has tuning authority and NTuneNCP is included. For more information, refer to Chapter 5, Using the NTuneNCP Tuning Feature.

Updates the NCP tuning parameter with the modified value. If the modification is not valid, the field turns reverse-video pink, and you are prompted to correct the value and resubmit it.

F6=ROLL

Returns to the NetView command line without exiting NTuneMON. To return to NTuneMON from the NetView program, press F6=ROLL or enter **ATUNEMON** on the NetView command line.

F10=HEX

Displays the ATUDP Hexadecimal Storage Display panel, as shown on page 4-68, to show the logical link control block (LLB) for a type 1 or type 2 TIC, or the Token-Ring logical station block extension (TSB) for a type 3 TIC.

ENTER=TG DETAILS(SUBAREA ONLY)

Displays the ATUML Multi-Link Transmission Group panel, as shown on page 4-184, for more information about the transmission group and the origin and destination NCPs.

F12=REFRESH

Refreshes the information on this panel.

PA1=EXIT

Exits NTuneMON.

PA2=LOG

Saves the information on this panel to the NetView log.

ATUTP1 Token-Ring TIC Details Page 1 Panel

Basic fast-path commands: None

Tuning fields: T/R LOCADD, TITIMER, DYNWIND(nw), DYNWIND(dw), DYNWIND(dwc), Conn Bal Fact

```

ATUTP1 A27GENC Token-Ring TIC Details Page 1 NTuneMON V2R6 13:42
OWNERPL Function Active = NO Elapsed Time = 0
Default View= MAC Dual= Status= ACTIVE TIC= 1092 Find=

  NCP ADAPTER ATTACHMENT                                LAST BEACONING INFORMATION
  Line Address= 1092 TIC2 16M                            NO BEACONING |--X--| N/A
  T/R LOCADD = 400000000001                               |-----|-----|
  Port Address= 1 ECL= BNN                                Time: N/A      Date: N/A
  Active Lines= 0
  Reserved Lines= 250 0% Active
  SNA PASSLIM = N/A
  IP PASSLIM = N/A

  Token-Ring Adapter Status
  INACTIVE

  FRAME INFORMATION                                     TITIMER = 60.0
  MAXTSL Maximum Transmit PIU Size = 16732             DYNWIND(nw) = 4
  RCVBUFC Maximum Receive Frame Size = 1440           DYNWIND(dw) = 2
  DATABLK Data Block Size = 2048                     DYNWIND(dwc) = 1
  MAXFRAME Maximum Frame Size = N/A                  Conn Bal Fact = 2
  Receive Congestion Counter = 0                      Log BNN Conn = 0

=>
F1=HELP F2=SUBAREA F3=RETURN F4=BNN IDBLK-IDNUM F5=MODIFY F6=ROLL
F7=MAC ADDR F8=SNA STATIONS (ALL TICs) F9=ALT-PAGE F10=HEX F11=ALT-PFKs
ENTER=SNA STATIONS F12=REFRESH/TRAFFIC RATES PA1=EXIT PA2=LOG
    
```

Figure 4-91. ATUTP1 Token-Ring TIC Details Page 1 Panel

Description

The ATUTP1 Token-Ring TIC Details Page 1 panel, which is available for NCP V5R4 or later releases, displays detailed information for a specific type 1, type 2, or type 3 TIC. A 3746 Model 900 is a type 3 TIC.

To display this panel:

- On the ATUSC4 3746 Model 900 Adapters panel, as shown on page 4-237, place the cursor under the line address for a TRP or CBTRP adapter and press Enter.
- On the ATUTC Token-Ring Adapter List panel, as shown on page 4-278, place the cursor under a TIC address and press Enter.
- From the ATUTP2 Token-Ring TIC Details Page 2 panel, as shown on page 4-319, press F9.

See the descriptions of the panels for more information.

Fields

NCP name (second field on panel)

Name of the NCP that is currently displayed.

OWNERPL Function Active

Whether the OWNERPL function is active:

YES The Token-Ring unassigned logical resources (PHYSRSC=NONE or PHYPORT=NONE) are being allocated to this physical line based on common SSCP ownership of the physical and logical resources. (This line's resource type, NTRI or ODLCTR, was specified on the OWNERPL keyword on the BUILD statement.)

NO The OWNERPL function is not active. (The OWNERPL keyword was not coded on the BUILD statement; or this line's resource type, NTRI or ODLCTR, was not specified on the OWNERPL keyword.)

Elapsed Time

Amount of time that has passed from panel entry until the panel is refreshed or the amount of time that has passed since the statistics were last refreshed.

Default View

Value in the VIEW DEFAULT field On the ATUTC Token-Ring Adapter List panel, as shown on page 4-278, or the DEFAULT VIEW field on the ATUTA Token-Ring SNA Station List panel, as shown on page 4-273.

Dual

Value in the (DUAL) field on the ATUTC Token-Ring Adapter List panel, as shown on page 4-278, or the DUAL field on the ATUTA Token-Ring SNA Station List panel, as shown on page 4-273.

Status

Value in the STATUS DEFAULT field on the ATUTC Token-Ring Adapter List panel, as shown on page 4-278, or the STATUS field on the ATUTA Token-Ring SNA Station List panel, as shown on page 4-273.

TIC

Address of the physical line attached to the TIC.

Find

Value in the FOR DIRECT FIND ENTER ONE section on the ATUTC Token-Ring Adapter List panel as shown on page 4-278.

NCP ADAPTER ATTACHMENT

Line Address

Physical line address, TIC type (TIC1, TIC2, or TIC3) and Token-Ring speed (4 Mbps or 16 Mbps).

T/R LOCADD

MAC address of the TIC, as defined by the LOCADD keyword on the LINE statement.

Port Address

Port address, as defined by the PORTADD keyword on the LINE statement.

ECL

Types of stations that can use this line (peripheral (BNN), subarea (SUB), or both (ANY)), as defined by the ECLTYPE keyword on the GROUP statement.

Active Lines

Number of active logical lines going through the TIC.

Notes:

1. For type 1 and type 2 TICs, logical subarea lines are always included in the active count, whether they are active or not.
2. The active count can be greater than the reserved count because any active unreserved logical lines through this TIC are included in this TIC's active count but are not included in this TIC's reserved count.

Reserved Lines

Number of logical lines associated with this TIC, and the percentage of these lines currently active. If this value exceeds the threshold defined on the ATUTC Token-Ring Adapter List panel, as shown on page 4-278, NTuneMON highlights the field in reverse-video red and issues a generic alert (if specified).

Note: PHYPORT can be coded for NTRI peripheral logical GROUPs and, starting with NCP V7R8, for 3746 Model 900 Token-Ring peripheral logical GROUPs. Any **inactive** Token-Ring logical lines with PHYPORT=*number* coded will be counted in the Reserved Lines count for the first physical whose PORTADD is *number* if more than one physical has a PORTADD equal to *number*. Once the inactive PHYPORT=*number* logical is active, it will be counted in the Reserved Lines count for the physical over which it is active.

Station state (to right of Reserved Lines)

One of the following is displayed to indicate the status of the physical link station:

INACTIVE	Reset
XID PEND	XID pending with data
XID NODT	XID pending without data
CONT PND	Contact pending
PENDING	Contact and discontact pending
ACTIVE	Active (normal data)
LOAD/DMP	Load/Dump/RPO active
SIM PEND	Set Initialization Mode pending
DISC PND	Discontact pending
LL2 ACT	Link-level 2 active
INOP PND	INOP pending
LL2 PND	Link-level 2 pending
INACT PD	Free-resource operation pending

SNA PASSLIM (NCP V7R1 or V7R2)

Maximum number of consecutive Token-Ring SNA frames NCP is to transmit before checking for Token-Ring internet frames to be transmitted. This can help you control the mixture of internet and SNA traffic over this Token-Ring attachment. Defined by the PASSLIM keyword of the PU statement.

IP PASSLIM (NCP V7R1 or V7R2)

Maximum number of consecutive Token-Ring internet frames NCP is to transmit before checking for Token-Ring SNA frames to be transmitted. This can help you control the mixture of internet and SNA traffic over this Token-Ring attachment. Defined by the PASSLIM keyword of the PU statement.

LAST BEACONING INFORMATION

For a type 1 or type 2 TIC, this section displays the last beaconing MAC address and its nearest active upstream neighbor, if reported. For a type 3 TIC, only BEACONING is displayed when the TIC is beaconing.

Time (starting with NCP V7R7; not applicable to 3746 Model 900)

The time stamp for the last beaconing information, displayed as relative NCP time in *hh:mm* format.

Date (starting with NCP V7R7; not applicable to 3746 Model 900)

The date stamp for the last beaconing information, displayed as a relative NCP date in *mm/dd/yyyy* format.

Token-Ring Adapter Status

This section displays the status of the TIC, which will be one of the following:

PEND ACTLINK	An activate link command (ACTLINK) is in progress.
ACTIVE	An ACTLINK has been processed, and the line is active.
PEND DACTLNK	A deactivate link command (DACTLINK) is in progress.
INACTIVE	A DACTLINK has been processed, and the line is inactive.
FORCE DEACT	The line has been forced into deactivation. (A force deactivate command was issued from VTAM.)
PEND ANS	Line quiescence is pending due to automatic network shutdown (ANS).

For a type 1 or type 2 TIC, if the TIC is inactive and an error has occurred, one of the following messages is displayed in reverse-video red. (Refer to *Token-Ring Network Problem Determination Guide* for more information on these errors.)

SIGNAL LOSS	A loss of the received signal was detected.
HARD ERROR	The beaconing timeout was exceeded.
SOFT ERROR	This TIC has transmitted a soft error report MAC frame.
XMIT BEACON	This adapter is transmitting beacon frames.
LOBE WIRE	An open or short circuit was detected in the lobe data path, and the TIC was closed.
AUTO REMOVAL	A TIC hardware error was detected, and the TIC was closed.
REMOVED	This TIC received a remove MAC frame and was closed. This can be caused by a LAN managing program, such as the IBM LAN Network Manager, issuing a remove adapter command.
RING RECOVERY	The Token-Ring is beaconing and attempting to recover.

FRAME INFORMATION**MAXTSL**

Maximum outbound PIU size, as defined by the MAXTSL keyword on the LINE statement for the physical line. The maximum frame size is 36 bytes larger than this value. This value limits the maximum amount of TIC buffer space used to store outbound frames.

A type 2 or type 3 TIC can store two outbound frames at the same time. Most of the remaining storage is used for receiving frames. Because these TICs have 64K of storage, a much larger MAXTSL is normally recommended. For these TICs, this field is highlighted in reverse-video pink if MAXTSL is smaller than is normally recommended. If this happens, you may want to increase MAXTSL to improve performance the next time you generate your NCP.

Note: When defining frame size, be sure to consider the characteristics of the bridges and destination PU attached to the line.

RCVBUFC (type 1 or type 2 TIC)

Maximum inbound frame size, as defined by the RCVBUFC keyword on the LINE statement for the physical line.

The TIC may need to store more than one frame at a time. It is recommended that the RCVBUFC value be at least twice the size of the largest frames the TIC will receive. For a type 2 TIC, this field is highlighted in reverse-video green if RCVBUFC is smaller than is normally recommended. If this happens, you may want to increase RCVBUFC to improve performance the next time you generate your NCP.

DATABLK (starting with NCP V7R3; type 1 or type 2 TIC)

Minimum guaranteed transmission bandwidth (in bytes) that can be allocated to a protocol. Defined by the DATABLK keyword on the LINE statement. The DATABLK keyword is used with the *priority* suboperand of the COMRATE keyword on the PU statement to determine a relative priority among all supported protocols. The value of *priority* is multiplied by the value of DATABLK to determine the guaranteed minimum number of bytes afforded a protocol for the transmission of associated traffic before a different protocol is given a transmission opportunity.

MAXFRAME (starting with NCP V7R3; frame relay over Token Ring; type 1 or type 2 TIC)

Maximum size (in bytes) of frames that can be transmitted and received over the physical line for a frame-relay interface. Defined by the MAXFRAME keyword of the physical LINE statement.

Receive Congestion Counter (type 1 or type 2 TIC)

Number of frames NCP failed to receive due to congestion in the TIC. This field is only updated when the following occurs:

- The TIC is being disabled either by an INACT or INOP command
- When a ring status change is received from the TIC with the counter overflow bit on.

TITIMER (starting with NCP V7R1)

Inactivity Timer (TI) interval, in seconds, that NCP is to wait for a transmitted frame from an adjacent station before sending a poll command. Defined by the TITIMER keyword on the LINE statement for the physical Token-Ring line. The TI value that is specified on the physical line will be used by the logical lines associated with that physical line.

DYNWIND(nw) (starting with NCP V7R1)

Number of frames that must be received and acknowledged by the adjacent device before the sending NCP increases the IEEE 802.2 LLC working window value. When the sending NCP receives acknowledgements for *nw* consecutive I-frames, the working window value is increased until it reaches

the value specified by MAXOUT for subarea connections, or the value specified in the VTAM switched major node for peripheral connections.

For a physical Token-Ring line, for NCP V7R1 through V7R4, the value in this field is defined by the *nw* suboperand of the DYNWIND keyword on the GROUP or LINE statement. For NCP V7R1 and V7R2, the value applies to all logical lines and stations associated with that physical line.

For a logical subarea Token-Ring station, for NCP V7R3 or later releases, the value in this field is defined by the *nw* suboperand of the DYNWIND keyword on the GROUP, LINE, or PU statement. For a peripheral station, for NCP V7R3 and later releases, the value is defined in the VTAM switched major node. Or if the value is not defined in VTAM, it is defined on the physical station's GROUP or LINE statement. Beginning with NCP V7R5, DYNWIND(*nw*) is also allowed on the PU statement for the physical station.

DYNWIND(dw) (starting with NCP V7R8; TIC1 and TIC2 resources only)

Value by which the sending NCP divides, or percentage by which the sending NCP reduces, the IEEE 802.2 LLC working window value when frame loss occurs. 1 is a special value which indicates that the working window value will be set to 1 when frame loss is detected.

The value in this field is defined by the *dw* suboperand of the DYNWIND keyword on the GROUP, LINE, or PU statement for a logical subarea Token-Ring station. For a peripheral station, the value is defined in the VTAM switched major node, or if not defined in VTAM, on the GROUP, LINE, or PU statement for the Token-Ring physical station.

DYNWIND(dwc) (starting with NCP V7R8; TIC1 and TIC2 resources only)

Value by which the sending NCP divides, or percentage by which the sending NCP reduces, the IEEE 802.2 LLC working window value when congestion is assumed. Congestion is assumed from the time an RNR frame is received until the time an RR frame is received. The working window is reduced only once for each period of congestion.

0 is a special value which indicates that NCP will not reduce the working window during congestion. 1 is a special value which indicates that the working window value will be set to 1 during congestion.

The value in this field is defined by the *dwc* suboperand of the DYNWIND keyword on the GROUP, LINE, or PU statement for a logical subarea Token-Ring station. For a peripheral station, the value is defined in the VTAM switched major node, or if not defined in VTAM, on the GROUP, LINE, or PU statement for the physical Token-Ring station.

Conn Bal Fact (starting with NCP V7R6)

The TIC's connection balancing factor, as specified in the BALANCE keyword on the GROUP or LINE definition statement.

Log BNN Conn

The number of established, associated logical peripheral connections. If a TIC3 is being shared between NCP and the NNP, the count reflects only those connections activated through NCP.

PF Keys

PF Key Selection Number 1

This is the default set of PF keys for this panel.

F1=HELP

Displays online help for this panel.

F2=SUBAREA

Displays the ATUTA Token-Ring SNA Station List panel, as shown on page 4-273, to show all subareas with connections through this TIC.

F3=RETURN

Returns to the previous NTuneMON panel.

F4=BNN IDBLK-IDNUM

Displays the ATUTA Token-Ring SNA Station List panel, as shown on page 4-273, to show the IDBLK-IDNUM for all SNA logical stations going through this TIC.

F5=MODIFY

Available when the operator has tuning authority and NTuneNCP is included. For more information, refer to Chapter 5, Using the NTuneNCP Tuning Feature.

Updates the NCP tuning parameter with the modified value. If the modification is not valid, the field turns reverse-video pink, and you are prompted to correct the value and resubmit it.

F6=ROLL

Returns to the NetView command line without exiting NTuneMON. To return to NTuneMON from the NetView program, press F6=ROLL or enter **ATUNEMON** on the NetView command line.

F7=MAC ADDR

Displays the ATUTA Token-Ring SNA Station List panel, as shown on page 4-273, to show MAC addresses for all SNA logical stations associated with this TIC. This resets your default and dual view from the ATUTC Token-Ring Adapter List panel, as shown on page 4-278.

F8=SNA STATIONS (ALL TICs)

Displays the ATUTA Token-Ring SNA Station List panel, as shown on page 4-273, to show information on the SNA logical stations associated with this TIC. The stations displayed are determined by the value in the STATUS DEFAULT field on the ATUTC Token-Ring Adapter List panel, as shown on page 4-278. The information displayed for each station is determined by the values in the VIEW DEFAULT and (DUAL) fields on the ATUTC Token-Ring Adapter List panel.

F9=ALT-PAGE (starting with NCP V7R3)

Scrolls forward to the ATUTP2 Token-Ring TIC Details Page 2 panel, as shown on page 4-319, to show more detailed information on this TIC.

F10=HEX

Displays the ATUDP Hexadecimal Storage Display panel, as shown on page 4-68, to show the physical link control block (PLB) for a type 1 or type 2 TIC, or the Token-Ring line block extension (TLB) for a type 3 TIC.

F11=ALT-PFKs

Resets some of the PF keys on this panel to do different functions. These alternate PF keys are shown in Figure 4-92 on page 4-317.

ENTER=SNA STATIONS

Displays the ATUTA Token-Ring SNA Station List panel, as shown on page 4-273, to show information on the SNA logical stations associated with this TIC. The stations displayed are determined by the value in the STATUS DEFAULT field on the ATUTC Token-Ring Adapter List panel, as shown on page 4-278. The information displayed for each station is determined by the values in the VIEW DEFAULT and (DUAL) fields on the ATUTC Token-Ring Adapter List panel.

F12=REFRESH/TRAFFIC RATES

Refreshes the information on this panel.

Note: Traffic rates are refreshed when this key is pressed from the ATUTP2 Token-Ring TIC Details Page 2 panel, as shown on page 4-319.

PA1=EXIT

Exits NTuneMON.

PA2=LOG

Saves the information on this panel to the NetView log.

PF Key Selection Number 2

Figure 4-92 shows the second set of PF keys for the ATUTP1 panel. These alternate functions are enabled when you press F11=ALT-PFKs in the first PF key selection.

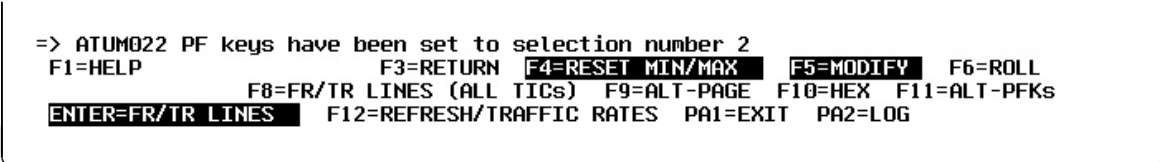

Figure 4-92. PF Key Selection Number 2 for the ATUTP1 Token-Ring TIC Details Page 1 Panel

F1=HELP

Displays online help for this panel.

F2=TR IP STATS (starting with NCP V7R1; IP over Token Ring)

Displays the ATUTI Token-Ring IP Statistics panel, as shown on page 4-298, to show Token-Ring IP statistics.

F3=RETURN

Returns to the previous NTuneMON panel.

F4=RESET MIN/MAX (starting with NCP V7R3; type 1 or type 2 TIC)

Available when the operator has tuning authority and NTuneNCP is included. For more information, refer to Chapter 5, Using the NTuneNCP Tuning Feature.

Valid only from the ATUTP2 Token-Ring TIC Details Page 2 panel.

F5=MODIFY

Available when the operator has tuning authority and NTuneNCP is included. For more information, refer to Chapter 5, Using the NTuneNCP Tuning Feature.

Updates the NCP tuning parameter with the modified value. If the modification is not valid, the field turns reverse-video pink, and you are prompted to correct the value and resubmit it.

F6=ROLL

Returns to the NetView command line without exiting NTuneMON. To return to NTuneMON from the NetView program, press F6=ROLL or enter **ATUNEMON** on the NetView command line.

F7=IP DETAILS (starting with NCP V7R1; IP over Token Ring)

Displays the ATUID IP Interface Information Detail panel, as shown on page 4-164, to show detailed information about an IP interface that is connected to this physical Token Ring.

F8=FR/TR LINES (ALL TICs) (starting with NCP V7R3; frame relay over Token Ring; type 1 and type 2 TICs)

Displays the ATUTF NTRI Frame Handler Logical Lines panel, as shown on page 4-291, to show information on the NTRI frame handler logical lines associated with all type 1 and type 2 TICs.

F9=ALT-PAGE (starting with NCP V7R3)

Scrolls forward to the ATUTP2 Token-Ring TIC Details Page 2 panel, as shown on page 4-319, to show more detailed information on this TIC.

F10=HEX

Displays the ATUDP Hexadecimal Storage Display panel, as shown on page 4-68, to show the physical link control block (PLB) for a type 1 or type 2 TIC, or the Token-Ring line block extension (TLB) for a type 3 TIC.

F11=ALT-PFKs

Resets the PF keys on this panel to perform their original functions as described under "PF Keys" on page 4-316.

ENTER=FR/TR LINES (starting with NCP V7R3; frame relay over Token Ring)

Displays the ATUTF NTRI Frame Handler Logical Lines panel, as shown on page 4-291, to show information on the NTRI frame handler logical lines associated with this TIC.

F12=REFRESH/TRAFFIC RATES

Refreshes the information on this panel.

Note: Traffic rates are refreshed when this key is pressed from the ATUTP2 Token-Ring TIC Details Page 2 panel, as shown on page 4-319.

PA1=EXIT

Exits NTuneMON.

PA2=LOG

Saves the information on this panel to the NetView log.

ATUTP2 Token-Ring TIC Details Page 2 Panel

Basic fast-path commands: None

Tuning fields: COMRATE

```

ATUTP2  A04NT06  Token-Ring TIC Details Page 2  NTuneMON V2R1  11:21
                                           Elapsed Time = 0
Default View= SUB  Dual= MAC  Status= ACTIVE  TIC= 1088 Find=

      FRAME INFORMATION
MAXTSL = 16732  RCVBUFC = 32000  DATABLK = 2048  MAXFRAME = 8000

      COMRATE  Max Size  Min Size  Number of  Estimated
              Frame Sent  Frame Sent  Frames Sent  Bytes Sent
-----
TIC          N/A          -          -          -          -
FR           1            -          -          -          -
SNA          1            -          -          -          -

=> ATUM017 Press F12 to see Traffic or Polling rates
F1=HELP  F2=SUBAREA  F3=RETURN  F4=BNN IDBLK-IDNUM  F5=MODIFY  F6=ROLL
F7=MAC ADDR  F8=SNA STATIONS (ALL TICs)  F9=ALT-PAGE  F10=HEX  F11=ALT-PFKs
ENTER=SNA STATIONS  F12=REFRESH/TRAFFIC RATES  PA1=EXIT  PA2=LOG
  
```

Figure 4-93. ATUTP2 Token-Ring TIC Details Page 2 Panel

Description

The ATUTP2 Token-Ring TIC Details Page 2 panel, which is available for NCP V7R3 or later releases, displays detailed information for a specific type 1 or type 2 TIC.

To display this panel: On the ATUTP1 Token-Ring TIC Details Page 1 panel, as shown on page 4-310, press F9.

Fields

NCP name (second field on panel)

Name of the NCP that is currently displayed.

Elapsed Time

The amount of time that has passed from panel entry until the panel is refreshed or the amount of time that has passed since the statistics were last refreshed.

Default View

Value in the VIEW DEFAULT field on the ATUTC Token-Ring Adapter List panel, as shown on page 4-278, or the DEFAULT VIEW field on the ATUTA Token-Ring SNA Station List panel, as shown on page 4-273.

Dual

Value in the (DUAL) field on the ATUTC Token-Ring Adapter List panel, as shown on page 4-278, or the DUAL field on the ATUTA Token-Ring SNA Station List panel, as shown on page 4-273.

Status

Value in the STATUS DEFAULT field on the ATUTC Token-Ring Adapter List panel, as shown on page 4-278, or the STATUS field on the ATUTA Token-Ring SNA Station List panel, as shown on page 4-273.

TIC

Address of the physical line attached to the TIC.

Find

Value in the FOR DIRECT FIND ENTER ONE section on the ATUTC Token-Ring Adapter List panel as shown on page 4-278.

FRAME INFORMATION

This section of the panel displays frame information for this type 1 or type 2 TIC and its associated protocols as represented by Token-Ring physical stations (SNA, IP, or frame relay).

MAXTSL

Maximum outbound PIU size, as defined by the MAXTSL keyword on the LINE statement for the physical line. The maximum frame size is 36 bytes larger than this value. This value limits the maximum amount of TIC buffer space used to store outbound frames.

A type 2 can store two outbound frames at the same time. Most of the remaining storage is used for receiving frames. Because these TICs have 64K of storage, a much larger MAXTSL is normally recommended. For these TICs, this field is highlighted in reverse-video pink if MAXTSL is smaller than is normally recommended. If this happens, you may want to increase MAXTSL to improve performance the next time you generate your NCP.

Note: When defining frame size, be sure to consider the characteristics of the bridges and destination PU attached to the line.

RCVBUFC

Maximum inbound frame size, as defined by the RCVBUFC keyword on the LINE statement for the physical line.

The TIC may need to store more than one frame at a time. It is recommended that the RCVBUFC value be at least twice the size of the largest frames the TIC will receive. For a type 2 TIC, this field is highlighted in reverse-video green if RCVBUFC is smaller than is normally recommended. If this happens, you may want to increase RCVBUFC to improve performance the next time you generate your NCP.

DATABLK

Minimum guaranteed transmission bandwidth (in bytes) that can be allocated to a protocol. Defined by the DATABLK keyword on the LINE statement. The DATABLK keyword is used with the *priority* suboperand of the COMRATE keyword on the PU statement to determine a relative priority among all supported protocols. The value of *priority* is multiplied by the value of DATABLK to determine the guaranteed minimum number of bytes afforded a protocol for the transmission of associated traffic before a different protocol is given a transmission opportunity.

MAXFRAME (frame relay over Token Ring)

Maximum size (in bytes) for frames that can be transmitted or received over the physical line for a frame-relay interface. Defined by the MAXFRAME keyword of the physical LINE statement.

TIC, SNA, IP, FR

Frame information is displayed for the TIC and for each protocol as represented by a Token-Ring physical station (SNA, IP, or frame relay).

COMRATE (not applicable for the TIC)

Relative transmit priority for a protocol as represented by a Token-Ring physical station (SNA, IP, or frame relay). Defined by the *priority* suboperand of the COMRATE keyword on the PU statement. *Priority* is multiplied by the value of the DATBLK keyword on the LINE statement to determine the guaranteed minimum number of bytes that the protocol can transmit before a different protocol must be given a transmission opportunity.

Max Size Frame Sent

Maximum size frame (in bytes) sent by this TIC or protocol (SNA, IP, or frame relay) since the last time this field was reset by NTuneMON. When you reset this field by selecting the TIC or a protocol with your cursor and pressing F4, NTuneMON automatically refreshes the panel and displays the new traffic rate if it is available. Otherwise, NTuneMON displays a dash (–) until the new traffic rate is available and you press F12 or reenter the panel to display the new rate.

Note: Set the NTUNECOL keyword on the BUILD definition statement to YES to allow this data to be collected and displayed.

Min Size Frame Sent

Minimum size frame (in bytes) sent by this TIC or protocol (SNA, IP, or frame relay) since the last time this field was reset by NTuneMON. When you reset this field by selecting the TIC or a protocol with your cursor and pressing F4, NTuneMON automatically refreshes the panel and displays the new traffic rate if it is available. Otherwise, NTuneMON displays a dash (–) until the new traffic rate is available and you press F12 or reenter the panel to display the new rate.

Note: Set the NTUNECOL keyword on the BUILD definition statement to YES to allow this data to be collected and displayed.

Number of Frames Sent

Number of frames sent by this TIC or protocol (SNA, IP, or frame relay). When this panel is entered, it displays the number of frames. When F12 is pressed, the panel displays frames per second (*n/Sec*).

Notes:

1. The number of frames for the TIC might not equal the sum of the frames for all of the specified protocols.
2. Set the NTUNECOL keyword on the BUILD definition statement to YES to allow this data to be collected and displayed.

Estimated Bytes Sent

Estimated bytes per second (*n/SEC*) sent by this TIC or protocol (SNA, IP, or frame relay). The number of bytes is estimated by taking the average of the maximum size frame sent and the minimum size frame sent. To get a more current estimate, press F4 to reset the Max Size Frame Sent and Min Size Frame Sent fields. NTuneMON resets the fields and automatically refreshes the panel. If new traffic rates are available, they are displayed. Otherwise, a dash (–) is displayed until new traffic rates are available and you press F12 to refresh the traffic rates.

Note: Set the NTUNECOL keyword on the BUILD definition statement to YES to allow this data to be collected and displayed.

PF Keys

PF Key Selection Number 1

This is the default set of PF keys for this panel.

F1=HELP

Displays online help for this panel.

F2=SUBAREA

Displays the ATUTA Token-Ring SNA Station List panel, as shown on page 4-273, to show all subareas with connections through this TIC.

F3=RETURN

Returns to the previous NTuneMON panel.

F4=BNN IDBLK-IDNUM

Displays the ATUTA Token-Ring SNA Station List panel, as shown on page 4-273, to show the IDBLK-IDNUM for all SNA logical stations going through this TIC.

F5=MODIFY

Available when the operator has tuning authority and NTuneNCP is included. For more information, refer to Chapter 5, Using the NTuneNCP Tuning Feature.

Updates the NCP tuning parameter with the modified value. If the modification is not valid, the field turns reverse-video pink, and you are prompted to correct the value and resubmit it.

F6=ROLL

Returns to the NetView command line without exiting NTuneMON. To return to NTuneMON from the NetView program, press F6=ROLL or enter **ATUNEMON** on the NetView command line.

F7=MAC ADDR

Displays the ATUTA Token-Ring SNA Station List panel, as shown on page 4-273, to show MAC addresses for all SNA logical stations associated with this TIC. This resets your default and dual view from the ATUTC Token-Ring Adapter List panel, as shown on page 4-278.

F8=SNA STATIONS (ALL TICs)

Displays the ATUTA Token-Ring SNA Station List panel, as shown on page 4-273, to show information on the SNA logical stations associated with this TIC. The stations displayed are determined by the value in the STATUS DEFAULT field on the ATUTC Token-Ring Adapter List panel, as shown on page 4-278. The information displayed for each station is determined by the values in the VIEW DEFAULT and (DUAL) fields on the ATUTC Token-Ring Adapter List panel.

F9=ALT-PAGE

Scrolls back to the ATUTP1 Token-Ring TIC Details Page 1 panel as shown on page 4-310, to show more detailed information on this TIC.

F10=HEX

Displays the ATUDP Hexadecimal Storage Display panel, as shown on page 4-68, to show the physical link control block (PLB) for a type 1 or type 2 TIC, or the Token-Ring line block extension (TLB) for a type 3 TIC.

F11=ALT-PFKs

Resets some of the PF keys on this panel to do different functions. These alternate PF keys are shown in Figure 4-94.

ENTER=SNA STATIONS

Displays the ATUTA Token-Ring SNA Station List panel, as shown on page 4-273, to show information on the SNA logical stations associated with this TIC. The stations displayed are determined by the value in the STATUS DEFAULT field on the ATUTC Token-Ring Adapter List panel, as shown on page 4-278. The information displayed for each station is determined by the values in the VIEW DEFAULT and (DUAL) fields on the ATUTC Token-Ring Adapter List panel.

F12=REFRESH/TRAFFIC RATES

Refreshes the information on this panel and displays traffic rates.

PA1=EXIT

Exits NTuneMON.

PA2=LOG

Saves the information on this panel to the NetView log.

PF Key Selection Number 2

Figure 4-94 shows the second set of PF keys for the ATUTP2 panel. These alternate functions are enabled when you press F11=ALT-PFKs in the first PF key selection.

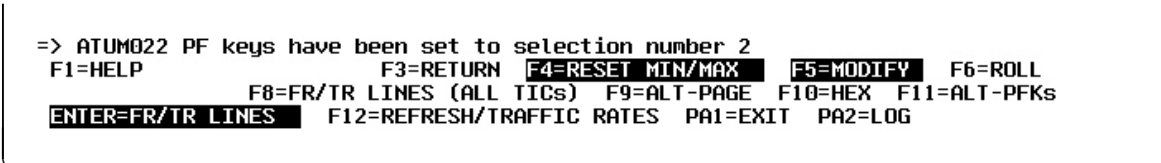

Figure 4-94. PF Key Selection Number 2 for the ATUTP2 Token-Ring TIC Details Page 2 Panel

F1=HELP

Displays online help for this panel.

F2=TR IP STATS (IP over Token Ring)

Displays the ATUTI Token-Ring IP Statistics panel, as shown on page 4-298, to show Token-Ring IP statistics.

F3=RETURN

Returns to the previous NTuneMON panel.

F4=RESET MIN/MAX

Available when the operator has tuning authority and NTuneNCP is included. For more information, refer to Chapter 5, Using the NTuneNCP Tuning Feature.

Resets the values of the Max Size Frame Sent and Min Size Frame Sent fields. After resetting the fields, NTuneMON automatically refreshes the panel. If new traffic rates are available, they are displayed. Otherwise, NTuneMON displays a dash (–) until new traffic rates are available and you press F12 or reenter the panel to display the new rates. To reset these fields, place the cursor under the TIC or protocol you want and press F4.

F5=MODIFY

Available when the operator has tuning authority and NTuneNCP is included. For more information, refer to Chapter 5, Using the NTuneNCP Tuning Feature.

Updates the NCP tuning parameter with the modified value. If the modification is not valid, the field turns reverse-video pink, and you are prompted to correct the value and resubmit it.

F6=ROLL

Returns to the NetView command line without exiting NTuneMON. To return to NTuneMON from the NetView program, press F6=ROLL or enter **ATUNEMON** on the NetView command line.

F7=IP DETAILS (IP over Token Ring)

Shows the ATUID IP Interface Information Detail panel, as shown on page 4-164, to show detailed information about an IP interface that is connected to this physical Token-Ring.

F8=FR/TR LINES (ALL TICs) (frame relay over Token Ring; type 1 and type 2 TICs)

Displays the ATUTF NTRI Frame Handler Logical Lines panel, as shown on page 4-291, to show information on the NTRI frame handler logical lines associated with all type 1 and type 2 TICs.

F9=ALT-PAGE

Scrolls back to the ATUTP1 Token-Ring TIC Details Page 1 panel, as shown on page 4-310, to show additional detailed information on this TIC.

F10=HEX

Displays the ATUDP Hexadecimal Storage Display panel, as shown on page 4-68, to show the physical link control block (PLB) for a type 1 or type 2 TIC, or the Token-Ring line block extension (TLB) for a type 3 TIC.

F11=ALT-PFKs

Resets the PF keys on this panel to perform their original functions as described under "PF Keys" on page 4-322.

ENTER=FR/TR LINES (frame relay over Token Ring)

Displays the ATUTF NTRI Frame Handler Logical Lines panel, as shown on page 4-291, to show information on the NTRI frame handler logical lines associated with this TIC.

F12=REFRESH/TRAFFIC RATES

Refreshes the information on this panel and displays traffic rates.

PA1=EXIT

Exits NTuneMON.

PA2=LOG

Saves the information on this panel to the NetView log.

ATUUH Cycle/Buffer Utilization History Panel

This panel has two forms:

- Figure 4-95 shows the panel that displays the cycle utilization history.
- Figure 4-96 on page 4-326 shows the panel that displays the buffer utilization history.

Basic fast-path commands: None

Tuning fields: None

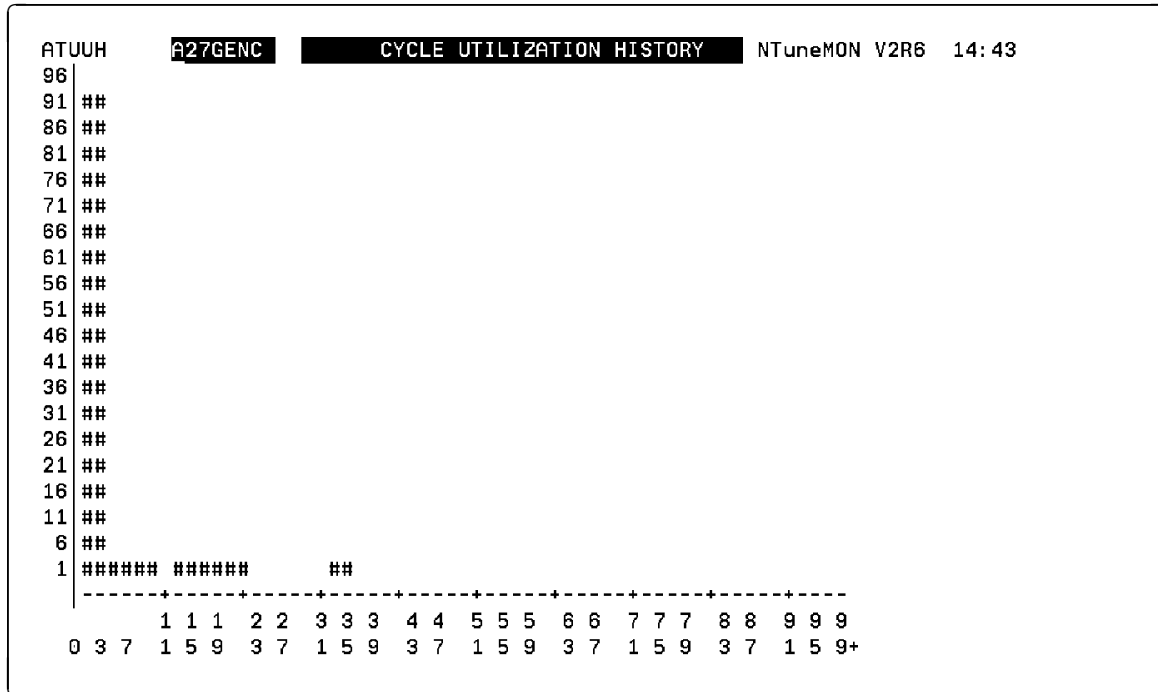

Figure 4-95. ATUUH Cycle Utilization History Panel

ATUUH Cycle/Buffer Utilization History Panel

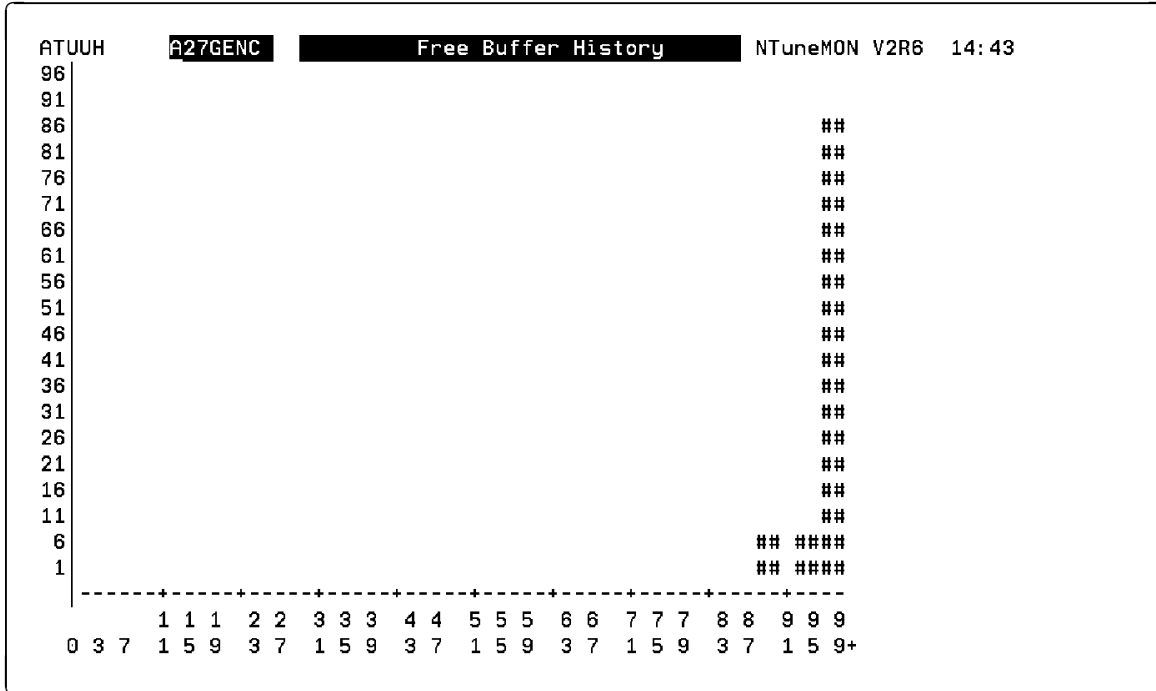

Figure 4-96. ATUUH Free Buffer History Panel

Description

The ATUUH Cycle/Buffer Utilization History panel provides a graphical display of NCP cycle and buffer usage history. This panel differs from panel ATUUT in that it displays a true representation, as opposed to a composite average, of the usage history.

To display this panel: On the ATUUT NCP Utilization panel, as shown on page 4-328, press F4 to see the cycle utilization history, or press F5 to see the buffer utilization history.

Fields

The left side of the panel is a percentage of the cycles or buffers available, depending on which is displayed. It is arranged in 5-percent steps, starting at the top with a value of 96 percent and decrementing to 1 percent at the bottom.

The rows across the bottom of the panel represent the 26 columns of the histogram, corresponding to the 26 time frames recorded. Each division across the bottom of the panel represents a 4-percent time increment.

Pound signs (##) show the numeric percentage, with the highest row of pound signs reflecting the lowest value for each column being displayed. Plus signs (++) indicate that the numeric percentage recorded in this column is less than one percent of the total available cycles or buffers. The formula to determine the percentage of each time frame is as follows: Add the values of each frame. Next use this total to determine the percentage of cycles or buffers in each of the 26 time frames.

The panel uses colors to separate the information for ease of viewing and not to reflect areas of concern.

Note: If you want to access the command line, you must return to the ATUUT panel by pressing F3.

PF Keys

Note: Although the PF key definitions are not displayed, the key functions are still active.

F1=Help

Displays online help for this panel.

F2=Toggle between Cycle Utilization and Buffer Utilization

Toggles the panel between the cycle utilization histogram and the buffer utilization histogram.

F3=Return

Returns to the previous NTuneMON panel.

F6=Roll

Returns to the NetView command line without exiting NTuneMON. To return to NTuneMON from the NetView program, press F6=ROLL or enter **ATUNEMON** on the NetView command line.

F10=Hex

Displays the ATUDP Hexadecimal Storage Display panel, as shown on page 4-68, to show the performance measurement facility (PMF) control block.

F12=Refresh

Refreshes the display with current information from PMF.

PA1=Exit

Exits NTuneMON.

PA2=Log

Saves the information on this panel to the NetView log.

ATUUT NCP Utilization Panel

Basic fast-path commands: UT, UTIL, UTILD

Tuning fields: None

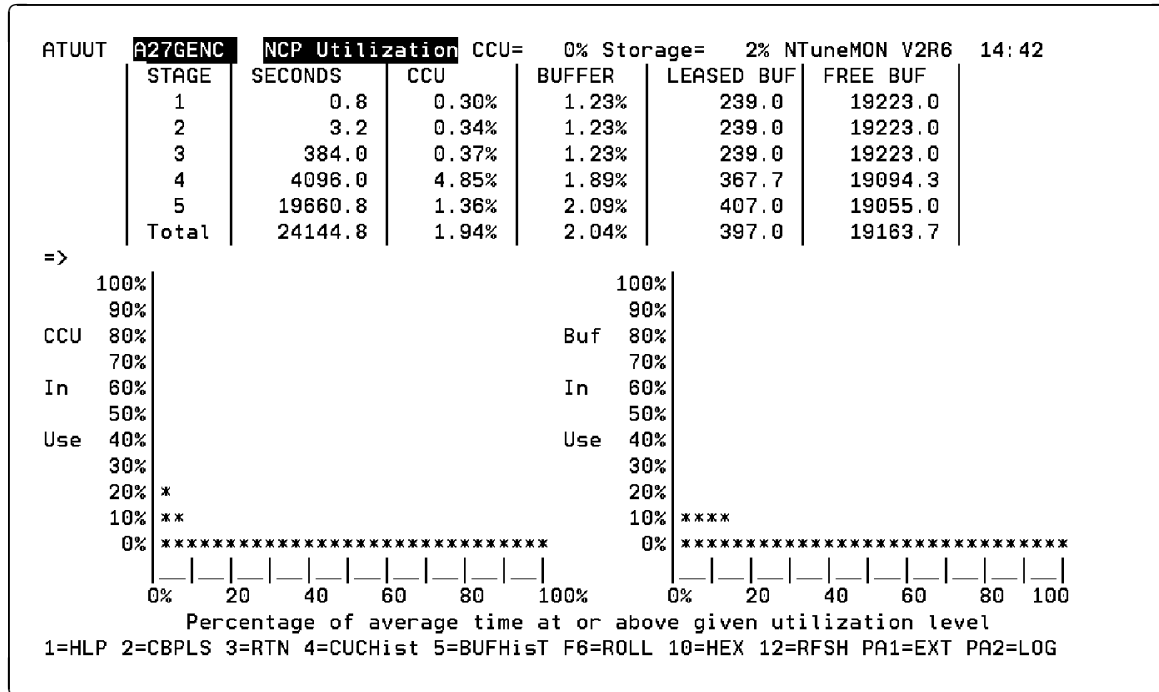

Figure 4-97. ATUUT NCP Utilization Panel

Description

The ATUUT NCP Utilization panel displays short-term and long-term NCP CCU and buffer use in numeric form. This panel also shows short-term use in graphic form.

To display this panel:

- From the first PF key selection of the ATUNP NCP Selection panel, as shown on page 4-204, press F10.
- From the third PF key selection of the ATUCD CDS NCP Selection panel, as shown on page 4-27, press F10.
- From the first PF key selection of the ATUNW NCP Wide Selection panel, as shown on page 4-212, press F10.
- From the first PF key selection of the ATUSS Summary Status panel, as shown on page 4-260, press F10.

The NCP performance measurement facility (PMF) calculates CCU and buffer use every 100 milliseconds (ms). PMF uses these values as the input to the first stage of a five-stage recursive process that calculates average use for most recent intervals of various lengths.

In this recursive process, consecutive inputs to each stage are averaged. After 16 inputs to a stage, the average for that stage is used as input to the next stage and is reset to begin another 16-input cycle. At any given time, the first stage is the average of up to sixteen 100-ms calculations (an interval of up to 1.6 seconds), the

second stage is the average of up to 16 first-stage averages (an interval of up to 25.6 seconds), and so on. The fifth stage represents an interval of up to 29 hours and 8 minutes. After this interval, PMF resets all stages to zero and begins the process again.

Figure 4-98 illustrates the smoothing effect resulting from the progressive averaging through the five stages.

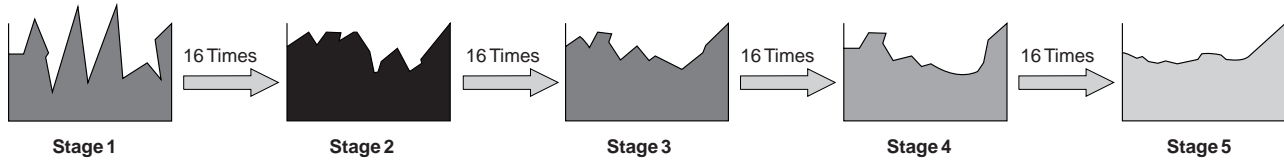

Figure 4-98. Stage Progression for the NCP CCU and Buffer Use Counter

Note: For NCP releases before NCP V6R2, the following APARS are necessary for NCP PMF to reset all stages and begin the process again.

NCP V6R1 IR98203
NCP V5R4 IR98548
NCP V4R3.1 IR98553

Fields

NCP name (second field on panel)

Name of the NCP that is currently displayed. You can enter a different NCP name in this field to display information on another NCP.

Numeric Statistics

CCU

Average CCU use during the first stage.

STORAGE

Average buffer use during the first stage.

NTuneMON displays the current average CCU and buffer use for each of the five stages in numeric form at the top of the panel.

STAGE

Calculation stage.

SECONDS

Number of seconds that have passed in each stage.

CCU

Average CCU use during each stage.

BUFFER

Average buffer use during each stage.

LEASED BUF

Average number of buffers leased during each stage.

FREE BUF

Average number of free buffers during each stage.

Histograms

NTuneMON displays the current average use for the *first stage* as a pair of histograms. The vertical axis represents CCU or buffer use as a percentage of the total available, and the horizontal axis represents the percentage of time at or above the level of use shown.

For example, if the column plotted at 60% on the horizontal axis of the CCU histogram rises to 50% on the vertical axis, this indicates that 50% or more of the CCU cycles were used 60% of the time.

PF Keys

F1=HLP

Displays online help for this panel.

F2=CBPLS

Displays the ATUCB Control Block Pools/Tables panel, as shown on page 4-17, which provides detailed information on NCP control block pools.

F3=RTN

Returns to the previous NTuneMON panel.

F4=CUCHist

Displays the ATUUH Cycle Utilization History panel, as shown on page 4-325, which provides a histogram of NCP cycle utilization.

F5=BUFHist

Displays the ATUUH Free Buffer History panel, as shown on page 4-326, which provides a histogram of NCP buffer utilization.

F6=ROLL

Returns to the NetView command line without exiting NTuneMON. To return to NTuneMON from the NetView program, press F6=ROLL or enter **ATUNEMON** on the NetView command line.

F10=HEX

Displays the ATUDP Hexadecimal Storage Display panel, as shown on page 4-68, to show the performance measurement facility (PMF) control block.

F12=RFSH

Refreshes the display with current information from PMF.

PA1=EXT

Exits NTuneMON.

PA2=LOG

Saves the information on this panel to the NetView log.

ATUVA Virtual Route Control Block Details Panel

Basic fast-path commands: None

Tuning fields: VR Window Size Max, VR Window Size Min

```

ATUVA  A27GENC  Virtual Route Control Block Details  NTuneMON V2R6  14:49

VR ID / Priority = 0.0
Network ID      = NETA      Receive Buffer Count = 0
Dest Subarea   = 1         Xmit Queue Count    = 0
VR Hop count   = 0
Next Receive Seq Number = 013A      Next Send Seq Number = 0D36

VR Window Size Max = 45      VR Piu Pool Threshold = 47
VR Window Route Size = 45    VR Piu Pool Count     = 0
VR Window Size Min = 15      VR Window Count       = 9

VR Status Information

VR Alert Information Details
VR Cong INT in Sec.= 0      VR Consg Held in SEC=0
Number of days = 0 Hour = 0 Min = 0 Sec = 0

Accum Xmit Time = 0
Forward Max Packet = 0      Receive Max Packet = 0
=>
F1=HLP F3=RTN F5=MODIF F6=ROLL F9=Alertimer F10=HEX F12=RFSH PA1=EXIT PA2=LOG
    
```

Figure 4-99. ATUVA Virtual Route Control Block Details Panel

Description

The ATUVA Virtual Route Control Block Details panel displays detailed information on a virtual route control block.

To display this panel: On the ATUVR Virtual Route panel, as shown on page 4-334, place the cursor under a virtual route and press Enter.

Fields

NCP name (second field on panel)

Name of the NCP that is currently displayed.

VR ID / Priority

Virtual route number and transmission priority. The digit before the decimal point is the virtual route number defined by the PATH statement. The digit after the decimal point is the transmission priority: 0 indicates low priority, 1 indicates medium priority, and 2 indicates high priority.

Network ID

Network name.

Dest Subarea

Subarea address at the other end of the virtual route.

VR Hop Count

Number of intermediate nodes (hops) between end points of the route.

ATUVA Virtual Route Control Block Details Panel

Receive Buffer Count

Number of receive buffers on the virtual route inbound queue.

Xmit Queue Count

Number of PIUs on the virtual route outbound queue.

Next Receive Seq Number

Hexadecimal sequence number of the next PIU to be received over this virtual route.

Next Send Seq Number

Hexadecimal sequence number of the next PIU to be sent over this virtual route.

VR Window Size Max

Maximum virtual route window size, as defined by the VRPWSnm keyword on the NCP PATH statement or by the VTAM PATH or VPATH statement.

VR Window Route Size

Current virtual route window size.

VR Window Count

Number of PIUs to be sent before a pacing response is requested.

VR Window Size Min

Minimum virtual route window size, as defined by the VRPWSnm keyword on the NCP PATH statement or by the VTAM PATH or VPATH statement.

VR PIU Pool Threshold

Incoming virtual route PIU pool threshold.

VR PIU Pool Count

Number of PIUs currently on the virtual route's incoming PIU pool.

VR Status Information

Status of the virtual route, which may be a combination of the following:

INTERNAL	The virtual route starts and ends within the same NCP and subarea. This virtual route is normally ignored.
INACTIVE	The virtual route control block (VRB) is still allocated, but the virtual route is inactive.
BLOCKED	The virtual route is congested (held condition).
CWRI	Change Window Reset Indicator (minor congestion): the receiving virtual route is directing the sending virtual route to reduce its window size by one.
RWI	Reset Window Indicator (major congestion): the receiving virtual route is directing the sending virtual route to reduce its window size to the minimum.
DISCARD	The virtual route is out of sequence and is consequently discarding inbound PIUs.
WPR	The virtual route is withholding the pacing response.

VR Alert Information Details

VR Cong INT in Sec.

Number of 10-second intervals that have passed since the VR congestion was first noticed.

Number of days

Number of half days since the congestion started.

Accum Xmit Time

Accumulated transmission time for this VR.

Forward Max Packet

Maximum forward packet size for this VR.

VR Cong Held in SEC

Number of 10-second intervals that have passed since the VR went constantly held.

Receive Max Packet

Maximum receive packet size for this VR.

PF Keys

F1=HLP

Displays online help for this panel.

F3=RTN

Returns to the previous NTuneMON panel.

F5=MODIF

Available when the operator has tuning authority and NTuneNCP is included. For more information, refer to Chapter 5, Using the NTuneNCP Tuning Feature.

Updates the NCP tuning parameter with the modified value. If the modification is not valid, the field turns reverse-video pink, and you are prompted to correct the value and resubmit it.

F6=ROLL

Returns to the NetView command line without exiting NTuneMON. To return to NTuneMON from the NetView program, press F6=ROLL or enter **ATUNEMON** on the NetView command line.

F9=Alertimer

Displays the ATUVT VR Alert Timer panel, to show the virtual route timer values for the network. Place the cursor under the name of a network and press F9.

F10=HEX

Displays the ATUDP Hexadecimal Storage Display panel, as shown on page 4-68, to show this virtual route control block (VRB).

F12=RFSH

Refreshes the information on this panel.

PA1=EXIT

Exits NTuneMON.

PA2=LOG

Saves the information on this panel to the NetView log.

ATUVR Virtual Route Panel

Basic fast-path commands: VR, VRS, VRB

Tuning fields: None

ATUVR	A27GENC	Virtual Route	OPER/MAX	VRs=	2/33	NTuneMON	V2R6	14:47		
NETWORK	SUBAREA	VR.TP	CUR	MAX	MIN	SEND	RECV	RCVDQ/LIM	XMITQ	STATE
NETA	1	0.0	45	45	15	0D34	0139	0/47	0	
NETA	27	7.2	3	5	3	018D	0000	0/9	0	INTERNAL

=> _
 F1=HELP F2=NEW_VRS F3=RETURN F6=ROLL F7=BACK F8=FWD F9=Alert Timer
 Enter=Display VRB Details F10=HEX F12=REFRESH PA1=EXIT PA2=LOG

Figure 4-100. ATUVR Virtual Route Panel

Description

The ATUVR Virtual Route panel displays information on the virtual routes (VRs) in each network.

To display this panel:

- From the first PF key selection of the ATUNP NCP Selection panel, as shown on page 4-204, press F2.
- From the third PF key selection of the ATUCD CDS NCP Selection panel, as shown on page 4-27, press F2.
- From the first PF key selection of the ATUNW NCP Wide Selection panel, as shown on page 4-212, press F2.
- From the first PF key selection of the ATUSS Summary Status panel, as shown on page 4-260, press F2.

Fields

NCP name (second field on panel)

Name of the NCP that is currently displayed. You can enter a different NCP name in this field to display information about another NCP.

OPER/MAX VRs

Number of currently operative virtual routes and maximum number of virtual routes.

The following columns on this panel show information for each network.

NETWORK

Network name.

SUBAREA

Subarea address of the other end of the virtual route.

VR.TP

Virtual route and transmission priority. The digit before the decimal point is the virtual route number defined by the PATH statement. The digit after the decimal point is the transmission priority: 0 indicates low priority, 1 indicates medium priority, and 2 indicates high priority.

CUR MAX MIN

Current, maximum, and minimum virtual route window sizes.

If the current window size reaches the maximum window size, the CUR field is highlighted in reverse-video pink and the MAX field is highlighted in reverse-video green to warn of possible performance problems.

If the current window size drops to the minimum window size, the CUR field is highlighted in reverse-video red to warn of possible congestion along the virtual route. You can ignore this condition if the minimum window size is so large that the current window size never changes.

The following are common causes of congestion:

- Exceeding the transmission group queue threshold
- Exceeding the virtual route inbound threshold
- High NCP buffer use
- High BPOOL use
- VTAM I/O buffer pool changing size rapidly

NTuneMON generates an alert (if specified) when the virtual route is congested (BLOCKED appears in the STATE column) or if the size of the virtual route inbound queue (QUEUED) exceeds the queue size limit (LIMIT).

You can use the ATUVA Virtual Route Control Block Details panel, as shown on page 4-331, to change the maximum and minimum window size.

Notes:

1. The minimum and maximum window sizes are provided by the VTAM or NCP that activates the virtual route. Consequently, this panel might display different window sizes depending upon the location of the primary end of the virtual route. To avoid this, use the same window size for both directions. For VTAM, use PATH, VPATH, or the virtual route calculation routine. For NCP, change the PATH statement and regenerate the NCP or use the VTAM dynamic NCP path update (NCPPATH). For dynamic path table updates, you need VTAM V3R2 or a later release or VTAM V4R1, and NCP V4R3.1 or later releases.
2. The default maximum window size is normally three times the hop count. For a one-hop channel route, the maximum window size might be much larger.

SEND RECV

The hexadecimal sequence numbers of the PIUs sent and received over each virtual route, or the rate at which the NCP is sending and receiving PIUs over each virtual route.

This column initially displays the current PIU sequence number. When you press ENTER or F12=REFRESH, this column displays the traffic rates in reverse-video yellow in PIUs per second (*n/S*). If the traffic rate is less than one PIU per second, NTuneMON shows the total number of PIUs sent or received (in yellow). If the traffic rate has not changed since the last refresh, NTuneMON continues to display the PIU sequence number (in turquoise).

RCVDQ/LIM

Number of PIUs on the virtual route inbound queue (RCVDQ) and the queue size limit (LIM). SNI gateway NCPs use these values to prevent inbound traffic from coming in faster than it can be sent out to other SNI networks. The queue size limit is determined internally by NCP.

If the value in this field reaches the threshold set by USER ALARM for virtual routes on the ATUSS Summary Status panel, this field is highlighted in reverse-video pink and NTuneMON issues a generic alert (if specified). You can ignore alerts for internal virtual routes.

If the inbound PIU count exceeds the queue size limit, NCP withholds the virtual route pacing response. If the inbound PIU count exceeds the queue size limit by six or more, the receiving virtual route directs the sending virtual route to reduce its window size by one (CWRI in the STATE column).

XMITQ

Number of PIUs on the virtual route outbound queue, waiting to be sent on this virtual route. If the outbound virtual route PIU pool count is non-zero, this field is highlighted in reverse-video red.

STATE

Virtual route status:

INTERNAL	The virtual route starts and ends within the same NCP and subarea. This virtual route is normally ignored.
INACTIVE	The virtual route control block (VRB) is still allocated but the virtual route is inactive. Press F2=NEW_VRS to see if this condition persists. If it does, you might eventually run out of VRBs. If this happens, contact your IBM Support Center.
BLOCKED	The virtual route is congested (held condition).
CWRI	Change Window Reset Indicator (minor congestion): the receiving virtual route is directing the sending virtual route to reduce its window size by one.
RWI	Reset Window Indicator (major congestion): the receiving virtual route is directing the sending virtual route to reduce its window size to the minimum.
DISCARD	The virtual route is out of sequence and is consequently discarding inbound PIUs.
WPR	The virtual route is withholding the pacing response.

PF Keys

F1=HELP

Displays online help for this panel.

F2=NEW_VRS

Checks for new virtual routes or virtual routes that have been deleted. This process might take an extended amount of time. It refreshes the display to show all active virtual routes. If you see an unusual state, press F2 to verify that the virtual route is still active.

F3=RETURN

Returns to the previous NTuneMON panel.

F6=ROLL

Returns to the NetView command line without exiting NTuneMON. To return to NTuneMON from the NetView program, press F6=ROLL or enter **ATUNEMON** on the NetView command line.

F7=BACK

Scrolls the panel data backward one screen.

F8=FWD

Scrolls the panel data forward one screen.

F9=Alert timer

Displays the ATUVT VR Alert Timer panel, to show the virtual route timer values for the network. Place the cursor under the name of a network and press F9.

F10=HEX

Displays the ATUDP Hexadecimal Storage Display panel, as shown on page 4-68, to show a virtual route control block (VRB). Place the cursor under the virtual route you want to view and press F10.

F12=REFRESH

Refreshes information for all virtual routes currently displayed.

ENTER=Display VRB Details

Displays the ATUVA Virtual Route Control Block Details panel, as shown on page 4-331, to show detailed information on a VRB. Place the cursor under the virtual route you want to view and press Enter.

PA1=EXIT

Exits NTuneMON.

PA2=LOG

Saves the information on this panel to the NetView log.

ATUVT VR Alert Timer Panel

Basic fast-path commands: None

Tuning fields: VR Alert Timer, VR Deact Timer, VR Transmit PIU Queue, Alert Time Limit, Deact Time Limit

```

ATUVT  A27GENC  VR Alert Timer Panel  NTuneMON V2R6  14:50

Network Name =  NETA

VR Alert for Transmission Priority 0
VR Alert Timer   =  0
VR Transmit PIU Queue =  0
VR Deact Timer   =  0

VR Alert for Transmission Priority 1
VR Alert Timer   =  0
VR Transmit PIU Queue =  0
VR Deact Timer   =  0

VR Alert for Transmission Priority 2
VR Alert Timer   =  0
VR Transmit PIU Queue =  0
VR Deact Timer   =  0

-----
TGTIMER - MLTG Performance Degraded Timer Values
Alert Time Limit   =  60
Deact Time Limit   =  0

=>
F1=HELP  F3=RETURN  F5=MODIF  F6=ROLL  F10=HEX  F12=REFRESH  PA1=EXIT  PA2=LOG
    
```

Figure 4-101. ATUVT VR Alert Timer Panel

Description

The ATUVT VR Alert Timer panel, which is available starting with NCP V7R8, enables the viewing and modification of VR timer values and TG timer values.

To display this panel:

- On the ATUNG HSCBs and GWNAUs panel, as shown on page 4-195, press F9.
- On the ATUVR Virtual Route panel, as shown on page 4-334, press F9.
- On the ATUVA Virtual Route Control Block Details panel, as shown on page 4-331, press F9.

Fields

Network Name

Name of the network, as defined by the NETID keyword on the NETWORK statement.

Virtual Routes Section

This section of the panel displays, and allows tuning of, the virtual route timer values as coded on the VRTIMERn keyword on the BUILD or NETWORK statement. There are three subsections with these fields, one subsection for each transmission priority.

VR Alert Timer

Virtual route congestion time limit, in seconds. If the virtual route is congested for this length of time, NCP sends an alert to the owning host.

VR Deact Timer

Virtual route deactivation time limit, in seconds. If the virtual route is congested for this length of time, NCP deactivates it.

VR Transmit PIU Queue

Number of PIUs that constitutes a congestion condition.

Transmission Groups Section

This section of the panel displays, and allows tuning of, the transmission group timer values as coded on the TGTIMER keyword on the BUILD or NETWORK statement.

Alert Time Limit

MLTG-performance-degraded alert time limit, in seconds. If the MLTG's performance is degraded for this length of time, then NCP sends an alert to the owning hosts.

Deact Time Limit

MLTG deactivation time limit, in seconds. If the MLTG's performance is degraded for this length of time, NCP deactivates all links in the MLTG and notifies the owners of each link.

PF Keys

F1=HELP

Displays online help for this panel.

F3=RETURN

Returns to the previous NTuneMON panel.

F5=MODIFY

Available when the operator has tuning authority and NTuneNCP is included. For more information, refer to Chapter 5, Using the NTuneNCP Tuning Feature.

Updates the NCP tuning parameter with the modified value. If the modification is not valid, the field turns reverse-video pink, and you are prompted to correct the value and resubmit it.

F6=ROLL

Returns to the NetView command line without exiting NTuneMON. To return to NTuneMON from the NetView program, press F6=ROLL or enter **ATUNEMON** on the NetView command line.

F10=HEX

Displays the ATUDP Hexadecimal Storage Display panel, as shown on page 4-68, to show the RMB control block.

ATUVT VR Alert Timer Panel

- | **F12=RFSH**
- | Refreshes the information on this panel.
- | **PA1=EXIT**
- | Exits NTuneMON.
- | **PA2=LOG**
- | Saves the information on this panel to the NetView log.

ATUXD X.25 Virtual Circuit Details Panel

This panel has two forms:

- Figure 4-102 shows the panel that displays when the virtual circuit is defined as an NPSI virtual circuit.
- Figure 4-103 on page 4-342 shows the panel that displays when the virtual circuit is defined as an X.25 ODLC virtual circuit.

Basic fast-path commands: None

Tuning fields: None

```

ATUXD  A98SVT3  X.25 Virtual Circuit Details  NTuneMON V2R2  15:17
|-----|-----|
| Physical Link | Circuit Details |
| Line Name = MCH1028 | Station Name= XPP01PVC | Status = ACTIVE |
| Line Addr = 1028 | LCG-LCN Num = 00 - 1 | Node Type = Subarea |
| Status = ACTIVE | Group Status= N/A | End User ID = LLC3 QLLC |
| Line Adapter= HPTSS | Pkt Modulo = 128 | PKT Window = 127 |
| Line Speed = N/A | VR Status = N/A | Circuit Type= PVC |
| | Call Type = N/A | VCCPT Index = 7 |
| | VCM State = P4 Data Transfer | | |
|---|---|---|---|
| Support Type | SEND | RECEIVE |
| Supported | Packet Size = 4096 | 4096 |
| | Count | SENT | RECEIVED |
| | Data Packet = 0 | 0 |
| | RR Packets = 0 | 0 |
| | RNR Packets = 0 | 0 |
|-----|-----|
=>
F1=Help  F2=VC Statistics  F3=Return  F6=Roll
F10=Hex  F12=Refresh  PA1=Exit  PA2=Log
    
```

Figure 4-102. ATUXD X.25 Virtual Circuit Details Panel for NPSI

ATUXD X.25 Virtual Circuit Details Panel

```

ATUXD  A71SDX2  X.25 Virtual Circuit Details  NTuneMON V2R2  10:46
-----
| Physical Link | Circuit Details | |
| Line Name = MCH2304 | Station Name= XPP01PVC | Status = INACTIVE |
| Line Addr = 2304 | LCG-LCN Num = 00 - 1 | Node Type = Subarea |
| Status = INACTIVE | Group Status= INACTIVE | End User ID = LLC3 QLLC |
| Line Adapter= CLP | Pkt Modulo = 128 | PKT Window = N/A |
| Line Speed = N/A | UR Status = N/A | Circuit Type= PVC |
| | Call Type = N/A | VCCPT Index = 7 |
| | UCM State = N/A | |
-----
| Support Type | SEND | RECEIVE | QLLC Retry |
| Supported | Packet Size = N/A | N/A | Timer = 30 |
| | Count SENT RECEIVED | Retry = 3 |
| LLC3 Supported | Data Packet = N/A | N/A | |
| | RR Packets = N/A | N/A | |
| | RNR Packets = N/A | N/A | |
-----
=>
F1=Help          F3=Return  F6=Roll
F10=Hex         F12=Refresh PA1=Exit  PA2=Log

```

Figure 4-103. ATUXD X.25 Virtual Circuit Details Panel for X.25 ODLC

Description

The ATUXD X.25 Virtual Circuit Details panel is available starting with:

- NCP V7R2, for NPSI X.25 resources with NPSI V3R7 or later releases
- NCP V7R4, for X.25 ODLC resources

It displays detailed information about a virtual circuit.

To display this panel: On the ATUXV X.25 Virtual Circuit List panel, as shown on page 4-366, press Enter.

Fields

NCP name (second field on panel)

Name of the NCP that is currently displayed.

Physical Link

The MCH. This includes:

Line Name

Name assigned to the MCH.

Line Addr

Address of the MCH physical line.

Status

Physical line status. This field will be one of the following:

- PEND ACTLINK** An activate link command (ACTLINK) is in progress.
- ACTIVE** An ACTLINK has been processed, and the line is active.
- PEND DACTLNK** A deactivate link command (DACTLINK) is in progress.

- INACTIVE** A DACTLINK has been processed, and the line is inactive. Inactive lines are highlighted in reverse-video red.
- FORCE DEACT** The line has been forced into deactivation. (A force deactivate command was issued from VTAM.)
- PEND ANS** Line quiescence is pending due to automatic network shutdown (ANS).

Line Adapter

Type of line adapter: HPTSS, TSS, or CLP.

Line Speed

Data rate for the line in bits per second as defined by the *rate* suboperand of the SPEED keyword on the LINE statement. This is the rate at which the devices communicate with the communication controller.

NCP V7R6 and Earlier Releases: The SPEED value displayed on this panel might differ from the rate specified for the SPEED keyword:

For TSS and HPTSS adapters with CLOCKNG=EXT, following are the displayed values for SPEED. These values are valid only for NCP V5R4 and later, running on a 3745.

50, 75, 100, 110, 134, 200, 300, 600, 1200, 2400, 4800, 9600, 19200, 38400, 55855, 245760, 1843200

If a value in the above list was specified for SPEED, the panel displays that value. If an unlisted value less than 1843200 was specified for SPEED, the panel displays the next highest listed value. For example, if 60 was specified, the panel displays 75. If a value greater than 1843200 was specified for SPEED, the panel displays 1843200.

For 3746 Model 900 lines with CLOCKNG=EXT, the value displayed for SPEED represents a range of speeds as shown in Table 4-4.

Table 4-4. SPEED Values for Virtual Circuits When CLOCKNG=EXT and VERSION<V7R7

Displayed SPEED Value	Actual Data Rate (SPEED) Values for CLOCKNG=EXT
19200	>= 600 and <= 32000
38400	> 32000 and <= 64000
256000	> 64000 and <= 256000
512000	> 256000

Circuit Details

Station Name

Station name for the virtual circuit, if available.

LCG-LCN Num

Logical channel group and channel number.

Group Status

Group status: N/A for NPSI; or ASSIGNED, ATTACHED, INACTIVE, or UNKNOWN (unable to determine status) for X.25 ODLC.

Pkt Modulo

Modulo values used for packet control.

ATUXD X.25 Virtual Circuit Details Panel

VR Status

Status of the virtual route (NPSI only): VC or blank.

Call Type

Type of switched circuit: In, Out, or InOut (NPSI only).

VCM State

Status of the NPSI virtual circuit (NPSI only): P1, P2, P4, P5, P6, or D2.

Status

Status of the logical station. This can be any of the following:

INACTIVE	Reset
XID PEND	XID pending with data
XID NODT	XID pending without data
CONT PND	Contact pending
PENDING	Contact and discontact pending
ACTIVE	Active (normal data)
DISC PND	Discontact pending
INOP PND	INOP pending
INACT PD	Free-resource operation pending
LOAD/DMP	Load/Dump/RPO active
SIM PEND	Set Initialization Mode pending
LL2 ACT	Link-level 2 active
LL2 PND	Link-level 2 pending

Node Type

Type of node: Subarea or Peripheral.

End User ID

LLC type of the end user.

PKT Window

Packet window size, if available.

Circuit Type

Type of circuit: PVC or SVC.

VCCPT Index

Index value for the VCCPT that was used for setup.

Support Type

LLC types supported on this virtual circuit. Can be left blank if the circuit is not in use.

Statistics

Packet Size

Largest allowed transmit and receive packet, if available.

Data Packet

Number of transmitted or received Information packets (NPSI only).

RR Packets

Number of transmitted or received RR packets (NPSI only).

RNR Packets

Number of transmitted or received RNR packets (NPSI only).

QLLC Retry (X.25 ODLC only)

Timer

Timer for the QLLC retries.

Retry

Count of the Number of retries.

PF Keys

F1=Help

Displays online help for this panel.

F2=VC Statistics

Displays the ATUXF NPSI Virtual Circuit Statistics panel, as shown in Figure 4-104 on page 4-346, for NPSI only, if these statistics are being collected by NPM.

F3=Return

Returns to the previous NTuneMON panel.

F6=Roll

Returns to the NetView command line without exiting NTuneMON. To return to NTuneMON from the NetView program, press F6=Roll or enter **ATUNEMON** on the NetView command line.

F10=Hex

Displays the ATUDP Hexadecimal Storage Display panel, as shown on page 4-68, to show the VCB control block for NPSI or the LKB control block for X.25 ODLC.

F12=Refresh

Refreshes the information on this panel.

PA1=Exit

Exits NTuneMON.

PA2=Log

Saves the information on this panel to the NetView log.

ATUXF NPSI Virtual Circuit Statistics Panel

Basic fast-path commands: None
 Tuning fields: None

```

ATUXF  A71PVC2  NPSI Virtual Circuit Statistics  NTuneMON V2R2  14:50
Name =  MCH256A1  Element Address =  21E

-----
I-Frames Sent      =  0
I-Frames Received =  0
Bytes Sent         =  0
Bytes Received    =  0
I-Frames ReSent   =  0
Bytes ReSent      =  0
Total Errors      =  0
Outbound Queue    =  0

Packets Sent      =  0
Packets Received  =  0
Packets Sent /D   =  0
Packets Received /D =  0
Packets Sent /M   =  0
Packets Received /M =  0

=>
F1=Help  F3=Return  F6=Roll  F10=Hex  F12=Refresh  PA1=Exit  PA2=Log
    
```

Figure 4-104. ATUXF NPSI Virtual Circuit Statistics Panel

Description

The ATUXF NPSI Virtual Circuit Statistics panel, which is available starting with NCP V7R2 for NPSI X.25 resources with NPSI V3R7 or later releases, displays X.25 NPSI virtual circuit statistics.

NPM collection on the resource must be running in order to display this panel.

To display this panel:

- On the ATUXV X.25 Virtual Circuit List panel, as shown on page 4-366, press F2.
- On the ATUXD X.25 Virtual Circuit Details panel, as shown on page 4-341, press F2.

Fields

NCP Name (second field on panel)

Name of the NCP that is currently displayed.

Name

Name of the physical MCH.

Element Address

The address used for VTAM-to-NCP communication.

I-Frames Sent

Number of I-frames sent.

I-Frames Received

Number of I-frames received.

Bytes Sent

Number of bytes sent.

Bytes Received

Number bytes received.

I-Frames ReSent

Number of I-frames re-sent.

Bytes ReSent

Number of bytes re-sent.

Total Errors

Total number of errors.

Outbound Queue

Number of packets queued to be sent.

Packets Sent

Number of packets sent.

Packets Received

Number of packets received.

Packets Sent /D

Number of packets sent /D (Delayed).

Packets Received /D

Number of packets received /D (Delayed).

Packets Sent /M

Number of packets sent /M (Message).

Packets Received /M

Number of packets received /M (Message).

PF Keys

F1=Help

Displays online help for this panel.

F3=Return

Returns to the previous NTuneMON panel.

F6=Roll

Returns to the NetView command line without exiting NTuneMON. To return to NTuneMON from the NetView program, press F6=Roll or enter **ATUNEMON** on the NetView command line.

F10=Hex

Displays the ATUDP Hexadecimal Storage Display panel, as shown on page 4-68, to show the PVP control block.

F12=Refresh

Refreshes the information on this panel.

PA1=Exit

Exits NTuneMON.

PA2=Log

Saves the information on this panel to the NetView log.

ATUXH X.25 MCH Physical Line Statistics Panel

Basic fast-path commands: None
 Tuning fields: None

```

ATUXH  A71PVC2  X.25 MCH Physical Line Statistics  NTuneMON V2R2  14:30
Name =  MCH2560  Element Address =  3

_____FRAME_LEVEL_____PACKET_LEVEL_____
I-Frames Sent      =  0      | I-Frames Sent      =  0
I-Frames Received  =  0      | I-Frames Received  =  0
Bytes Sent         =  0      | Bytes Sent         =  0
Bytes Received     =  0      | Bytes Received     =  0
I-Frames ReSent   =  0      | I-Frames ReSent   =  0
Bytes ReSent      =  0      | Bytes ReSent      =  0
I-Frames ReSent   =  0      | Outbound Queue    =  0
Bytes ReSent      =  0      | Packets Sent      =  0
RNR's Sent        =  0      | Packets Received  =  0
RNR's Received    =  0      | RNR's Pkt Sent    =  0
RR's Sent         =  0      | RNR's Pkt Received=  0
RR's Recieved     =  0      | Outbound Connect  =  0
Outbound Queue    =  0      | INbound Connect   =  0
                   | Outbound Disc     =  0
                   | Inbound Disc      =  0
                   | INN-SHM Reconnect =  0
=>
F1=Help  F3=Return  F6=Roll  F10=Hex  F12=Refresh  PA1=Exit  PA2=Log
    
```

Figure 4-105. ATUXH X.25 MCH Physical Line Statistics

Description

The ATUXH X.25 MCH Physical Line Statistics panel, which is available for NCP V7R2 or later releases, when running NPSI V3R7 or later releases, displays statistics for an X.25 NPSI multichannel (MCH) physical line. NPM collection on the resource must be running in order to display this panel.

To display this panel:

- From the ATUXL X.25 MCH Physical Line List panel, as shown on page 4-350, press F2.
- From the ATUXP X.25 MCH Physical Line Details Page 1 panel for NPSI, as shown on page 4-353, press F2.
- From the ATUXS X.25 MCH Physical Line Details Page 2 panel for NPSI, as shown on page 4-362, press F2.

Fields

NCP name (second field on panel)

Name of the NCP that is currently displayed.

Name

Name of the physical MCH.

Element Address

The address of the resource known to VTAM.

Frame Level

This is a count of:

- I-frames sent and received
- Bytes sent and received
- I-frames resent
- Bytes resent
- RNRs sent and received
- RRs sent and received
- Outbound Queue – length of the queue.

Packet Level

This is a count of:

- I-frames sent and received
- Bytes sent and received
- I-frames resent
- Bytes resent
- Outbound Queue – length of the queue
- Packets sent and received
- RNR packets sent and received
- Connect outbound and inbound
- Disconnects outbound and inbound
- INN-SHM reconnect.

PF Keys

F1=Help

Displays online help for this panel.

F3=Return

Returns to the previous NTuneMON panel.

F6=Roll

Returns to the NetView command line without exiting NTuneMON. To return to NTuneMON from the NetView program, press F6=Roll or enter **ATUNEMON** on the NetView command line.

F10=Hex

Displays the ATUDP Hexadecimal Storage Display panel, as shown on page 4-68, to show the PML control block.

F12=Refresh

Refreshes the information on this panel.

PA1=Exit

Exits NTuneMON.

PA2=Log

Saves the information on this panel to the NetView log.

ATUXL X.25 MCH Physical Line List Panel

Basic fast-path commands: NPSI (displays only NPSI lines), X25 (displays only X.25 ODLC lines), X25NPSI (displays both NPSI and X.25 ODLC lines), NPSIX25 (displays both types of lines), MCH (displays both types of lines)

Tuning fields: None

```

ATUXL  A71SOX2  X.25 MCH Physical Line List  NTuneMON V2R2    09:31
        CCU =    0                      Buffers =    1
        NPSI Version = V3R8

ADDR   NAME      Status   Type   ADDR   NAME      Status   Type
-----
2242   MCH2242      INACTIVE NPSI
1      MCH0001      ACTIVE   NPSI
2304   MCH2304      INACTIVE X.25
2240   MCH2240      INACTIVE X.25
2272   MCH2272      INACTIVE X.25

=>
F1=Help  F2= MCH Stats F3=Return  F4=NPSI Only  F5=X25 ODLC      F6=Roll
F7=Back  F8=FWD   F9=UCCPT Info  F10=Hex      F11=Virtual Circuit List
ENTER=Physical Line Detail  F12=Refresh      PA1=Exit  PA2=Log
    
```

Figure 4-106. ATUXL X.25 MCH Physical Line List Panel

Description

The ATUXL X.25 MCH Physical Line List panel is available starting with:

- NCP V7R2, for NPSI X.25 resources with NPSI V3R7 or later releases
- NCP V7R4, for X.25 ODLC resources

It displays a list of X.25 multichannel (MCH) physical lines. This panel is also the entry point to the NTuneMON support for X.25 resources. Figure 1-10 on page 1-14 shows the panel-to-panel flow within the X.25-related panels.

To display this panel:

- From PF key selection number 4 on the ATUNP NCP Selection panel, as shown on page 4-204, press F2.
- From PF key selection number 4 on the ATUNW NCP Wide Selection panel, as shown on page 4-212, press F2.
- From PF key selection number 4 on the ATUCD CDS NCP Selection panel, as shown on page 4-27, press F2.

Fields

NCP name (second field on panel)

Name of the NCP that is currently displayed.

CCU

NCP cycle utilization percentage.

Buffers

Percentage of NCP buffers in use. This figure equals (number of buffers currently in use) / (total number of buffers) * 100. The total number of buffers depends on the amount of NCP storage (the MEMSIZE keyword on the BUILD statement), the NCP load module size, and the NCP buffer size (the BFRS keyword on the BUILD statement).

NPSI Version

The version and release of NPSI, if applicable.

ADDR

The address of the line, as defined by the ADDRESS keyword on the X25.MCH statement.

NAME

The name of the physical line as defined in the NCP generation.

Status

Physical line status. This field will be one of the following:

PEND ACTLINK	An activate link command (ACTLINK) is in progress.
ACTIVE	An ACTLINK has been processed, and the line is active.
PEND DACTLNK	A deactivate link command (DACTLINK) is in progress.
INACTIVE	A DACTLINK has been processed, and the line is inactive. Inactive lines are highlighted in reverse-video red.
FORCE DEACT	The line has been forced into deactivation. (A force deactivate command was issued from VTAM.)
PEND ANS	Line quiescence is pending due to automatic network shutdown (ANS).

Type

The type of resource: either X25 (which means X.25 ODLC) or NPSI.

PF Keys

F1=Help

Displays online help for this panel.

F2=MCH Stats

Displays MCH statistics, as shown under "ATUXH X.25 MCH Physical Line Statistics Panel" on page 4-348, for NPSI only.

F3=Return

Returns to the previous NTuneMON panel.

F4=NPSI Only

Displays only NPSI physical lines.

F5=X25 ODLC

Displays only X.25 ODLC physical lines.

ATUXL X.25 MCH Physical Line List Panel

F6=Roll

Returns to the NetView command line without exiting NTuneMON. To return to NTuneMON from the NetView program, press F6=Roll or enter **ATUNEMON** on the NetView command line.

F7=Back

Scrolls the panel data backward one screen.

F8=FWD

Scrolls the panel data forward one screen.

F9=VCCPT Info

Displays virtual circuit connection parameter table (VCCPT) information, as shown under "ATUXX X.25 VCCPT Information Panel" on page 4-369.

F10=Hex

Displays the ATUDP Hexadecimal Storage Display panel, as shown on page 4-68, to show a control block. The control block is chosen as follows:

- If an NPSI MCH line is selected, display the MKB control block.
- If an X.25 ODL C MCH line is selected, display the LKB control block.
- If no MCH line is selected, display the NPSI AVT control block. If NPSI is not included, display the NCP XPT control block.

F11=Virtual Circuit List

Displays the ATUXV X.25 Virtual Circuit List, as shown on page 4-366, for the selected MCH line.

Enter=Physical Line Detail

Displays the ATUXP X.25 MCH Physical Line Details Page 1 panel, as shown on page 4-353, for the selected MCH line.

F12=Refresh

Refreshes the information on this panel.

PA1=Exit

Exits NTuneMON.

PA2=Log

Saves the information on this panel to the NetView log.

ATUXP X.25 MCH Physical Line Details Page 1 Panel

There are two forms of this panel:

- “ATUXP Panel for NPSI” describes the panel that displays when the physical line is defined as an NPSI line.
- “ATUXP Panel for X.25 ODLC” on page 4-358 describes the panel that displays when the physical line is defined as an X.25 ODLC line.

ATUXP Panel for NPSI

Basic fast-path commands: None

Tuning fields: Line Speed, NRZI, Clockng

```

ATUXP  A04S0X2  X.25 MCH Physical Line Details Pg1  NTuneMON V2R5  09:25
          CCU = 1                      Buffers = 1

|-----|
| Line Address= 2243      Line Name   = MCH2243      MCH Name   = MCH2243
| Status      = INACTIVE  Element Addr = 57          Fr Modulo  = 128
| Line Adapter= CLP       Line Speed  = 75000        Clockng    = EXT
| Frame Window= 127      NRZI       = YES           Max Frame  = 4100
|                                     Network Type = 1
| FPTI MCH   = NO        X.21 Switched= NO        Link Modulo = 128
| TP Timer   = 10        TD Timer    = 3
|-----|
| MCH Link State and Substate
| MCH Idle                                     No frames allowed
|-----|
| SYS Generated Parm List
| LAC Trace Active = YES  D bit Support = YES  Translation Type = NONE
| MCH working as  = DCE  LCN 0 Used   = NO   RNR Packet      = YES
| DM Supported    = YES  Dial-by-     = N/A  Reset PVC       = NO
| Interwork Support= NO  Packet Modulo = 128
|-----|
=>
F1=Help  F2=MCH Stat F3=Return  F5=MODIFY  F6=Roll  F10=Hex
ENTER=More details  F11=Virtual Circuit List  F12=Refresh  PA1=Exit  PA2=Log

```

Figure 4-107. ATUXP X.25 MCH Physical Line Details Page 1 Panel for NPSI

Description

The ATUXP X.25 MCH Physical Line Details Page 1 panel, which is available starting with NCP V7R2, for NPSI X.25 resources with NPSI V3R7 or later releases, displays detailed information about an X.25 NPSI multichannel (MCH) physical line.

To display this panel: On the ATUXL X.25 MCH Physical Line List panel, as shown on page 4-350, place the cursor under an NPSI MCH and press Enter.

Fields

NCP name (second field on panel)

Name of the NCP that is currently displayed.

CCU

NCP cycle utilization percentage.

Buffers

Percentage of NCP buffers in use. This figure equals (number of buffers currently in use) / (total number of buffers) * 100. The total number of buffers depends on the amount of NCP storage (the MEMSIZE keyword on the BUILD statement), the NCP load module size, and the NCP buffer size (the BFRS keyword on the BUILD statement).

Line Address

The address of the line, as defined by the ADDRESS keyword on the X25.MCH statement.

Status

Physical line status. This field will be one of the following:

PEND ACTLINK	An activate link command (ACTLINK) is in progress.
ACTIVE	An ACTLINK has been processed, and the line is active.
PEND DACTLNK	A deactivate link command (DACTLINK) is in progress.
INACTIVE	A DACTLINK has been processed, and the line is inactive. Inactive lines are highlighted in reverse-video red.
FORCE DEACT	The line has been forced into deactivation. (A force deactivate command was issued from VTAM.)
PEND ANS	Line quiescence is pending due to automatic network shutdown (ANS).

Line Adapter

The type of line adapter: TSS, HPTSS, or CSS.

Frame Window

The frame window size as defined in the NCP generation.

FTPI MCH

YES or NO to indicate whether the line supports the FTPI (Fast Transaction Processing Interface) function.

TP Timer

The TP time value in seconds.

Line Name

The NCP-generated line name.

Element Addr

The address of the resource known to VTAM.

Line Speed

Data rate for the line in bits per second as defined by the *rate* suboperand of the SPEED keyword on the LINE statement. This is the rate at which the devices communicate with the communication controller.

NCP V7R6 and Earlier Releases: The SPEED value displayed on this panel might differ from the rate specified for the SPEED keyword:

For TSS and HPTSS adapters with CLOCKNG=EXT, following are the displayed values for SPEED. These values are valid only for NCP V5R4 and later, running on a 3745.

50, 75, 100, 110, 134, 200, 300, 600, 1200, 2400, 4800, 9600,
19200, 38400, 55855, 245760, 1843200

If a value in the above list was specified for SPEED, the panel displays that value. If an unlisted value less than 1843200 was specified for SPEED, the panel displays the next highest listed value. For example, if 60 was specified, the panel displays 75. If a value greater than 1843200 was specified for SPEED, the panel displays 1843200.

For 3746 Model 900 lines with CLOCKNG=EXT, the value displayed for SPEED represents a range of speeds as shown in Table 4-5.

Table 4-5. SPEED Values for IBM 3746 Model 900 Lines When CLOCKNG=EXT and VERSION<V7R7

Displayed SPEED Value	Actual Data Rate (SPEED) Values for CLOCKNG=EXT
19200	>= 600 and <= 32000
38400	> 32000 and <= 64000
256000	> 64000 and <= 256000
512000	> 256000

NRZI (starting with NCP V7R7)

YES or NO to specify whether the data terminal equipment at the end of the NPSI line must operate in non-return-to-zero change-on-ones mode (YES) or in non-return-to-zero mode (NO). Defined by the NRZI keyword on the LINE statement.

X.21 Switched

YES or NO to indicate whether this line is an X.21 switched line, as defined by the X21SW keyword on the GROUP statement.

TD Timer

The TD time value in seconds.

MCH Name

The name of the MCH.

Fr Modulo

The frame modulo as defined in the NPSI generation.

Clockng

Whether the modem (data set) or the communication scanner for the line provides the clocking, as defined by the CLOCKNG keyword on the LINE statement. Possible **Clockng** values on this panel are:

DIR

The scanner provides clocking and propagates it to the attached DTE. The data signal received by the controller is synchronized with the controller's clock. You must use a directly attached cable.

EXT

The modem or other external source provides clocking. You can use either a directly attached cable or a modem cable.

INT

The scanner provides clocking but does not propagate it to the attached data terminal equipment (DTE). The scanner synchronizes the received data signal; a different clock is used at each end of a link. You can use either a directly attached cable (no modem) or a modem cable.

Max Frame

The maximum frame size that can be transmitted, as defined in the NCP generation.

Network Type

As defined in the NPSI generation.

Link Modulo

As defined in the NPSI generation.

MCH Link State and Substate

The link state is one of the following:

- Idle
- Enable in progress
- Enabled
- Disable in progress
- Contact in progress
- Contacted
- DSR off
- Shutdown

The link substate is one of the following:

- No frames allowed
- SABM sent
- SABM contention
- ABM information transfer
- FRMR sent
- Disc received
- Sending DISC at link setup (LAPB)
- DM(p) received at link setup
- UA transmission

Sys Generated Parm List

LAC Trace Active

YES or NO to indicate whether the line access control (LAC) internal trace is active.

MCH working as

DTE to indicate data terminal equipment or DCE to indicate data circuit-terminating equipment.

DM Supported

YES or NO to indicate whether disconnect mode (DM) is supported.

Interwork Support

YES or NO to indicate whether interwork is supported.

D bit Support

YES or NO to indicate whether D bit is supported.

LCN 0 Used

YES or NO to indicate whether LCN 0 is supported as a virtual circuit (VC).

Dial-by-

DTE, PSDN, or N/A.

Packet Modulo

128 or 8.

Translation Type

No translation (NONE), or one of the ASCII translation types: Even, Odd, Mark, Space, User1, or User2.

RNR Packet

YES or NO to indicate whether RNR packet is supported.

Reset PVC

YES or NO to indicate whether reset PVC is supported.

PF Keys**F1=Help**

Displays online help for this panel.

F2=MCH Stats

Displays MCH statistics, as shown under “ATUXH X.25 MCH Physical Line Statistics Panel” on page 4-348, for NPSI only.

F3=Return

Returns to the previous NTuneMON panel.

F5=MODIFY (starting with NCP V7R7)

Available when the operator has tuning authority and NTuneNCP is included. For more information, refer to Chapter 5, Using the NTuneNCP Tuning Feature.

Updates the NCP tuning parameter with the modified value. If the modification is not valid, the field turns reverse-video pink, and you are prompted to correct the value and resubmit it.

F6=Roll

Returns to the NetView command line without exiting NTuneMON. To return to NTuneMON from the NetView program, press F6=Roll or enter **ATUNEMON** on the NetView command line.

F10=Hex

Displays the ATUDP Hexadecimal Storage Display panel, as shown on page 4-68, to show the MKB control block.

Enter=More Details

Displays the second part of the line details, as shown under “ATUXS X.25 MCH Physical Line Details Page 2 Panel” on page 4-362.

F11=Virtual Circuit List

Displays the ATUXV X.25 Virtual Circuit List, as shown on on page 4-366, for the selected MCH.

F12=Refresh

Refreshes the information on this panel.

PA1=Exit

Exits NTuneMON.

PA2=Log

Saves the information on this panel to the NetView log.

ATUXP Panel for X.25 ODLC

Basic fast-path commands: None

Tuning fields: Line Speed, Clockng, NRZI

```

ATUXP  A04SOX2  X.25 MCH Physical Line Details Pg1  NTuneMON V2R5  09:30
        CCU = 1                               Buffers = 1

-----
Line Address= 2336      Line Name   = MCH2336
Status       = INACTIVE Element Addr = 53      Fr Modulo  = N/A
Line Adapter= CLP      Line Speed  = 1200    Clockng    = EXT
Frame Window= 127     NRZI       = NO      Max Frame  = 4103
                                     Network Type = N/A

CCITT       = 1988     PLP Modulo = 128
PLP Role    = DCE      LAPB Role  = DCE

-----

Low PVC     = 1        Low Tway CHN = 257
High PVC    = 2        High Tway CHN= 265
Low In CHN  = 0        Low Out CHN  = 0
High In CHN = 0        High Out CHN = 0

=>
F1=Help      F3=Return  F5=MODIFY  F6=Roll    F10=Hex
ENTER=More details  F11=Virtual Circuit List  F12=Refresh  PA1=Exit  PA2=Log
    
```

Figure 4-108. ATUXP X.25 MCH Physical Line Details Page 1 Panel for X.25 ODLC

Description

The ATUXP X.25 MCH Physical Line Details Page 1 panel, which is available starting with NCP V7R4 for X.25 ODLC resources, displays detailed information about an X.25 ODLC multichannel (MCH) physical line.

To display this panel: On the ATUXL X.25 MCH Physical Line List panel, as shown on page 4-350, place the cursor under an X.25 ODLC MCH and press Enter.

Fields

NCP name (second field on panel)

Name of the NCP that is currently displayed.

CCU

NCP cycle utilization percentage

Buffers

Percentage of NCP buffers in use. This figure equals (number of buffers currently in use) / (total number of buffers) * 100. The total number of buffers depends on the amount of NCP storage (the MEMSIZE keyword on the BUILD statement), the NCP load module size, and the NCP buffer size (the BFRS keyword on the BUILD statement).

Line Address

The address of the line, as defined by the ADDRESS keyword on the X25.MCH statement.

Status

Physical line status. This field will be one of the following:

- PEND ACTLINK** An activate link command (ACTLINK) is in progress.
- ACTIVE** An ACTLINK has been processed, and the line is active.
- PEND DACTLNK** A deactivate link command (DACTLINK) is in progress.
- INACTIVE** A DACTLINK has been processed, and the line is inactive. Inactive lines are highlighted in reverse-video red.
- FORCE DEACT** The line has been forced into deactivation. (A force deactivate command was issued from VTAM.)
- PEND ANS** Line quiescence is pending due to automatic network shutdown (ANS).

Line Adapter

The type of line adapter is CLP.

Frame Window

The frame window size as defined in the NCP generation.

CCITT

Defined in the NCP generation: 1980, 1984, 1988, or 1993.

PLP Role

Defined in the NCP generation: DTE, DCE, or Negot.

Line Name

The NCP-generated line name.

Element Addr

The address of the resource known to VTAM.

Line Speed

Data rate for the line in bits per second as defined by the *rate* suboperand of the SPEED keyword on the LINE statement. This is the rate at which the devices communicate with the communication controller.

NCP V7R6 and Earlier Releases: The SPEED value displayed on this panel might differ from the rate specified for the SPEED keyword:

For 3746 Model 900 lines with CLOCKNG=EXT, the value displayed for SPEED represents a range of speeds as shown in Table 4-6.

Table 4-6. SPEED Values for X.25 ODLC Lines When CLOCKNG=EXT and VERSION<V7R7

Displayed SPEED Value	Actual Data Rate (SPEED) Values for CLOCKNG=EXT
19200	>= 600 and <= 32000
38400	> 32000 and <= 64000
256000	> 64000 and <= 256000
512000	> 256000

NRZI (starting with NCP V7R7)

YES or NO to specify whether the data terminal equipment at the end of the X.25 ODLC line must operate in non-return-to-zero change-on-ones mode (YES) or in non-return-to zero mode (NO). Defined by the NRZI keyword on the LINE statement.

PLP Modulo

Defined in the NCP generation.

LAPB Role

Defined in the NCP generation: DTE, DCE or Negot.

Fr Modulo

Not applicable for X.25 ODLC.

Clockng

Whether the modem (data set) or the communication scanner for the line provides the clocking, as defined by the CLOCKNG keyword on the LINE statement.

DIR

The scanner provides clocking and propagates it to the attached DTE. The data signal received by the controller is synchronized with the controller's clock. You must use a directly attached cable.

EXT

The modem or other external source provides clocking. You can use either a directly attached cable or a modem cable.

INT

The scanner provides clocking but does not propagate it to the attached data terminal equipment (DTE). The scanner synchronizes the received data signal; a different clock is used at each end of a link. You can use either a directly attached cable (no modem) or a modem cable.

Max Frame

The maximum frame size that can be transmitted, as defined in the NCP generation.

Network Type

Not applicable for X.25 ODLC.

Low PVC

The low PVC address for this line.

High PVC

The high PVC address for this line.

Low In CHN

The lowest inbound channel allowed, or zero.

High In CHN

The highest inbound channel allowed, or zero.

Low Tway CHN

The lowest two-way channel allowed, or zero.

High Tway CHN

The highest two-way channel allowed, or zero.

Low Out CHN

The lowest outbound channel allowed, or zero.

High Out CHN

The highest outbound channel allowed, or zero.

PF Keys

F1=Help

Displays online help for this panel.

F3=Return

Returns to the previous NTuneMON panel.

F5=MODIFY (starting with NCP V7R7)

Available when the operator has tuning authority and NTuneNCP is included. For more information, refer to Chapter 5, Using the NTuneNCP Tuning Feature.

Updates the NCP tuning parameter with the modified value. If the modification is not valid, the field turns reverse-video pink, and you are prompted to correct the value and resubmit it.

F6=Roll

Returns to the NetView command line without exiting NTuneMON. To return to NTuneMON from the NetView program, press F6=ROLL or enter **ATUNEMON** on the NetView command line.

F10=Hex

Displays the ATUDP Hexadecimal Storage Display panel, as shown on page 4-68, to show the LKB control block.

Enter=More details

Displays the second part of the line details, as shown under "ATUXS X.25 MCH Physical Line Details Page 2 Panel" on page 4-362.

F11=Virtual Circuit List

Displays the ATUXV X.25 Virtual Circuit List, as shown on page 4-366, for the selected MCH.

F12=Refresh

Refreshes the information on this panel.

PA1=Exit

Exits NTuneMON.

PA2=Log

Saves the information on this panel to the NetView log.

ATUXS X.25 MCH Physical Line Details Page 2 Panel

This panel has two forms:

- Figure 4-109 shows the panel that displays when the physical line is defined as an NPSI line.
- Figure 4-110 on page 4-363 shows the panel that displays when the physical line is defined as an X.25 ODLC line.

Basic fast-path commands: None

Tuning fields: None

```

ATUXS  A98SVT3  X.25 MCH Physical Line Details Pg2  NTuneMON V2R2      14:47
-----
| Line Name   = MCH1028          Station Name = XPAB1
| Line Status = ACTIVE          Station Status = ACTIVE
-----
| Enable Timer = 30
| Disable Time = 30
| X.25 DTE Addr = 03
| X.25 DCE Addr = 01
|
| LLC3 Supported
|
| Timer Values in Seconds
| T20 Restart = 180
| T21 Call    = 200
| T22 Reset   = 180
| T23 Clear   = 180
| T25         = 0
| T26 Interrupt = 180
| Inactivity  = 0
|
| Retransmission Counts
| R20 Restart = 2
| R22 Reset   = 2
| R23 Clear   = 2
|
=>
F1=Help  F2= MCH Stats  F3=Return  F6=Roll  F10=Hex
F11=Virtual Circuit List  F12=Refresh  PA1=Exit  PA2=Log
  
```

Figure 4-109. ATUXS X.25 MCH Physical Line Details Page 2 Panel for NPSI

```

ATUXS  A7ISOX2  X.25 MCH Physical Line Details Pg2  NTuneMON V2R2  10:53
|-----|
|Line Name = MCH2304          Station Name = XPA01
|Line Status = INACTIVE      Station Status = INACTIVE
|-----|
|Enable Timer = 3            Timer Values in Seconds
|Disable Time = 3
|X.25 DTE Addr = N/A        |T20 Restart = 180
|X.25 DCE Addr = N/A        |T21 Call   = 200
|LAPB Window = 127         |T22 Reset  = 180
|                            |T23 Clear  = 180
|                            |T25        = 0
|                            |T26 Interrupt = 180
|                            |Inactivity = 600
|LLC3 Supported             |
|                            |Retransmission Counts
|                            |R20 Restart = 2
|                            |R22 Reset   = 2
|                            |R23 Clear   = 2
|-----|
=>
F1=Help      F3=Return  F6=Roll   F10=Hex
F11=Virtual Circuit List  F12=Refresh  PA1=Exit  PA2=Log
    
```

Figure 4-110. ATUXS X.25 MCH Physical Line Details Page 2 Panel for X.25 ODLC

Description

The ATUXS X.25 MCH Physical Line Details Page 2 panel is available starting with:

- NCP V7R2, for NPSI X.25 resources with NPSI V3R7 or later releases
- NCP V7R4, for X.25 ODLC resources

It displays detailed information about a multichannel (MCH) physical line.

To display this panel, press Enter on either ATUXP panel:

- The ATUXP X.25 MCH Physical Line Details Page 1 panel for NPSI, as shown on page 4-353
- The ATUXP X.25 MCH Physical Line Details Page 1 panel for X.25 ODLC, as shown on page 4-358

Fields

NCP name (second field on panel)

Name of the NCP that is currently displayed.

Line Name

Name of the MCH.

Line Status

Status of the line. This can be any of the following:

PEND ACTLINK An activate link command (ACTLINK) is in progress.

ACTIVE An ACTLINK has been processed, and the line is active.

PEND DACTLNK A deactivate link command (DACTLINK) is in progress.

INACTIVE	A DACTLINK has been processed, and the line is inactive. Inactive lines are highlighted in reverse-video red.
FORCE DEACT	The line has been forced into deactivation. (A force deactivate command was issued from VTAM.)
PEND ANS	Line quiescence is pending due to automatic network shutdown (ANS).

Station Name

Name of the station.

Station Status

Current status of the station. This can be any of the following:

ACTIVE	Active (normal data)
INACTIVE	Reset
XID PEND	XID pending with data
XID NODT	XID pending without data
CONT PND	Contact pending
DISC PND	Discontact pending
INOP PND	INOP pending
PENDING	Contact and discontact pending
LOAD/DMP	Load/Dump/RPO active
SIM PEND	Set initialization mode pending
LL2 ACT	Link-level 2 active
LL2 PND	Link-level 2 pending
INACT PD	Free-resource operation pending

Enable Timer

The Enable time-out value, in seconds, when activating a line.

Disable Time

The Disable time-out value, in seconds, when deactivating a line.

X25 DTE Addr

The DTE address.

X25 DCE Addr

The DCE address.

LAPB Window

Size of the window (X.25 ODLC only).

LLC Support Type

A list of the supported LLC types. For NPSI, it might not always be present and is control block dependent.

Timer Values in Seconds

The NPSI generation definitions, or the X.25 ODLC generation definitions, for the following timer values:

- T20 Restart
- T21 Call
- T22 Reset
- T23 Clear
- T25
- T26 Interrupt
- Inactivity

Retransmission Counts

The NPSI generation definitions, or the X.25 ODLC generation definitions, for the following retransmission counts:

- R20 Restart
- R22 Reset
- R23 Clear

PF Keys**F1=Help**

Displays online help for this panel.

F2=MCH Stats

Displays MCH statistics, as shown under "ATUXH X.25 MCH Physical Line Statistics Panel" on page 4-348, for NPSI only.

F3=Return

Returns to the previous NTuneMON panel.

F6=Roll

Returns to the NetView command line without exiting NTuneMON. To return to NTuneMON from the NetView program, press F6=Roll or enter **ATUNEMON** on the NetView command line.

F10=Hex

Displays the ATUDP Hexadecimal Storage Display panel, as shown on page 4-68, to show either the MKB control block for NPSI or the LKB control block for X.25 ODLC.

F11=Virtual Circuit List

Displays the ATUXV X.25 Virtual Circuit List, as shown on page 4-366, for the selected MCH.

F12=Refresh

Refreshes the information on this panel.

PA1=Exit

Exits NTuneMON.

PA2=Log

Saves the information on this panel to the NetView log.

ATUXV X.25 Virtual Circuit List Panel

Basic fast-path commands: None

Tuning fields: None

```

ATUXV      A71SOX2      X.25 Virtual Circuit List      NTuneMON V2R2      10:32
LCG-LCN NAME STATUS      LCG-LCN NAME      STATUS      LCG-LCN NAME      STATUS
00-1 XPP01PVC INACTIVE
00-2 XPP02PVC INACTIVE

=>
F1=Help      F3=Return F6=Roll F7=Back F8=Forward
ENTER=Virtual Circuit Details F10=Hex F12=Refresh PA1=Exit PA2=Log
    
```

Figure 4-111. ATUXV X.25 Virtual Circuit List Panel

Description

The ATUXV X.25 Virtual Circuit List panel is available starting with:

- NCP V7R2, for NPSI X.25 resources with NPSI V3R7 or later releases
- NCP V7R4, for X.25 ODLC resources

It displays a list of virtual circuits associated with an MCH.

To display this panel:

- From the ATUXL X.25 MCH Physical Line List panel, as shown on page 4-350, press F11.
- From the ATUXP X.25 MCH Physical Line Details Page 1 panel for NPSI, as shown on page 4-353, press F11.
- From the ATUXP X.25 MCH Physical Line Details Page 1 panel for X.25 ODLC, as shown on page 4-358, press F11.
- From the ATUXS X.25 MCH Physical Line Details Page 2 panel for NPSI, as shown on page 4-362, press F11.
- From the ATUXS X.25 MCH Physical Line Details Page 2 panel for X.25 ODLC, as shown on page 4-363, press F11.

Fields

NCP name (second field on panel)

Name of the NCP that is currently displayed.

LCG-LCN

Logical Channel group and Logical Channel number.

Name

One of the following:

- Unknown and Inactive: No name is assigned for this virtual circuit.
- Named and Active: This is the current name assigned to this virtual circuit.
- Named and Inactive: This is residual data from when the virtual circuit was active.

Status

Current status of the virtual circuit. This can be any of the following:

PEND ACTLINK	An activate link command (ACTLINK) is in progress.
ACTIVE	An ACTLINK has been processed, and the line is active.
PEND DACTLNK	A deactivate link command (DACTLINK) is in progress.
INACTIVE	A DACTLINK has been processed, and the line is inactive. Inactive lines are highlighted in reverse-video red.
FORCE DEACT	The line has been forced into deactivation. (A force deactivate command was issued from VTAM.)
PEND ANS	Line quiescence is pending due to automatic network shutdown (ANS).

PF Keys

F1=Help

Displays online help for this panel.

F2=VC Statistics

Displays the ATUXF NPSI Virtual Circuit Statistics panel, as shown on page 4-346, for NPSI only, if these statistics are being collected by NPM.

F3=Return

Returns to the previous NTuneMON panel.

F6=Roll

Returns to the NetView command line without exiting NTuneMON. To return to NTuneMON from the NetView program, press F6=Roll or enter **ATUNEMON** on the NetView command line.

F7=Back

Scrolls the panel data backward one screen.

F8=Fwd

Scrolls the panel data forward one screen.

Enter=Virtual Circuit Details

Displays the ATUXD X.25 Virtual Circuit Details panel, as shown in Figure 4-102 on page 4-341 and Figure 4-103 on page 4-342, for the selected VC.

ATUXV X.25 Virtual Circuit List Panel

F10=Hex

Displays the ATUDP Hexadecimal Storage Display panel, as shown on page 4-68, to show the VCB control block for NPSI, or the LKB control block for X.25 ODLC.

F12=Refresh

Refreshes the information on this panel.

PA1=Exit

Exits NTuneMON.

PA2=Log

Saves the information on this panel to the NetView log.

ATUXX X.25 VCCPT Information Panel

Basic fast-path commands: None

Tuning fields: None

```

ATUXX  A71SOX2  X.25 VCCPT Information  NTuneMON V2R2  09:54

Number of VCCPT      = 7                Display VCCPT Index = 1
Def Out Window Size= 127                Longest PIU Size =  N/A
Def In Window Size  = 127
Def Out Packet Size= 4096
Def In Packet Size  = 4096
Buffer Safe/Unsafe Threshold = 2841    Current Free Buffers = 45443
Buffer Unsafe/Danger Threshold = 710    Buffer Slowdown Cnt = 5683

=>
F1=Help  F2=Buffer Pool  F3=Return  F6=Roll  F10=Hex  F12=Refresh
Enter = Next VCCPT  PA1=Exit  PA2=Log

```

Figure 4-112. ATUXX X.25 VCCPT Information Panel

Description

The ATUXX X.25 VCCPT Information panel is available starting with:

- NCP V7R2, for NPSI X.25 resources with NPSI V3R7 or later releases
- NCP V7R4, for X.25 ODLG resources

It displays information from one VCCPT entry in the VCCPT control block.

To display this panel: On the ATUXX X.25 MCH Physical Line List panel, as shown on page 4-350, press F9.

Fields

NCP name (second field on panel)

Name of the NCP that is currently displayed.

Number of VCCPT

The number of entries in the VCCPT table.

Def Out Window Size

Default outbound window size if not indicated.

Def In Window Size

Default inbound window size if not indicated. N/A for NPSI.

Def Out Packet Size

Default outbound packet size if not indicated.

Def In Packet Size

Default inbound packet size if not indicated. N/A for NPSI.

ATUXX X.25 VCCPT Information Panel

Buffer Safe/Unsafe Threshold

Threshold to indicate a buffer problem.

Buffer Unsafe/Danger Threshold

Threshold to indicate a severe buffer problem.

Display VCCPT Index

Current displayed VCCPT.

Longest PIU Size

Largest PIU size from the AVT control block (NPSI only).

Current Free Buffers

Current number of free buffers.

Buffer Slowdown Cnt

Current slowdown value.

PF Keys

F1=Help

Displays online help for this panel.

F2=Buffer Pool

Displays the ATUBP NCP Buffer Pool panel, as shown on page 4-4, to show information about NCP buffer pool usage.

F3=Return

Returns to the previous NTuneMON panel.

F6=Roll

Returns to the NetView command line without exiting NTuneMON. To return to NTuneMON from the NetView program, press F6=Roll or enter **ATUNEMON** on the NetView command line.

F10=Hex

Displays the ATUDP Hexadecimal Storage Display panel, as shown on page 4-68, to show the VCCPT control block.

F12=Refresh

Refreshes the information on this panel.

Enter=Next VCCPT

Displays the next VCCPT entry.

PA1=Exit

Exits NTuneMON.

PA2=Log

Saves the information on this panel to the NetView log.

Chapter 5. Using the NTuneNCP Tuning Feature

Introducing NTuneNCP	5-3
Generating NCP for Tuning with NTuneNCP	5-4
Authorizing NTuneMON Users to NTuneNCP	5-6
Tuning Your Network Using NTuneNCP	5-6

This part of the *NTuneMON User's Guide* discusses how the NTuneNCP tuning feature, along with NTuneMON, allows you to interactively tune internal NCP resources. The following topics are covered in this chapter:

- Introducing NTuneNCP
- Generating NCP for Tuning with NTuneNCP
- Authorizing NTuneMON Users to NTuneNCP
- Tuning Your Network Using NTuneNCP

Introducing NTuneNCP

NTuneNCP is the optional tuning feature of NTuneMON that allows you to tune your active NCPs. NTuneMON, with the NTuneNCP tuning feature, provides interactive tuning capability of internal NCP resources. This capability enables you to tune your NCP without regenerating or reloading it. Figure 5-1 shows the location of NTuneNCP and NTuneMON in the Network.

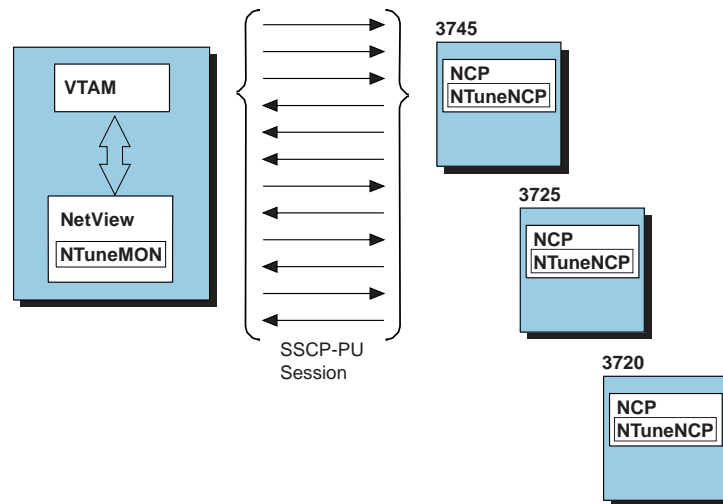

Figure 5-1. Location of NTuneNCP and NTuneMON in the Network

Using interactive NTuneMON panels, you can modify values of key NCP parameters while the NCP is running. NTuneMON issues MODIFY QUERY commands to VTAM containing a request to change the values of the NCP parameters you specified. Once modified, the new values can be used for as long as your NCP is not regenerated or reloaded.

NTuneMON with NTuneNCP provides online interactive tuning capability for virtual routes, buffer pools, HPR, frame-relay terminating equipment, frame-relay switching equipment, frame-relay physical lines, multilink transmission groups, SDLC physical lines, SDLC stations, Token-Ring stations, Token-Ring TICs, NTRI frame handler logical lines, snap traces, and data collection.

Hardware Requirements

NTuneNCP must reside with NCP in a 3725, 3720, or 3745 communications controller.

Generating NCP for Tuning with NTuneNCP

Software Requirements

To use NTuneNCP, you need the following software:

Any of the following VTAM releases:

- OS/390 Version 1 or higher
- VTAM V4R2 for VM/ESA
- VTAM V4R2 or higher for MVS/ESA
- VTAM V4R1 for MVS/ESA (with the required maintenance)
- VTAM V3R4.2 for MVS/ESA (with the required maintenance)
- VTAM V3R4.1 for MVS/ESA (with the required maintenance)

Note: To support modifying VTAM USE, you need VTAM V4R2 with the appropriate maintenance.

An MVS or VM release of NCP V4R3.1 or later.

Special Requirements for Modifying NCP Tuning Parameters

Release Requirements: Refer to Table 5-1 on page 5-7 for the level of NCP required to modify NCP tuning parameters.

Inactive Line or Station: Some NCP tuning parameters require that the line or station be inactive to modify the parameter. To modify these parameters the following conditions must be met:

- *The VTAM host in which NTuneMON is running must have the capability to deactivate the line or station.*
- *The NTuneMON user must have the authority to deactivate the line or station.*

To deactivate the resource, authorized users can issue the appropriate command on the NTuneMON command line or the NetView command line.

Ensure that NetView security measures (**span of control** and **scope of commands**) do not restrict your capability to deactivate resources.

For additional information about NetView security measures and deactivating a line or station, refer to the following publications:

- *TME 10 NetView for OS/390 Installation and Administration Guide*
- *TME 10 NetView for OS/390 Command Reference*
- *TME 10 NetView for OS/390 User's Guide*
- *VTAM Operation*

Generating NCP for Tuning with NTuneNCP

Before NCP V7R6 and NTuneMON V2R4, you must install NTuneNCP before you can generate an NCP that can be tuned. For information on installing NTuneNCP, refer to the *NTuneMON Program Directory* for the appropriate release. Beginning with NCP V7R6 and NTuneMON V2R4, the installation step is no longer needed.

Note: The NTuneNCP feature still remains a priced feature of NTuneMON. This feature must be licensed for every NCP image (one for each 37xx) that will be tuned. The tuning feature may not be turned on via the USERGEN=ATFTUN keyword on the OPTIONS statement without properly licensing the product.

Once NTuneNCP is licensed (and, for NCP V7R5 and earlier, installed) make the following updates to NCP definition statements to include NTuneNCP in your NCP generation.

- **OPTIONS Statement:** If the first executable statement of your NCP generation definition is not an OPTIONS statement, code one at the very beginning of the generation definition. On this OPTIONS statement code:

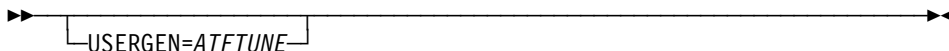

- **BUILD Statement:** For all releases except NCP V4R3.1, you must code the ATF.USGTIER keyword on the BUILD statement. The value of ATF.USGTIER must be equal to or greater than the value of the USGTIER keyword on the BUILD statement, which specifies the usage tier for the NCP. ATF.USGTIER parameters identify the tier level for NTuneMON.

The syntax for ATF.USGTIER follows:

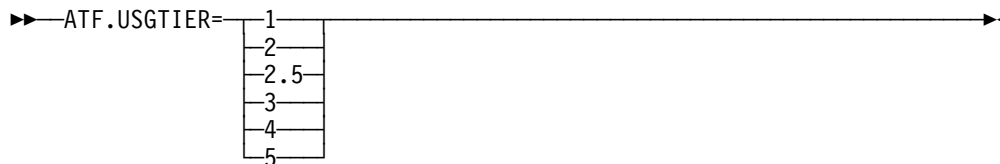

The following changes must be made to your NCP generation JCL or VM EXEC when you generate an NCP that includes NTuneNCP. Note that because the NTuneNCP object modules have been installed into the NCP object library, only the NDF portion of your JCL or VM EXEC needs to be modified. Also note that when you migrate from one NCP release to NCP V7R5 or earlier, you will need to do one of the following:

- Reinstall the NTuneNCP tuning feature into the NCP libraries of your new NCP (ANCPMOD1 and SNCPMOD1).
- Concatenate your old NCP's SNCPMOD1 library under your new NCP's SNCPMOD1 library when you generate your NCP.

MVS

To make these changes in your NCP generation JCL for MVS, concatenate the SATFMOD1 dataset to the STEPLIB dataset as shown:

```
//STEPLIB DD DSN=SYS1.SSPLIB,DISP=SHR
//          DD DSN=SYS1.SATFMOD1,DISP=SHR
```

VM

In your VM generation EXEC, include the GLOBAL LOADLIB command identifying the library containing a user-written generation load module and concatenate it with NCP as shown in this example:

```
'GLOBAL LOADLIB ATFTUNE'
'FILEFED SNCPMOD1 DISK SNETMOD1 TXTLIB * (CONCAT
```

Tuning Your Network Using NTuneNCP

Storage Requirements

NCP requires 12,280 bytes of additional storage when you include NTuneNCP.

For further software requirements information for NTuneNCP, refer to the *NTuneMON Program Directory* for your operating system.

Authorizing NTuneMON Users to NTuneNCP

It is recommended that you limit the number of NTuneNCP users to a subset of users of NTuneMON to prevent unauthorized altering of NCP parameters. The ATUNELST CLIST identifies users of NTuneMON, and, when it is included, NTuneNCP. By adding the operator identifier to the ATUNELST CLIST, you can authorize selected users to monitor the network and also change NCP tuning parameters to improve network performance.

Attention: The default in the ATUNELST CLIST is *ALL*, which gives all NTuneMON users access to NTuneNCP.

Refer to “Authorizing NTuneNCP Users to NTuneMON” on page 2-9 for additional information.

Tuning Your Network Using NTuneNCP

This section provides a general description of how to use NTuneNCP to tune your network. The following topics are covered:

- Using NTuneMON Tuning panels
- Identifying and Analyzing Network Problems Using NTuneMON
- Implementing Tuning Changes
- Submitting the Tuning Request
- Verifying Tuning Changes for ATUSP1 and ATUSP2
- Submitting the Tuning Request for ATUSP1 and ATUSP2
- Making Changes Permanent

Attention: Do NOT reload the NCP with a new load module while tuning NCP parameters. If the NCP has been reloaded, display the NCP Selection Panel (ATUNP) and press PF12 to refresh the data.

Using NTuneMON Tuning Panels

NTuneNCP receives tuning input from fields on some of the NTuneMON panels. These fields correspond to keywords and sometimes suboperands of keywords, on various definition statements.

The following table identifies NCP tuning parameters, the minimum NCP release required to modify the parameter, and the NTuneMON panel where the parameter can be modified.

Table 5-1 (Page 1 of 8). Keywords Used for Tuning

Keyword(subop- erand)	Minimum NCP Release	Tuning Field	NTuneMON Panel (Page Number)	
ACTIVTO	GROUP	V7R2	ACTIVTO	ATUSP2 SDLC Peripheral Line Parameters Page 2 (page 6-134)
ADDR	PU	V7R5	DSAP T/R Address	ATUTL Token-Ring SNA Station (page 6-156)
ADPLIMIT	BUILD	V7R8	Subarea Stage Rex Stage	ATUHP HPR & Other Global Flow Control Parm (page 6-84)
ADDR	PU	V7R5	MAC Address	ATUTD NTRI Frame Handlers Logical Line Details (page 6-152)
ANSTONE	LINE	V4R3.1 - ATUSP1 V7R6 - ATUFP2	ANSTONE	ATUSP1 SDLC Peripheral Line Parameters Page 1 (page 6-122) ATUFP2 Frame Relay Details Page 2 (page 6-48)
ARPTAB	PU	V7R1	ARP Address Format	ATUID IP Interface Information Detail (page 6-90)
BALANCE	GROUP LINE	V7R6	Conn Bal Fact	ATUTP1 Token-Ring TIC Details Page 1 (page 4-310)
BALANCE	DLCI	V7R7	Bal Factor	ATUFD Frame Relay DLCI to Balance Table (page 6-29)
BLOCK(<i>bytes</i>)	PU	V5R4 - ATUSD V6R2 - ATUFT1, ATUTL	BLOCK Gen	ATUSD SDLC Station Details (page 6-113) ATUTL Token-Ring SNA Station (page 6-156) ATUFT1 Frame Relay Terminating Equipment Details Page 1 (page 6-64)
BLOCK(<i>pius</i>)	PU	V5R4	#PIUs/BLOCK	ATUSD SDLC Station Details (page 6-113)
BLOCK(<i>pius</i>)	PU	V6R2	#PIUs/BLOCK	ATUTL Token-Ring SNA Station (page 6-156) ATUFT1 Frame Relay Terminating Equipment Details Page 1 (page 6-64)
CCLID	LINE	V4R3.1	CCLID	ATUSP1 SDLC Peripheral Line Parameters Page 1 (page 6-122)
CIR(<i>Bc,Be,Tc</i>)	DLCI	V7R7	Bc, Be, Tc	ATUFB Frame Relay DLCI CIR Parameters (page 6-26)
CIR(<i>, precision, mir%, period</i>)	LINE	V7R7	CIR, PRECISION, MIR Per, PER CIR, MIR, PRE, PER	ATUFP3 Frame Relay Details Page 3 (page 6-53) ATUDK ISDN Physical Line Details (page 4-49)
CLLM(<i>, Ty</i>)	LINE	V7R7	CLLM, Ty	ATUFP3 Frame Relay Details Page 3 (page 6-53)

Table 5-1 (Page 2 of 8). Keywords Used for Tuning

Keyword(subop- erand)	Minimum NCP Release	Tuning Field	NTuneMON Panel (Page Number)	
CLOCKNG	LINE	V4R3.1	CLOCKNG	ATUSP1 SDLC Peripheral Line Parameters Page 1 (page 6-122) ATUPL SDLC Physical Line Details (page 6-102) ATUXP X.25 MCH Physical Line Details Page 1 (page 6-189)
COMRATE (FULL NONE)	LINE	V6R2	COMRATE	ATUFT1 Frame Relay Terminating Equipment Details Page 1 (page 6-64) ATUFT2 Frame Relay Terminating Equipment Details Page 2 (page 6-78)
COMRATE(priority)	PU	V7R2	COMRATE(priority)	ATUFS1 Frame Relay Switching Equipment Page 1 (page 6-61) ATUTP2 Token-Ring TIC Details Page 2 (page 6-178) ATUFT1 Frame Relay Terminating Equipment Details Page 1 (page 6-64) ATUFT2 Frame Relay Terminating Equipment Details Page 2 (page 6-78)
COMRATE(priority)	LINE	V7R3	COMRATE(priority)	ATUTD NTRI Frame Handlers Logical Line Details (page 6-152)
CRATEDLY	LINE	V7R6	CRATEDLY	ATUFP3 Frame Relay Details Page 3 (page 4-122) ATUDK2 ISDN Physical Line Details Page 2 (page 4-55)
DATRATE	LINE	V4R3.1	DATRATE	ATUSP1 SDLC Peripheral Line Parameters Page 1 (page 6-122)
DSCRDDLY	LINE	V7R6	DSCRDDLY	ATUFP3 Frame Relay Details Page 3 (page 4-122) ATUDK2 ISDN Physical Line Details Page 2 (page 4-55)
DUPLEX	LINE	V4R3.1	DUPLEX	ATUSP1 SDLC Peripheral Line Parameters Page 1 (page 6-122)
DYNPOOL	BUILD	V7R1	DYNPOOL TOTAL ALERT% ALERT CNT TSLOW% TSLOW CNT	ATUBP NCP Buffer Pool (page 6-4)
DYNWIND(nw,dw,dwc)	LINE	V7R1 (nw) V7R8 (dw, dwc)	DYNWIND(nw) DYNWIND(dw) DYNWIND(dwc)	ATUTL Token-Ring SNA Station (page 6-156) ATUTP1 Token-Ring TIC Details Page 1 (page 6-170)

Table 5-1 (Page 3 of 8). Keywords Used for Tuning

Keyword(subop- erand)	Minimum NCP Release	Tuning Field	NTuneMON Panel (Page Number)	
DYNWIND(<i>nw, dw, dwc</i>)	PU	V7R3 - ATUTL (<i>nw</i>) V7R5 - ATUTP1 (<i>nw</i>) V7R8 (<i>dw, dwc</i>)	DYNWIND(<i>nw</i>) DYNWIND(<i>dw</i>) DYNWIND(<i>dwc</i>)	ATUTL Token-Ring SNA Station (page 6-156) ATUTP1 Token-Ring TIC Details Page 1 (page 6-170)
DYNWIND(<i>nw, dw, dwc, dwdmax, twcuse, mww</i>)	LINE	V7R1 - (<i>nw, dw, dwc</i>) V7R5 - (<i>dwdmax, twcuse</i>) V7R8 - (<i>mww</i>)	DYNWIND(<i>nw</i>) DYNWIND(<i>dw</i>) DYNWIND(<i>dwc</i>) DYNWIND(<i>dwd</i>) DYNWIND(<i>twc</i>) DYNWIND(<i>mww</i>)	ATUFP Frame Relay Physical Line Details Page 1 (page 6-34) ATUFT1 Frame Relay Terminating Equipment Details Page 1 (page 6-64)
DYNWIND(<i>nw, dw, dwc, dwdmax, twcuse, mww</i>)	PU	V7R5 - ATUFP V7R3 - ATUFT1 (<i>nw, dw, dwc</i>) V7R5 - ATUFT1 (<i>dwdmax, twcuse</i>) V7R8 - (<i>mww</i>)	DYNWIND(<i>nw</i>) DYNWIND(<i>dw</i>) DYNWIND(<i>dwc</i>) DYNWIND(<i>dwd</i>) DYNWIND(<i>twc</i>) DYNWIND(<i>mww</i>)	ATUFP Frame Relay Physical Line Details Page 1 (page 6-34) ATUFT1 Frame Relay Terminating Equipment Details Page 1 (page 6-64)
ERn(<i>lothresh, medthresh, hiithresh, tothresh</i>)	PATH	V4R3.1	LOW MED HIGH TOTAL	ATUML Multi-Link Transmission Group (page 6-93)
ERn(<i>totthresh</i>)	PATH	V7R3	QUED LMT	ATUML Multi-Link Transmission Group (page 6-93)
ETRATIO	LINE	V7R2	ETRATIO	ATUSP2 SDLC Peripheral Line Parameters Page 2 (page 6-134)
FRRATES	PU	V7R6	COMRATE	ATUFP2 Frame Relay Details Page 2 (page 4-117)
FRSPRI	LINE	V7R6	FRSPRI	ATUFP3 Frame Relay Details Page 3 (page 4-122) ATUDK2 ISDN Physical Line Details Page 2 (page 4-55)
FRSPRI	PU	V7R6	SERVICE PRIORITY	ATUFT1 Frame Relay Terminating Equipment Details Page 1 (page 4-135)
FRSPRI	PU	V7R6	SERVICE PRI	ATUFS1 Frame Relay Switching Equipment Page 1 (page 4-127)
FRSPRI	PU	V7R6	Station PRI	ATUDT ISDN Station Details (page 4-73)
GWPACING	BUILD NETWORK	V7R1	GWPACING	ATUGP Network CB Pools/Tables (page 6-81)
HDXSP	LINE	V4R3.1	HDXSP	ATUSP2 SDLC Peripheral Line Parameters Page 2 (page 6-134)

Table 5-1 (Page 4 of 8). Keywords Used for Tuning

Keyword(subop- erand)	Minimum NCP Release	Tuning Field	NTuneMON Panel (Page Number)	
HISPEED	LINE	V4R3.1	HISPEED	ATUPL SDLC Physical Line Details (page 6-102) ATUSP1 SDLC Peripheral Line Parameters Page 1 (page 6-122)
HLOQSTOP	LINE	V7R6	HLOQSTOP	ATUFP3 Frame Relay Details Page 3 (page 4-122) ATUDK2 ISDN Physical Line Details Page 2 (page 4-55)
HPRATT	BUILD	V7R3	HPRSATT	ATUHP HPR & Other Global Flow Control Params (page 6-84)
HPRMLC	BUILD	V7R3	HPRSMMLC	ATUHP HPR & Other Global Flow Control Params (page 6-84)
HPRMPS	BUILD	V7R3	HPRSMPS	ATUHP HPR & Other Global Flow Control Params (page 6-84)
HPRQLIM	PU	V7R3	HPRQLIMIT	ATUSD SDLC Station Details (page 6-113)
HPRSNAP	BUILD	V7R4	HPR NLP ROUTE SNAP TRACE ENABLED, HPR ROUTE SETUP SNAP TRACE ENABLED	ATUST NCP Function Activation (page 4-269)
IPPOOL	BUILD	V6R1	IPPOOL TOTAL	ATUBP NCP Buffer Pool (page 6-4)
IPQLIM	PU	V7R7	OUTBOUND QUEUE SIZE Maximum	ATUFI Frame-Relay IP Link Statistics (page 6-32)
IPSNAP	BUILD	V7R1	IP DATAGRAM SNAP TRACE ENABLED IP ROUTE SNAP TRACE ENABLED	ATUST NCP Function Activation (page 6-147)
LMI	PU	V6R2	LMI	ATUFP Frame Relay Physical Line Details Page 1 (page 6-34)
LMI	PU	V7R3	LMI	ATUTD NTRI Frame Handlers Logical Line Details (page 6-152)
LOCADD	LINE	V7R5	T/R LOCADD	ATUTP1 Token-Ring TIC Details Page 1 (page 4-310)
LOCALTO or T1TIMER(<i>localt1</i>)	LINE	V5R4	T1LOC	ATUTL Token-Ring SNA Station (page 6-156)

Table 5-1 (Page 5 of 8). Keywords Used for Tuning

Keyword(subop- erand)	Minimum NCP Release	Tuning Field	NTuneMON Panel (Page Number)	
LOCALTO or T1TIMER(<i>localt1</i>)	LINE	V6R2	T1 TIMER	ATUFT1 Frame Relay Terminating Equipment Details Page 1 (page 6-64)
LSPRI	LINE	V4R3.1	LSPRI	ATUPL SDLC Physical Line Details (page 6-102) ATUSP2 SDLC Peripheral Line Parameters Page 2 (page 6-134)
MAXDATA	PU	V5R4 - ATUSD V6R2 - ATUFT1, ATUTL	MAXDATA Gen	ATUTL Token-Ring SNA Station (page 6-156) ATUSD SDLC Station Details (page 6-113) ATUFT1 Frame Relay Terminating Equipment Details Page 1 (page 6-64)
MAXOUT	PU SDLCST	V4R3.1 - ATUSD V5R4 - ATUTL V6R2 - ATUFT1	MAXOUT Gen	ATUSD SDLC Station Details (page 6-113) ATUTL Token-Ring SNA Station (page 6-156) ATUFT1 Frame Relay Terminating Equipment Details Page 1 (page 6-64)
MLTGPRI	LINE	V6R1	PRI	ATUML Multi-Link Transmission Group (page 6-93)
MODULO	PU	V4R3.1	Indirectly via MAXOUT GEN	ATUSD SDLC Station Details (page 6-113)
NCPTRACE	BUILD	V6R1	NTRI/FRAME RELAY SNAPTRACE ENABLED	ATUST NCP Function Activation (page 6-147)
NEWSYNC	LINE	V4R3.1	NEWSYNC	ATUSP1 SDLC Peripheral Line Parameters Page 1 (page 6-122)
NRZI	LINE	V4R3.1 - ATUPL, ATUSP1 V6R2 - ATUFP	NRZI	ATUPL SDLC Physical Line Details (page 6-102) ATUSP1 SDLC Peripheral Line Parameters Page 1 (page 6-122) ATUFP Frame Relay Physical Line Details Page 1 (page 6-34)
NTUNECOL	BUILD	V7R2	NTUNECOL	ATUST NCP Function Activation (page 6-147)
PASSLIM	PU SDLCST	V4R3.1	PASSLIM Cur PASSLIM Gen	ATUSD SDLC Station Details (page 6-113)
PAUSE	LINE SDLCST	V4R3.1	PAUSE	ATUPL SDLC Physical Line Details (page 6-102) ATUSP2 SDLC Peripheral Line Parameters Page 2 (page 6-134)
PIUCHECK	PU	V7R7	PIUCHECK GEN	ATUDT ISDN Station Details (page 6-24) ATUFT1 Frame Relay Terminating Equipment Details Page 1 (page 6-64) ATUSD SDLC Station Details (page 6-113) ATUTL Token-Ring SNA Station (page 6-156)

Table 5-1 (Page 6 of 8). Keywords Used for Tuning

Keyword(subop- erand)	Minimum NCP Release	Tuning Field	NTuneMON Panel (Page Number)	
QSIZE	LINE	V7R6	QSIZE	ATUFP3 Frame Relay Details Page 3 (page 4-122) ATUDK2 ISDN Physical Line Details Page 2 (page 4-55)
QSIZEDE	LINE	V7R6	QSIZEDE	ATUFP3 Frame Relay Details Page 3 (page 4-122) ATUDK2 ISDN Physical Line Details Page 2 (page 4-55)
QSZALERT	BUILD	V7R6	THRESHLD1 THRESHLD2 ACTION	ATUBP NCP Buffer Pool (page 6-4)
REDIAL(,t1,n,t2)	LINE	V4R3.1 - ATUSP2 V7R6 - ATUFP2	REDIAL	ATUSP2 SDLC Peripheral Line Parameters Page 2 (page 6-134) ATUFP2 Frame Relay Details Page 2 (page 6-48)
REMOTTO or T1TIMER(remott1)	LINE	V5R4	T1REM	ATUTL Token-Ring SNA Station (page 6-156)
REPLYTO	GROUP	V7R2	REPLYTO	ATUSP2 SDLC Peripheral Line Parameters Page 2 (page 6-134) ATUMT Modify Timer Value (page 6-97)
RETRIES(m)	LINE	V7R5	Receive Errors THRESH	ATUFP Frame Relay Physical Line Details Page 1 (page 4-108)
RETRIES(m,t,n)	LINE	V4R3.1 - (m) V6R2 - (t,n)	RETRIES	ATUSP2 SDLC Peripheral Line Parameters Page 2 (page 6-134)
RETRIES(, t,n)	PU	V4R3.1	RETRIES	ATUSD SDLC Station Details (page 6-113)
RETRYTO	GROUP	V7R2	RETRYTO	ATUSP2 SDLC Peripheral Line Parameters Page 2 (page 6-134) ATUMT Modify Timer Value (page 6-97)
RING	LINE	V4R3.1 - ATUSP1 V7R6 - ATUFP2	RING	ATUSP1 SDLC Peripheral Line Parameters Page 1 (page 6-122) ATUFP2 Frame Relay Details Page 2 (page 6-48)
RNRLIMIT	GROUP	V7R2	RNRLIMIT	ATUSP2 SDLC Peripheral Line Parameters Page 2 (page 6-134)
SERVLIM	LINE SDLCST	V4R3.1	SERVLIM	ATUPL SDLC Physical Line Details (page 6-102) ATUSP2 SDLC Peripheral Line Parameters Page 2 (page 6-134)
SPEED	LINE	V4R3.1	SPEED	ATUSP1 SDLC Peripheral Line Parameters Page 1 (page 6-122)

Table 5-1 (Page 7 of 8). Keywords Used for Tuning

Keyword(subop- erand)	Minimum NCP Release	Tuning Field	NTuneMON Panel (Page Number)	
SPEED	LINE	V4R3.1 - ATUPL V6R2 - ATUFP V7R7 - ATUXP	Line Speed	ATUPL SDLC Physical Line Details (page 6-102) ATUFP Frame Relay Physical Line Details Page 1 (page 6-34) ATUXP X.25 MCH Physical Line Details Page 1 (page 6-189)
SRETRY	LINE	V5R3	SRETRY	ATUSP2 SDLC Peripheral Line Parameters Page 2 (page 6-134)
SSAP	PU	V7R5	SSAP	ATUTL Token-Ring SNA Station (page 6-156)
TEXTTO	GROUP	V7R2	TEXTTO	ATUSP2 SDLC Peripheral Line Parameters Page 2 (page 6-134) ATUMT Modify Timer Value (page 6-97)
TGCONF	PU	V7R6	CONGESTION STATION	ATUTL Token-Ring SNA Station (page 6-156) ATUSD SDLC Station Details (page 6-113) ATUFT1 Frame Relay Terminating Equipment Details Page 1 (page 6-64)
TGTIMER	BUILD NETWORK	V7R8	Alert Time Limit Deact Time Limit	ATUVT VR Alert Timer (page 6-185)
TITIMER	LINE	V7R1	TITIMER	ATUTP1 Token-Ring TIC Details Page 1 (page 6-170) ATUFP Frame Relay Physical Line Details Page 1 (page 6-34)
TRANSBUF	LINE	V7R6	TRANSBUF	ATUFP Frame Relay Physical Line Details Page 1 (page 6-34)
TRANSFR	LINE	V4R3.1	TRANSFR	ATUSP1 SDLC Peripheral Line Parameters Page 1 (page 6-122)
T2TIMER(<i>localt2</i> , <i>remott2</i> , <i>n3</i>)	LINE	V5R4	T2LOC T2REM N3GEN	ATUTL Token-Ring SNA Station (page 6-156)
T2TIMER(<i>localt2</i> , <i>n3</i>)	LINE	V6R2	T2 TIMER N3GEN	ATUFT1 Frame Relay Terminating Equipment Details Page 1 (page 6-64)
UNIQUE	PU	V7R6	UNIQUE	ATUTL Token-Ring SNA Station (page 6-156)
USE	LINE	V7R2	NCP USE	ATUSP1 SDLC Peripheral Line Parameters Page 1 (page 6-122)
USE	LINE	V7R2 (VTAM V4R2, see note)	VTAM USE	ATUSP1 SDLC Peripheral Line Parameters Page 1 (page 6-122)

Table 5-1 (Page 8 of 8). Keywords Used for Tuning

Keyword(subop- erand)	Minimum NCP Release	Tuning Field	NTuneMON Panel (Page Number)	
VRPWSnm	PATH	V4R3.1	VR Window Size Max VR Window Size Min	ATUVA Virtual Route Control Block Details (page 6-182)
VRTIMERn	BUILD NETWORK	V7R8	VR Alert Timer VR Deact Timer VR Transmit PIU Queue	ATUVT VR Alert Timer (page 6-185)
X21NTWK	GROUP	V4R3.1	X21NTWK	ATUSP1 SDLC Peripheral Line Parameters Page 1 (page 6-122)
X25SNAP	BUILD	V7R2	NPSI SNAP TRACE ENABLED	ATUST NCP Function Activation (page 4-269)
XMITDLY	GROUP	V7R2	XMITDLY	ATUSP2 SDLC Peripheral Line Parameters Page 2 (page 6-134) ATUMT Modify Timer Value (page 6-97)

Note: VTAM V4R2 with appropriate maintenance.

Refer to Chapter 6, “Using NTuneMON Panels for Tuning” on page 6-1 for detailed information on each tuning panel. For additional information on using NTuneMON panels, refer to “Using NTuneMON with PF Keys” on page 3-3.

How Color Is Used on NTuneMON Tuning Panels

Authorized users of NTuneNCP see tuning fields in any of the following three colors:

Reverse-Video Turquoise

Indicates a tuning field that can be modified.

Underscore White

Indicates a tuning field that cannot be modified until it is in the appropriate state. In most cases the resource will have to be inactive.

Reverse-Video Pink

Indicates a tuning field that was entered in error, or a tuning field that was not changed, or because of other tuning changes, is currently not valid.

Identifying and Analyzing Network Problems Using NTuneMON

Use the information provided on the NTuneMON panels to identify changes to your network necessary to address the changing needs of its users or to correct network problems.

NTuneMON panel fields are highlighted in specific reverse-video colors to alert you to potential network problems. By analyzing this information, along with other statistics provided on NTuneMON panels, you may be able to isolate problems in the network to a specific NCP resource whose parameter can be tuned to solve the problem.

Identify the tuning parameters associated with the resource you are tuning. General tuning suggestions are provided for each NCP tuning parameter. You can consider these suggestions to help you to decide the value that can best correct the problem. Refer to this chapter for detailed information about each NCP tuning parameter.

Once you have identified the tuning changes, you are ready to implement them.

Implementing Tuning Changes

Once you have identified a network problem and decided upon a course of action, you are ready to apply the tuning changes to your network. Use the appropriate NTuneMON panel to modify the NCP tuning parameters that provide the best solution for the network problem.

NCP tuning parameters are displayed in reverse-video turquoise. You can overwrite the current value of the tuning field with another value.

Submitting the Tuning Request

Depending upon what resources you are tuning, the options for submitting a tuning request are different. If you are making tuning changes to panels managing spare SDLC line resources, refer to “Submitting the Tuning Request for ATUSP1 and ATUSP2” on page 5-17. All other tuning requests are submitted as follows:

Tuning Your Network Using NTuneNCP

Press PF5=MODIFY to submit the tuning request. Once the value has been validated, NTuneMON automatically writes information about your tuning request to the active NetView network log (NETLOGA) and displays tuning parameter information to you on the NCCF screen of NetView. For example:

```
ATUM700 NTuneMON scheduled change of Genned MAXOUT from 3 to 4,  
      Panel ATUFT1, NCP A04NT02, Resource: A04LL34
```

This message advises you that a *request* to change the MAXOUT value from 3 to 4 was sent to the NCP's NTuneNCP function.

Note: To return to the NTuneMON panel when the NCCF screen is displayed, press the Enter key when you see three asterisks (***) displayed in the bottom left corner of the NCCF screen.

After the parameter is successfully changed, a message is displayed on the NCCF screen and written to the NetView NETLOGA. For example:

```
=> ATUM701 TB31FRT has had 1 change(s) made via Tuning
```

Verify Parameter Changes

You can use the active NetView network log (NETLOGA) to help you to verify parameter changes. To browse the active network log, enter the command BR NETLOGA on the NTuneMON or NetView command line. Check the *scheduled changes* against the values you expect to see on the panel for those fields.

When a tuning parameter cannot be modified due to an error condition, NTuneMON stops processing and displays a message to the operator. **It is important that you verify parameter field values if an error message is displayed after you have submitted a tuning request to modify multiple tuning fields.**

Say, for example, you submit one request to modify 3 parameters. The first parameter is successfully updated, but the second cannot be changed due to the link being active. NTuneMON does not process the third parameter. The message displayed to the user will be similar to the following message:

```
=> ATUM701 TB31FRT has had 1 change(s) made via Tuning
```

You can check the values in the appropriate field on the panel against the information in the NetView log to determine which fields were updated.

Return Codes

If NTuneNCP detects a problem during a tuning request, one of the following return codes is passed back to NTuneMon. These return codes, which might or might not be displayed, are provided here as an aid in problem determination.

0000 REQUEST SUCCESSFULLY PROCESSED

0001 REQUEST MISSING RETURN CODE SUBFIELD (X'80')

0002 REQUEST MISSING CAPABILITIES SUBFIELD (X'81')

0003 INVALID OR MISSING SUBFIELDS FOR REQUESTED SEQUENCE
SUPPORT

0004 REQUESTED SEQUENCING NOT SUPPORTED

0005 GROUP SUPPORT REQUIRED

0006 REQUESTED FUNCTION NOT SUPPORTED

0007 REQUESTED SUBFUNCTION NOT SUPPORTED
0008 INVALID VERIFY ADDRESS
0009 INVALID STORE ADDRESS
000A VERIFY CONDITIONS NOT TRUE
000B REQUEST TOO LARGE TO PROCESS
000C REPLY TOO LARGE TO BUILD
000D MISSING OR INVALID FUNCTION AND/OR SUBFUNCTION SUBFIELD
000E INVALID OR MISSING SUBFIELDS
000F REQUESTED FUNCTION HAS BEEN REJECTED

Verifying Tuning Changes for ATUSP1 and ATUSP2

For spare SDLC resources, you can use NTuneNCP to verify your tuning requests before you submit them by pressing F2=VERIFY from the ATUSP1 or ATUSP2 SDLC Peripheral Line Parameters Panels. This verifies all tuning parameters on ATUSP1 as shown on page 6-122, and ATUSP2 as shown on page 6-134.

Notes:

1. You must press F2=VERIFY before leaving a panel. Otherwise, values you have entered but not verified will be lost.
2. This process is different from the way other tuning fields in NTuneNCP are verified because many of the tuning parameters for spare SDLC resources are interrelated.

After NTuneMON has verified all tuning fields, any fields that are entered in error or are not valid because they are now inconsistent with fields that have been changed, are highlighted in reverse-video pink. If tuning fields are not valid, the following message is displayed:

```
ATUM738 Invalid tuning parameter. See log for details.
```

Use the active NetView network log (NETLOGA) to help you identify which tuning fields are in error and which tuning fields are interrelated. To browse the active network log, enter the command BR NETLOGA on the NTuneMON or NetView command line.

Verify tuning fields as many times as needed before submitting the tuning request.

Submitting the Tuning Request for ATUSP1 and ATUSP2

After verifying the tuning fields, submit the request by pressing either F4=MODIFY,ACT or F5=MODIFY. Press F4=MODIFY,ACT to reverify the fields, submit the tuning requests, and activate the line. Press F5=MODIFY to reverify the fields and submit the tuning requests; it does not activate or deactivate the line.

Making Changes Permanent

Modified values are used until the field is modified again or the NCP is reloaded or regenerated or, in some cases, only until the resource becomes inactive.

You can keep parameter changes by following these steps:

1. Determine the desired value.

Tuning Your Network Using NTuneNCP

Each modification to an NCP tuning parameter is automatically written to the NetView log. You can review this log to see the values of the parameters.

To browse the active NetView log, enter the command BR NETLOGA on the NTuneMON or NetView command line.

2. Update NCP's generation deck with the changes.
3. Regenerate the NCP.
4. Then, either reload the NCP or download the NCP load module and set up NCP to automatically load the new NCP load module the next time NCP reloads itself.

Chapter 6. Using NTuneMON Panels for Tuning

ATUBP NCP Buffer Pool Panel	6-4
ATUCH Channel Adapter Details Panel	6-10
ATUCL 3746-900 Station Details Panel	6-12
ATUDK ISDN Physical Line Details Panel	6-15
ATUDK2 ISDN Physical Line Details Page 2 Panel	6-19
ATUDT ISDN Station Details Panel	6-24
ATUFB Frame Relay DLCI CIR Parameters Panel	6-26
ATUFD Frame Relay DLCI to Balance Table Panel	6-29
ATUFI Frame-Relay IP Link Statistics Panel	6-32
ATUFP Frame Relay Physical Line Details Page 1 Panel	6-34
ATUFP2 Frame Relay Details Page 2 Panel	6-48
ATUFP3 Frame Relay Details Page 3 Panel	6-53
ATUFS1 Frame Relay Switching Equipment Page 1 Panel	6-61
ATUFT1 Frame Relay Terminating Equipment Details Page 1 Panel	6-64
ATUFT2 Frame Relay Terminating Equipment Details Page 2 Panel	6-78
ATUGP Network CB Pools/Tables Panel	6-81
ATUHP HPR & Other Global Flow Control Parm Panel	6-84
ATUID IP Interface Information Detail Panel	6-90
ATUML Multi-Link Transmission Group Panel	6-93
ATUMT Modify Timer Value Panel	6-97
ATUPL SDLC Physical Line Details Panel	6-102
ATUSD SDLC Station Details Panel	6-113
ATUSP1 SDLC Peripheral Line Parameters Page 1 Panel	6-122
ATUSP2 SDLC Peripheral Line Parameters Page 2 Panel	6-134
ATUST NCP Function Activation Panel	6-147
ATUTD NTRI Frame Handlers Logical Line Details Panel	6-152
ATUTL Token-Ring SNA Station Panel	6-156
ATUTP1 Token-Ring TIC Details Page 1 Panel	6-170
ATUTP2 Token-Ring TIC Details Page 2 Panel	6-178
ATUVA Virtual Route Control Block Details Panel	6-182
ATUVT VR Alert Timer Panel	6-185
ATUXP X.25 MCH Physical Line Details Page 1 Panel	6-189

This chapter provides a detailed description of the NTuneMON panels used for tuning. The following information is provided for each tuning field:

- Explanation of the tuning field including the NCP keyword that will be modified.
- Minimum NCP release required to modify the field.
- **NDF Default**
The network definition facility (NDF) default value of the tuning parameter. This value is provided for information only.
- **Valid NTune Values**
The acceptable values of the tuning parameter NTuneMON will accept.
Note: Valid values are provided when minimum and maximum do not apply.
- **Minimum**
Minimum value of the tuning parameter NTuneMON will accept.
- **Maximum**
Maximum value of the tuning parameter NTuneMON will accept.
- **Considerations**
Any restrictions or conditions that must be met before changing the tuning parameter.
- **Tuning Suggestions**
Suggestions and recommendations

Refer to the following publications for additional information on NCP parameters used for tuning.

- *NCP, SSP, and EP Resource Definition Guide*
- *NCP, SSP, and EP Resource Definition Reference*
- *NCP Version 7 and X.25 NPSI Version 3 Diagnosis, Customization, and Tuning*

Although this manual shows earlier release numbers on some panels, all actual NTuneMON V2R6 panels show the version and release as "V2R6".

ATUBP NCP Buffer Pool Panel

Basic fast-path commands: BP, BUF, BUFFERS, BUFPOOL

Tuning fields: IPPOOL TOTAL, DYNPOOL TOTAL, ALERT%, ALERT CNT, TSLOW%, TSLOW CNT, QSZALERT (THRESHLD1, THRESHLD2, ACTION)

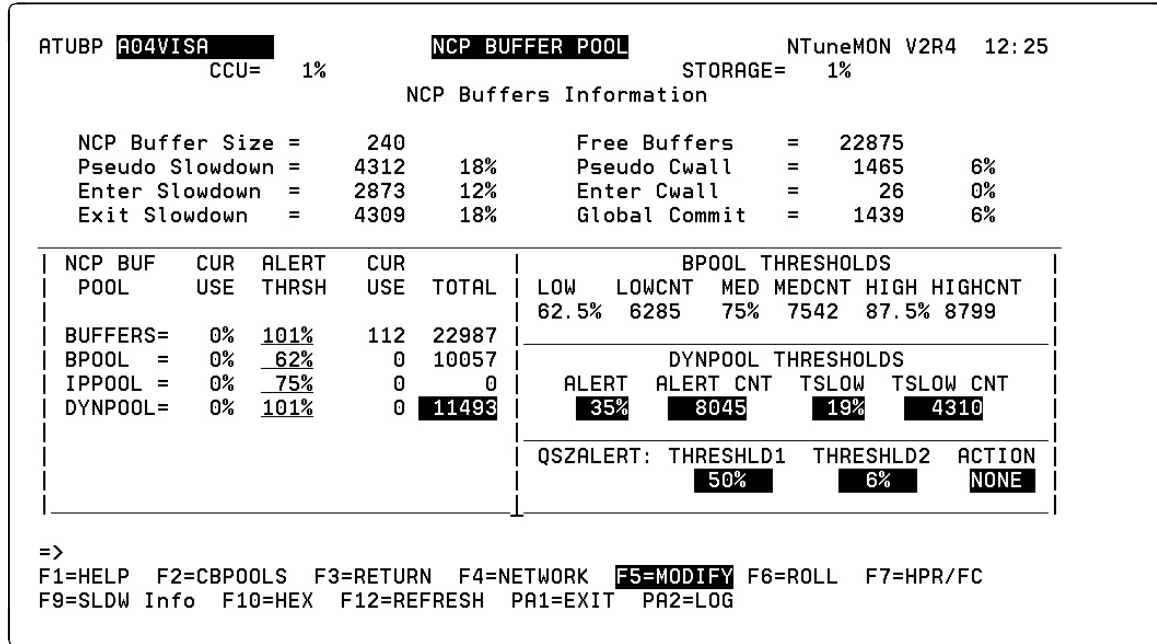

Figure 6-1. ATUBP NCP Buffer Pool Panel

Description

The ATUBP NCP Buffer Pool panel provides information on the use of NCP buffer pools and its subpools.

To display this panel:

- From the ATUCB Control Block Pools/Tables panel, as shown on page 4-17, press F2.
- From the ATUGP Network CB Pools/Tables panel, as shown on page 4-149, press F4.

Tuning Fields

IPPOOL TOTAL (NCP V6R1 or later releases)

Total number (rather than a percentage) of buffers that can be used to receive IP datagrams from a NTRI attached LAN (NCP V7R1), Ethernet-type LAN connections (NCP V6R1 or later releases), or frame-relay connections (NCP V7R3 or later releases). Defined by the IPPOOL keyword on the BUILD statement.

NDF Default

None

Note: If you specify a value that equals less than 6144 bytes of buffer storage, NCP uses 6144 as the limit.

Minimum

Enough buffers to ensure that 6144 bytes of data can be sent (6144/NCP Buffer Size).

Maximum

Number corresponding to 100% of the buffers over the slowdown threshold (Enter Slowdown) value.

Considerations

- If IPPOOL is not coded in the NCP generation, IPPOOL TOTAL cannot be modified.
- When the amount of internet data exceeds the limit, the excess IP datagrams are discarded.
- If you support IP and you do not code IPPOOL, NCP can use all the buffers for IP datagrams up to the slowdown threshold specified by the SLOWDOWN keyword on the BUILD statement, which can cause NCP to enter slowdown even when SNA traffic is light.
- You can enter a percentage or a number in this tuning field. If a percentage is entered, you must include a percent (%) sign after the number.

Tuning Suggestions

If IP datagrams are being discarded and SNA traffic is not congested, increase the value of IPPOOL TOTAL. If SNA traffic is congested, and datagrams are not being discarded, decrease the value of IPPOOL TOTAL.

DYNPOOL TOTAL (starting with NCP V7R1)

The total number (rather than a percentage) of buffers available for dynamic allocation of control blocks, as defined by the *percent_of_buffers* suboperand of the DYNPOOL keyword on the BUILD statement.

NDF Default

0

Minimum

0

Maximum

BUFFERS TOTAL minus Exit Slowdown.

Considerations

- When TOTAL=0, none of the buffer pool may be used for dynamic allocation of control blocks.
- When TOTAL > 0 , 128 bytes is the minimum valid size for BFRS on the BUILD definition statement.
- Modifying DYNPOOL TOTAL may cause the current value of ALERT CNT to be invalid.
- You can enter a percentage or a number in this tuning field. If a percentage is entered, you must include a percent (%) sign after the number.

Tuning Suggestions

- If DYNPOOL TOTAL is 0 and resource activation is failing due to a lack of control blocks, set DYNPOOL TOTAL to a non-zero value. This enables the dynamic control blocks function.

ATUBP NCP Buffer Pool Panel

- If DYNPOOL TOTAL is greater than 0 and resource allocation is failing due to the current value of DYNPOOL TOTAL being reached, increase the value of DYNPOOL TOTAL.

ALERT%, ALERT CNT (starting with NCP V7R1)

The threshold (percent and number of buffers in use for dynamic control blocks) at which NCP (not NTuneMON) is to send an alert (if specified) indicating that the user-defined threshold has been reached, as defined by the *alert_threshold* suboperand of the DYNPOOL keyword on BUILD statement.

Note: If the current percentage of buffers in use (CUR USE) for DYNPOOL exceeds the value of ALERT CNT, the field name (ALERT CNT) is highlighted in reverse-video red. The current value in this field is highlighted in reverse-video turquoise.

NDF Default

0

Minimum

0

Maximum

- $ALERT\% = (DYNPOOL\ TOTAL / BUFFERS\ TOTAL) \times 100$
- $ALERT\ CNT =$ Current value of *DYNPOOL TOTAL* field

Considerations

- If the alert threshold is set to the value of DYNPOOL TOTAL (DYNPOOL TOTAL = ALERT THRESHOLD), NCP will not send threshold alerts. Instead, NCP will send alerts indicating the buffer storage available for dynamically created resources is depleted.
- If *ALERT%* and *ALERT CNT* = 0, NCP will not send threshold alerts.

Tuning Suggestions

- If NCP is only sending DYNPOOL threshold alerts and not sending alerts indicating that the DYNPOOL limit has been reached, increasing the DYNPOOL ALERT CNT can decrease the number of DYNPOOL threshold alerts while still providing a warning to the user that DYNPOOL TOTAL is being approached.
- If NCP is not sending DYNPOOL threshold alerts soon enough to provide adequate warning that DYNPOOL TOTAL is being approached, decrease DYNPOOL ALERT CNT.

TSLOW%, TSLOW CNT (starting with NCP V7R1)

Threshold (percentage or number of free buffers) at which NCP is to fail a request for a dynamically created control block because NCP is too close to slowdown. TSLOW CNT is used to prevent the dynamic control block function from putting NCP into slowdown.

Note: Too Close to Slowdown Threshold (TSLOW) is set to Exit Slowdown plus one during NCP initialization.

NDF Default

N/A

Minimum

$TSLOW\% - (Enter\ Slowdown / BUFFERS\ TOTAL) \times 100$

$TSLOW\ CNT - Enter\ Slowdown\ value$

(Slowdown entry threshold value defined by the SLOWDOWN keyword on the BUILD statement.)

Maximum

$TSLOW\% - 100\%$

$TSLOW\ CNT - Initial\ Free\ Buffer\ Count\ (BUFFERS\ TOTAL),$ as defined during NCP initialization.

Considerations

When $TSLOW\%$ or $TSLOW\ CNT$ is modified, NTuneMON also modifies the TSLOW EXIT threshold value to 9/8 of the modified TSLOW value or BUFFERS TOTAL, whichever is smaller.

Tuning Suggestions

If control block allocation is failing due to this limit being reached, and NCP is not going into slowdown, consider decreasing TSLOW. Be careful not to lower TSLOW below EXIT SLOWDOWN, because this could cause NCP to experience difficulty recovering from slowdown.

QSZALERT: THRESHLD1 THRESHLD2 ACTION (starting with NCP V7R6)

This section of the panel displays the buffer-utilization alert parameters as specified on the QSZALERT keyword on the BUILD statement or as tuned on this panel. If the parameters are not set, zeroes are displayed in the THRESHLD fields.

- THRESHLD1 is the minimum percentage of NCP buffers above the slowdown entry threshold that should be available, as specified by the first suboperand of the QSZALERT keyword. If the amount of buffers available shrinks to this percentage, NCP begins checking for a session or station that is using an excessive amount of buffers.
- THRESHLD2 is the maximum percentage of NCP buffers above the slowdown entry threshold that should be in use by a single session or station, as specified by the second suboperand of the QSZALERT keyword. If a session or station is found to be using more than the specified amount of buffers, the operator is alerted and, if DEACT is coded on the QSZALERT keyword, the session or station is deactivated.
- ACTION indicates whether NCP will deactivate (DEACT) a resource that is overusing the buffers or allow it to remain active (NONE), as specified by the third suboperand of the QSZALERT keyword.

NDF Default

- THRESHLD1: None. If THRESHLD1 is not specified, then no queue size alert processing is performed.
- THRESHLD2: If THRESHLD1 is specified and THRESHLD2 is not specified, then THRESHLD2 defaults to 100 minus THRESHLD1.
- ACTION: If THRESHLD1 is specified and ACTION is not specified, then ACTION defaults to NONE.

ATUBP NCP Buffer Pool Panel

Valid Values

- THRESHLD1: Any whole number from 3 to the maximum. Note that this provides finer granularity than the *threshold_1%* suboperand of the QSZALERT keyword.
- THRESHLD2: Any whole number from 3 to the maximum. Note that this provides finer granularity than the *threshold_2%* suboperand of the QSZALERT keyword.
- ACTION: If NCP finds a resource that is overusing the buffers as specified by THRESHLD1 and THRESHLD2,
 - DEACT – NCP will deactivate the resource.
 - NONE – NCP will not deactivate the resource.

Minimum

THRESHLD1 – 3

THRESHLD2 – 3

Maximum

THRESHLD1 – 97

THRESHLD2 – 100 minus THRESHLD1.

Considerations

- You can initiate queue size alert processing, even if it was not coded in the gen, by entering a valid value for THRESHLD1.
- You can stop queue size alert processing, even if it was coded in the gen, by entering zero for THRESHLD1.
- A zero in the THRESHLD1 field indicates that queue size alerts are not currently supported.

Tuning Suggestions

None.

PF Keys

F1=HELP

Displays online help for this panel.

F2=CBPOOLS

Displays the ATUCB Control Block Pools/Tables panel as shown on page 4-17, to show control block pools usage.

F3=RETURN

Returns to the previous NTuneMON panel.

F4=NETWORK

Displays the ATUNG HSCBs and GWNAUs panel as shown on page 4-195.

F5=MODIFY (if NCP Buffer Size is 128 or greater)

Available when the operator has tuning authority, and NTuneNCP is included. For more information, refer to Chapter 5, Using the NTuneNCP Tuning Feature.

Updates the NCP tuning parameter with the modified value. If the modification is not valid, the field turns reverse-video pink, and you are prompted to correct the value and resubmit it.

F6=ROLL

Returns to the NetView command line without exiting NTuneMON. To return to NTuneMON from the NetView program, press F6=ROLL or enter **ATUNEMON** on the NetView command line.

F7=HPR/FC (if HPR resources are defined)

Displays the ATUHP HPR & Other Global Flow Control Params panel, as shown on page 6-84.

F9=SLDW Info

Displays the ATUBS Buffer Slowdown Information Page 1 panel, as shown on page 4-10, to show the slowdown FFDC data.

F10=HEX

Displays the ATUDP Hexadecimal Storage Display panel, as shown on page 4-68, to show the destination boundary pool (BPOOL) block for a network (BPB).

F12=REFRESH

Refreshes the information on this panel.

PA1=EXIT

Exits NTuneMON.

PA2=LOG

Saves the information on this panel to the NetView log.

ATUCH Channel Adapter Details Panel

Basic fast-path commands: None

Tuning fields: Network

```

ATUCH A13V7R8 Channel Adapter Details NTuneMON V2R6 13:37
Elapsed Time = 0
Adapter Position= 5 Type= CADS Name= A13CA5 Status= ACTIVE

  BUFFER PARAMETERS                THRESHOLDS
  UNITSZ          = 384             LOW = 800
  Max Receive Data= 32782          HIGH= 1600
  MAXBFRU GEN/CUR = 100/0

  PU INFORMATION                    CHANNEL TIMERS
  PU Name          = A13CP5          Attention Delay GEN/CUR (DELAY) = 0.0/0.0
  PU Status       = ACTIVE          Attention Timeout GEN/CUR (TIMEOUT)= 60/60
  PU Type         = T5              CA Slowdown Limit (CASDL) = 420
  Subarea.TG     = 11.1
  Network        = NETA             Negative Polls = 2688
  CPNAME         = N/A             Positive Polls = 0
                                       Total Polls = 2688

  POLLING
  Negative Polls = 2688
  Positive Polls = 0
  Total Polls = 2688

=>
F1=HELP          F3=RETURN          F6=ROLL
F10=HEX         F12=REFRESH,POLLING  PA1=EXIT        PA2=LOG
    
```

Figure 6-2. ATUCH Channel Adapter Details Panel

Description

The ATUCH Channel Adapter Details panel displays detailed information on CADS and BCCA channel adapters. For information on 3746 Model 900 adapters, see Figure 4-74 on page 4-237.

To display this panel: On the ATUSC1 Channel Adapters panel, as shown on page 4-230, tab the cursor under a channel adapter number and press Enter.

Tuning Fields

Network (starting with NCP V7R8)

The name of the network that contains the PU. Specified by the NETID keyword on the NETWORK definition statement.

NDF Default

None

Valid Values

The maximum length of a network name is 8 characters.

Considerations

- The channel must be inactive before you can modify this value.
- MONLINK=CONT must not be coded or allowed to default. Code MONLINK=YES.
- You must display the ATUNG panel before you can modify this value. If you added a dynamic network since the last display of ATUNG, then you

must redisplay ATUNG before modifying the Network field; otherwise a “not defined” message could be issued.

- Follow these steps to modify this field:
 1. Type the new network ID into the Network field.
 2. Press the F4 key.
 3. A message indicates whether the network ID was found. If it was not found, the Network field is highlighted in reverse pink, the field is set up to allow another modification, and you can return to step 1. If the network ID was found, the field is set up to prevent further changes until you perform the next step.
 4. Either press the F5 key to switch the display to the new network, or press the F12 key to refresh the panel.

Tuning Suggestions

None.

PF Keys

F1=HELP

Displays online help for this panel.

F2=IP DETAILS (if the channel has an IP address defined)

Displays the ATUID IP Interface Information Detail panel, as shown on page 4-164, to show details about a specific IP interface.

F3=RETURN

Returns to the previous NTuneMON panel.

F4=VERIFY

Attempts to verify the network ID that you typed in the Network field. NTuneMON will reply with a message that either indicates that the network ID was found or indicates that the network ID is not defined. For more information, see the description of the Network tuning field on page 6-10.

F5=MODIFY

Available after a network ID has been verified. Modifies the SCB control block with the **new** network ID.

F6=ROLL

Returns to the NetView command line without exiting NTuneMON. To return to NTuneMON from the NetView program, press F6=ROLL or enter **ATUNEMON** on the NetView command line.

F10=HEX

Displays the ATUDP Hexadecimal Storage Display panel, as shown on page 4-68, to show the channel adapter control block (CAB).

F11=CHAN IP STATS (if the channel has an IP address defined)

Displays the ATUCI Channel IP Statistics panel, as shown on page 4-36, to show IP statistics for a channel.

F12=REFRESH,POLLING

Refreshes the information on this panel to display polls per second instead of the number of polls since the last time the poll counter field wrapped.

PA1=EXIT

Exits NTuneMON.

ATUCL 3746-900 Station Details Panel

PA2=LOG

Saves the information on this panel to the NetView log.

ATUCL 3746-900 Station Details Panel

Basic fast-path commands: None

Tuning fields: Network

ATUCL A12V7R8		3746-900 Station Details		NTuneMON V2R6 13:54	
Physical Line= 2176 Type= ESCP Name= A12S2176 Status= ACTIVE					
Logical Line HOSTLINK= 1(01) Name= A12LS0C1 Status= ACTIVE					
PU INFORMATION		BUFFER PARAMETERS		THRESHOLDS	
PU Addr = 1(01)		UNITSZ = N/A		LOW = N/A	
PU Name = A12L1S1		Max Receive Data= 26382		HIGH= N/A	
PU Status = XID PEND		MAXBFRU GEN/CUR = 32/32			
PU Type = T5					
Subarea.TG= TGN=1		PACING			
Network =		Cur Min Max			
CPNAME = N/A		1 1 10			
CHANNEL TIMERS					
Attention Delay GEN/CUR (DELAY) = 0.2/0.2					
Attention Timeout GEN/CUR (TIMEOUT)= 150/150					
CA Slowdown Limit (CASDL) = NONE					
=>					
F1=HELP		F3=RETURN		F6=ROLL	
F10=HEX		F12=REFRESH PA1=EXIT		PA2=LOG	

Figure 6-3. ATUCL 3746-900 Station Details Panel

Description

The ATUCL 3746-900 Station Details panel displays detailed information on an ESCON logical station. This panel is available for NCP V6R2 or later releases. For this panel to be displayed, ESCON lines must be defined in the NCP generation and the 3746 Model 900 must be installed on the communication controller.

To display this panel: On the ATUCS 3746-900 Logical Lines panel, as shown on page 4-43, place the cursor under a station and press Enter.

Tuning Fields

Network (starting with NCP V7R8)

The name of the network that contains the PU. Specified by the NETID keyword on the NETWORK definition statement.

NDF Default

None

Valid Values

The maximum length of a network name is 8 characters.

Considerations

- The channel must be inactive before you can modify this value.
- MONLINK=CONT must not be coded or allowed to default. Code MONLINK=YES.
- You must display the ATUNG panel before you can modify this value. If you added a dynamic network since the last display of ATUNG, then you must redisplay ATUNG before modifying the Network field; otherwise a “not defined” message could be issued.
- Follow these steps to modify this field:
 1. Type the new network ID into the Network field.
 2. Press the F4 key.
 3. A message indicates whether the network ID was found. If it was not found, the Network field is highlighted in reverse pink, the field is set up to allow another modification, and you can return to step 1. If the network ID was found, the color of the Network field changes to yellow, and the field is set up to prevent further changes until you perform the next step.
 4. Either press the F5 key to switch the display to the new network, or press the F12 key to refresh the panel.

Tuning Suggestions

None.

PF Keys

F1=HELP

Displays online help for this panel.

F2=IP DETAILS (if the channel has an IP address defined)

Displays the ATUID IP Interface Information Detail panel, as shown on page 4-164, to show details about a specific IP interface.

F3=RETURN

Returns to the previous NTuneMON panel.

F4=VERIFY

Attempts to verify the network ID that you typed in the Network field. NTuneMON will reply with a message that either indicates that the network ID was found or indicates that the network ID is not defined. For more information, see the description of the Network tuning field on page 6-12.

F5=MODIFY

Available after a network ID has been verified. Modifies the SCB control block with the new network ID.

F6=ROLL

Returns to the NetView command line without exiting NTuneMON. To return to NTuneMON from the NetView program, press F6=ROLL or enter **ATUNEMON** on the NetView command line.

F10=HEX

Displays the ATUDP Hexadecimal Storage Display panel, as shown on page 4-68, to show the system status block (SSB).

ATUCL 3746-900 Station Details Panel

| **F11=CHAN IP STATS (if the channel has an IP address defined)**

| Displays the ATUCI Channel IP Statistics panel, as shown on page 4-36, to
| show IP statistics for a channel.

| **F12=REFRESH**

| Refreshes the information on this panel.

| **PA1=EXIT**

| Exits NTuneMON.

| **PA2=LOG**

| Saves the information on this panel to the NetView log.

ATUDK ISDN Physical Line Details Panel

Basic fast-path commands: None
 Tuning fields: CIR, PRE, MIR, PER

```

ATUDK  A04C901  ISDN Physical Line Details  NTuneMON V2R5  12:12

OWNERPL Function Active =  NO          Physical Station Details
-----
Physical Line Details
Line Name      = A04I2400
Line Address   = 2400,Full
Line Status    = INACTIVE
Speed         = 2048000
Clockng       = EXT
Max Frame     = 2048
Max DLCI      = 0
Data Block    = 2048
DYNWIND(nw)   = 4
DYNWIND(dw)   = 1
DYNWIND(dwc)  = 1
ISDN CRC      = CRC INCLUDED
ISDN IXF      = UDI
LPN           = 8037373732303030
LSA           = 8000

Station Name   = A04P2400
Station Address = 01
Station Status = INACTIVE
Line Timers
T1TIMER       = 60.0
DDTIMER       = 0
T391          = 10
T392          = 15
N391          = 6
N392          = 3
N393          = 4
Local Management Interface
LMI           = CCITT
CIR           = NO      MIR = -
PRE           = -      PER = -

=>
F1=Help      F2=B-Channel  F3=Return  F4=Stations  F5=MODIFY  F6=Roll  F8=DK PG 2
F10=Hex     F12=Refresh  PA1=Exit   PA2=Log
    
```

Figure 6-4. ATUDK ISDN Physical Line Details Panel

Description

The ATUDK ISDN Physical Line Details panel is available starting with NCP V7R5. It displays the physical line details for a selected ISDN line.

To display this panel:

- From the ATUDL ISDN Physical Line Table panel, as shown on page 4-59, place the cursor under a line address and press Enter.
- On the ATUDK2 ISDN Physical Line Details Page 2 panel, as shown on page 4-55, press F7.

Tuning Fields

CIR (starting with NCP V7R7)

Whether the committed information rate (CIR) algorithms are used for bandwidth and congestion management, as specified by the CIR keyword on the LINE statement.

NDF Default

NO

Considerations

- The physical line must be inactive before you can modify this value.
- If you specify CIR=NO, then the 3746 Model 900 uses its COMRATE procedures for bandwidth and congestion management.
- If you specify CIR=YES but do not specify any other CIR parameter, the 3746 Model 900 uses its automatically adjusting CIR algorithms.

ATUDK ISDN Physical Line Details Panel

- If you specify CIR=YES but code no DLCI statement, the 3746 Model 900 uses its automatically adjusting CIR algorithms.
- If multiple stations share a DLCI and the 3746 Model 900 receives multiple sets of CIR parameters for that DLCI, the 3746 Model 900 always uses the most recently received set of CIR parameters.
- B-channels are pooled resources, and you cannot be certain which B-channel will be used for a connection. Accordingly, the choice of bandwidth management algorithm (CIR or COMRATE) is made at the physical line (D-channel) level, and the same bandwidth management algorithm is used for all B-channels on a given physical line.

Tuning Suggestions

None

PRE (starting with NCP V7R7)

An integer used to determine the adaption speed of the CIR adaptive algorithm. Specified by the *precision* parameter of the CIR keyword on the LINE statement.

NDF Default

7

Minimum

6

Maximum

10

Considerations

- The physical line must be inactive before you can modify this value.
- You must specify CIR=YES before you can modify this value.

Tuning Suggestions

The larger the value, the slower the reaction. A large value would be most suitable to an environment with stable network conditions, and a small value would be most suitable to an environment with changing network conditions.

MIR (starting with NCP V7R7)

An integer used to determine the minimum information rate that the CIR adaptive algorithm can reach for a DLCI. Specified by the *mir%* parameter of the CIR keyword on the LINE statement.

NDF Default

25

Minimum

1

Maximum

100

Considerations

- The physical line must be inactive before you can modify this value.
- You must specify CIR=YES before you can modify this value.

Tuning Suggestions

None

PER (starting with NCP V7R7)

The interval, in seconds, used by the CIR adaptive algorithm to determine the CIR. Specified by the *period* parameter of the CIR keyword on the LINE statement.

NDF Default

Set by the 3746 Model 900 based on the PRE field or the *precision* parameter of the CIR keyword.

Minimum

.1

Maximum

10.0

Valid Values

A decimal number specifying tenths of a second, or DEFAULT

Considerations

- The physical line must be inactive before you can modify this value.
- You must specify CIR=YES before you can modify this value.
- If the 3746 Model 900 sets the default, then DEFAULT is displayed in this field.
- If you want to change from an explicit value back to the 3746-determined default, enter DEFAULT in this field.

Tuning Suggestions

None

See the *3745 Communication Controller Models A, 3746 Nways Multiprotocol Controller Models 900 and 950: Planning Guide, GA33-0457*, for more information about the Model 900 CIR processing.

PF Keys

F1=Help

Displays online help for this panel.

F2=B-Channel

Displays the ATUDM ISDN B-Channel Line Table panel, as shown on page 4-62, to list the B-channels for the currently displayed ISDN physical line.

F3=Return

Returns to the previous NTuneMON panel.

F4=Stations

Displays the ATUDS ISDN Stations Table List panel, as shown on page 4-71, to list the logical stations that can be attached to the B-channels for the currently displayed ISDN physical line.

F5=MODIFY (starting with NCP V7R7)

Available when the operator has tuning authority and NTuneNCP is included. For more information, refer to Chapter 5, Using the NTuneNCP Tuning Feature.

ATUDK ISDN Physical Line Details Panel

Updates the NCP tuning parameter with the modified value. If the modification is not valid, the field turns reverse-video pink, and you are prompted to correct the value and resubmit it.

F6=Roll

Returns to the NetView command line without exiting NTuneMON. To return to NTuneMON from the NetView program, press F6=Roll or enter **ATUNEMON** on the NetView command line.

F8=DK Pg 2 (starting with NCP V7R7)

Displays the ATUDK2 ISDN Physical Line Details Page 2 panel, as shown on page 4-55

F10=Hex

Displays the ATUDP Hexadecimal Storage Display panel, as shown on page 4-68, to show the line control block (LKB) for the currently displayed ISDN physical line.

F12=Refresh

Refreshes the information on this panel.

PA1=Exit

Exits NTuneMON.

PA2=Log

Saves the information on this panel to the NetView log.

ATUDK2 ISDN Physical Line Details Page 2 Panel

Basic fast-path commands: None

Tuning fields: HLOQSTOP, QSIZEDE, QSIZE, CRATEDLY, DSCRDDL, FRSPRI

```

ATUDK2  A71SUP1  ISDN Physical Line Details Pg2  NTuneMON V2R4  14:22
-----
Line Name   = A71I2368           Station Name   = A71P2368
Line Address = 2368,Full         Station Address = 01
Line Status  = INACTIVE         Station Status  = INACTIVE
DATA BLK    = 2048

-----
HLOQSTOP    = 12
QSIZEDE     = 120
QSIZE       = 130
CRATEDLY    = 12
DSCRDDL     = 13
FRSPRI      = 1

=>
F1=Help  F2=B-Channel  F3=Return  F4=Stations  F5=MODIFY  F6=Roll  F7=DK Pg 1
F9=DEFAULT F10=Hex    F12=Refresh  PA1=Exit    PA2=Log

```

Figure 6-5. ATUDK2 ISDN Physical Line Details Page 2 Panel

Description

The ATUDK2 ISDN Physical Line Details Page 2 panel, which is available starting with NCP V7R7, displays detailed information for a single 3746 Model 900 attached ISDN physical line.

To display this panel: From the ATUDK ISDN Physical Line Details panel, as shown on page 4-49, press F8.

Tuning Fields

Notes about the First Five Tuning Fields on this Panel (not applicable to FRSPRI):

1. If these fields display DEFAULT, then the values for these fields are provided by the 3746 Model 900.
2. If you modify DEFAULT with your own value in any of these fields, then you must specify values for all of these fields.

HLOQSTOP

The threshold that determines the maximum number of bytes that can be queued to the 3746 Model 900 attached ISDN line's hardware queue before a 3746 Model 900 software queue is created for the physical line. Defined by the HLOQSTOP keyword on the LINE statement. The value displayed in this field is multiplied by the DATA BLK value to determine the threshold in bytes.

NDF Default

Set by the 3746 Model 900 based on line speed

Minimum

1

Maximum

254

Considerations

- The physical line must be inactive before this field can be modified.
- See the *3745 Communication Controller Models A, 3746 Nways Multiprotocol Controller Models 900 and 950: Planning Guide*, GA33-0457, for more information about the Model 900 congestion control processing.

Tuning Suggestions

None

QSIZEDE

The 3746 Model 900 software queue threshold which, when it is reached, triggers the discarding of the last frames received with the Discard Eligible (DE) indicator set to binary 1. Defined by the QSIZEDE keyword on the LINE statement. The value displayed in this field is multiplied by the DATBLK value to determine the threshold in bytes.

NDF Default

Set by the 3746 Model 900 based on line speed

Minimum

0

Maximum

500

Valid Values

Must be less than or equal to QSIZE.

Considerations

- The physical line must be inactive before this field can be modified.
- See the *3745 Communication Controller Models A, 3746 Nways Multiprotocol Controller Models 900 and 950: Planning Guide*, GA33-0457, for more information about the Model 900 congestion control processing.

Tuning Suggestions

None

QSIZE

The 3746 Model 900 software queue threshold which, when it is reached, triggers the discarding of all the last frames received regardless of how the Discard Eligible (DE) indicator is set. Defined by the QSIZE keyword on the LINE statement. The value displayed in this field is multiplied by the DATBLK value to determine the threshold in bytes.

NDF Default

Set by the 3746 Model 900 based on line speed

Minimum

0

Maximum

500

Valid Values

Must be greater than or equal to QSIZEDE.

Considerations

- The physical line must be inactive before this field can be modified.
- See the *3745 Communication Controller Models A, 3746 Nways Multiprotocol Controller Models 900 and 950: Planning Guide*, GA33-0457, for more information about the Model 900 congestion control processing.

Tuning Suggestions

None

CRATEDLY

A threshold for a minimum time on the 3746 Model 900 software queue, used by the 3746 in conjunction with the DSCRDDLY and COMRATE values to trigger congestion controls (discarding of the frame or setting of the FECN indicator) under certain conditions.

If the frame has been on the software queue in excess of the amount of time specified by CRATEDLY but less than the amount of time specified by DSCRDDLY, then the following action will be taken:

- If more than 100% of the station's COMRATE has been used, then the frame will be discarded.
- If more than 75% but less than or equal to 100% of the station's COMRATE has been used, then the frame will be transmitted with the FECN indicator set to binary 1.
- If less than 75% of the station's COMRATE has been used, then the frame will be transmitted.

The value in this field is defined by the CRATEDLY keyword on the LINE statement.

NDF Default

Set by the 3746 Model 900 based on line speed

Minimum

.1

Maximum

25.4

Valid Values

Must be less than or equal to DSCRDDLY.

Considerations

- The physical line must be inactive before this field can be modified.
- See the *3745 Communication Controller Models A, 3746 Nways Multiprotocol Controller Models 900 and 950: Planning Guide*, GA33-0457, for more information about the Model 900 congestion control processing.

Tuning Suggestions

None

DSCRDDL

A threshold for a maximum time on the 3746 Model 900 software queue, used by the 3746 in conjunction with the CRATEDLY and COMRATE values to trigger congestion controls (discarding of the frame or setting of the FECN indicator) under certain conditions. Defined by the DSCRDDL keyword on the LINE statement.

NDF Default

Set by the 3746 Model 900 based on line speed

Minimum

.1

Maximum

25.4

Valid Values

Must be greater than or equal to CRATEDLY.

Considerations

- The physical line must be inactive before this field can be modified.
- See the *3745 Communication Controller Models A, 3746 Nways Multiprotocol Controller Models 900 and 950: Planning Guide, GA33-0457*, for more information about the Model 900 congestion control processing.

Tuning Suggestions

None

FRSPRI

A relative service priority at a station level, as defined by the FRSPRI keyword on the LINE statement.

NDF Default

0

Minimum

0

Maximum

3

Considerations

- The physical line must be inactive before this field can be modified.
- See the *3745 Communication Controller Models A, 3746 Nways Multiprotocol Controller Models 900 and 950: Planning Guide, GA33-0457*, for more information about the Model 900 congestion control processing.

Tuning Suggestions

None

PF Keys

F1=Help

Displays online help for this panel.

F2=B-Channel

Displays the ATUDM ISDN B-Channel Line Table panel, as shown on page 4-62, to list the B-channels for the currently displayed ISDN physical line.

F3=Return

Returns to the previous NTuneMON panel.

F4=Stations

Displays the ATUDS ISDN Stations Table List panel, as shown on page 4-71, to list the logical stations that can be attached to the B-channels for the currently displayed ISDN physical line.

F5=MODIFY

Available when the operator has tuning authority and NTuneNCP is included. For more information, refer to Chapter 5, Using the NTuneNCP Tuning Feature.

Updates the NCP tuning parameter with the modified value. If the modification is not valid, the field turns reverse-video pink, and you are prompted to correct the value and resubmit it.

F6=Roll

Returns to the NetView command line without exiting NTuneMON. To return to NTuneMON from the NetView program, press F6=ROLL or enter **ATUNEMON** on the NetView command line.

F7=DK Pg 1

Scrolls back to the ATUDK ISDN Physical Line Details panel, as shown on page 4-49.

F9=DEFAULT

Resets the HLOQSTOP, QSIZEDE, QSIZE, CRATEDLY, and DSCRDDLY fields to DEFAULT, which means that future values for these fields will be provided by the 3746 Model 900.

F10=Hex

Displays the ATUDP Hexadecimal Storage Display panel, as shown on page 4-68, to show the line control block (LKB) for the 3746 Model 900 line.

F12=Refresh

Refreshes the information on this panel.

PA1=Exit

Exits NTuneMON.

PA2=Log

Saves the information on this panel to the NetView log.

ATUDT ISDN Station Details Panel

Basic fast-path commands: None

Tuning fields: Station PRI, PIUCHECK Gen

```

ATUDT  A04C901  ISDN Station Details  NTuneMON V2R5  12:51
-----
|  B-Channel Information  |  Station Details  |
|-----|-----|
| Line Name      = N/A    | Station Name     = A04IBP01 |
| Line Status    = N/A    | Status           = INACTIVE |
| Line Address   = N/A    | Station Type     = BNN      |
|               | Station PRI      = 0        |
|               |                 Cur:      Gen: |
|-----|-----|
|  Destination Station  |
|-----|-----|
| IDBLK-IDNUM    = N/A    | MAXDATA         = 0         0 |
| CPNAME         = N/A    | MAXOUT          = 0         0 |
| DSAP           = 04     | DYNWIND(nw)    = 0         0 |
| TG             = N/A    | DYNWIND(dw)    = 0         0 |
| SUBAREA       = N/A    | DYNWIND(dwc)   = 0         0 |
| NETID         = N/A    | COMRATE        = FULL      |
|               | PIUCHECK       = N/A      N/A |
|               |                 Timers      |
| HPR non-ERP    = 00     | T1 Timer        = 0.0      |
| HPR send       = 00     | T2 Timer(1)    = 0.0      |
| HPR byte count = 0000  | N3GEN          = 00       |
|=>
F1=Help      F3=Return      F5=MODIFY      F6=Roll      F10=Hex
Enter=B-Channel Details  F12=Refresh    PA1=Exit      PA2=Log
    
```

Figure 6-6. ATUDT ISDN Station Details Panel

Description

The ATUDT ISDN Station Details panel is available starting with NCP V7R5. It displays detailed information on a selected ISDN logical station along with information on the assigned B-channel.

To display this panel: From the ATUDK ISDN Physical Line Details panel, as shown on page 4-49, press F8.

Tuning Fields

Station PRI (starting in NCP V7R7)

A relative service priority at a station level, as defined by the FRSPRI keyword on the PU statement.

NDF Default

0

Minimum

0

Maximum

3

Considerations

- The physical line must be inactive before this field can be modified.
- See the *3745 Communication Controller Models A, 3746 Nways Multiprotocol Controller Models 900 and 950: Planning Guide*, GA33-0457, for more information about the Model 900 congestion control processing.

Tuning Suggestions

None

PIUCHECK Gen (starting with NCP V7R7; subarea stations only)

Generated YES or NO value indicating whether a checksum validation is performed on PIUs sent from and received by this station. This field, unless tuned, is the value from the NCP generation (PIUCHECK keyword on the PU statement).

NDF Default

NO

Considerations

- The station must be inactive before you can modify this value.
- For the checksum validation to be enabled, the adjacent link station must also have PIUCHECK=YES.

Tuning Suggestions

The PIUCHECK support increases the path length required for NCP to send or receive a PIU, so the PIUCHECK support should be used only when the additional protection is required.

PF Keys**F1=Help**

Displays online help for this panel.

F3=Return

Returns to the previous NTuneMON panel.

F5=MODIFY (starting with NCP V7R7)

Available when the operator has tuning authority and NTuneNCP is included. For more information, refer to Chapter 5, Using the NTuneNCP Tuning Feature.

Updates the NCP tuning parameter with the modified value. If the modification is not valid, the field turns reverse-video pink, and you are prompted to correct the value and resubmit it.

F6=Roll

Returns to the NetView command line without exiting NTuneMON. To return to NTuneMON from the NetView program, press F6=Roll again or enter **ATUNEMON** on the NetView command line.

F10=Hex

Displays the ATUDP Hexadecimal Storage Display panel, as shown on page 4-68, to show the ISDN station control block (ISB) for the currently displayed ISDN line.

F12=Refresh

Refreshes the information on this panel.

Enter=B-Channel Details

Displays the ATUDN ISDN B-Channel Line Details panel, as shown on page 4-65, for the currently selected B-channel, if that channel is active.

PA1=Exit

Exits NTuneMON.

ATUFB Frame Relay DLCI CIR Parameters Panel

PA2=Log

Saves the information on this panel to the NetView log.

ATUFB Frame Relay DLCI CIR Parameters Panel

Basic fast-path commands: None

Tuning fields: Bc, Be, Tc

ATUFB A13SUTB Frame Relay DLCI CIR Parameters				NTuneMON V2R5 10:00			
Line Name = A13F2336		Datablk = N/A					
DLCI Address	Bc	Be	Tc	DLCI Address	Bc	Be	Tc
0(0)	1	1	1				
13(19)	6	6	5				
15(21)	8	8	5				
17(23)	4	4	10				
18(24)	2	1	1				
20(32)	2	2	10				

=>
F1=HELP F3=RETURN PA1=EXIT F6=ROLL F7=BACK F8=FORWARD
F10=HEX F12=RFRSH

Figure 6-7. ATUFB Frame Relay DLCI CIR Parameters Panel

Description

The ATUFB Frame Relay DLCI CIR Parameters panel, available starting with NCP V7R7, shows the DLCI parameter table for the associated 3746 Model 900-attached frame-relay physical line. The DLCI parameter table contains the DLCI addresses and associated CIR parameter values for the line.

To display this panel:

- From the ATUFP Frame Relay Physical Line Details Page 1 panel, as shown on page 4-108, press F4 when that panel is displaying a 3746 Model 900 line.
- From the ATUFP3 Frame Relay Details Page 3 panel, as shown on page 4-122, press F11 when that panel is displaying a 3746 Model 900 line for which CIR=YES.

Tuning Fields

If you coded CIR=YES in your gen and coded at least one DLCI statement for the line, the DLCI parameter table has at least one entry. The first entry in the table is always the "Default" entry.

Bc

Committed burst size, as specified by the *Bc* parameter of the CIR keyword on the DLCI statement. *Bc* is multiplied by *Datablk* to determine the maximum committed amount of data that a user can offer to the network during time interval *Tc*.

NDF Default

1

Minimum

0

Maximum

64

Valid Values

- Bc must be an integer.
- $(Bc+Be)>0$

Considerations

The physical line must be inactive before this field can be modified.

Tuning Suggestions

None

Be

Excess burst size, as specified by the *Be* parameter of the CIR keyword on the DLCI statement. *Be* is multiplied by *Datblk* to determine the maximum amount of data by which a user can exceed the committed burst size (*Bc*) during time interval *Tc*.

NDF Default

1

Minimum

0

Maximum

64

Valid Values

- *Be* must be an integer.
- $(Bc+Be)>0$

Considerations

The physical line must be inactive before this field can be modified.

Tuning Suggestions

None

Tc

Committed rate measurement interval, as specified by the *Tc* parameter of the CIR keyword on the DLCI statement.

NDF Default

.1

Minimum

.1

Maximum

25.5

Valid Values

Tc must be a decimal number specifying tenths of a second.

ATUFB Frame Relay DLCI CIR Parameters Panel

Considerations

The physical line must be inactive before this field can be modified.

Tuning Suggestions

None

PF Keys

F1=HELP

Displays online help for this panel.

F3=RETURN

Returns to the previous NTuneMON panel.

F5=MODIFY

Available when the operator has tuning authority and NTuneNCP is included. For more information, refer to Chapter 5, Using the NTuneNCP Tuning Feature.

Updates the NCP tuning parameter with the modified value. If the modification is not valid, the field turns reverse-video pink, and you are prompted to correct the value and resubmit it.

F6=ROLL

Returns to the NetView command line without exiting NTuneMON. To return to NTuneMON from the NetView program, press F6=ROLL or enter **ATUNEMON** on the NetView command line.

F7=BACK

Scrolls the panel data backward one screen.

F8=FORWARD

Scrolls the panel data forward one screen.

F10=HEX

Displays the ATUDP Hexadecimal Storage Display panel, as shown on page 4-68, to show the CIR table control block.

F12=REFRESH

Refreshes the information on this panel.

PA1=EXIT

Exits NTuneMON.

PA2=LOG

Saves the information on this panel to the NetView log.

ATUFD Frame Relay DLCI to Balance Table Panel

Basic fast-path commands: None

Tuning fields: Bal Factor

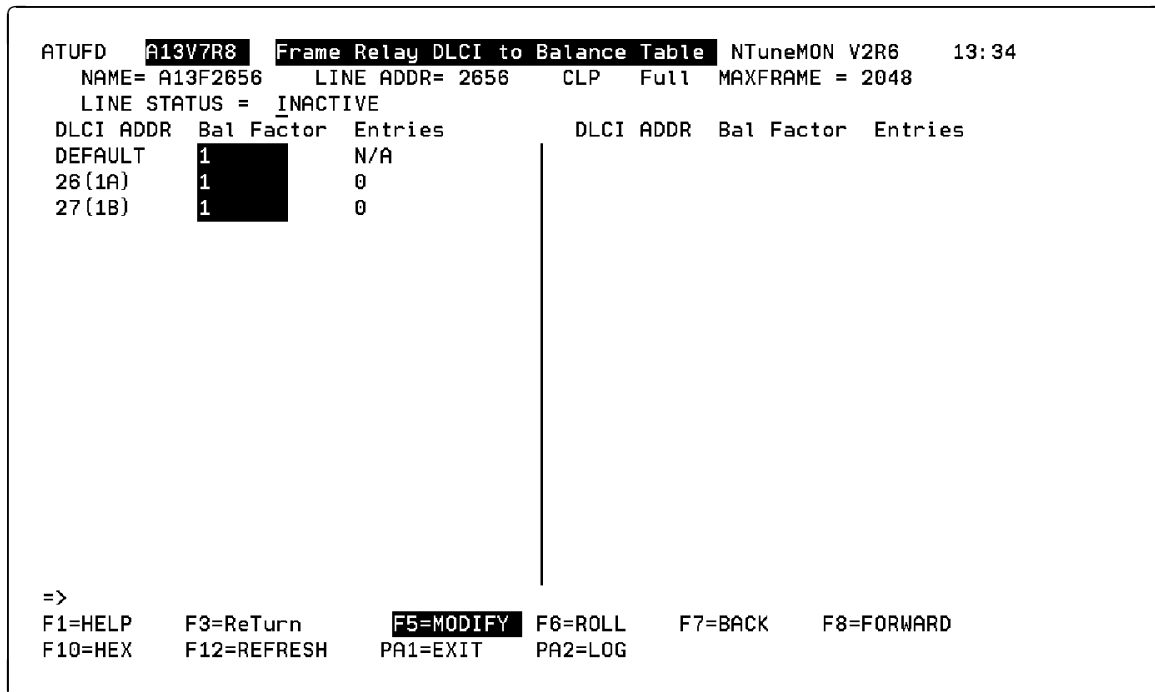

Figure 6-8. ATUFD Frame Relay DLCI to Balance Table Panel

Description

The ATUFD Frame Relay DLCI to Balance Table panel is available starting with NCP V7R7. It displays each DLCI for which a corresponding DLCI statement specifies the BALANCE keyword, and it displays the BALANCE keyword value for that DLCI.

To display this panel:

- On the ATUFP Frame Relay Physical Line Details Page 1 panel, as shown on page 4-108, press F7.
- On the ATUFP2 Frame Relay Details Page 2 panel, as shown on page 4-117, press F9.

Tuning Fields

Bal Factor

The balancing factor specified for the DLCI by the BALANCE keyword on the DLCI statement.

NDF Default

None

Valid Values

1-32 — The balancing factor for that DLCI.

0 — For only 3746 Model 900 lines and for only the “DEFAULT” row on the panel, turns off the genned balancing factor.

ATUFD Frame Relay DLCI to Balance Table Panel

AUTO — For only 3746 Model 900 lines, indicates that the auto-adaptive balancing function balances connections over the DLCI.

Considerations

None

Tuning Suggestions

- All associated DLCIs having the same BAN DLCI MAC address defined in the BAN router(s) must have nonzero balancing factors, in order for the balancing mechanism to function properly, if connection balancing is being performed for any one of the associated DLCIs.
- You can determine an approximate balancing factor by dividing the total number of downstream PUs to be supported by the DLCIs by 160 and rounding to the nearest integer from 1 through 32.
- balancing factor * 16 determines the connection granularity of the DLCI.
- Specify the same balancing factor for all associated DLCIs to achieve an approximate symmetrical distribution. Specifying differing balancing factors might result in a weighted distribution, depending on the network configuration.
- For more information about connection balancing, see the section on “DLCI Connection Balancing” on page 16-14 in the *Resource Definition Guide*.

PF Keys

F1=HELP

Displays online help for this panel.

F3=RETURN

Returns to the previous NTuneMON panel.

F5=MODIFY

Available when the operator has tuning authority, and NTuneNCP is included. For more information, refer to Chapter 5, Using the NTuneNCP Tuning Feature.

Updates the NCP tuning parameter with the modified value. If the modification is not valid, the field turns reverse-video pink, and you are prompted to correct the value and resubmit it.

F6=ROLL

Returns to the NetView command line without exiting NTuneMON. To return to NTuneMON from the NetView program, press F6=ROLL or enter **ATUNEMON** on the NetView command line.

F7=BACK

Scrolls the panel data backward one screen.

F8=FORWARD

Scrolls the panel data forward one screen.

F10=HEX

Displays the ATUDP Hexadecimal Storage Display panel, as shown on page 4-68, to show the DLCI-to-balance table (DTB) control block.

F12=REFRESH

Refreshes the information on this panel.

ATUFD Frame Relay DLCI to Balance Table Panel

PA1=EXIT

Exits NTuneMON.

PA2=LOG

Saves the information on this panel to the NetView log.

ATUFI Frame-Relay IP Link Statistics Panel

Basic fast-path commands: None
 Tuning fields: OUTBOUND QUEUE SIZE Maximum

```

ATUFI  A71C901  Frame-Relay IP Link Statistics  NTuneMON V2R5  09:09

                Station IP Statistics
DLCI      = 192(0C0)      Status: INACTIVE  Time Elapsed= 0
IP Address = 12.0.16.0    Line Address= 16
OUTBOUND QUEUE SIZE Current/Maximum =      0 / 16000

                IP Link Statistics



| FRAME-RELAY IP STATISTICS   | TRANSMITTED |     | RECEIVED |     |
|-----------------------------|-------------|-----|----------|-----|
| Total IP Bytes and Bit Rate | 0           | -   | 0        | -   |
| Total IP Frames             | 0           | -   | 0        | -   |
| Total IP Discarded Frames   | 0           | -   | 0        | 0   |
| Discarded (IP Congestion)   | N/A         | N/A | 0        | -   |
| IP Frames on Outbound Queue | 0           | N/A | N/A      | N/A |



=> ATUM017 Press F12 to see Traffic or Polling rates
F1=HELP F2=IP STATS F3=RETURN F4=IPLIST F5=MODIFY F6=ROLL F10=HEX PA1=EXIT
ENTER=IP INTERFACE INFORMATION DETAILS F12=REFRESH/TRAFFIC RATES PA2=LOG
    
```

Figure 6-9. ATUFI Frame-Relay IP Link Statistics Panel

Description

The ATUFI Frame-Relay IP Link Statistics panel is available for NCP V7R3 or later releases. It displays information about the first IPSP on the frame-relay line and IP traffic statistics for the frame-relay line.

To display this panel: On the ATUID IP Interface Information Detail panel, as shown on page 4-164, press F7.

Tuning Fields

OUTBOUND QUEUE SIZE Maximum

Maximum amount of data (in bytes) that can be queued for transmission, as defined by the IPQLIM keyword on the PU definition statement.

NDF Default

Three times the MAXFRAME value specified on the LINE definition statement

Minimum

The MAXFRAME value specified on the LINE definition statement

Maximum

65535

Considerations

None

Tuning Suggestions

None

PF Keys

F1=HELP

Displays online help for this panel.

F2=IP STATS

Displays the ATUIS IP Router Statistics Page 1 panel, as shown on page 4-175, to show global counters for IP datagrams and ICMP messages.

F3=RETURN

Returns to the previous NTuneMON panel.

F4=IPLIST

Displays the ATUIL IP Interface Information panel, as shown on page 4-169, to show information about an IP interface.

F5=MODIFY (starting with NCP V7R3)

Available when the operator has tuning authority and NTuneNCP is included. For more information, refer to Chapter 5, Using the NTuneNCP Tuning Feature.

Updates the NCP tuning parameter with the modified value. If the modification is not valid, the field turns reverse-video pink, and you are prompted to correct the value and resubmit it.

F6=ROLL

Returns to the NetView command line without exiting NTuneMON. To return to NTuneMON from the NetView program, press F6=ROLL or enter **ATUNEMON** on the NetView command line.

F10=HEX

Displays the ATUDP Hexadecimal Storage Display panel, as shown on page 4-68, to show the Ethernet statistical counters (ECT) control block.

PA1=EXIT

Exits NTuneMON.

ENTER=IP INTERFACE INFORMATION DETAILS

Displays the ATUID IP Interface Information Detail panel, as shown on page 4-164, to show detailed information about an IP interface.

F12=REFRESH/TRAFFIC RATES

Refreshes the information on this panel and displays traffic rates.

PA2=LOG

Saves the information on this panel to the NetView log.

ATUFP Frame Relay Physical Line Details Page 1 Panel

Basic fast-path commands: None

Tuning fields: Line Speed, NRZI, TITIMER, TRANSBUF, DYNWIND(nw), DYNWIND(dw), DYNWIND(dwc), DYNWIND(dwd), DYNWIND(twc), DYNWIND(mww), Receive Errors THRESH, LMI

```

ATUFP A12V7R8 Frame Relay Physical Line Details NTuneMON V2R6 16:31
Physical Line Details Page 1 Elapsed Time =30
Local Mgmt Interface DLCI 0
Line Addr = 20 LEASED
Line Name = A12F20 Status = INACTIVE
Line Type = TSS Full Duplex
Line Speed= 56000
NRZI = NO DYNWIND(nw) = 4
TITIMER = 60.0 DYNWIND(dw) = 1
CLOCKNG = EXT DYNWIND(dwc) = 1
MAXDLCI = 432 DYNWIND(dwd) = 1
TRANSBUF = 0 DYNWIND(twc) = YES
MAXFRAME = 2106 DYNWIND(mww) = 47
LMI = ANSI NO ECHO
LMI Activation Pending
LVL 3 Discards = 0
LVL 5 Discards = 0
PU Status = INACTIVE
          USER NETWORK
N391= 6 -
N392= 3/0 3/0
N393= 4 4
T391= 10 Sec -
T392= - 15 Sec
SEND= 0(00) 0(00)
RCVD= 0(00) 0(00)
          Source Addr = N/A
          NO ISDN BACKUP
Physical Line Frame Statistics
          Transmitted Received
Total Frames 0 - 0 -
Total Retries 0 -
I-Frame Retries 0 -
Frame Format Errors 0 -
Receive Errors CUR: 0 THRESH: 64
Last PSA Error Status
00000000 00000000 00000000 00000000
=> ATUM017 Press F12 to see Traffic or Polling rates
F1=HELP F2=DLCI/SUBA F3=RTN F4=DLCI CIR F5=MODIF F6=ROLL F7=BAL FA F8=FP PG2
ENTER=ONLY DLCIs F9=ISDN F10=HEX F12=RFRSH PA1=EXIT PA2=LOG
    
```

Figure 6-10. ATUFP Frame Relay Physical Line Details Page 1 Panel

Description

The ATUFP Frame Relay Physical Line Details Page 1 panel, which is available for NCP V6R1 or later releases, displays detailed information on a single frame-relay physical line.

To display this panel:

- On the ATUFC Physical Line List panel, as shown on page 4-94, place the cursor under a line and press Enter.
- On the ATUFS1 Frame Relay Switching Equipment Page 1 panel, as shown on page 4-127, place the cursor under the LINE ADDR field of a frame-relay physical line and press Enter.
- On the ATUFP2 Frame Relay Details Page 2 panel, as shown on page 4-117, press F7.
- On the ATUFP3 Frame Relay Details Page 3 panel, as shown on page 4-122, press F8.

Tuning Fields

Line Speed

Data rate for a line in bits per second as defined by the *rate* suboperand of the SPEED keyword on the LINE statement. This data rate is the rate at which the devices communicate with the communication controller.

NDF Default

None

Valid Values

The line speed that is actually used by NCP might differ from the line speed that you enter on this panel. To see the line speeds that NCP uses, and to decide which speed value you should specify, refer to the discussion of the SPEED keyword on the LINE statement in the *Resource Definition Reference* manual. The remainder of this "Valid Values" section discusses the **SPEED value that is displayed by NTuneMON**.

Beginning with NCP V7R7, NTuneMON displays the speed value exactly as you coded it in the gen or modified it on this panel.

For NCP V7R6 and earlier releases,

- See Table 6-1 on page 6-36 to find the displayed values for SPEED for frame-relay lines (TSS and HPTSS). These values are valid only for NCP V5R4 and later.
- See Table 6-2 on page 6-36 to find the displayed speed values for the 3746 Model 900 when CLOCKNG=DIRECT.
- See Table 6-3 on page 6-37 to find the displayed speed values for the 3746 Model 900 when CLOCKNG=EXT. When CLOCKNG=EXT, SPEED values for 3746 Model 900 frame-relay lines can be tuned to any value from 600 to 2048000. However, for NCP V7R6 and earlier, after you enter the value, it is converted and displayed as shown in Table 6-3.

Values that can be displayed but cannot be entered are:

NOT DEFIN

SPEED has not been coded or tuned to a valid value.

RPQ

SPEED is a non-standard value set by a special arrangement with IBM.

Table 6-1. Displayed SPEED Values for TSS and HPTSS Adapters when VERSION<V7R7

Data Rate (SPEED)	CLOCKNG=DIRECT	CLOCKNG=EXT ²
50	■	■
75	■	■
100	■	■
110	■	■
134	■	■
200	■	■
300	■	■
600	■	■
1200	■	■
2400	■	■
4800	■	■
9600	■	■
19200	■	■
38400	■	■
55855	■	■
245760	■	■
1843200 ¹	■	■

Notes:

¹ This speed is valid only for HPTSS lines.

² If you specified a value other than the ones shown in this column, the value you specified is displayed as follows: If the value is less than 1843200, the panel displays the next highest valid value in the table. For example, if 60 was specified, the panel displays 75. If a value greater than 1843200 was specified for SPEED, the panel displays 1843200.

Table 6-2. Displayed SPEED Values for 3746 Model 900 when CLOCKNG=DIRECT and VERSION<V7R7

Data Rate (SPEED)	CLOCKNG=DIRECT
600	■
1200	■
2400	■
4800	■
9600	■
19200	■
32000	
38400	■
55855	■
64000	■
256000	■
512000	■
1024000	■
1536000	■
2048000	■

Table 6-3. Displayed SPEED Values for 3746 Model 900 Frame-Relay Lines When CLOCKNG=EXT and VERSION<V7R7

Displayed SPEED Value	Actual Data Rate (SPEED) Values for CLOCKNG=EXT
19200	>= 600 and <= 32000
38400	> 32000 and <= 64000
256000	> 64000 and <= 256000
512000	> 256000

Considerations

The line must be inactive before this field can be modified.

Tuning Suggestions

When you use NPM, specify SPEED to ensure that line utilization is correctly calculated. Define SPEED as the clocking rate provided by the external source.

NRZI

Whether the DTE at the end of the frame-relay line must operate in non-return-to-zero change-on-ones NRZI mode (NRZI=YES) or in non-return-to-zero (NRZ) mode (NRZI=NO) as defined by the NRZI keyword on the LINE statement.

NDF Default

NO

Valid Values

- YES: Operate in non-return-to-zero change-on-ones mode.
- NO: Operate in non-return-to-zero mode.

Considerations

- The line must be inactive before this field can be modified.
- The value of NRZI must be the same at both ends of the line. Mixing modes on the same line results in a total lack of communication between stations on the line.

Tuning Suggestions

- NRZI is a configuration parameter, rather than a tuning parameter, and once set correctly, should not need to be modified.
- Set NRZI to match the attached modem:
 - Specify NRZI=YES for IBM modems.
 - Specify NRZI=NO for most non-IBM modems and all IBM 5812 and 5822 data set units.
 - If external (modem) clocking is used on the line, specify NRZI=YES unless the modem is sensitive to repeated binary one-zero patterns (for example, 10101010...). Sensitivity to this pattern can cause the modem to lose synchronism when it encounters sufficiently long sequences of this pattern in message data. If the modem is sensitive to this bit pattern, specify NRZI=NO.

TITIMER (starting with NCP V7R1)

Inactivity timer interval (TI), in seconds, that NCP is to wait for a transmitted frame from an adjacent station before sending a poll command, as defined by the **TITIMER** keyword on the **LINE** statement.

NDF Default

60.0

Minimum

10.0

Maximum

1500.0

Considerations

- For the 3745, can be modified at any time.
- For the 3746 Model 900, the line must be inactive before this field can be modified.
- As logical lines or stations that are associated with this particular physical line become active, they will begin using the new **TITIMER** value. This change does not affect logical lines or stations that are already active.

Tuning Suggestions

In most cases the default value is the best choice. If the TI timer value is too long, NCP can be delayed in detecting a failure in the adjacent station. If the TI timer value is too short, congestion can occur.

TRANSBUF (starting with NCP V7R7; not applicable to 3746 Model 900)

Maximum number of frames that will be queued for a TSS or HPTSS adapter, as defined by the **TRANSBUF** keyword on the **LINE** statement.

NDF Default

1 for TSS lines; 20 for HPTSS lines

Minimum

1

Maximum

4 for TSS lines, 20 for HPTSS lines

Considerations

- Can be modified only for 3745 TSS and HPTSS lines.
- The line must be inactive before this field can be modified.
- For HPTSS adapters with microcode not able to support subarea and peripheral connections on a single line, changing this field will have no effect. NCP will queue only one frame for the adapter. No error message will be given.

Tuning Suggestions

- Specify a small value to hold down the size of the queue so that frames have less latency time before being transmitted.
- A smaller queue allows various priority mechanisms (e.g., **COMRATE**) to operate more effectively.

- Specify a large value to allow a large queue, which yields better line utilization.

DYNWIND(nw) (starting with NCP V7R1)

Number of frames that must be received and acknowledged by the adjacent device before the sending NCP increases the IEEE 802.2 LLC working window value. When the sending NCP receives acknowledgements for *nw* consecutive I-frames, the working window value is increased until it reaches the value specified by MAXOUT for subarea connections, or the value specified in the VTAM switched major node for peripheral connections.

For NCP V7R1 and V7R2, the value in this field is defined by the *nw* suboperand of the DYNWIND keyword on the LINE statement for the physical frame-relay line. The value applies to all logical lines and stations associated with that physical line.

For NCP V7R3 or later releases, the value in this field is defined by the *nw* suboperand of the DYNWIND keyword on the LINE statement or (starting in NCP V7R5) PU statement for the physical frame-relay line. The value applies to all logical peripheral lines and stations associated with that physical line, except any peripheral station for which the DYNWIND(*nw*) value is defined in the VTAM switched major node.

For the 3745, the ATUFT1 Frame Relay Terminating Equipment Details Page 1 panel, as shown on page 6-64, can be used to modify the *nw* value for a particular logical station.

NDF Default

4

Minimum

1

Maximum

8

Considerations

- For the 3745, can be modified at any time.
- For the 3746 Model 900, the line must be inactive before this field can be modified.
- For NCP V7R1 and V7R2, as logical lines or stations that are associated with this particular physical line become active, they will begin using the new *nw* value. This change does not affect logical lines or stations that are already active.
- For NCP V7R3 or later releases, as logical peripheral lines or stations that are associated with this particular physical line become active, they will begin using the new *nw* value, unless they are peripheral stations whose DYNWIND(*nw*) values are defined in the VTAM switched major node. This change does not affect logical lines or stations that are already active.

Tuning Suggestions

In most cases, the default value is the best choice. However, in a frame-relay network where congestion is frequent or long-lasting (for example, longer than 30 seconds), increase DYNWIND(*nw*) to help alleviate congestion. This slows the transmission rate of affected stations for a longer time, to give the network more time to recover. In a frame-relay network where congestion is infre-

quent or lasts for a very short time, decrease DYNWIND(nw) to help the NCP recover more quickly.

DYNWIND(dw) (starting with NCP V7R1)

Value by which the sending NCP divides, or percentage by which the sending NCP reduces, the IEEE 802.2 LLC working window value when frame loss occurs.

For NCP V7R1 and V7R2, the value in this field is defined by the *dw* suboperand of the DYNWIND keyword on the LINE statement for the physical frame-relay line. The value applies to all logical lines and stations associated with that physical line.

For NCP V7R3 or later releases, the value in this field is defined by the *dw* suboperand of the DYNWIND keyword on the LINE statement or (starting in NCP V7R5) PU statement for a physical frame-relay line. The value applies to all logical peripheral lines and stations associated with that physical line, except any peripheral station for which the DYNWIND(dw) value is defined in the VTAM switched major node.

For the 3745, the ATUFT1 Frame Relay Terminating Equipment Details Page 1 panel, as shown on page 6-64, can be used to modify the *dw* value for a particular logical station.

NDF Default

1

Valid Values

1, 2, 4, 6[†], 8, 12[†], 16, 25[†], 50[†], 75[†], 87[†], 93[†]

Considerations

- 1 is a special value which indicates that the working window value should be set to its minimum value when frame loss is detected.
- For the 3745, can be modified at any time.
- For the 3746 Model 900, the line must be inactive before this field can be modified.
- For NCP V7R1 and V7R2, as logical lines or stations that are associated with this particular physical line become active, they will begin using the new *dw* value. This change does not affect logical lines or stations that are already active.
- For NCP V7R3 or later releases, as logical peripheral lines or stations that are associated with this particular physical line become active, they will begin using the new *dw* value, unless they are peripheral stations whose DYNWIND(dw) values are defined in the VTAM switched major node. This change does not affect logical lines or stations that are already active.

Tuning Suggestions

In most cases, the default value is the best choice. Also, if possible, you should first tune DYNWIND(dwc) to try to alleviate congestion. The loss of frames (*dw*) is a more severe condition than the congestion indicated by

[†] Allowed starting in NCP V7R6.

receiving BECNs (*dwc*). Mistuning DYNWIND(*dw*) may have a greater effect on throughput than mistuning DYNWIND(*dwc*).

However, in a frame-relay network where congestion is frequent or long-lasting (for example, longer than 30 seconds), you might want to increase DYNWIND(*dw*) to help alleviate congestion. This slows the transmission rate of affected stations for a longer time to give the network more time to recover. In a frame-relay network where congestion is infrequent or lasts for a very short time, you might want to decrease DYNWIND(*dw*) to help the NCP recover more quickly.

DYNWIND(*dwc*) (starting with NCP V7R1)

Value by which the sending NCP divides, or percentage by which the sending NCP reduces, the IEEE 802.2 LLC working window value when BECN occurs.

Defined by the *dwc* suboperand of the DYNWIND keyword on the LINE statement or (starting in NCP V7R5) PU statement for the physical frame-relay line.

For NCP V7R1 and V7R2, The *dwc* value for the physical line applies to all logical lines and stations associated with that physical line.

For NCP V7R3 or later releases, the *dwc* value of the physical line applies to all logical peripheral lines and stations associated with that physical line, except any peripheral station for which the DYNWIND(*dwc*) value is defined in the VTAM switched major node.

For the 3745, the ATUFT1 Frame Relay Terminating Equipment Details Page 1 panel, as shown on page 6-64, can be used to modify the *dwc* value for a particular logical station.

NDF Default

1

Valid Values

1, 2, 4, 6[†], 8, 12[†], 16, 25[†], 50[†], 75[†], 87[†], 93[†]

Considerations

- 1 is a special value which indicates that the working window value should be set to its minimum value when BECN is indicated.
- For the 3745, can be modified at any time.
- For the 3746 Model 900, the line must be inactive before this field can be modified.
- For NCP V7R1 and V7R2, as logical lines or stations that are associated with this particular physical line become active, they will begin using the new *dwc* value. This change does not affect logical lines or stations that are already active.
- For NCP V7R3 or later releases, as logical peripheral lines or stations that are associated with this particular physical line become active, they will begin using the new *dwc* value, unless they are peripheral stations whose DYNWIND(*dwc*) values are defined in the VTAM switched major node.

[†] Allowed starting in NCP V7R6.

This change does not affect logical lines or stations that are already active.

Tuning Suggestions

In most cases, the default value is the best choice. However, in a frame-relay network where congestion is frequent or long-lasting (for example, longer than 30 seconds), increase DYNWIND(*dwc*) to help alleviate congestion. This slows the transmission rate of affected stations for a longer time to give the network more time to recover. In a frame-relay network where congestion is infrequent or lasts for a very short time, decrease DYNWIND(*dwc*) to help the NCP recover more quickly.

DYNWIND(*dwd*) (starting with NCP V7R5; not applicable to 3746 Model 900 frame-relay physical lines)

Upper bound for the I-frame delay, in seconds. Defined by the *dwdmax* suboperand of the DYNWIND keyword on the LINE or PU statement.

NDF Default

1.0

Minimum

The minimum delay is 0.1 seconds. Zero indicates no delay.

Maximum

6.0

Considerations

- Applies only to 3745 frame-relay lines.
- Can be modified at any time.
- Effective only if the current value of DYNWIND(*mww*) is 1.
- Cannot be coded in the VTAM switched major node for peripheral stations and passed to NCP.

Tuning Suggestions

In most cases, the default value is the best choice. However, if you find that NCP is not reacting to congestion fast enough (and therefore is losing frames) or that NCP is consistently exceeding the allocated bandwidth capacity for the PVC¹, increase *dwd*.

DYNWIND(*twc*) (starting with NCP V7R5; not applicable to 3746 Model 900 frame-relay physical lines)

Whether NCP should ignore subsequent BECNs for 100 ms after an initial BECN is received. Defined by the *twcuse* suboperand of the DYNWIND keyword on the LINE statement or PU statement.

NDF Default

YES

Valid Values

- YES: NCP ignores subsequent BECNs.
- NO: NCP uses subsequent BECNs to adjust its working window.

¹ This might be true of a connection with a low committed information rate on a high-speed line.

Considerations

- Applies only to 3745 frame-relay lines.
- Can be modified at any time.
- Cannot be coded in the VTAM switched major node for peripheral stations and passed to NCP.

Tuning Suggestions

Leave *twc* at YES (the default) if you do not want your NCP to overreact to mild congestion.

DYNWIND(mww) (starting with NCP V7R8)

Lower bound for the IEEE 802.2 LLC working window when reduced for frame loss or BECN. Defined by the *mww* suboperand of the DYNWIND keyword on the LINE or PU statement.

NDF Default

1

Minimum

1

Maximum

127

Considerations

- Applies only to 3745 frame-relay lines.
- Cannot be coded in the VTAM switched major node for peripheral stations and passed to NCP.

Tuning Suggestions

In most cases, the default value is the best choice. Specify the minimum window value that you want the IEEE 802.2 LLC working window to be reduced to for frame loss and BECN.

Receive Errors THRESH (starting with NCP V7R5)

Maximum number of consecutive “errors” (that is, error-containing 100-millisecond periods) that the line is to tolerate. Defined by the first (*m*) suboperand of the RETRIES keyword on the physical GROUP or LINE statement. If this number is exceeded, NCP will INOP the line.

NDF Default

64 for TSS lines; 254 for HPTSS lines.

Minimum

The minimum threshold is 1 error. 'NONE' or 0 indicates that the line will not be brought down regardless of the number of received errors.

Maximum

The maximum threshold is 254. This allows the physical line to withstand an error burst that lasts up to 25.4 seconds.

Considerations

- Applies only to 3745 frame-relay physical lines.
- Because NCP counts only 1 error per 100-millisecond period, the value that you specify in this field is the number of consecutive 100-millisecond periods that have errors and not the actual number of consecutive errors.

Tuning Suggestions

Increase the threshold if you feel that NCP is INOPing frame relay links too quickly.

LMI (CCITT|CCITT-NUI|ANSI|ANSI-NUI|NO),(PRIMARY|SECONDARY|NO ECHO) (starting with NCP V6R2)

LMI protocol standard and NCP echo detection for this subport as defined by the LMI keyword on the PU statement. LMI protocol provides information on PVC status and line integrity.

(CCITT|CCITT-NUI|ANSI|ANSI-NUI|NO) (available starting with NCP V6R2; -NUI option available starting with NCP V7R6)

LMI protocol standard for this subport as defined by the first suboperand of the LMI keyword on the PU statement.

NDF Default

CCITT

Valid Values

- CCITT: Q.933 Annex A (the international LMI standard), with the interface (UNI, NNI, or NUI) determined by NCP.
- CCITT-NUI: Q.933 Annex A (the international LMI standard), with the Network-to-User interface.
- ANSI: ANSI T1.617 Annex D (the U.S. LMI standard), with the interface (UNI, NNI, or NUI) determined by NCP.
- ANSI: ANSI T1.617 Annex D (the U.S. LMI standard), with the Network-to-User interface.
- NO: The adjacent subport does not support LMI protocol.

Considerations

- Cannot be changed if NO is displayed instead of an LMI standard.
- Cannot be changed from an LMI standard to NO.
- Cannot be changed if the LMI PU is active.
- Cannot be changed from CCITT or ANSI to NO.
- Cannot be changed if the maximum DLCI address of the current standard is the wrong size for the standard to which you want to switch. To determine whether the standard can be changed, do the following computation:

$$((maxframe - fixed)/5) + 15$$

Where:

- *maxframe* is the value displayed for MAXFRAME on this panel.
- *fixed* is 17 if you want to switch to CCITT or 18 if you want to switch to ANSI.

If the value of your computation is equal to or greater than the value displayed for Max DLCI on this panel, you can switch the standard. However, if your computation is greater than the value of Max DLCI, the NCP might be supporting fewer DLCIs than if it had been generated with the standard to which you are switching.

Tuning Suggestions

- LMI protocol, which provides information on the PVC status and link integrity, should only be changed to prevent an LMI mismatch. Change CCITT to ANSI if you want to switch from the Q.933 Annex A international standard to the T1.617 Annex D U.S. standard. Change ANSI to CCITT if you want to switch from the T1.617 Annex D U.S. standard to the Q.933 Annex A international standard.
- The -NUI option is for shortening connect time when the adjacent device supports only a User-to-Network connection. It tells NCP to activate immediately, using the Network-to-User interface, without determining the interface type.

(PRIMARY|SECONDARY|NO ECHO) (starting with NCP V6R2)

Specifies that this subport is to support NCP echo detection and specifies which echo detection operating mode NCP is to use. Defined by the PRIMARY|SECONDARY suboperand of the LMI keyword on the PU statement.

Note: Echo detection is an NCP function; it is not a frame-relay standard.

NDF Default

None

Valid Values

- PRIMARY: NCP sets the Command/Response bit in outbound frames to 1.
- SECONDARY: NCP sets the Command/Response bit in outbound frames to 0.
- NO ECHO

Considerations

- Cannot be changed if NO is displayed instead of an LMI standard.
- The LMI PU must be inactive before this field can be changed.
- For no NCP echo detection, specify NO ECHO.
- To use NCP echo detection, specify PRIMARY or SECONDARY as follows:
 - If the subports on both ends of this line support NCP echo detection, specify primary for one subport and secondary for the other. It does not matter which subport you define as PRIMARY and which you define as SECONDARY.
 - If the Command/Response (C/R) bit is unused (that is, always set to 0) by the subport on the other end of this line, specify PRIMARY for this subport.

Tuning Suggestions

Specify NCP echo detection if this line will be involved in satellite communications with the NCP. NCP echo detection ensures that the NCP will not interpret an echo from a satellite as an incoming frame by setting the C/R bit in all outbound frames to 1 (PRIMARY) or 0 (SECONDARY) and rejecting any inbound frames whose C/R bit is the same as the C/R bit in the outbound frames.

PF Keys

F1=HELP

Displays online help for this panel.

F2=DLCI/SUBA

Displays the ATUFA Frame Relay Subport List panel, as shown on page 4-88, which shows all the DLCIs for this line. The subarea address is shown next to each SATESP DLCI.

F3=RTN

Returns to the previous NTuneMON panel.

F4=DLCI CIR (starting with NCP V7R7)

Available when DLCIs are genned and CIR=YES. Displays the ATUFB Frame Relay DLCI CIR Parameters panel, as shown on page 4-92, which shows any DLCI committed information rate (CIR) values for this line.

F5=MODIF

Available when the operator has tuning authority and if NTuneNCP is included. For more information, refer to Chapter 5, Using the NTuneNCP Tuning Feature.

Updates the NCP tuning parameter with the modified value. If the modification is not valid, the field turns reverse-video pink, and you are prompted to correct the value and resubmit it.

F6=ROLL

Returns to the NetView command line without exiting NTuneMON. To return to NTuneMON from the NetView program, press F6=ROLL or enter **ATUNEMON** on the NetView command line.

F7=BAL FA (starting with NCP V7R7)

Displays the ATUFD Frame Relay DLCI to Balance Table panel, as shown on page 4-99.

F8=FP PG 2 (starting with NCP V7R6)

Displays the ATUFP2 Frame Relay Details Page 2 panel, as shown on page 4-117.

F9=ISDN (starting with NCP V7R6)

Displays the ATUDL ISDN Physical Line Table panel, as shown on page 4-59, if the frame-relay line has ISDN backup assigned. If ISDN backup is not assigned, an error message is issued.

F10=HEX

Displays the ATUDP Hexadecimal Storage Display panel, as shown on page 4-68, to show the common physical unit block (CUB) for a 3745 line or the line control block (LKB) for a 3746 Model 900 line.

F11=FP PG 3 (starting with NCP V7R7; 3746 Model 900 only)

Displays the ATUFP3 Frame Relay Details Page 3 panel, as shown on page 4-122.

F12=RFRSH

Refreshes the information on this panel.

ENTER=ONLY DLCIs

Displays the ATUFA Frame Relay Subport List panel, as shown on page 4-88, which shows all the DLCIs for this line.

PA1=EXIT

Exits NTuneMON.

PA2=LOG

Saves the information on this panel to the NetView log.

ATUFP2 Frame Relay Details Page 2 Panel

Basic fast-path commands: None

Tuning fields: Priority, ANSTONE, RING, REDIAL

```

ATUFP2  A04SUP3  Frame Relay Details Page 2  NTuneMON V2R5  02:42
OWNERPL Function Active =  NO                      Elapsed Time =63

      Frame Information
Line Name= A04FL033  LEASED
Status =  INACTIVE                      DATABLK = 2048      MAXFRAME = 4096

      Priority      Max Size      Min Size      Number of      Estimated
                   Frame Sent    Frame Sent    Frames Sent    Bytes Sent
-----
LINE  N/A          -            -            -            -
SNA   1            -            -            -            -
IP    1            -            -            -            -
FH    1            -            -            -            -

      SNA Only
ANSTONE = N/A          AUTO = N/A          V25BIS= NO
RING    = N/A          DIAL  = NO
REDIAL  = ( N/A , N/A , N/A , N/A )

=>
F1=HLP F2=VERIFY F3=RTN F4=RESET MIN/ F5=MODIF F6=ROLL F7=FP PG 1
ENTER=ONLY DLCIs F10=HEX F12=RFRSH/RATES PA1=EXIT PA2=LOG
    
```

Figure 6-11. ATUFP2 Frame Relay Details Page 2 Panel

Description

The ATUFP2 Frame Relay Details Page 2 panel, which is available starting with NCP V7R6, displays detailed information for a single frame-relay physical line.

To display this panel:

- On the ATUFP Frame Relay Physical Line Details Page 1 panel, as shown on page 4-108, press F8.
- On the ATUFP3 Frame Relay Details Page 3 panel, as shown on page 4-122, press F7.

Tuning Fields

Priority

Relative communications rate priority for each protocol (SNA, IP, or frame handler) when supported by a 3745 frame-relay physical line. The transmit priority is defined by that protocol's *priority* suboperand of the FRRATES keyword on the LINE statement.

NTuneMON displays "N/A" for the line itself because it has no associated *priority* value under FRRATES.

NDF Default

1

Minimum

1

Maximum

64

Considerations

The value of the *priority* suboperand is multiplied by the value of the DATABLK keyword on the LINE statement to determine the guaranteed minimum number of bytes that a protocol can transmit before a different protocol must be given a transmission opportunity.

Tuning Suggestions

Unless you anticipate high volumes for a protocol, you should specify similar rates for all protocols.

ANSTONE

Whether NCP transmits an answer tone to the calling device to signify completion of the line connection. Defined by the ANSTONE keyword on the LINE statement. Used only for incoming calls on switched lines.

NDF Default

NO

Valid Values

- YES: NCP transmits an answer tone because the modem does not send one.
- NO: NCP does not transmit an answer tone because the modem provides one.

Considerations

- The line must be inactive before this field can be modified.
- If DIAL=NO, then ANSTONE does *not* apply.

Tuning Suggestions

If in doubt as to whether the modem supplies a tone, consult the supplier or installer of the modem.

RING

Whether the ring-indicator mode of an automatic answer operation is used. Defined by the RING keyword on the LINE statement. This decision depends upon the type of modem (data set) that connects the link to the controller.

NDF Default

NO

Valid Values

- YES: Ring indicator mode is used.
- NO: Ring indicator mode is not used.

Considerations

- The line must be inactive before this field can be modified.
- If DIAL=NO, then RING does not apply.
- If the modem has the ring-indicator interface, code RING=YES. If it does not, code RING=NO.

Tuning Suggestion

Code RING appropriately for the modem the line is attached to.

REDIAL(m, t1, n, t2)

Determines the timing and maximum number of dialing operations NCP performs in attempting to reach a device over a switched line, as defined by the REDIAL keyword on the LINE statement. NCP performs dialing operations in sequences, with a pause between dialing operations in each sequence and a pause between sequences.

Note: For switched frame-relay physical lines (that is, for lines with LNCTL=SDLC), the number of dialing operations in each sequence, REDIAL (*m*), is provided by the access method.

REDIAL(t1)

Specifies, in seconds, the pause between dialing operations in each sequence, as defined by the *t1* suboperand of the REDIAL keyword on the LINE statement.

NDF Default

0

Minimum

0

Maximum

765

Valid Values

Must be a multiple of 3.

REDIAL(n)

Determines the maximum number of dialing sequences, as defined by the *n* suboperand of the REDIAL keyword on the LINE statement.

NDF Default

0

Minimum

0

Maximum

255

Valid Values

Specify 255 for *n* to perform an unlimited number of sequences.

REDIAL(t2)

Specifies, in seconds, the pause between dialing sequences, as defined by the *t2* suboperand of the REDIAL keyword on the LINE statement.

NDF Default

0

Minimum

0

Maximum

765

Valid Values

Must be a multiple of 3.

Considerations

- The line must be inactive before this field can be modified.
- If $n=0$, $t2$ must=0.
- If DIAL=N0, REDIAL is not modifiable.
- If V25BIS=NO and AUTO=NONE, REDIAL is not modifiable.

Tuning Suggestions

None

PF Keys**F1=HLP**

Displays online help for this panel.

F2=VERIFY

Available when the operator has tuning authority and NTuneNCP is included.

Verifies that the tunable dial-related parameters near the bottom of the panel are within range and consistent with each other. Changes that are either not in range or not consistent are highlighted in reverse-video pink and are recorded in the NetView log. No changes are sent to NCP with this key. Use F5 to send changes.

F3=RTN

Returns to the previous NTuneMON panel.

F4=RESET MIN/MAX

Available when the operator has tuning authority and NTuneNCP is included. For more information, refer to Chapter 5, Using the NTuneNCP Tuning Feature.

Resets the values of the Max Size Frame Sent and Min Size Frame Sent fields. After resetting the fields, NTuneMON automatically refreshes the panel. If new traffic rates are available, they are displayed. Otherwise, NTuneMON displays a dash (–) until new traffic rates are available and you press F12 or reenter the panel to display the new rates. To reset these fields, place the cursor under the line or protocol you want and press F4.

F5=MODIFY

Available when the operator has tuning authority and NTuneNCP is included. For more information, refer to Chapter 5, Using the NTuneNCP Tuning Feature.

Updates the NCP tuning parameter with the modified value. If the modification is not valid, the field turns reverse-video pink, and you are prompted to correct the value and resubmit it.

F6=ROLL

Returns to the NetView command line without exiting NTuneMON. To return to NTuneMON from the NetView program, press F6=ROLL or enter **ATUNEMON** on the NetView command line.

ATUFP2 Frame Relay Details Page 2 Panel

F7=FP PG 2

Scrolls back to the ATUFP Frame Relay Physical Line Details Page 1 panel, as shown on page 4-108.

F8=FP PG 3 (starting with NCP V7R7; 3746 Model 900 only)

Scrolls forward to the ATUFP3 Frame Relay Details Page 3 panel as shown on page 4-122.

F9=BAL FACT (starting with NCP V7R7)

Displays the ATUFD Frame Relay DLCI to Balance Table panel, as shown on page 4-99.

ENTER=ONLY DLCIs

Displays the ATUFA Frame Relay Support List panel, as shown on page 4-88, which shows all the DLCIs for this line.

F10=HEX

Displays the ATUDP Hexadecimal Storage Display panel, as shown on page 4-68, to show the common physical unit block (CUB) for the 3745 line.

F12=REFRESH/TRAFFIC RATES

Refreshes the information on this panel and displays traffic rates.

PA1=EXIT

Exits NTuneMON.

PA2=LOG

Saves the information on this panel to the NetView log.

ATUFP3 Frame Relay Details Page 3 Panel

Basic fast-path commands: None

Tuning fields: FRSPRI, HLOQSTOP, QSIZEDE, QSIZE, CRATEDLY, DSCRDDLY, CIR, PRECISION, MIR Per, CLLM, Ty, PER

```

ATUFP3  A04C901  Frame Relay Details Page 3  NTuneMON V2R5  13:15

Line Addr = 2336      Line Type = CLP  Full Duplex
Line Name = A04FRL36  Status = INACTIVE
LEASED          DATABLK = N/A
*****
FRSPRI = 0
*****
HLOQSTOP = DEFAULT      CRATEDLY = DEFAULT
QSIZEDE  = DEFAULT      DSCRDDLY = DEFAULT
QSIZE    = DEFAULT
*****
CIR      = YES          CLLM    = NO
PRECISION = 7          Ty      = 11
MIR Per  = 25          PER     = DEFAULT

=>
F1=HLP  F3=RTN  F5=MODIFY F6=ROLL  F7=FP PG 2  F8=FP PG 1
ENTER=ONLY DLCIs  F11=DLCI CIR  F10=HEX  F12=REFRESH  PA1=EXIT  PA2=LOG
    
```

Figure 6-12. ATUFP3 Frame Relay Details Page 3 Panel

Description

The ATUFP3 Frame Relay Details Page 3 panel, which is available starting in NCP V7R7, displays detailed information for a single 3746 Model 900 attached frame-relay physical line.

To display this panel:

- From the ATUFP Frame Relay Physical Line Details Page 1 panel, as shown on page 4-108, press F11 when 3746 Model 900 information is being displayed.
- From the ATUFP2 Frame Relay Details Page 2 panel, as shown on page 4-117, press F8 when 3746 Model 900 information is being displayed.

Tuning Fields

FRSPRI

A relative service priority at a station level, as defined by the FRSPRI keyword on the LINE statement.

NDF Default

0

Minimum

0

Maximum

3

Considerations

- The physical line must be inactive before this field can be modified.
- See the *3745 Communication Controller Models A, 3746 Nways Multiprotocol Controller Models 900 and 950: Planning Guide, GA33-0457*, for more information about the Model 900 congestion control processing.

Tuning Suggestions

None

Notes about the Following Queue Congestion Control Fields (HLOQSTOP, QSIZEDE, QSIZE, CRATEDLY, and DSCRDDL):

1. If these fields display DEFAULT, then the values for these fields are provided by the 3746 Model 900.
2. If you modify DEFAULT with your own value in any of these fields, then you must specify values for all of these fields.

HLOQSTOP

The threshold that determines the maximum number of bytes that can be queued to the 3746 Model 900 attached frame-relay physical line's hardware queue before a 3746 Model 900 software queue is created for the physical line. Defined by the HLOQSTOP keyword on the LINE statement. The value displayed in this field is multiplied by the DATABLK value to determine the threshold in bytes.

NDF Default

Set by the 3746 Model 900 based on line speed

Minimum

1

Maximum

254

Considerations

- The physical line must be inactive before this field can be modified.
- See the *3745 Communication Controller Models A, 3746 Nways Multiprotocol Controller Models 900 and 950: Planning Guide, GA33-0457*, for more information about the Model 900 congestion control processing.

Tuning Suggestions

None

QSIZEDE

The 3746 Model 900 software queue threshold which, when it is reached, triggers the discarding of the last frames received with the Discard Eligible (DE) indicator set to binary 1. Defined by the QSIZEDE keyword on the LINE statement. The value displayed in this field is multiplied by the DATABLK value to determine the threshold in bytes.

NDF Default

Set by the 3746 Model 900 based on line speed

Minimum

0

Maximum

500

Valid Values

Must be less than or equal to QSIZE.

Considerations

- The physical line must be inactive before this field can be modified.
- See the *3745 Communication Controller Models A, 3746 Nways Multiprotocol Controller Models 900 and 950: Planning Guide*, GA33-0457, for more information about the Model 900 congestion control processing.

Tuning Suggestions

None

QSIZE

The 3746 Model 900 software queue threshold which, when it is reached, triggers the discarding of all the last frames received regardless of how the Discard Eligible (DE) indicator is set. Defined by the QSIZE keyword on the LINE statement. The value displayed in this field is multiplied by the DATABLK value to determine the threshold in bytes.

NDF Default

Set by the 3746 Model 900 based on line speed

Minimum

0

Maximum

500

Valid Values

Must be greater than or equal to QSIZEDE.

Considerations

- The physical line must be inactive before this field can be modified.
- See the *3745 Communication Controller Models A, 3746 Nways Multiprotocol Controller Models 900 and 950: Planning Guide*, GA33-0457, for more information about the Model 900 congestion control processing.

Tuning Suggestions

None

CRATEDLY

A threshold for a minimum time on the 3746 Model 900 software queue, used by the 3746 in conjunction with the DSCRDDLY and COMRATE values to trigger congestion controls (discarding of the frame or setting of the FECN indicator) under certain conditions.

If the frame has been on the software queue in excess of the amount of time specified by CRATEDLY but less than the amount of time specified by DSCRDDLY, then the following action will be taken:

- If more than 100% of the station's COMRATE has been used, then the frame will be discarded.

- If more than 75% but less than or equal to 100% of the station's COMRATE has been used, then the frame will be transmitted with the FECN indicator set to binary 1.
- If less than 75% of the station's COMRATE has been used, then the frame will be transmitted.

The value in this field is defined by the CRATEDLY keyword on the LINE statement.

NDF Default

Set by the 3746 Model 900 based on line speed

Minimum

.1

Maximum

25.4

Valid Values

Must be less than or equal to DSCRDDLY.

Considerations

- The physical line must be inactive before this field can be modified.
- See the *3745 Communication Controller Models A, 3746 Nways Multiprotocol Controller Models 900 and 950: Planning Guide, GA33-0457*, for more information about the Model 900 congestion control processing.

Tuning Suggestions

None

DSCRDDLY

A threshold for a maximum time on the 3746 Model 900 software queue, used by the 3746 in conjunction with the CRATEDLY and COMRATE values to trigger congestion controls (discarding of the frame or setting of the FECN indicator) under certain conditions. Defined by the DSCRDDLY keyword on the LINE statement.

NDF Default

Set by the 3746 Model 900 based on line speed

Minimum

.1

Maximum

25.4

Valid Values

Must be greater than or equal to CRATEDLY.

Considerations

- The physical line must be inactive before this field can be modified.
- See the *3745 Communication Controller Models A, 3746 Nways Multiprotocol Controller Models 900 and 950: Planning Guide, GA33-0457*, for more information about the Model 900 congestion control processing.

Tuning Suggestions

None

CIR (starting with NCP V7R7)

Whether the committed information rate (CIR) algorithms are used for bandwidth and congestion management, as specified by the CIR keyword on the LINE statement.

NDF Default

NO

Considerations

- The physical line must be inactive before you can modify this value.
- If you specify CIR=NO, then the 3746 Model 900 uses its COMRATE procedures for bandwidth and congestion management.
- If you specify CIR=YES but do not specify any other CIR parameter, the 3746 Model 900 uses its automatically adjusting CIR algorithms.
- If you specify CIR=YES but code no DLCI statement, the 3746 Model 900 uses its automatically adjusting CIR algorithms.
- If multiple stations share a DLCI and the 3746 Model 900 receives multiple sets of CIR parameters for that DLCI, the 3746 Model 900 always uses the most recently received set of CIR parameters.

Tuning Suggestions

None

PRECISION (starting with NCP V7R7)

An integer used to determine the adaption speed of the CIR adaptive algorithm. Specified by the *precision* parameter of the CIR keyword on the LINE statement.

NDF Default

7

Minimum

6

Maximum

10

Considerations

- The physical line must be inactive before you can modify this value.
- You must specify CIR=YES before you can modify this value.

Tuning Suggestions

The larger the value, the slower the reaction. A large value would be most suitable to an environment with stable network conditions, and a small value would be most suitable to an environment with changing network conditions.

MIR Per (starting with NCP V7R7)

An integer used to determine the minimum information rate that the CIR adaptive algorithm can reach for a DLCI. Specified by the *mir%* parameter of the CIR keyword on the LINE statement.

NDF Default

25

Minimum

1

Maximum

100

Considerations

- The physical line must be inactive before you can modify this value.
- You must specify CIR=YES before you can modify this value.

Tuning Suggestions

None

CLLM (starting with NCP V7R7)

Whether Consolidated Link Layer Management (CLLM) will be used. Specified by the CLLM keyword on the LINE statement.

NDF Default

NO

Considerations

CLLM=YES is valid only when CIR=YES.

Tuning Suggestions

None

Ty (starting with NCP V7R7)

The interval, in seconds, used by the Ty timer to determine when the congestion or outage condition has cleared. Specified by the Ty parameter of the CLLM keyword on the LINE statement.

NDF Default

11

Minimum

5

Maximum

30

Valid Values

Must be an integer.

Considerations

CLLM must equal YES before this field can be modified.

Tuning Suggestions

None

PER (starting with NCP V7R7)

The interval, in seconds, used by the CIR adaptive algorithm to determine the CIR. Specified by the *period* parameter of the CIR keyword on the LINE statement.

NDF Default

Set by the 3746 Model 900 based on the PRE field or the *precision* parameter of the CIR keyword.

Minimum

.1

Maximum

10.0

Valid Values

A decimal number specifying tenths of a second, or DEFAULT

Considerations

- The physical line must be inactive before you can modify this value.
- You must specify CIR=YES before you can modify this value.
- If the 3746 Model 900 sets the default, then DEFAULT is displayed in this field.
- If you want to change from an explicit value back to the 3746-determined default, enter DEFAULT in this field.

Tuning Suggestions

None

See the *3745 Communication Controller Models A, 3746 Nways Multiprotocol Controller Models 900 and 950: Planning Guide, GA33-0457*, for more information about the Model 900 CIR processing.

PF Keys**F1=HLP**

Displays online help for this panel.

F3=RTN

Returns to the previous NTuneMON panel.

F5=MODIFY

Available when the operator has tuning authority and NTuneNCP is included. For more information, refer to Chapter 5, Using the NTuneNCP Tuning Feature.

Updates the NCP tuning parameter with the modified value. If the modification is not valid, the field turns reverse-video pink, and you are prompted to correct the value and resubmit it.

F6=ROLL

Returns to the NetView command line without exiting NTuneMON. To return to NTuneMON from the NetView program, press F6=ROLL or enter **ATUNEMON** on the NetView command line.

F7=FP PG 2

Scrolls back to the ATUFP2 Frame Relay Details Page 2 panel, as shown on page 4-117.

F8=FP PG 1

Scrolls back to the ATUFP Frame Relay Physical Line Details Page 1 panel, as shown on page 4-108.

ENTER=ONLY DLCIs

Displays the ATUFA Frame Relay Support List panel, as shown on page 4-88, which shows all the DLCIs for this line.

F9=DEFAULT

Resets the HLOQSTOP, QSIZEDE, QSIZE, CRATEDLY, and DSCRDDLY fields to DEFAULT, which means that future values for these fields will be provided by the 3746 Model 900.

F10=HEX

Displays the ATUDP Hexadecimal Storage Display panel, as shown on page 4-68, to show the line control block (LKB) for the 3746 Model 900 line.

F11=DLCI CIR (starting with NCP V7R7)

Available when DLCIs are genned and CIR=YES. Displays the ATUFB Frame Relay DLCI CIR Parameters panel, as shown on page 4-92, which shows any DLCI committed information rate (CIR) values for this line.

F12=REFRESH

Refreshes the information on this panel.

PA1=EXIT

Exits NTuneMON.

PA2=LOG

Saves the information on this panel to the NetView log.

Considerations

- The value of the *priority* suboperand is multiplied by the value of the *DATABLK* keyword on the *LINE* statement to determine the guaranteed minimum number of bytes that a resource can transmit before a different resource must be given a transmission opportunity.
- Not modifiable for peripheral stations.
- For 3745 subarea stations, can be modified at any time. The change will be effective the next time a frame is sent.
- For 3746 Model 900 subarea stations, can be modified only when the station is inactive. The change will be effective when the station becomes active.

Tuning Suggestions

Unless you anticipate high volumes for an FHSP, you should specify similar *COMRATE* values for all FHSPs.

SERVICE PRI (starting with NCP V7R7; 3746 Model 900 only)

A relative service priority, at a station level, for the diagrammed 3746 Model 900 attached frame-relay switching equipment. Defined by the *FRSPRI* keyword on the *PU* statement.

NDF Default

0

Minimum

0

Maximum

3

Considerations

- The physical line must be inactive before this field can be modified.
- If this field displays N/A, then secondary subports are not defined for this resource. (The N/A cannot be modified.)
- See the *3745 Communication Controller Models A, 3746 Nways Multiprotocol Controller Models 900 and 950: Planning Guide*, GA33-0457, for more information about the Model 900 congestion control processing.

Tuning Suggestions

None

PF Keys

F1=HELP

Displays online help for this panel.

F3=RETURN

Returns to the previous NTuneMON panel.

F5=MODIFY

Available when the operator has tuning authority and NTuneNCP is included. For more information, refer to Chapter 5, Using the NTuneNCP Tuning Feature.

Updates the NCP tuning parameter with the modified value. If the modification is not valid, the field turns reverse-video pink, and you are prompted to correct the value and resubmit it.

F6=ROLL

Returns to the NetView command line without exiting NTuneMON. To return to NTuneMON from the NetView program, press F6=ROLL or enter **ATUNEMON** on the NetView command line.

F8=FORWARD

Scrolls forward to ATUFS2 Frame Relay Switching Equipment Page 2 as shown on page 4-131.

F10=HEX

Displays the ATUDP Hexadecimal Storage Display panel, as shown on page 4-68, to show the common physical unit block (CUB) for the FHSP. Place the cursor under the address of the line (LINE ADDR field) and press F10.

F12=REFRESH

Refreshes the information on this panel.

ENTER=LINE DETAILS

Displays one of the following panels:

- When the cursor is under the LINE ADDR field for a frame-relay physical line and you press Enter, the ATUFP Frame Relay Physical Line Details Page 1 panel, as shown on page 4-108 is displayed. This panel shows detailed information on the line.
- When the cursor is under the LINE ADDR field for a NTRI frame handler logical line and you press Enter, the ATUTD NTRI Frame Handlers Logical Line Details panel, as shown on page 4-285, is displayed. This panel shows detailed information on the line.

Place the cursor under the LINE ADDR field for the line you want to view and press Enter.

PA1=EXIT

Exits NTuneMON.

PA2=LOG

Saves the information on this panel to the NetView log.

ATUFT1 Frame Relay Terminating Equipment Details Page 1 Panel

Basic fast-path commands: None

Tuning fields: COMRATE, DYNWIND(nw), DYNWIND(dw), DYNWIND(dwc), DYNWIND(dwd), DYNWIND(twc), CONGESTION, STATION, T1 TIMER, T2 TIMER, N3GEN, #PIUs/block, MAXDATA GEN, MAXOUT GEN, BLOCK GEN, PIUCHECK GEN, MimWW GEN, SERVICE PRIORITY

```

ATUFT1 A04D1          Frame Relay Terminating          NTuneMON V2R6  12:44
Equipment Details Page 1          LLC Status: Link Opened
DLCI      = 17(11)                T1 Timer      = 20.0
Line Name = J00041FF              DYNWIND(nw)   = 4
Line Status= ACTIVE                DYNWIND(dw)   = 75
PU Name   = J0004200              DYNWIND(dwc)  = 25
COMRATE   = ( FULL , 1 )          DYNWIND(dwd)  = 5
CONGESTION = N/A                  STATION       = N/A
                                           MODE          = N/A
                                           DYNWIND(twc) = YES

```

NCP Physical Line		DESTINATION STATION Peripheral Node	
Line Addr = 34	TSS	IDBLK-IDNUM= 017-01285	DSAP = 14
PORTADD = 34	ACTIVE	CPNAME = -	TG = N/A
MAXFRAME = 4096		PU Status = ACTIVE	SUBAREA = N/A
			NETID= N/A

```

CUR:      GEN:
MAXDATA = 265      265
MAXOUT   = 3        3
BLOCK    = N/A     N/A
PIUCHECK= N/A     N/A
MimWW    = 3        8

```

```

FRAME RELAY BAN CONNECTION
Destination Address = N/A
SERVICE PRIORITY = N/A

```

=>
F1=HELP F3=RETURN F5=MODIFY F6=ROLL F8=FORWARD F10=HEX F12=REFRESH
ENTER=TG DETAILS PA1=EXIT PA2=LOG

Figure 6-14. ATUFT1 Frame Relay Terminating Equipment Details Page 1 Panel

Description

The ATUFT1 Frame Relay Terminating Equipment Details Page 1 panel, which is available for NCP V6R2 or later releases, provides information on the logical line associated with a particular DLCI.

To display this panel:

- On the ATUFA Frame Relay Support List panel, as shown on page 4-88, place the cursor under a TESP DLCI and press Enter.
- From the ATUFT2 Frame Relay Terminating Equipment Details Page 2 panel, as shown on page 4-143, press F7.

Tuning Fields

Notes:

1. The values in the GEN fields are either from the NCP generation or from NCP processing that overwrote the values from the NCP generation.
2. The values in the CUR fields are working values that are either set or limited by the corresponding GEN fields.
3. All peripheral TESP's are switched, whereas all subarea TESP's are leased.

COMRATE (FULL|NONE,priority)

Specifies whether certain frames sent by this TESP can be discarded by the frame-relay network to expedite the processing of other frames when the network is congested. It also specifies the relative transmit priority for a TESP. Defined by the COMRATE keyword on the LINE and PU statements.

COMRATE (FULL|NONE)

Whether certain frames sent by this TESP can be discarded by the frame-relay network to expedite the processing of other frames when the network is congested. Defined by the FULL|NONE suboperand of the COMRATE keyword on the LINE statement.

NDF Default

FULL

Valid Values

- FULL: Specifies that no frames sent by this TESP are discard-eligible.
- NONE: Specifies that all frames sent by this TESP are to be discard-eligible except for the following types:
 - S-frames (RR, RNR, and REJ), including RRs piggybacked on I-frames
 - Network priority frames (virtual route pacing and TG sweep)
 - XIDs

Considerations

- Not modifiable for peripheral stations.
- For 3745 subarea stations, can be modified at any time. The change will be effective the next time a frame is sent.
- For 3746 Model 900 subarea stations, can be modified only when the station is inactive. The change will be effective when the station becomes active.

Tuning Suggestions

- Frames in a frame-relay network can be designated as *discard-eligible*. When the network is congested, discard-eligible frames may be discarded to facilitate the processing of frames that are not discard-eligible. Designating frames as not discard-eligible helps ensure that they are transmitted successfully through the network.
- COMRATE=FULL should always be used in a frame-relay network that attaches non-SNA devices because these devices will indicate all of their traffic as not discard eligible. COMRATE=NONE should be used in an SNA-only frame-relay network to facilitate throughput.

COMRATE (priority) (NCP V7R2 or later releases)

Relative transmit priority for this TESP as defined by the priority suboperand of the COMRATE keyword on the PU statement.

NDF Default

1

Minimum

1

Maximum

64

Considerations

- The value of the *priority* suboperand is multiplied by the value of the *DATABLK* keyword on the *LINE* statement to determine the guaranteed minimum number of bytes that a TESP can transmit before a different TESP must be given a transmission opportunity.
- Not modifiable for peripheral stations.
- For 3745 subarea stations, can be modified at any time. The change will be effective the next time a frame is sent.
- For 3746 Model 900 subarea stations, can be modified only when the station is inactive. The change will be effective when the station becomes active.

Tuning Suggestions

Unless you anticipate high volumes for a TESP, you should specify similar *COMRATE* values for all TESPs.

CONGESTION (starting with **NCP V7R6**)

The station's role in congestion relief as defined by the third parameter of the *TGCONF* keyword on the *PU* definition statement:

- If the station can be used to relieve congestion, this field displays the station's threshold percentage.
- If the station can be used as a standby station but not to relieve congestion, this field displays *NONE*.
- If the station cannot be used as a standby station, this field displays *N/A*.

NDF Default

NONE

Valid Values

- 3, 6, 12, 25, 50, 75, 87, 93, 97, or 100: Defines the congestion threshold as a percentage of the *totthresh* parameter coded on the *ERn* keyword on the associated *PATH* statement. When this congestion threshold is exceeded, the standby station will help transmit data until the congestion is relieved.
- *NONE*: The station will not be used to relieve congestion. *NONE* is required when the *STATION* field displays *NORMAL* or when *SINGLE* was coded as the first parameter of the *TGCONF* keyword on the *PU* statement.

Considerations

- This field applies only to a transmission group subarea link station that has been designated as hot-standby station (*TGCONF=STANDBY*).
- The station must be inactive before this field can be modified.
- The standby station can transmit data when this congestion threshold is exceeded.

Tuning Suggestions

None.

DYNWIND(nw) (starting with NCP V7R1)

Number of frames that must be received and acknowledged by the adjacent device before the sending NCP increases the IEEE 802.2 LLC working window value. When the sending NCP receives acknowledgements for *nw* consecutive I-frames, the working window value is increased until it reaches the value specified by MAXOUT for subarea connections, or the value specified in the VTAM switched major node for peripheral connections.

For NCP V7R1 and V7R2, the value in this field is defined by the *nw* suboperand of the DYNWIND keyword on the LINE statement for a physical frame-relay line. The value applies to all logical lines and stations associated with that physical line.

For NCP V7R3 or later releases, the value in this field is defined by the *nw* suboperand of the DYNWIND keyword on the PU statement for a logical subarea frame-relay station. For a peripheral station, the value is defined in the VTAM switched major node, or if not defined in VTAM, on the physical LINE statement.

NDF Default

4

Minimum

1

Maximum

8

Considerations

- For the 3745, the *nw* associated with this logical line is modifiable if the following conditions are true:
 - The logical line is open.
 - The logical station is active.
 - For logical peripheral stations, the logical line is associated with the same physical line as when this panel was displayed. For example, if the logical line has gone down and the line's control blocks have been reused for a different line, the modification is not allowed.

Notes:

1. For NCP V7R1 and V7R2, the change applies only to this logical line and remains in effect only for as long as the logical line is active. To make permanent changes for all logical lines on the physical line, use the ATUFP Frame Relay Physical Line Details Page 1 panel, as shown on page 6-34.
 2. For NCP V7R3 or later releases, if this is a logical subarea station, the change is permanent. If this is a logical peripheral station, the change remains in effect only for as long as the station is active. To make permanent changes, change the definition in the VTAM switched major node.
- Not modifiable for 3746 Model 900.

Tuning Suggestions

In most cases, the default value is the best choice. However, in a frame-relay network where congestion is frequent or long-lasting (for example, greater than 30 seconds), increase DYNWIND(nw) to help alleviate congestion. This slows the transmission rate of affected stations for a longer time to give the network more time to recover. In a frame-relay network where congestion is infrequent or lasts for a very short time, decrease DYNWIND(nw) to help the NCP recover more quickly.

DYNWIND(dw) (starting with NCP V7R1)

Value by which the sending NCP divides, or percentage by which the sending NCP reduces, the IEEE 802.2 LLC working window value when frame loss occurs.

For NCP V7R1 and V7R2, the value in this field is defined by the *dw* suboperand of the DYNWIND keyword on the LINE statement for a physical frame-relay line. The value applies to all logical lines and stations associated with that physical line.

For NCP V7R3 or later releases, the value in this field is defined by the *dw* suboperand of the DYNWIND keyword on the PU statement for a logical subarea frame-relay station. For a peripheral station, the value is defined in the VTAM switched major node, or if not defined in VTAM, on the physical LINE statement.

NDF Default

1

Valid Values

1, 2, 4, 6[†], 8, 12[†], 16, 25[†], 50[†], 75[†], 87[†], 93[†]

Considerations

- 1 is a special value which indicates that the working window value should be set to its minimum value when frame loss is detected.
- For 3745 lines, the *dw* associated with this logical line is modifiable if the following conditions are true:
 - The logical line is open.
 - The logical station is active.
 - For logical peripheral stations, the logical line is associated with the same physical line as when this panel was displayed. For example, if the logical line has gone down and the line's control blocks have been reused for a different line, the modification is not allowed.

Notes:

1. For NCP V7R1 and NCP V7R2, the change applies only to this logical line and remains in effect only for as long as the logical line is active. To make permanent changes for all logical lines on the physical line, use the ATUFP Frame Relay Physical Line Details Page 1 panel, as shown on page 6-34.

[†] Allowed starting in NCP V7R6.

2. For NCP V7R3 or later releases, if this is a logical subarea station, the change is permanent. If this is a logical peripheral station, the change remains in effect only for as long as the station is active. To make permanent changes, change the definition in the VTAM switched major node.

- Not modifiable for 3746 Model 900 lines.

Tuning Suggestions

In most cases, the default value is the best choice. Also, if possible, you should first tune DYNWIND(*dwc*) to try to alleviate congestion. The loss of frames (*dw*) is a more severe condition than the congestion indicated by receiving BECNs (*dwc*). Mistuning DYNWIND(*dw*) might have a greater effect on throughput than mistuning DYNWIND(*dwc*).

However, in a frame-relay network where congestion is frequent or long-lasting (for example, longer than 30 seconds), you might want to increase DYNWIND(*dw*) to help alleviate congestion. This slows the transmission rate of affected stations for a longer time to give the network more time to recover. In a frame-relay network where congestion is infrequent or lasts for a very short time, you might want to decrease DYNWIND(*dw*) to help the NCP recover more quickly.

DYNWIND(*dwc*) (starting with NCP V7R1)

Value by which the sending NCP divides, or percentage by which the sending NCP reduces, the IEEE 802.2 LLC working window value when BECN occurs.

For NCP V7R1 and NCP V7R2, the value in this field is defined by the *dwc* suboperand of the DYNWIND keyword on the LINE statement for a physical frame-relay line. The value applies to all logical lines and stations associated with that physical line.

For NCP V7R3 or later releases, the value in this field is defined by the *dwc* suboperand of the DYNWIND keyword on the PU statement for a logical subarea frame-relay station. For a peripheral station, the value is defined in the VTAM switched major node, or if not defined in VTAM, on the physical LINE statement.

NDF Default

1

Valid Values

1, 2, 4, 6[†], 8, 12[†], 16, 25[†], 50[†], 75[†], 87[†], 93[†]

Considerations

- 1 is a special value which indicates that the working window value should be set to its minimum value when BECN is indicated.
- For 3745 lines, *dwc* associated with this logical line is modifiable if the following conditions are true:
 - The logical line is open.
 - The logical station is active.

[†] Allowed starting in NCP V7R6.

- For logical peripheral stations, the logical line is associated with the same physical line as when this panel was displayed. For example, if the logical line has gone down and the line's control blocks have been reused for a different line, the modification is not allowed.

Notes:

1. For NCP V7R1 and NCP V7R2, the change applies only to this logical line and remains in effect only as long as the logical line is active. To make permanent changes for all logical lines on the physical line, use the ATUFP Frame Relay Physical Line Details Page 1 panel, as shown on page 6-34.
2. For NCP V7R3 or later releases, if this is a logical subarea station, the change is permanent. If this is a logical peripheral station, the change remains in effect only as long as the station is active. To make permanent changes, change the definition in the VTAM switched major node.
 - Not modifiable for 3746 Model 900 lines.

Tuning Suggestions

In most cases, the default value is the best choice. However, in a frame-relay network where congestion is frequent or long-lasting (for example, longer than 30 seconds), increase DYNWIND(dwc) to help alleviate congestion. This slows the transmission rate of affected stations for a longer time to give the network more time to recover. In a frame-relay network where congestion is infrequent or lasts for a very short time, decrease DYNWIND(dwc) to help the NCP recover more quickly.

DYNWIND(dwd) (starting with NCP V7R5; not applicable to 3746 Model 900 frame-relay logical lines)

Upper bound for the I-frame delay, in seconds. Defined by the *dwdmax* sub-operand of the DYNWIND keyword on the LINE or PU statement.

NDF Default

1.0

Minimum

The minimum delay is 0.1 seconds. Zero indicates no delay.

Maximum

6.0

Considerations

- Applies only to 3745 frame-relay lines.
- Can be modified at any time.
- Effective only if the value of the MimWW CUR field is 1.
- Cannot be coded in the VTAM switched major node for peripheral stations and passed to NCP.

Tuning Suggestions

In most cases, the default value is the best choice. However, if you find that NCP is not reacting to congestion fast enough (and therefore is losing frames)

or that NCP is consistently exceeding the allocated bandwidth capacity for the PVC², increase *dwd*.

STATION (starting with NCP V7R6)

Whether the station can be used for hot standby (STANDBY) or cannot (NORMAL), as defined by the TGCONF keyword on the PU definition statement.

NDF Default

NORMAL

Valid Values

- NORMAL: The station can transmit data anytime data is queued for transmission.
- STANDBY: The station is reserved for use as a hot-standby station. STANDBY is not valid if no TGCONF keyword or TGCONF=SINGLE was coded on the PU definition statement.

Considerations

- This field applies only to a transmission group subarea link station.
- The station must be inactive before this field can be modified.

Tuning Suggestions

None.

T1 TIMER

Reply timer (T1) value for stations connected to a frame-relay network. Defined by the LOCALTO keyword on the LINE statement or the *localt1* suboperand of the T1TIMER keyword on the LINE statement.

NDF Default

6.0

Minimum

0.6

Maximum

20.0

Considerations

- Can be modified only for subarea stations.
- The station must be inactive before this field can be modified.
- An INOP 02 can occur on a frame-relay physical line if it is used to perform a remote load. To avoid this condition, the LMI error threshold time interval for the link station subport should be at least three times the T1 timer interval for the logical subarea line. The LMI error threshold time interval is $T391 \times N392$, where $T391$ is a time interval defined by the ERRORT keyword on the PU statement for the link station subport, and $N392$ is an error count threshold defined by the TIMERS keyword on the same PU statement.

² This might be true of a connection with a low committed information rate on a high-speed line.

Tuning Suggestions

- Values used for the reply timer by NCP and the adjacent link station should be similar. Using values that differ by a factor of 5 or more can result in performance problems and unnecessary station INOP requests.
- Specify a larger value than 6.0 (the default) for slower (less than T1 speed) frame-relay lines.
- If a backup route for a PVC is defined in the frame-relay network, code a value for the LOCALTO keyword or the *localt1* suboperand of the T1TIMER keyword on the LINE statement that is greater than the LMI error threshold of any node in the PVC. This gives the network time to switch to the backup PVC.

T2 TIMER

Timer value used for connections over a local (T2LOC) frame-relay network as defined by the *localt2* suboperand of the T2TIMER keyword on the LINE statement.

NDF Default

- 1.0 if the line number of the corresponding physical line is in the range 0–895 or, for 3746 Model 900 logical subarea lines, if the speed of the corresponding physical line is less than 256 KB.
- 0.2 if the line number of the corresponding physical line is in the range 1024–1039 or, for 3746 Model 900 logical subarea lines, if the speed of the corresponding physical line is greater than or equal to 256 KB.

Minimum

0.0 — This value indicates that the timer is not to be used for this line.

Maximum

2.0

Considerations

- Can be modified only for subarea stations.
- The station must be inactive before this field can be modified.
- Decreasing the T2TIMER value limits the number of retransmissions because of a line error.
- Increasing the T2TIMER value potentially increases the number of retransmissions due to line error.

Tuning Suggestions

The local remote acknowledgement timer value should be approximately one-tenth the value specified for the reply timer for the adjacent station. This ensures that the adjacent station receives the acknowledgement before its reply timer expires.

N3GEN

Maximum number of I-frames that NCP can receive without sending an acknowledgement, as defined by the *n3* suboperand of the T2TIMER keyword on the LINE statement.

NDF Default

2 or the GROUP statement.

Minimum

1

Maximum

127

Considerations

- Can be modified only for subarea stations.
- The station must be inactive before this field can be modified.

Tuning Suggestions

The acknowledgement window size should be less than the value of MAXOUT specified by the other NCP or other device.

#PIUs/block

Maximum number of PIUs for multiple-PIU frames, as defined by the *pius* suboperand of the BLOCK keyword on the PU statement.

NDF Default

0 if the value of *bytes* (BLOCK) is 0; otherwise, the default is 8.

Minimum

0 if the value of *bytes* (BLOCK) is 0; otherwise, the minimum is 2.

Maximum

16

Considerations

- Can be modified only for subarea stations.
- If BLOCK is not 0, then #PIUs/block must be greater than 0.

Tuning Suggestions

To reduce the number of interframe gaps, set both BLOCK and #PIUs/BLOCK as high as possible.

DYNWIND(*twc*) (starting with NCP V7R5; not applicable to 3746 Model 900 frame-relay logical lines)

Whether NCP should ignore subsequent BECNs for 100 ms after an initial BECN is received. Defined by the *twcuse* suboperand of the DYNWIND keyword on the LINE or PU statement.

NDF Default

YES

Valid Values

- YES: NCP ignores subsequent BECNs.
- NO: NCP uses subsequent BECNs to adjust its working window.

Considerations

- Applies only to 3745 frame-relay lines.
- Can be modified at any time.
- Cannot be coded in the VTAM switched major node for peripheral stations and passed to NCP.

Tuning Suggestions

Leave *twc* at YES (the default) if you do not want your NCP to overreact to mild congestion.

MAXDATA GEN

Maximum number of bytes this PU can send or receive in one data transfer.

NDF Default

For a subarea station: If not specified, MAXDATA is not used to determine the segment size on a multilink transmission group (MLTG).

Minimum

Subarea Station: 26 + (Value of BFRS on the BUILD statement)

Maximum

65535

The value of MAXDATA on the logical PU statement must not exceed the value of MAXFRAME on the LINE statement for the physical line.

Considerations

- Can be modified only for subarea stations and only if MAXDATA is some value other than 0 or dash (-).
- Only the generated value can be modified.
- The station must be inactive before this field can be modified.
- If you do not specify MAXDATA, NCP does not take MAXDATA into consideration when calculating segment size for a MLTG. Refer to the discussion of MLTGs in *NCP, SSP, and EP Resource Definition Guide* for more information on using MAXDATA to coordinate segment size for different line control protocols in a MLTG.
- Not modifiable for peripheral TESP's because all are switched.

Tuning Suggestions

- Should be set to a value that is equal to the smallest segment size used by any link in the MLTG, thereby eliminating transmission problems due to incompatible segment sizes for different links in the MLTG.
- Should be set as large as possible for a device to minimize segmentation.
- Should be a multiple of the BFRS keyword on the BUILD statement to optimize the transmitted frame size to a minimum number of segmented frames because NCP will segment PIUs into multiples of NCP buffers. In addition, consider the 26 bytes required for the TH.

MAXOUT GEN

Generated MAXOUT value, used to negotiate MAXOUT CUR.

Peripheral FRTE stations are defined as switched resources. Therefore, the MAXOUT GEN value for these stations comes from the PU definition statement in the VTAM switched major node (SMN) definitions.

Subarea FRTE stations are defined as nonswitched resources. Therefore, the MAXOUT GEN value for these stations comes from the NCP PU definition statement that defines the subarea station.

NDF Default

8

Frame-relay TESP logical stations operate as if attached to a modulo-128 line.

Minimum

1

Frame-relay TESP logical stations operate as if attached to a modulo-128 line.

Maximum

127

Frame-relay TESP logical stations operate as if attached to a modulo-128 line.

Considerations

- Can be modified only for subarea stations.
- The station must be inactive before this field can be modified.
- Only the generated value can be modified.
- Specify a MAXOUT value that can be supported by the physical device.
- Not modifiable for peripheral TESP's because all are switched.

Tuning Suggestions

- If retransmissions exist and MAXOUT is high, lower MAXOUT.
- A high MAXOUT can reduce the number of acknowledgements and time spent waiting for acknowledgements but might increase the number of PIUs that must be retransmitted in a retry sequence.

BLOCK GEN

Maximum size in bytes for frames transmitted over this subarea as defined by the *bytes* suboperand of the BLOCK keyword on the PU statement.

NDF Default

0

Minimum

0

Maximum

8192 if MAXDATA is 0; otherwise, this value must be less than or equal to the value of MAXDATA on the PU statement or 8192, whichever is smaller.

Considerations

- Can be modified only for subarea stations.
- Only the generated value can be modified.
- The station must be inactive before this field can be modified.
- If BLOCK is not 0, then #PIUs/block must be greater than 0.

Tuning Suggestions

- To prevent multiple-PIU frames from being built, set BLOCK to 0.
- To reduce the number of interframe gaps, set both BLOCK and #PIUs/BLOCK as high as possible.

PIUCHECK GEN (starting with NCP V7R7; subarea stations only)

Generated YES or NO value indicating whether a checksum validation is performed on PIUs sent from and received by this station. Unless tuned, this field is the value from the NCP generation (PIUCHECK keyword on the PU statement).

NDF Default

NO

Considerations

- The station must be inactive before you can modify this value.
- For the checksum validation support to be enabled, the adjacent link station must also have PIUCHECK=YES.

Tuning Suggestions

The PIUCHECK support increases the path length required for NCP to send or receive a PIU, so the PIUCHECK support should be used only when the additional protection is required.

MimWW GEN (starting with NCP V7R8; not applicable to 3746 Model 900 frame-relay logical lines)

Generated lower bound for the IEEE 802.2 LLC working window when reduced for frame loss or BECN. Defined by the *mww* suboperand of the DYNWIND keyword on the LINE or PU statement.

NDF Default

1

Minimum

1

Maximum

127

Considerations

- Applies only to 3745 frame-relay lines.
- Can be modified only for subarea stations.
- The station must be inactive before this field can be modified.

Tuning Suggestions

In most cases, the default value is the best choice. Specify the minimum window value that you want the IEEE 802.2 LLC working window to be reduced to for frame loss and BECN.

SERVICE PRIORITY (starting with NCP V7R7; 3746 Model 900 only)

A relative service priority, at a station level, for the displayed 3746 Model 900 attached frame-relay terminating equipment. Defined by the FRSPRI keyword on the PU statement.

NDF Default

0

Minimum

0

Maximum

3

Considerations

- The physical line must be inactive before this field can be modified.
- See the *3745 Communication Controller Models A, 3746 Nways Multiprotocol Controller Models 900 and 950: Planning Guide, GA33-0457*, for more information about the Model 900 congestion control processing.

Tuning Suggestions

None

PF Keys

F1=HELP

Displays online help for this panel.

F3=RETURN

Returns to the previous NTuneMON panel.

F5=MODIFY

Available when the operator has tuning authority and NTuneNCP is included. For more information, refer to Chapter 5, Using the NTuneNCP Tuning Feature.

Updates the NCP tuning parameter with the modified value. When the modification is not valid, the field turns reverse-video pink and you are prompted to correct the value and resubmit the request.

F6=ROLL

Returns to the NetView command line without exiting NTuneMON. To return to NTuneMON from the NetView program, press F6=ROLL or enter **ATUNEMON** on the NetView command line.

F8=FORWARD

Scrolls forward to ATUFT2 Frame Relay Terminating Equipment Details Page 2, as shown on page 4-143.

F10=HEX

Displays the ATUDP Hexadecimal Storage Display panel, as shown on page 4-68, to show the logical link control block (LLB) for this line.

F12=REFRESH

Refreshes the information on this panel.

ENTER=TG DETAILS

Displays the ATUML Multi-Link Transmission Group panel, as shown on page 6-93, for more information about the transmission group and the origin and destination NCPs.

PA1=EXIT

Exits NTuneMON.

PA2=LOG

Saves the information on this panel to the NetView log.

ATUFT2 Frame Relay Terminating Equipment Details Page 2 Panel

Basic fast-path commands: None

Tuning Fields: COMRATE

```

ATUFT2 A04D1          Frame Relay Terminating      NTuneMON V2R6  12:47
                       Equipment Details Page 2
LLC Status: Link Opened

DLCI      = 17(11)          BECN S SENT      = 0
LINE NAME = J00041FF       BECN R RECEIVED = 0
LINE STATUS= ACTIVE       FECN R RECEIVED = 0
PU NAME   = J0004200       DE BITS SENT     = 0
COMRATE   = ( FULL , 1   ) DE BITS RECEIVED = 49152
                                           FRAMES DISCARDED = 0

Frame Statistics:
DLCI Status      = ACTIVE    ACTIVE
Estimated Bytes  = -         -
Maximum Size Frame = 264     1034
Minimum Size Frame = 15      15
Frames Count     = 0.0/Sec   0.0/Sec
WW / OUTS. FRAME COUNT = 3/0      MAXOUT CUR = 3
N3 / I-Frame Rcv count =          1/0
                                           Minimum working window = 3

=>
F1=HELP F3=RETURN  F4=RESET MIN/MAX F5=MODIFY F6=ROLL F7=BACK F10=HEX
ENTER-TG DETAILS F12=REFRESH/RATES PA1=EXIT PA2=LOG
    
```

Figure 6-15. ATUFT2 Frame Relay Terminating Equipment Details Page 2 Panel

Description

The ATUFT2 Frame Relay Terminating Equipment Details Page 2 panel, which is available for NCP V6R2 or later releases, displays information on the logical line associated with a particular DLCI.

To display this panel: From the ATUFT1 Frame Relay Terminating Equipment Details Page 1 panel, as shown on page 4-135, press F8.

Tuning Fields

COMRATE (FULL|NONE,priority)

Whether certain frames sent by this TESP can be discarded by the frame-relay network. This expedites the processing of other frames when the network is congested. It also specifies the relative transmit priority for a TESP. Defined by the COMRATE keyword on the PU and LINE statements.

COMRATE (FULL|NONE)

Whether certain frames sent by this TESP can be discarded by the frame-relay network to expedite the processing of other frames when the network is congested. Defined by the FULL/NONE suboperand of the COMRATE keyword on the LINE statement.

NDF Default

FULL

Valid Values

- FULL: Specifies that no frames sent by this TESP are discard-eligible.
- NONE: Specifies that all frames sent by this TESP are to be discard-eligible except for the following types:
 - S-frames (RR, RNR, and REJ), including RRs piggybacked on I-frames
 - Network priority frames (virtual route pacing and TG sweep)
 - XIDs

Considerations

- Not modifiable for peripheral stations.
- For 3745 subarea stations, can be modified at any time. The change will be effective the next time a frame is sent.
- For 3746 Model 900 subarea stations, can be modified only when the station is inactive. The change will be effective when the station becomes active.

Tuning Suggestions

Frames in a frame-relay network can be designated as *discard-eligible*. When the network is congested, discard-eligible frames can be discarded to facilitate the processing of frames that are not discard-eligible. Designating frames as not discard-eligible helps ensure that they are transmitted successfully through the network.

COMRATE=FULL should always be used in a frame-relay network that attaches non-SNA devices because these devices will indicate all of their traffic as not discard eligible. COMRATE=NONE should be used in an SNA-only frame-relay network to facilitate throughput.

COMRATE (priority) (NCP V7R2 or later releases)

Relative transmit priority for this TESP as defined by the priority suboperand of the COMRATE keyword on the PU statement.

NDF Default

1

Minimum

1

Maximum

64

Considerations

- The value of the *priority* suboperand is multiplied by the value of the DATABLK keyword on the LINE statement to determine the guaranteed minimum number of bytes that a TESP can transmit before a different TESP must be given a transmission opportunity.
- Not modifiable for peripheral stations.
- For 3745 subarea stations, can be modified at any time. The change will be effective the next time a frame is sent.
- For 3746 Model 900 subarea stations, can be modified only when the station is inactive. The change will be effective when the station becomes active.

Tuning Suggestions

Unless you anticipate high volumes for a TESP, you should specify similar COMRATE values for all TESPs.

PF Keys

F1=HELP

Displays online help for this panel.

F3=RETURN

Returns to the previous NTuneMON panel.

F4=RESET MIN/MAX (NCP V7R3 or later releases)

Available when the operator has tuning authority and NTuneNCP is included. For more information, refer to Chapter 5, Using the NTuneNCP Tuning Feature.

Resets the values of both the transmitted and received Max Size Frame Sent and Min Size Frame Sent fields. After resetting the fields, NTuneMON automatically refreshes the panel. If new traffic rates are available, they are displayed. Otherwise, NTuneMON displays a dash (–) until new traffic rates are available and you press F12 or reenter the panel to display the new rates.

F5=MODIFY

Available when the operator has tuning authority and NTuneNCP is included. For more information, refer to Chapter 5, Using the NTuneNCP Tuning Feature.

Updates the NCP tuning parameter with the modified value. If the modification is not valid, the field turns reverse-video pink and you are prompted to correct the value and resubmit the request.

F6=ROLL

Returns to the NetView command line without exiting NTuneMON. To return to NTuneMON from the NetView program, press F6=ROLL or enter **ATUNEMON** on the NetView command line.

F7=BACK

Scrolls back to ATUFT1 Frame Relay Terminating Equipment Details Page 1 as shown on page 4-135.

F10=HEX

Displays the ATUDP Hexadecimal Storage Display panel, as shown on page 4-68, to show the logical link control block (LLB) for this line.

ENTER=TG DETAILS

Displays the ATUML Multi-Link Transmission Group panel, as shown on page 6-93, for more information about the transmission group and the origin and destination NCPs.

F12=REFRESH/RATES

Refreshes the information on this panel.

PA1=EXIT

Exits NTuneMON.

PA2=LOG

Saves the information on this panel to the NetView log.

ATUGP Network CB Pools/Tables Panel

Basic fast-path commands: None

Tuning fields: GWPACING

```

ATUGP A27GENC      Network CB Pools / Tables      NTuneMON V2R6  14:24
                  NETWORK = NETA                SUBAREA = 27
-----
NETWORK  MAX  CUR  ALERT  MAX  CUR  FREE  FREE  TOTAL  DYNA  PERM
CB POOLS USE  USE  THRSH  USE  USE  UNRSVD RSYD  TOTAL  DYN  ASSGN
-----
GWNAU    0%  0%  80%    0    0    0     0    0     0    0     0
TGB      50% 50%  80%    1    1    1     0    2    N/A   0
TRT      0%  0%  80%    1    1   253    0   254  N/A   0
-----
Max Network Limit = 0
Use Network Count = 0
Subarea Limit     = 511
ER Limit          = 16

GWPACING          = ( 0 , ADAP , ALLOW )
=> _
F1=HELP  F2=CBPOOLS  F3=RETURN  F4=BUFPPOOL  F5=MODI  F6=ROLL  F10=HEX
F12=REFRESH PA1=EXIT PA2=LOG
    
```

Figure 6-16. ATUGP Network CB Pools/Tables Panel

Description

The ATUGP Network CB Pools/Tables panel, which is available beginning with NCP V7R1, monitors network details and enables tuning of unpaced-session parameters. For information on NCP control block pools, see “ATUCB Control Block Pools/Tables Panel” on page 4-17.

To display this panel: On the ATUNG HSCBs and GWNAUs panel, as shown on page 4-195, place the cursor under a network name and press F2.

Tuning Fields

GWPACING

Actions to take during a cross-network session if the BIND request or response indicates that session pacing will not control the flow of data for this session. Defined by the GWPACING keyword on the BUILD or NETWORK statement.

First GWPACING Value

Pacing window size that can override the session pacing parameters in a negotiable BIND for SNA LU-LU cross-network sessions. Defined by the *window* suboperand of the GWPACING keyword.

NDF Default

0

Minimum

0

Maximum

63

Considerations

- 0 is a special value indicating that the pacing window sizes on the negotiable BIND are not overridden.
- This field can be modified at any time. However, the modified values are used only when a new session is established. Sessions that are already established continue to use the values of GWPACING before they were modified. When the session becomes inactive and then active again, the new value is used.

Tuning Suggestions

None

Second GWPACING Value

Action to be taken on BIND for SNA LU-LU cross-network sessions for which adaptive session pacing can be used.

NDF Default

ADAP

Valid Values

ADAP — allows the BIND to pass through unchanged.

FIXED — turns off the adaptive session pacing support bit in the BIND, which prevents adaptive session pacing from being used for this session.

Considerations

This field can be modified at any time. However, the modified values are used only when a new session is established. Sessions that are already established continue to use the values of GWPACING before they were modified. When the session becomes inactive and then active again, the new value is used.

Tuning Suggestions

None

Third GWPACING Value

Action to be taken on nonnegotiable BINDs and negotiable BIND responses for the activation of SNA LU-LU cross-network sessions for which no session pacing will be used.

NDF Default

ALLOW

Valid Values

ALLOW — allows the session activation attempt to proceed.

FAIL — prevents the session activation from proceeding.

Considerations

This field can be modified at any time. However, the modified values are used only when a new session is established. Sessions that are already established continue to use the values of GWPACING before they were modified. When the session becomes inactive and then active again, the new value is used.

Tuning Suggestions

None

PF Keys**F1=HELP**

Displays online help for this panel.

F2=CBPOOLS

Displays the ATUCB Control Block Pools/Tables panel, as shown on page 4-17, to show information on the use of NCP control block pools.

F3=RETURN

Returns to the previous NTuneMON panel.

F4=BUFPOOL

Displays the ATUBP NCP Buffer Pool panel, as shown on page 4-4, to show information on the NCP buffer pool and its subpools.

F6=ROLLReturns to the NetView command line without exiting NTuneMON. To return to NTuneMON from the NetView program, press F6=ROLL or enter **ATUNEMON** on the NetView command line.**F10=HEX**

Displays the ATUDP Hexadecimal Storage Display panel, as shown on page 4-68, to show the queue anchor block (QAB).

F12=REFRESH

Refreshes the information on this panel.

PA1=EXIT

Exits NTuneMON.

PA2=LOG

Saves the information on this panel to the NetView log.

ATUHP HPR & Other Global Flow Control Params Panel

Basic fast-path commands: HP, HPR

Tuning fields: HPRSMPS, HPRSATT, HPRSMLC, Subarea Stage, Rex Stage

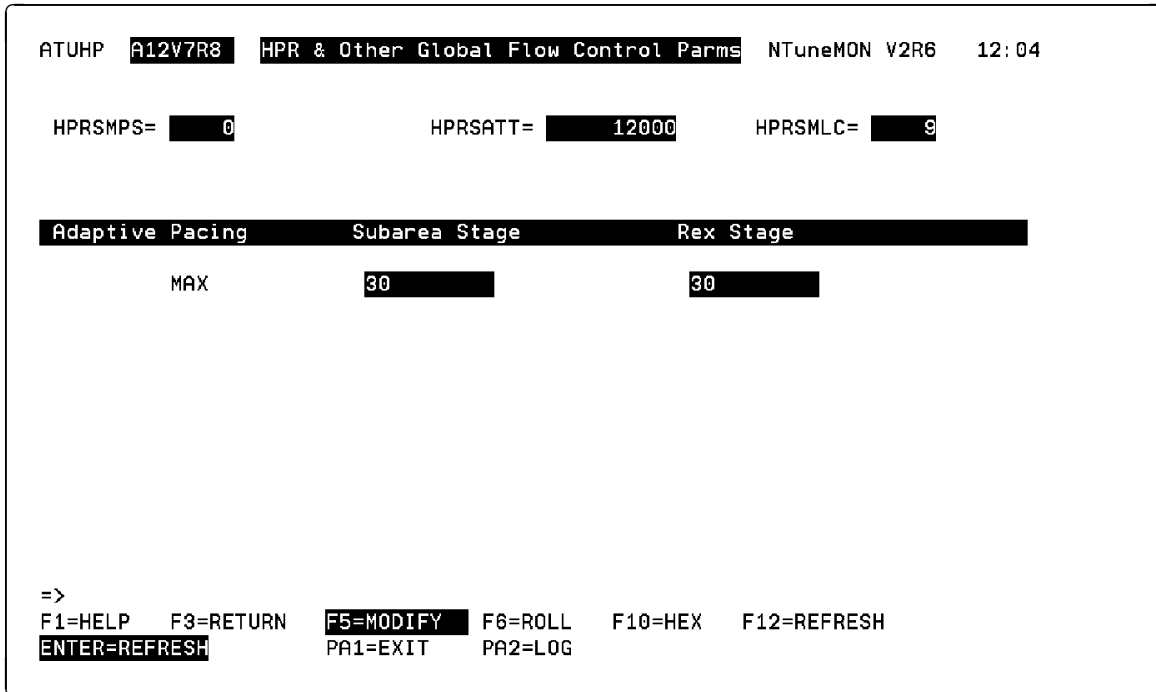

Figure 6-17. ATUHP HPR & Other Global Flow Control Params Panel

Description

The ATUHP HPR & Other Global Flow Control Params panel is available for NCP V7R3 or later releases and only for HPR and APPN resources. It displays information about HPR and other global flow control parameters.

To display this panel: From the ATUBP NCP Buffer Pool panel, as shown on page 4-4, press F7.

Tuning Fields

HPRSMPS

Largest packet that can be sent across the composite ANR node's subarea network without being segmented on any of the subarea links along the path. Defined by the HPRMPS keyword on the BUILD statement.

NDF Default

0

Valid Values

- Table 6-4 on page 6-85 shows the segment size used for each line protocol. If you want to manually calculate the HPRSMPS value for MLTGs, use this table.
- An alternative way to determine the HPRSMPS value is to use NTuneMON to display every TG in your subarea network. Then take the smallest value for each TG from the MAX Transfer field on the ATUML Multi-Link Transmission Group panel.

Table 6-4. Segment Sizes Used by NCP

Line Protocol	Keywords that Affect Segment Size	How to Calculate Segment Size
SDLC	TRANSFR, BFRS	(TRANSFR * BFRS)–18 bytes ¹
Token ring	MAXTSL	MAXTSL value ²
NTRI	RCVBUFC	RCVBUFC value–36 bytes ³
Frame relay	MAXFRAME	MAXFRAME value–16 bytes ⁴

Notes: ¹ The PIU segment size for an SDLC link depends on the TRANSFR value and BFRS value of the adjacent NCP, which are transferred when the XID exchange takes place. Multiply the TRANSFR value of the adjacent NCP by the BFRS value and subtract 18 bytes from the result.

² The PIU segment size for a 3746 model 900 Token Ring or NTRI depends on the MAXTSL value.

³ When you define a NTRI link, you can code RCVBUFC to limit the maximum segment size to be received. NCP uses the smaller of the MAXTSL value of this node or the RCVBUFC–36 value of the adjacent node as the segment size of the NTRI link.

⁴ The PIU segment size for a frame-relay link is the smaller of (1) this link's MAXFRAME–16 or (2) the adjacent node's MAXFRAME–16.

Considerations

Use HPRMPS only if you have downlevel nodes (NCP releases before V7R3) in your network. Make sure that the parameter has the same value throughout the network.

Tuning Suggestions

If the value for HPRSMPS is too large, HPR data will have to be segmented and reassembled as it flows across the subarea network. Always lower the value; never raise it.

HPRSATT

Average accumulated transmission time in microseconds that it takes to route 1200 bits across the composite ANR node's subarea network. Defined by the HPRATT keyword on the BUILD statement.

NDF Default

12000

Valid Values

Table 6-5 on page 6-86 shows the times you should use for various line types and speeds, where times are less than 200 000 microseconds.

Table 6-5. Accumulated Transmission Time by Line Type and Speed

Line Type	Line Speed (bits per second)	Accumulated Transmission Time (microseconds)
Token Ring	–	1736
ESCON Channel	–	843
Type 6 Channel	–	843
Type 7 Channel	–	528
	9600	125000
	19200	62500
	38400	31250
	55855	21485
	64000	18750
SDLC or Frame Relay	245760	4883
	256000	4688
	512000	2344
	1024000	1172
	1536000	782
	1843200	652
	2048000	586

Considerations

- If the typical path traverses an MLTG, do not add up all the accumulated transmission time (ATT) values for links in the MLTG. Use the largest ATT value of any one link in the MLTG as the ATT of the TG.
- If the typical path traverses more than one subarea node, use the sum of all the links along the path.

Tuning Suggestions

It is better (less of an impact) to code this value too large rather than too small. In either case, the RTPs will eventually measure round-trip delay and adjust to the actual measured values; therefore, it is not critical that this value be accurate to the microsecond.

HPRMLC

Minimum link capacity, in kilobits per second, for the slowest subarea transmission group in the composite ANR's subarea network that can carry Advanced Peer-to-Peer Networking (APPN) HPR data. Defined by the HPRMLC keyword on the BUILD statement.

NDF Default

9

Valid Values

Table 6-6 on page 6-87 shows the minimum link capacity by line type and speed.

Table 6-6. Minimum Link Capacity by Line Type and Speed

Line Type	Line Speed (bits per second)	Minimum Link Capacity (kilobits per second)
Token Ring	–	588
ESCON Channel	–	1214
Type 6 Channel	–	1214
Type 7 Channel	–	1939
	75	1
	100	1
	110	1
	134	1
	200	1
	300	1
	600	1
	1200	1
	2400	2
	4800	4
SDLC or Frame Relay	9600	9
	19200	18
	38400	37
	55855	54
	64000	62
	245760	240
	256000	250
	512000	500
	1024000	1000
	1536000	1500
	1843200	1800
	2048000	2000

Considerations

Unlike the ATT, the capacity of a TG is the sum of all the individual link capacities in the TG.

Tuning Suggestions

Coding too small a value might result in RTP restricting traffic rates to unnecessarily low values. It is better to overestimate capacity than to underestimate it.

Subarea Stage

Maximum window size that NCP sets in an adaptive pacing response message (IPM) sent on the subarea stage. Specified by the *max_window_subarea* suboperand of the ADPLIMIT keyword on the BUILD statement.

ATUHP HPR & Other Global Flow Control Params Panel

NDF Default

0

Minimum

0

Maximum

32767

Considerations

- 0 is a special value indicating that this suboperand does not limit the NCP-calculated value.
- Can be modified at any time.

Tuning Suggestions

- For most networks, the default value is appropriate. However, the best choice for this value depends on how a particular network is set up.
- This field should be set to the same value as the Rex Stage field unless there is a well understood reason to do otherwise.

Rex Stage

Maximum window size that NCP sets in an adaptive pacing response message (IPM) sent on the rex stage. Specified by the *max_window_rex* suboperand of the ADPLIMIT keyword on the BUILD statement.

NDF Default

The value of the Subarea Stage field.

Minimum

0

Maximum

32767

Considerations

- 0 is a special value indicating that this suboperand does not limit the NCP-calculated value.
- Can be modified at any time.

Tuning Suggestions

- For most networks, the default value is appropriate. However, the best choice for this value depends on how a particular network is set up.
- This field should be set to the same value as the Subarea Stage field unless there is a well understood reason to do otherwise.

PF Keys

F1=HELP

Displays online help for this panel.

F3=RETURN

Returns to the previous NTuneMON panel.

F5=MODIFY

Available when the operator has tuning authority and NTuneNCP is included. For more information, refer to Chapter 5, Using the NTuneNCP Tuning Feature.

ATUHP HPR & Other Global Flow Control Params Panel

Updates the NCP tuning parameter with the modified value. If the modification is not valid, the field turns reverse-video pink, and you are prompted to correct the value and resubmit it.

F6=ROLL

Returns to the NetView command line without exiting NTuneMON. To return to NTuneMON from the NetView program, press F6=ROLL or enter **ATUNEMON** on the NetView command line.

F10=HEX

Displays the ATUDP Hexadecimal Storage Display panel, as shown on page 4-68, to show the HPR control block.

F12=REFRESH

Refreshes the information on this panel.

ENTER=REFRESH

Refreshes the information on this panel.

PA1=EXIT

Exits NTuneMON.

PA2=LOG

Saves the information on this panel to the NetView log.

ATUID IP Interface Information Detail Panel

Fast-path commands: ID, IPDETAIL (from ATUIS IP Router Statistics Page 1 or, starting with NCP V7R1, ATUIX IP Router Statistics Page 2 panel)

Tuning fields: ARP Address Format

```

ATUID  A71NT06  IP Interface Information Detail  NTuneMON V2R1  16:08
Interface Name      TR89
Interface Address   9.71.90.1      Enter the IP Address of the
                  Interface that you would
                  like to see.
Interface Type      TOKEN-RING      ARP Address Format:  NON-CANONICAL
Type of Connection  DIRECT CONNECT  Gateway Address     N/A
Status              ACTIVE
Broadcast Frames Support YES              Metric              12
Fragmentation Supported NO
MTU Size            150

=> _
F1=HELP F2=IP STATS F3=RETURN F4=IPLIST F5=MODIFY F6=ROLL F7=TR IP STATS
F9=ROUTENT F10=HEX F11=ARP F12=REFRESH PA1=EXIT PA2=LOG
ENTER=SEARCH FOR IP ADDRESS
    
```

Figure 6-18. ATUID IP Interface Information Detail Panel

Description

The ATUID IP Interface Information Detail panel, which is available for NCP V6R1 or later releases, displays information about a specific IP interface.

To display this panel:

- From the ATUCH Channel Adapter Details panel, as shown on page 4-32, press F2.
- From the ATUCL 3746-900 Station Details panel, as shown on page 4-39, press F2.
- From the ATUCI Channel IP Statistics panel, as shown on page 4-36, press Enter.
- From the second PF key set of either the ATUTP1 Token-Ring TIC Details Page 1 panel, as shown on page 4-310, or the ATUTP2 Token-Ring TIC Details Page 2 panel, as shown on page 4-319, press F7.
- From the ATUTI Token-Ring IP Statistics panel, as shown on page 4-298, press Enter.

Note: If you have defined an internal 3746 Model 900 point-to-point IP connection, it is treated as a Token-Ring interface.

- On the ATUIL IP Interface Information panel, as shown on page 4-169, place the cursor under an interface address and press Enter.
- On the ATUIR IP Route Table Entries panel, as shown on page 4-172, place the cursor under an interface address and press Enter.

- From the ATUIA ARP Table Entry panel, as shown on page 4-155, press F2.
- On the ATUEP Ethernet Adapter List panel, as shown on page 4-81, place the cursor under an IP address and press F2.
- On the ATUFA Frame Relay Support List panel, as shown on page 4-88, place the cursor under an IPSP DLCI and press Enter.
- From the ATUFI Frame-Relay IP Link Statistics panel, as shown on page 4-102, press Enter.

See the descriptions of these panels for more information.

If you use the fast-path command from the ATUIS IP Router Statistics Page 1 panel or the ATUIX IP Router Statistics Page 2 panel, then the ATUID IP Interface Information Detail panel displays information about the owning host address.

Tuning Fields

ARP Address Format (starting with NCP V7R1; Token-Ring interfaces)

Format of the hardware address received in ARP packages as defined by the NOTCANON|CANON suboperand of the ARPTAB keyword on the PU statement.

NDF Default

NOTCANON

Valid Values

- **CANONICAL:** Inverted format. In this format, the leftmost byte of the hardware address is transmitted first, and the rightmost bit of each byte is transmitted first.
- **NON-CANONICAL:** Non-inverted format. In this format the leftmost byte of the hardware address is transmitted first, and the leftmost bit of each byte is transmitted first.

Considerations

- Modifiable only if the IP Token-Ring interface is inactive.
- Not modifiable for an internal 3746 Model 900 point-to-point IP interface.

Tuning Suggestions

None

PF Keys

F1=HELP

Displays online help for this panel.

F2=IP STATS

Displays the ATUIS IP Router Statistics Page 1 panel, as shown on page 4-175, to show global counters for IP datagrams and ICMP messages.

F3=RETURN

Returns to the previous NTuneMON panel.

F4=IPLIST

Displays the ATUIL IP Interface Information panel, as shown on page 4-169, to show the local IP interface names and addresses for an NCP.

F5=MODIFY (Token-Ring interfaces)

Available when Interface Type on this panel is Token Ring, the operator has tuning authority, and NTuneNCP is included. For more information, refer to Chapter 5, Using the NTuneNCP Tuning Feature.

Updates the NCP tuning parameter with the modified value. If the modification is not valid, the field turns reverse-video pink, and you are prompted to correct the value and resubmit it.

F6=ROLL

Returns to the NetView command line without exiting NTuneMON. To return to NTuneMON from the NetView program, press F6=ROLL or enter

ATUNEMON on the NetView command line.

F7=TR IP STATS, ENET STATS, FR IP STATS, CH IP STATS

F7=TR IP STATS (starting with NCP V7R1; Token-Ring interfaces): Displays the ATUTI Token-Ring IP Statistics panel, as shown on page 4-298, to show Token-Ring IP statistics.

Note: If you have defined an internal 3746 Model 900 point-to-point IP connection, it is treated as a Token-Ring interface.

F7=ENET STATS (NCP V6R1 or later releases; Ethernet interfaces): Displays the ATUEP Ethernet Adapter List panel, as shown on page 4-81, to show configuration and traffic information on up to 16 Ethernet-type LAN lines. From the ATUEP Ethernet Adapter List panel, you can place the cursor under the line you want to view and press Enter to display the ATUET Ethernet Adapter Statistics panel.

F7=FR IP STATS (NCP V7R3 or later releases for frame-relay interfaces): Displays the ATUFI Frame-Relay IP Link Statistics panel, as shown on page 4-102, to show IP statistics for this frame-relay line.

F7=CH IP STATS (NCP V7R3 or later releases for channel interfaces): Displays the ATUCI Channel IP Statistics panel, as shown on page 4-36, to show IP statistics for this channel.

F9=ROUTENT (starting with NCP V7R1 if a gateway address is defined)

Displays the ATUIR IP Route Table Entries panel, as shown on page 4-172, to show host, network, and subnetwork addresses for a particular destination.

F10=HEX

Displays the ATUDP Hexadecimal Storage Display panel, as shown on page 4-68, to show the local address entry (LAE) control block.

F11=ARP (Token-Ring, Ethernet, frame-relay, and channel interfaces)

Displays the ATUIA ARP Table Entry panel, as shown on page 4-155, to show an ARP entry for this interface.

F12=REFRESH

Refreshes the information on this panel.

PA1=EXIT

Exits NTuneMON.

PA2=LOG

Saves the information on this panel to the NetView log.

ENTER=SEARCH FOR IP ADDRESS

Displays this panel for another IP address. Type in another IP address in the Interface Address field and press Enter.

ATUML Multi-Link Transmission Group Panel

Basic fast-path commands: None

Tuning fields: (TG THRS) LOW, MED, HIGH, TOTAL, PRI, QUED LMT

```

ATUML                               Multi-Link Transmission Group      NTuneMON V2R1  14:57
NCP= A04NT06  SUB= 4                NCP= A71NT06  SUB= 71
TGN= 1      NET= NETA                TGN= 1      NET= NETA
MAX Transfer= 6984                  MAX Transfer= N/A
Outbound SEQ= 001                  Outbound SEQ= N/A
Inbound SEQ= 001                   Inbound SEQ= N/A
Transmit QUE= 0                    Transmit QUE= N/A
----- HIGH PERFORMANCE ROUTING -----
BYTES =          0  QUED LMT= 20000  BYTES =          0  QUED LMT=
DISCARDED FID4S  RXD=0      TXD=0    DISCARDED FID4S  RXD=      TXD=
TG:  LOW:  MED:  HIGH:  TOTAL  TG:  LOW:  MED:  HIGH:  TOTAL
CUR=  0    0    0    0    0    CUR= N/A    N/A    N/A    N/A
THRS= 5000 5000 5000 20000 THRS= N/A    N/A    N/A    N/A

PRI LINE  PU      TYPE  STATUS  PRI LINE  PU      TYPE  STATUS
0  A04TR88  A04LPU88 16MTIC2 ACTIVE  0
0  A04F0003 A04LP10  FRTSS   ACTIVE  0
0  A04F0003 A04LP11  FRTSS   ACTIVE  0
0  A04F0003 A04LP12  FRTSS   ACTIVE  0
0  A04F0003 A04LP13  FRTSS   ACTIVE  0

=>
F1=HELP F3=RETURN F5=MODIFY F6=ROLL F7=BACK F8=FORWARD F10=HEX F12=REFRESH
PA1=EXIT PA2=LOG  ENTER=Fill in destination MLTG data
    
```

Figure 6-19. ATUML Multi-Link Transmission Group Panel

Description

The ATUML Multi-Link Transmission Group panel displays information on a multi-link transmission group. The left side of the panel displays information on the origin NCP, and the right side displays information on the destination NCP.

Note: Information on the destination NCP is displayed only if that NCP is activated by the host in which NTuneMON is running.

To display this panel:

- On the ATUTG Transmission Group panel, as shown on page 4-294, place the cursor under a transmission group and press Enter.
- From the ATUTL Token-Ring SNA Station panel, as shown on page 4-301, press Enter.
- From the ATUSD SDLC Station Details panel, as shown on page 4-241, press Enter.
- From the ATUFT1 Frame Relay Terminating Equipment Details Page 1 panel, as shown on page 4-135, or from the ATUFT2 Frame Relay Terminating Equipment Details Page 2 panel, as shown on page 4-143, press Enter.

Tuning Fields

Note: The tuning fields can be modified only for the origin NCP.

QUED LMT (NCP V7R3 or later releases)

Maximum number of bytes of HPR data allowed to be queued to the MLTG's transmit queue. Defined by the *totthresh* suboperand of the ERn keyword on the PATH statement.

NDF Default

0

Minimum

0

Maximum

16777215 (16M)

Considerations

If QUED LMT is reduced to a value less than BYTES QUED, bytes already on the queue will not be freed.

Tuning Suggestions

If HPR BYTES QUED is too large with respect to TOTAL bytes queued, and the virtual routes in the subarea network are being excessively throttled, reduce QUED LIMIT until it is less than the TG threshold TOTAL.

LOW MED HIGH TOTAL (NCP V4R3.1 or later releases)

For LOW-priority, MEDIUM-priority, and HIGH-priority PIUs, defines the flow-control threshold for PIUs transmitted over this transmission group with that priority. For TOTAL, defines the flow-control threshold for all PIUs transmitted over this transmission group. Defined by the *lothresh*, *medthresh*, *hithresh*, and *totthresh* suboperands of the ERn keyword.

NDF Default

5000 (Low, Medium, and High)

20000 (Total)

Minimum

1 – The TG threshold TOTAL must be greater than the low, medium, or high threshold values.

Maximum

524288 – Low, Medium, and High threshold values

2097152 – Total threshold value. If threshold value is over 100 000, it displays as a multiple of 1024 bytes (where k equals 1024 bytes). For example, 2097152 would display as 2097k. The value truncates and does not round off.

Considerations

- Request to modify may fail if dynamic path update (DPU) or TG INOP caused the transmission group control block (TGB) to be freed.
- If counts exceed thresholds, NCP sets virtual route pacing indicators in the PIUs sent to the destination subareas, which will effectively slow down the flow of PIUs.

- The effect of modifying the TG threshold value depends on the type of network:
 - Non-dynamic network: Modified value applies only to the specified TG and network and will start being used immediately.
 - Reference Network: The modified TG threshold is used for that TG by any dynamic network that is subsequently activated.
 - Dynamic network: The modified TG threshold value is used immediately and remains in use for that TG until the dynamic network is deactivated. If the dynamic network is reactivated, the value from the reference network will be used to initialize the TG threshold, overwriting the modified value.

Tuning Suggestions

- Increase the TG threshold value if throughput is low and none of the NCPs at the virtual route end-points are in danger of going into slowdown.
- Decrease the TG threshold value if PIU traffic is flooding NCPs at the virtual route end-points. (The virtual route end-point could also be a VTAM, rather than an NCP.)

PRI (NCP V6R1 or later releases)

Assigns a priority to a line in a multilink transmission group (MLTG), which controls the order in which stations on a MLTG are chosen for transmission of PIUs. Defined by the MLTGPR1 keyword on the LINE statement. Numbers are prioritized from high to low. If the numbers are the same, the line that is activated first has priority.

NDF Default

0

Minimum

0

Maximum

255

Considerations

- NCP selects higher priority lines before lower priority lines when you code MLTGORDR=MLTGPR1 on the BUILD statement. If you code MLTGORDR=FIFO on the BUILD statement or if you do not code MLTGORDR, MLTGPR1 is ignored, and in these cases, PRI will not be modifiable.
- **The modified value is used only when a station is *added* to the MLTG.** Stations already in the MLTG will continue to use the value of *PRI* before it was modified. When the station becomes inactive and then active again, the new value is used.

Tuning Suggestions

Higher speed TGs stations, or more reliable TGs stations should be coded with higher values than lower speed or less reliable TGs stations in the same MLTG.

PF Keys

F1=HELP

Displays online help for this panel.

F3=RETURN

Returns to the previous NTuneMON panel.

F5=MODIFY

Available when the operator has tuning authority, and NTuneNCP is included. For more information, refer to Chapter 5, Using the NTuneNCP Tuning Feature.

Updates the NCP tuning parameter with the modified value. If the modification is not valid, the field turns reverse-video pink, and you are prompted to correct the value and resubmit it.

F6=ROLL

Returns to the NetView command line without exiting NTuneMON. To return to NTuneMON from the NetView program, press F6=ROLL or enter **ATUNEMON** on the NetView command line.

F7=BACK

Scrolls the panel data backward one screen.

F8=FORWARD

Scrolls the panel data forward one screen.

F10=HEX

Displays the ATUDP Hexadecimal Storage Display panel, as shown on page 4-68, to show the multilink transmission group control block (FLB) for the origin or destination NCP. Place the cursor in the half of the panel for the NCP you want to view and press F10.

F12=REFRESH

Refreshes the information on this panel.

PA1=EXIT

Exits NTuneMON.

PA2=LOG

Saves the information on this panel to the NetView log.

ENTER=FILL IN DESTINATION MLTG DATA

Displays line-specific information for the destination NCP. The destination NCP is found as follows: If the PUNAME and NEWNAME keywords on the BUILD statement are not equal, a search is made using PUNAME. If PUNAME is not found, a search is made using NEWNAME.

Destination data is filled in on the right half of the panel only when the destination NCP was activated on the host in which NTuneMON is running.

After you press Enter the first time, ENTER has the same function as F12=REFRESH.

ATUMT Modify Timer Value Panel

Basic fast-path commands: None

Tuning fields: REPLYTO, RETRYTO, TEXTTO, XMITDLY

```

ATUMT  A71NT05          Modify Timer Value          NTuneMON V2R1  07:34
-----
Timer Value Select Table (TVS)
Time-out Value (in seconds) for REPLYTO = 60.0
-----
| 1.  NONE | 2.  0.0 | 9.  6.5 | 10. 30.0 |
|-----|-----|-----|-----|
| 3.  1.0 | 4.  2.2 | 11. 0.1 | 12. █████ |
|-----|-----|-----|-----|
| 5.  3.0 | 6. 23.5 | 13.     | 14.     |
|-----|-----|-----|-----|
| 7. 60.0 | 8.  4.2 | 15.     | 16.     |
|-----|-----|-----|-----|
=>
F1=HELP  F3=RETURN  F4=SELECT TIMER,RETURN  F5=MODIFY  F6=ROLL  F10=HEX
F12=REFRESH  PA1=EXIT  PA2=LOG
    
```

Figure 6-20. ATUMT Modify Timer Value Panel

Description

The ATUMT Modify Timer Value panel, which is available for NCP V7R2 or later releases, displays information about time-out values, in seconds, for the time value select (TVS) control block. This panel is also used to enter new timer values for a particular keyword. All defined entries are displayed in white.

To display this panel: On the ATUSP2 SDLC Peripheral Line Parameters Page 2 panel, as shown on page 4-255, place the cursor under the REPLYTO, RETRYTO, TEXTTO, or XMITDLY keyword and press F9.

How to Modify Time-Out Values

You must select the timer you want to change from ATUSP2 by pressing F9=MOD TIMER. The ATUMT Modify Timer Value panel appears. The ATUMT Modify Timer Value panel allows you to either create a new timer value or select an existing one.

Attention: You are allowed to create only 16 entries for each timer. Once an entry is created, it can never be changed until you regenerate the NCP. Once all available entries are created, no new timer values can be added. You cannot duplicate entries. Before creating a new entry, examine closely the existing entries to see if one of them can be used instead of creating a new one.

How to Select an Existing Timer Value

To select an existing timer value, complete the following steps:

1. Place the cursor under the timer value you want to select.
2. Press F4=SELECT TIMER,RETURN. Pressing F4 returns you to the ATUSP2 panel. The value you selected on ATUMT is now on the ATUSP2 panel and a message appears indicating that the timer value was successfully verified. It has not, however, been modified yet. When you press F4=MODIFY,ACT or F5=MODIFY from the ATUSP2 panel, the new timer value will be modified in conjunction with any other changes you might have made on ATUSP1 and ATUSP2.

How to Create a New Timer Value

To create a new timer value, complete the following steps:

1. Place the cursor under the blank entry that is highlighted in reverse-video turquoise.
2. Type in the new value. See each timer keyword for valid values and defaults.
3. Press F5=MODIFY. A warning message appears indicating that the timer value will be a permanent entry. This message prompts you to type either *Y* or *N* to accept this value or reject it.
4. Type *Y* to accept the value and press Enter. The newly created value is now displayed in white.
5. Place the cursor under the timer value you just created.
6. Press F4=SELECT TIMER,RETURN. Pressing F4 returns you the ATUSP2 panel. The value you selected on ATUMT is now on the ATUSP2 panel and a message appears indicating that the timer value was successfully verified. It has not, however, been modified yet. When you press F4=MODIFY,ACT or F5=MODIFY from the ATUSP2 panel, the new timer value will be modified in conjunction with any other changes you might have made on ATUSP1 and ATUSP2.

Tuning Fields

Time-out Value (in seconds) for nn = vv.v

Displays timer value vv.v for timer keyword nn, the timer whose timer value is being modified. The timer keywords whose values can be modified using the ATUMT Modify Timer Value panel are:

- REPLYTO
- RETRYTO
- TEXTTO
- XMITDLY

The current value of the keyword, as well as its matching value in the corresponding timer entry, is displayed in pink. The following paragraphs describe the parameters for each panel:

REPLYTO

Reply time-out value or values for the lines in this group, as defined by the REPLYTO on the GROUP statement. When NCP or EP does not receive a response to a poll, selection, or message text before the specified time

expires, a time-out error is indicated and the appropriate error recovery procedure is started.

For switched SDLC line, NCP uses the interval specified by XMITDLY on this GROUP statement as the reply time-out value during initial XID exchange. In other cases, NCP uses the value of REPLYTO.

Minimum

0

Maximum

60

See "ATUSP2 SDLC Peripheral Line Parameters Page 2 Panel" on page 4-255 for additional information about modifying REPLYTO.

RETRYTO

Specifies, in seconds, how long NCP is to wait after receiving a retry call progress signal (CPS) before retrying a call out, as defined by the RETRYTO keyword on the GROUP statement.

Minimum

0

Maximum

1632

See "ATUSP2 SDLC Peripheral Line Parameters Page 2 Panel" on page 4-255 for additional information about modifying RETRYTO.

TEXTTO

Text time-out value, in seconds, for the line, as defined by the TEXTTO keyword on the GROUP statement.

Minimum

0

Maximum

1632

See "ATUSP2 SDLC Peripheral Line Parameters Page 2 Panel" on page 4-255 for additional information about modifying TEXTTO.

XMITDLY

Specifies, in seconds, how long NCP is to delay its initial transmission after answering an incoming call, as defined by the XMITDLY keyword on the GROUP statement.

The value of XMITDLY is used as the reply time-out value during initial XID exchange.

Minimum

The value of REPLYTO or 1 if REPLYTO is NONE.

Maximum

60

See "ATUSP2 SDLC Peripheral Line Parameters Page 2 Panel" on page 4-255 for additional information about modifying XMITDLY.

Time-Out Values (in seconds)

Timer entry containing *nn.n*

nn.n specifies defined entries. *nn.n* is also the time-out value in seconds.

To choose one of the existing timer entries, place the cursor on that entry and press F4.

Timer entry containing a reverse-video turquoise box

The first available entry for modifying. The entry is displayed in reverse-video turquoise.

To create a new timer value, place the cursor on the entry which is currently displayed in reverse-video turquoise. Type in the desired timer value and press F4.

If no entry is shown in reverse-video turquoise, all entries are already defined and no new values can be added.

Blank timer entry

The timer entries which are blank represent available timer entries. At a particular time, only the first available entry will be modifiable.

Attention: Once an entry is defined, it can never be changed. Once all the available entries are defined, no new timer values can be added; but you can still switch between existing values. The number of timer entries are limited. Therefore, before defining a new entry, consider carefully whether or not an existing entry could be used.

PF Keys

F1=HELP

Displays online help for this panel.

F3=RETURN

Returns to the previous NTuneMON panel.

F4=SELECT TIMER VALUE,RETURN

Available when the operator has tuning authority and NTuneNCP is included.

Returns you to the ATUSP2 SDLC Peripheral Line Parameters Page 2 panel. The value you selected on the ATUMT Modify Timer Value panel is now on the ATUSP2 SDLC Peripheral Line Parameters Page 2 panel and a message appears indicating that the timer value was successfully verified. If has not, however, been modified yet. When you press F4=MODIFY,ACT or F5=MODIFY from either the ATUSP1 SDLC Peripheral Line Parameters Page 1 or the ATUSP2 SDLC Peripheral Line Parameters Page 2 panel, the new timer value will be modified in conjunction with any other changes you might have made on the ATUSP1 SDLC Peripheral Line Parameters Page 1 and ATUSP2 SDLC Peripheral Line Parameters Page 2 panels.

F5=MODIFY

Available when the operator has tuning authority and if NTuneNCP is included.

Adds a permanent timer value to an existing entry in NCP's timer value select (TVS) control block. The value appears as a defined value on this panel. A warning message appears indicating that the timer value will be a permanent entry and you are prompted to type Y or N to either accept or reject the value.

Note: You are only allowed to create sixteen entries for each timer. Once an entry is created, no new timer values can be added. You cannot duplicate entries. Before creating a new entry, examine closely the existing entries to see if one of them can be used instead of creating a new one.

F6=ROLL

Returns to the NetView command line without exiting NTuneMON. To return to NTuneMON from the NetView program, press F6=ROLL or enter **ATUNEMON** on the NetView command line.

F10=HEX

Displays the ATUDP Hexadecimal Storage Display panel, as shown on page 4-68, to show the TVS.

F12=REFRESH

Refreshes the information on this panel.

PA1=EXIT

Exits NTuneMON.

PA2=LOG

Saves the information on this panel to the NetView log.

ATUPL SDLC Physical Line Details Panel

Basic fast-path commands: See "The PL Fast-Path Command."
Tuning fields: Line Speed, HISPEED, LSPRI, CLOCKNG, PAUSE, NRZI, SERVLIM

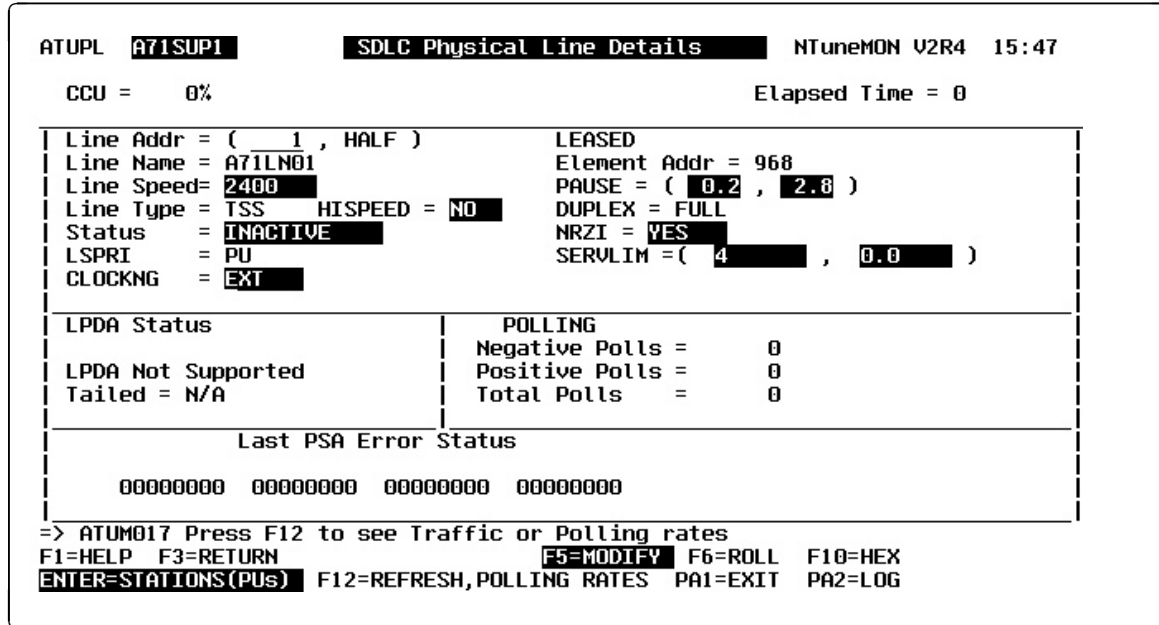

Figure 6-21. ATUPL SDLC Physical Line Details Panel

Description

The ATUPL SDLC Physical Line Details panel displays detailed information for a SDLC physical line (TSS, HPTSS, or CLP).

To display this panel:

- On the ATUFC Physical Line List panel, as shown on page 4-94, place the cursor under an SDLC line and press Enter.
- From the ATUSP1 SDLC Peripheral Line Parameters Page 1 panel, as shown on page 4-249, or from the ATUSP2 SDLC Peripheral Line Parameters Page 2 panel, as shown on page 4-255, press F11.

The PL Fast-Path Command

To access the ATUPL SDLC Physical Line Details panel from any NTuneMON panel (except help panels), use the PL fast-path command. The following diagram shows the syntax of the PL fast-path command and its operands. The *ncpname* operand is optional, but if it is specified it must precede the *address* operand. The *address* operand is required.

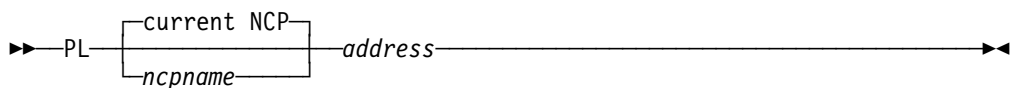

ncpname The name of the NCP as defined in the NCP gen. If this operand is omitted, NTuneMON uses the NCP name that is displayed on the top of the panel where the PL command is entered.

address The address of the SDLC link as defined by the ADDRESS keyword on the LINE definition statement.

Tuning Fields

Note: IF MONLINK=CONTINUOUS was coded for subarea line, the line might not stay inactive long enough for you to modify parameters.

Line Speed (NCP V4R3.1 or later releases)

Data rate for a line in bits per second, as defined by the *rate* suboperand of the SPEED keyword on the LINE statement. This data rate is the rate at which the devices communicate with the communication controller.

NDF Default

None

Valid Values

The line speed that is actually used by NCP might differ from the line speed that you enter on this panel. To see the line speeds that NCP uses, and to decide which speed value you should specify, refer to the discussion of the SPEED keyword on the LINE statement in the *Resource Definition Reference* manual. The remainder of this "Valid Values" section discusses the **SPEED value that is displayed by NTuneMON**.

Beginning with NCP V7R7, NTuneMON displays the SPEED value exactly as you coded it in the gen or modified it on this panel.

For NCP V7R6 and earlier releases,

- See Table 6-7 on page 6-104 to find the displayed values for SPEED for SDLC lines (TSS and HPTSS). These values are valid only for NCP V5R4 and later.
- See Table 6-8 on page 6-104 to find the displayed speed values for the 3746 Model 900 when CLOCKNG=INT or CLOCKNG=DIRECT.
- See Table 6-9 on page 6-105 to find the displayed speed values for the 3746 Model 900 when CLOCKNG=EXT. When CLOCKNG=EXT, SPEED values for 3746 Model 900 SDLC lines can be tuned to any value from 600 to 2048000. However, for NCP V7R6 and earlier, after you enter the value, it is converted and displayed as shown in Table 6-9.

Values that can be displayed but cannot be entered are:

NOT DEFIN

SPEED has not been coded or tuned to a valid value.

RPQ

SPEED is a non-standard value set by a special arrangement with IBM.

ATUPL SDLC Physical Line Details Panel

Table 6-7. Displayed SPEED Values for 3745 SDLC Lines (TSS and HPTSS) when VERSION<V7R7

Data Rate (SPEED) ¹	CLOCKNG=INT	CLOCKNG=DIRECT	CLOCKNG=EXT ³
50	■	■	■
75		■	■
100		■	■
110	■	■	■
134	■	■	■
200	■	■	■
300	■	■	■
600	■	■	■
1200	■	■	■
2400	■	■	■
4800	■	■	■
9600		■	■
19200		■	■
38400		■	■
55855		■	■
245760		■	■
1843200 ²		■	■

Notes:

- 1 For NCP V4R3.1 and earlier, the speed is displayed as "N/A".
- 2 This speed is valid only for HPTSS lines.
- 3 If you specified a value other than the ones shown in this table, the value you specified will be displayed as follows: If the value is less than 1843200, the panel displays the next highest valid value in the table. For example, if 60 was specified, the panel display will be 75. If a value greater than 1843200 was specified for SPEED, the panel display will be 1843200.

Table 6-8. Displayed SPEED Values for 3746 Model 900 when CLOCKNG=INT or CLOCKNG=DIRECT and VERSION<V7R7

Data Rate (SPEED)	CLOCKNG=INT	CLOCKNG=DIRECT
600	■	■
1200	■	■
2400	■	■
4800	■	■
9600		■
19200		■
32000		
38400		■
55855		■
64000		■
256000		■
512000		■
1024000		■
1536000		■
2048000		■

Table 6-9. Displayed SPEED Values for 3746 Model 900 SDLC Lines When CLOCKNG=EXT and VERSION<V7R7

Actual Data Rate (SPEED) Value for CLOCKNG=EXT	Converted and Displayed on This Panel as SPEED Value:
>= 600 and <= 32000	19200
> 32000 and <= 64000	38400
> 64000 and <= 256000	256000
> 256000	512000

Considerations

- For the 3745, can be modified at any time.
- For the 3746 Model 900, the line must be inactive before this field can be modified.
- Not modifiable for subarea.

Tuning Suggestions

- If you use NPM, specify SPEED to ensure that line utilization is correctly calculated. Define SPEED as the clocking rate provided by the external source. If this line is attached to a dual-rate modem, specify the higher of the two rates for SPEED.

Notes:

1. When you modify SPEED you also need to modify the NPM speed value so that utilization is still calculated correctly.
 2. SPEED should also be kept accurate for lines that support HPR traffic.
- When this LINE statement represents a multiple-terminal-access line used to communicate with terminals of different speeds, specify the speed of any of the terminals. For example, if terminals operating at speeds of 110 bps and 134.5 bps use this line, specify either SPEED=110 or SPEED=134.

HISPEED (NCP V4R3.1 or later releases)

Whether the TSS line operates at speeds of 144 Kbps or greater, as defined by the HISPEED keyword on the LINE statement.

NDF Default

When the value of SPEED on this LINE statement is 144000 or greater, the default is HISPEED=YES; otherwise, the default is HISPEED=NO.

Valid Values

- YES: TSS line speed >= 144 Kbps.
- NO: TSS line speed < 144 Kbps.

Considerations

- Valid only for TSS lines (line address 0-895).
- The line must be inactive before this field can be modified.
- When HISPEED=YES, the ADDRESS keyword on this LINE statement can specify any address on the scanner, but only one line in the scanner can operate at once.

ATUPL SDLC Physical Line Details Panel

- You must code HISPEED=YES to operate a 256-Kbps line attached to a TSS adapter. If you do not, the line remains pending contact and no error message is issued.

Tuning Suggestions

Set HISPEED appropriately for the actual speed of the physical line. HISPEED is a configuration parameter, rather than a tuning parameter, and after it is set, it should not need to be modified again.

LSPRI (NCP V4R3.1 or later releases)

Whether transmission priority should be used to determine the order in which PIUs are sent to the PU, as defined by the LSPRI keyword on the LINE statement.

NDF Default

PU

Valid Values

- LSPRI=NO: Specifies that transmission is not to be used as the basis of transmission order. PIUs are transmitted in the order in which they are received.
- LSPRI=PU: Specifies that the link outbound queue (LOBQ) is to be prioritized for each PU on the line. The priority of sessions across the PU is based on the transmission priority of virtual routes associated with these sessions.
- LSPRI=LINK: Replaces the service order table (SOT) with a prioritized queue used for transmission of *all* PIUs across the link. The SOT is still used for polling.

LSPRI=LINK is valid for the following conditions:

- T1 or T2 PUs on either duplex lines or half-duplex lines on which HDXSP=YES on the LINE statement
- LNCTL=SDLC on the LINE statement for peripheral links

Considerations

- If LSPRI=LINK, performance might be degraded because this overrides PASSLIM.
- Line must be a peripheral link.
- If HDXSP=NO (the NDF default or as coded by the user) and ADDRESS=HALF, as defined by LINE statement, the value of LSPRI cannot be modified to LINK.
- The line must be inactive before you can modify LSPRI when:
 - The value of LSPRI is modified to *LINK*
 - The current value of this field is *LINK*.

Tuning Suggestions

None

CLOCKNG (tunable starting with NCP V7R7)

Whether the modem (data set) or the communication scanner for the line provides the clocking. Defined by the CLOCKNG keyword on the LINE statement.

NDF Default

EXT

Valid Values

- DIRECT: The scanner provides clocking and propagates it to the attached DTE. The data signal received by the controller is synchronized with the controller's clock. You must use a directly attached cable.
- EXT: The modem or other external source provides clocking. You can use either a directly attached cable or a modem cable.
- INT: The scanner provides clocking but does not propagate it to the attached DTE. The scanner synchronizes the received data signal; a different clock is used at each end of a link. You can use either a directly attached cable (no modem) or a modem cable.

Considerations

- The line must be inactive before this field can be modified.
- The node can be either subarea or peripheral.
- If LPDATS is not equal to NO or X21NTWK is not equal to NO, then only CLOCKNG=EXT is valid.
- If LPDA2DL=YES, NEWSYNC=YES, or X21SW=YES, then only CLOCKNG=EXT is valid.
- How CLOCKNG is coded affects which values are valid on SPEED. The valid SPEED values for SDLC lines are shown in Table 6-7 on page 6-104, Table 6-8 on page 6-104, and Table 6-9 on page 6-105. After you modify CLOCKNG, if SPEED and CLOCKNG are not compatible, both fields are highlighted in pink and an error message is issued.

Tuning Suggestions

Code CLOCKNG appropriately for this line's configuration.

PAUSE(t1, t2) (NCP V4R3.1 or later releases)

Delay in seconds between successive polling cycles, as defined by the PAUSE keyword on the LINE statement.

PAUSE(t1) (NCP V4R3.1 or later releases)

The pause for this line if the line is operating as a modulo-8 line. Defined by the t1 suboperand of the PAUSE keyword on the LINE statement.

NDF Default

0.2

Minimum

0.0

Maximum

25.5

PAUSE(t2) (NCP V4R3.1 or later releases)

The pause for this line if the line is operating as a modulo-128 line. Defined by the *t2* suboperand of the PAUSE keyword on the LINE statement.

NDF Default

0.8

Minimum

0.0

Maximum

25.5

Considerations

- This field is *not* modifiable for point-to-point subarea CLP lines.
- This field *is* modifiable for other CLP lines, if the line is inactive. The modified value is used when the line becomes active.
- For non-CLP lines, the modified value is used at the next polling cycle.
- When you generate a subarea link, the value of the REPLYTO keyword in the primary NCP should be greater than the value of the PAUSE keyword in the secondary NCP.
- If HDXSP=YES and ADDRESS=HALF, as defined on the LINE statement, neither *t1* nor *t2* can be modified.
- For Point-to-point subarea lines, the modified value is used until the value is modified again or the station becomes inactive. When the station is brought back up, the original generation value is used.
- For all other lines, the modified value is used unless it is modified again.
- On subarea stations, a PAUSE value that is greater on the secondary station than the REPLYTO value of the primary station can negatively affect performance and cause temporary errors.
- Setting PAUSE to a very high value can cause performance and tuning problems.

Note: If, as a consequence of modifying MAXOUT for a station, NTuneMON with NTuneNCP modifies the value of MODULO, the user may also want to modify the PAUSE value corresponding to the new MODULO. Refer to the MAXOUT keyword on the “ATUSD SDLC Station Details Panel” on page 6-113, for additional information.

Tuning Suggestions

- In a primary NCP, if a polling cycle equals or exceeds the PAUSE limit, the next polling cycle begins immediately. If the polling cycle is shorter than the PAUSE limit, the beginning of the next polling cycle is deferred until the PAUSE time has elapsed.
- Decrease the PAUSE value if PIUs have a high traffic volume; increase the value when traffic volume is lower.
- If traffic is restricted, set PAUSE= (average SOT Scan Time).
- Allowing a pause to elapse when activity on the link is relatively low can reduce the amount of processing time consumed by unproductive polling.
- You can improve performance of HPTSS lines by defining a pause of at least one second for a secondary NCP.

- For large subarea configurations (for example, over 500 lines coded), the PAUSE value for the secondary state must be at least 0.5 second.
- Code different values for the primary and secondary NCPs.

NRZI (NCP V4R3.1 or later releases)

YES or NO to specify whether the data terminal equipment at the SDLC link must operate in a non-return-to-zero change-on-ones mode (YES) or in a non-return-to-zero mode (NO). Defined by the NRZI keyword on the LINE statement.

NDF Default

YES

Valid Values

- YES: Operate in non-return-to-zero change-on-ones mode (also known as non-return-to-zero inverted).
- NO: Operate in non-return-to-zero mode.

Considerations

- The line must be inactive before this field can be modified.
- The value of NRZI must be the same at both ends of the link. Mixing of modes on the same SDLC link results in total lack of communication between stations on the link.

Tuning Suggestions

- NRZI is a configuration parameter, rather than a tuning parameter, and once set correctly, it should not need to be modified.
- Set NRZI to match the attached modem:
 - Code NRZI=NO for most non-IBM modems and all IBM 5812 and 5822 data set units.
 - Code NRZI=YES for IBM modems.
 - If external (modem) clocking is used on the link, specify NRZI=YES or omit the keyword unless the modem is sensitive to repeated binary one-zero patterns (that is, 10101010...). Sensitivity to this pattern can cause the modem to lose synchronism when it encounters sufficiently long sequences of this pattern in message data. If the modem is sensitive to this bit pattern, specify NRZI=NO.

SERVLIM Scan Limit (NCP V4R3.1 or later releases)

The first value after SERVLIM= is the SERVLIM scan limit. This specifies the maximum number of regular scans of the service order table (SOT) that NCP is to make for normal servicing of physical and logical units on the link before it makes a special scan of the SOT. The SERVLIM scan limit is defined by the *entries* suboperand of the SERVLIM keyword on the LINE or SDLCST statement.

NDF Default

4

Minimum

1

ATUPL SDLC Physical Line Details Panel

Maximum

255

Considerations

- This field is *not* modifiable for point-to-point subarea CLP lines.
- This field *is* modifiable for other CLP lines, if the line is inactive. The modified value will be used when the line becomes active.
- If DIAL=NO on the GROUP statement, the SERVLIM scan limit is not valid when you specify MODE=SECONDARY on the GROUP statement.
- The SERVLIM scan limit is used primarily for multipoint links, but it can be modified for any SDLC line displayed by this panel.
- For TSS and HPTSS, the modified value will be used when a new polling cycle is started.
- For multipoint lines, a high SERVLIM scan limit can cause long delays in the recovery or activation of the remote station.

Tuning Suggestions

Base your selection of a SERVLIM scan limit on:

- The relative number of status commands the access method issues for the link served by the SOT.
- The relative importance of the following alternatives:
 - A lower SERVLIM scan limit gives NCP more frequent opportunities to fulfill accumulated status commands. Such status commands are fulfilled more promptly, but at the cost of frequent interruptions to normal servicing.
 - A higher SERVLIM scan limit causes fewer interruptions to normal servicing of devices but delays fulfillment of the status commands.
- Experience.

You can minimize the possibility of throughput degradation by coding a high scan limit for SERVLIM or a low value for REPLYTO, or both.

SERVLIM Timer (starting with NCP V7R4)

The second value after SERVLIM= is the SERVLIM timer value. This specifies the maximum time, in seconds, that NCP spends making regular scans of the service order table (SOT) before making a special scan of the SOT. The SERVLIM timer value is defined by the *seconds* suboperand of the SERVLIM keyword on the LINE or SDLCST statement.

NDF Default

If no SERVLIM timer value is defined, the frequency of special scans is determined solely by the SERVLIM scan limit parameter.

Minimum

1.0

Maximum

600.0

Considerations

- This field is *not* modifiable for point-to-point subarea CLP lines.
- This field *is* modifiable for other CLP lines, if the line is inactive. The modified value will be used when the line becomes active.
- If DIAL=NO on the GROUP statement, the SERVLIM timer value is not valid when you specify MODE=SECONDARY on the GROUP statement.
- The SERVLIM timer value is used primarily for multipoint links, but it can be modified for any SDLC line displayed by this panel.
- For TSS and HPTSS, the modified value will be used when a new polling cycle is started.
- For multipoint lines, a high SERVLIM timer value can cause long delays in the recovery or activation of the remote station.

Tuning Suggestions

Base your selection of a SERVLIM timer value on:

- The relative number of status commands the access method issues for the link served by the SOT.
- The relative importance of the following alternatives:
 - A lower SERVLIM timer value gives NCP more frequent opportunities to fulfill accumulated status commands. Such status commands are fulfilled more promptly but at the cost of frequent interruptions to normal servicing.
 - A higher SERVLIM timer value causes fewer interruptions to normal servicing of devices but delays fulfillment of the status commands.
- Experience.

You can minimize the possibility of throughput degradation by coding a high timer value for SERVLIM or a low value for REPLYTO, or both.

PF Keys

F1=HELP

Displays online help for this panel.

F3=RETURN

Returns to the previous NTuneMON panel.

F4=SDLC PN PARMS

Displays the ATUSP1 SDLC Peripheral Line Parameters Page 1 panel, as shown on page 4-249, to show configuration parameters for the line.

F5=MODIFY

Available when the operator has tuning authority and NTuneNCP is included. For more information, refer to Chapter 5, Using the NTuneNCP Tuning Feature.

Updates the NCP tuning parameter with the modified value. If the modification is not valid, the field turns reverse-video pink, and you are prompted to correct the value and resubmit it.

ATUPL SDLC Physical Line Details Panel

F6=ROLL

Returns to the NetView command line without exiting NTuneMON. To return to NTuneMON from the NetView program, press F6=ROLL or enter **ATUNEMON** on the NetView command line.

F10=HEX

Displays the ATUDP Hexadecimal Storage Display panel, as shown on page 4-68, to show the line control block (LKB) for this line.

ENTER=STATIONS(PUs)

Displays the ATUSL SDLC Stations List panel, as shown on page 4-246, which shows the stations associated with the physical line.

F12=REFRESH/POLLING RATES

Refreshes the information on this panel to display polls per second instead of the number of polls since the last time the poll counter field wrapped.

PA1=EXIT

Exits NTuneMON.

PA2=LOG

Saves the information on this panel to the NetView log.

ATUSD SDLC Station Details Panel

Basic fast-path commands: None

Tuning fields: #PIUs/BLOCK, STATION, CONGESTION, RETRIES, PASSLIM, MAXDATA GEN, MAXOUT GEN, BLOCK GEN, PIUCHECK GEN, HPRQLIMIT

```

ATUSD A13SVTB          SDLC Station Details          NTuneMON V2R5    11:22
PU NAME = A13P48      SUBAREA = 4      NETID = NETA      Elapsed Time = 0
PU STATUS = ACTIVE    NCP ROLE = PRIMARY  TG = 2
#PIUs/BLOCK = 0      STATION = NORMAL   Subarea PU
CONGESTION = NONE    MODE = NORMAL

```

FRAME STATISTICS:	TRANSMIT	RECEIVE	CUR:	GEN:
TOTAL FRAMES	6073 -	2766 -	PASSLIM = 254	-
TOTAL I-FRAMES	4349 -	2338 -	MAXDATA = 521	521
OUTSTANDING FRAME CNT:	1	-	MAXOUT = 8	8
			BLOCK = 0	0
			PIUCHECK= NO	NO

```

RETRIES = ( 7 , 0 , 0 )

POLLING
Negative Polls = 196
Positive Polls = 1022
Total Polls = 1218

```

=> ATUM017 Press F12 to see Traffic or Polling rates
F1=HELP F3=RETURN F5=MODIFY F6=ROLL F10=HEX F12=REFRESH/TRAFFIC RATES
ENTER=TG DETAILS(SUBAREA ONLY) PA1=EXIT PA2=LOG

Figure 6-22. ATUSD SDLC Station Details Panel

Description

The ATUSD SDLC Station Details panel displays detailed information on a particular SDLC station.

To display this panel: On the ATUSL SDLC Stations List panel, as shown on page 4-246, place the cursor under a station and press Enter.

Tuning Fields

Notes:

1. The value in the GEN fields is either the value from the NCP generation statement or the value determined by subsequent NCP processing.
2. The value in the CUR fields is a working value which is either initially set or limited by the value in the corresponding GEN field.

#PIUs/BLOCK (NCP V5R4 or later releases; subarea stations)

Maximum number of PIUs for multiple-PIU frames as defined by the *pius* sub-operand of the BLOCK keyword on the PU statement.

NDF Default

If the value of *bytes* (BLOCK) is 0, the default is 0; otherwise, the default is 8.

Minimum

2—this value can be 0 if the value of *bytes* (BLOCK) is 0.

Maximum

16

Considerations

- Subarea stations only.
- If BLOCK is not 0, then #PIUs/BLOCK must be greater than 0.

Tuning Suggestions

To reduce the number of interframe gaps, set the values, both BLOCK and #PIUs/BLOCK, as high as possible.

STATION (starting with NCP V7R6)

Whether the station can be used for hot standby (STANDBY) or cannot (NORMAL), as defined by the TGCONF keyword on the PU definition statement.

NDF Default

NORMAL

Valid Values

- NORMAL: The station can transmit data anytime data is queued for transmission.
- STANDBY: The station is reserved for use as a hot-standby station. STANDBY is not valid if no TGCONF keyword or TGCONF=SINGLE was coded on the PU definition statement.

Considerations

- This field applies only to a transmission group subarea link station.
- The station must be inactive before this field can be modified.

Tuning Suggestions

None.

CONGESTION (starting with NCP V7R6)

The station's role in congestion relief as defined by the third parameter of the TGCONF keyword on the PU definition statement:

- If the station can be used to relieve congestion, this field displays the station's threshold percentage.
- If the station can be used as a standby station but not to relieve congestion, this field displays NONE.
- If the station cannot be used as a standby station, this field displays N/A.

NDF Default

NONE

Valid Values

- 3, 6, 12, 25, 50, 75, 87, 93, 97, or 100: Defines the congestion threshold as a percentage of the *totthresh* parameter coded on the ERn keyword on the associated PATH statement. When this congestion threshold is exceeded, the standby station will help transmit data until the congestion is relieved.
- NONE: The station will not be used to relieve congestion. NONE is required when the STATION field displays NORMAL or when SINGLE was coded as the first parameter of the TGCONF keyword on the PU statement.

Considerations

- This field applies only to a transmission group subarea link station that has been designated as hot-standby station (TGCONF=STANDBY).
- The station must be inactive before this field can be modified.
- The standby station can transmit data when this congestion threshold is exceeded.

Tuning Suggestions

None.

RETRIES(m, t, n)

Number of attempts to be made to recover from errors occurring during transmission over the link. Each attempt at recovery, or *retry*, is a retransmission of data or control commands. NCP performs retries until the transmission is successful or the number of retries reaches the maximum specified by this keyword.

Retries are performed in sets, which are called *retry sequences*. NCP can perform one or more retry sequences. Successive retry sequences are separated by pauses. You can specify the number of retries in a sequence (*m*), the number of sequences to be performed (*n*), and the length of the pause between sequences (*t*). The maximum number of retries NCP attempts equals $(m + 1) \times (n + 1) - 1$.

Note: *m* is *not* modifiable from this panel. However, for peripheral stations, *m* can be modified from the ATUSP2 SDLC Peripheral Line Parameters Page 2 panel, as shown on page 6-134.

Defined by the RETRIES keyword on the PU statement.

RETRIES(t) (NCP V4R3.1 or later releases)

Pause interval, in seconds, between successive retry sequences, as defined by the *t* suboperand of the RETRIES keyword on the PU statement.

NDF Default

0

Minimum

0

Maximum

255

ATUSD SDLC Station Details Panel

RETRIES(n) (NCP V4R3.1 or later releases)

Maximum number of retry sequences, as defined by the *n* suboperand of the RETRIES keyword on the PU statement.

NDF Default

0 or 1

Minimum

0

Maximum

127

Considerations

- The station must be inactive before this field can be modified.
- This field is *not* modifiable for switched stations.
- This field is *not* modifiable for subarea stations on a point-to-point line.
- For leased multipoint subarea stations, the station must be reset.
- For leased peripheral stations, the station must be reset and must not have been DR-added or DR-deleted.
- If $((n+1)*m) > 128$, the change is allowed, but *m* and *n* are highlighted in reverse-video pink.
- If $m=0$, then *t* and *n* must be zero.
- If MODE=SEC, and the station is on a multipoint line, then *t* and *n* are not modifiable because 0 is the only valid value.

Note: For SDLC peripheral lines, *m* is modifiable from the ATUSP2 SDLC Peripheral Line Parameters Page 2 panel, as shown on page 6-134. Once *m* is updated, *t* and *n* can be updated correspondingly from the ATUSD panel.

Tuning Suggestions

None

PASSLIM (NCP V4R3.1 or later releases)

Maximum number of consecutive PIUs that NCP will send at one time to a device, as defined by the PASSLIM keyword on the PU statement. When the PASSLIM value is reached, NCP services the next entry in the SOT.

NDF Default

PU statement:

- 254 – Type 4 PU
- 1 – Type 1 or type 2 PU

SDLCST statement:

- 254

Minimum

1

Maximum

254

Considerations

- PASSLIM is not required when you define a type 2.1 PU. Type 2.1 PUs create a value for PASSLIM in their format 3 XID exchange; however, NCP can adjust the value of PASSLIM to control the maximum number of consecutive PIUs it sends at one time to the type 2.1 PU. NCP uses the smaller of the XID and the generated value for PASSLIM.
- Switched station:
 - This field is not modifiable for switched stations.
- Leased subarea station on a multipoint link:
 - Only the current (CUR) value can be modified.
 - For a PU associated with a multipoint line operating in duplex mode (that is, FULL is the value of the second suboperand of ADDRESS on the LINE definition statement), if the value you specify for PASSLIM is greater than the MAXOUT value, the line might be forced to operate in half-duplex mode.
- Leased subarea station on a point-to-point link:
 - The station must be active before this field can be modified.
 - Only the current value can be modified.
- Leased peripheral stations:

To modify the current value:

 - The station must be active.
 - The station cannot be DR-added or DR-deleted.

To modify the generated value:

 - The station must be inactive.
 - The station cannot be DR-added or DR-deleted.

Notes:

1. When you modify the generated value, NTuneMON also modifies the PASSLIM current field with the same value.
 2. The value of PASSLIM may be adjusted by NCP to control the maximum number of consecutive PIUs that NCP sends at one time to the type 2.1 PU. NCP uses either the XID-generated value of MAXOUT or the system generation value of PASSLIM, whichever is smaller.
- 3746 Model 900
 - The station must be active before this field can be modified.
 - Only the current (CUR) value can be modified.
 - This field is not modifiable for point-to-point subarea links.

Tuning Suggestions

- Set PASSLIM to a value that allows all the PIUs of a segmented message to be transmitted in a single polling pass. This can prevent a single PU from monopolizing a link shared by other PUs.
- If a single PU is defined in the SOT, code PASSLIM=254.
- PASSLIM > MAXOUT hurts response time.
- Set PASSLIM lower for PUs that have mainly batch traffic.

MAXDATA GEN (NCP V5R4 or later releases)

Maximum number of bytes this PU can send or receive in one data transfer.

NDF Default

Leased Subarea Station: If not coded, MAXDATA is not considered when determining segment size on an MLTG.

Leased Peripheral Station: See Minimum.

Minimum

Leased Subarea Station: 26 + (Value of BFRS on the BUILD statement)

Leased Peripheral Station: 9 + (Value of BFRS on the BUILD statement)

Maximum

65535

Considerations

- Only the generated value can be modified.
- The station must be a leased subarea or a leased peripheral station (DIAL=NO on the GROUP statement).
- Leased Subarea Stations:
 - The station must be inactive before this field can be modified.
 - If you do not code MAXDATA, NCP does not take MAXDATA into consideration when calculating segment size for a multilink transmission group. Refer to the discussion of multilink transmission groups in *NCP, SSP, and EP Resource Definition Guide* for more information on using MAXDATA to coordinate segment size for different line control protocols in a multilink transmission group.
- Leased Peripheral Stations:
 - The station must not be DR-added or DR-deleted.
 - The station must be inactive before this field can be modified.
 - XID exchanges must not be supported by the station, as defined by XID=NO on the PU statement.

Tuning Suggestions

- For leased subarea, set MAXDATA to the smallest segment size used by any link in the MLTG, thereby eliminating transmission problems due to incompatible segment sizes for different links in the MLTG.
- Set MAXDATA as large as possible for a device, to minimize segmentation.
- MAXDATA should be a multiple of the BFRS keyword on the BUILD statement. This optimizes the transmitted frame size to a minimum number of segmented frames because NCP will segment PIUs into multiples of NCP buffers. In addition, consider the 9 bytes required for the TH and RH for peripheral stations and the 26 bytes required for the TH for subarea stations.

MAXOUT GEN (NCP V4R3.1 or later releases)

Type 1 or Type 2 PU: Number of unacknowledged information frames NCP can have outstanding for this PU before requiring a response.

Type 4 PU: Maximum number of information frames NCP is to send before a response is required.

NDF Default

For MODULO 8: 1 for peripheral, 7 for subarea
 For MODULO 128: 8

Minimum

For MODULO 8: 1
 For MODULO 128: 8

Maximum

For MODULO 8: 7
 For MODULO 128: 127

Considerations

- Only the generated MAXOUT value can be modified.
- When MAXOUT is modified, MODULO is set accordingly, to 8 or 128. Refer to Table 5-1 on page 5-7 for additional information.
- Code a MAXOUT value that can be supported by the physical device. Some devices do not support MODULO 128.
- Switched station: This field cannot be modified.
- Leased subarea station: The station must be inactive before this field can be modified.
- Leased peripheral station:
 - The station must be inactive before this field can be modified.
 - The station cannot be DR-added or DR-deleted.

Tuning Suggestions

- If retransmissions exist and MAXOUT is high, lower MAXOUT.
- A high MAXOUT (7 or 127, depending on MODULO) can reduce the number of acknowledgements and time spent waiting for acknowledgements but might increase the number of PIUs that must be retransmitted in a retry sequence.

BLOCK GEN (NCP V5R4 or later releases)

Maximum size in bytes for frames transmitted over this subarea. Defined by the *bytes* suboperand of the BLOCK keyword.

NDF Default

0

Minimum/Default

0

Maximum

8192

This value must be less than or equal to the value of MAXDATA on the PU statement or 8192, whichever is smaller.

Considerations

- Only the generated BLOCK value can be modified.
- Valid only for subarea stations.

ATUSD SDLC Station Details Panel

- The station must be inactive before this field can be modified.
- If BLOCK is not 0, then #PIUs/BLOCK must be greater than 0.

Tuning Suggestions

- To prevent multiple-PIU frames from being built, set BLOCK to 0.
- To reduce the number of interframe gaps, set both BLOCK and #PIUs/BLOCK as high as possible.

PIUCHECK GEN (starting with NCP V7R7; subarea stations only)

Generated YES or NO value indicating whether a checksum validation is performed on PIUs sent from and received by this station. Unless tuned, this field is the value from the NCP generation (PIUCHECK keyword on the PU statement).

NDF Default

NO

Considerations

- The station must be inactive before you can modify this value.
- For the checksum validation support to be enabled, the adjacent link station must also have PIUCHECK=YES.

Tuning Suggestions

The PIUCHECK support increases the path length required for NCP to send or receive a PIU, so the PIUCHECK support should be used only when the additional protection is required.

HPRQLIMIT (NCP V7R3 or later releases; peripheral stations)

Number of bytes of HPR data that can be queued to the peripheral link station's transmission queue at one time, as defined by the HPRQLIM keyword on the PU statement.

NDF Default

0 – No limit to the amount of HPR data that can be queued

Minimum

0

Maximum

16777215

Considerations

Peripheral stations only.

Tuning Suggestions

HPR flow control generally prevents excessive queuing in NCP, and the default is usually sufficient. For unreliable links, 20000 might provide a safe limit which is low enough to prevent buffer depletion yet high enough to keep from adversely affecting HPR flow control.

PF Keys

F1=HELP

Displays online help for this panel.

F3=RETURN

Returns to the previous NTuneMON panel.

F5=MODIFY

Available when the operator has tuning authority and NTuneNCP is included. For more information, refer to Chapter 5, Using the NTuneNCP Tuning Feature.

Updates the NCP tuning parameter with the modified value. If the modification is not valid, the field turns reverse-video pink, and you are prompted to correct the value and resubmit it.

F6=ROLL

Returns to the NetView command line without exiting NTuneMON. To return to NTuneMON from the NetView program, press F6=ROLL or enter **ATUNEMON** on the NetView command line.

F10=HEX

Displays the ATUDP Hexadecimal Storage Display panel, as shown on page 4-68, to show the common PU control block (CUB) for peripheral stations or the ESCA station control block (SCB) for subarea stations.

F12=REFRESH/TRAFFIC RATES

Refreshes the information on this panel to display polls per second instead of the number of polls since the last time the poll counter field wrapped.

ENTER=TG DETAILS (SUBAREA ONLY)

Displays the ATUML Multi-Link Transmission Group panel, as shown on page 6-93, to show more information about the transmission group and the origin and destination NCPs.

PA1=EXIT

Exits NTuneMON.

PA2=LOG

Saves the information on this panel to the NetView log.

ATUSP1 SDLC Peripheral Line Parameters Page 1 Panel

Basic fast-path commands: None

Tuning fields: NCP USE, VTAM USE, ANSTONE, CCLID, CLOCKNG, DATRATE, DUPLEX, HISPEED, NEWSYNC, NRZI, RING, SPEED, TRANSFR, X21NTWK

```

ATUSP1  A71NT05                               NTuneMON V2R1   07:27
          SDLC Peripheral Line Parameters Page 1

Configuration Parameters for Line A71LN36  Element Address 0022

Status      = INACTIVE                          Line Type = TSS
NCP USE     = NON-REDEF                          Line Addr = ( 36 , FULL )
VTAM USE    = NON-REDEF

ANSTONE     = N/A                               MODE      = PRI
AUTO        = N/A                               NEWSYNC   = NO
CCLID       = N/A                               NRZI      = NO
CLOCKNG     = EXT                               RING      = N/A
DATRATE     = LOW                              SPEED     = 2400
DIAL        = NO                               TRANSFR   = 205
DUPLEX      = FULL                             V25BIS   = NO
HISPEED     = NO                               X21NTWK  = NO
LPDATS     = NO                               X21SW    = NO
LPDA2DL    = NO

=> ATUM704 Use VERIFY before MODIFY,ACT or MODIFY. See HELP (F1).
F1=HELP F2=VERIFY F3=RETURN F4=MODIFY,ACT F5=MODIFY F6=ROLL F8=FORWARD
ENTER=STATIONS(PUs) F10=HEX F11=LINE DETAILS F12=REFRESH PA1=EXIT PA2=LOG
    
```

Figure 6-23. ATUSP1 SDLC Peripheral Line Parameters Page 1 Panel

Description

The ATUSP1 SDLC Peripheral Line Parameters Page 1 panel and the ATUSP2 SDLC Peripheral Line Parameters Page 2 panel, as shown on page 6-134, can be used together to display and update information about various parameters for SDLC peripheral lines.

The ATUSP1 SDLC Peripheral Line Parameters Page 1 panel displays and allows you to update information about various configuration parameters. You can use this panel to change SDLC lines from spare to redefinable (REDEF) or from redefinable to spare. This panel is also used to activate or deactivate lines.

To display this panel:

- On the ATUFC Physical Line List panel, as shown on page 4-94, place the cursor under a peripheral SDLC line and press F4.
- From the ATUPL SDLC Physical Line Details panel, as shown on page 4-217, press F4.
- From the ATUSP2 SDLC Peripheral Line Parameters Page 2 panel, as shown on page 4-255, press F7.

Notes:

1. Configuration parameters, once set correctly, should not need to be modified.
2. F5=MODIFY updates NCP with all the current changes on both the ATUSP1 SDLC Peripheral Line Parameters Page 1 and the ATUSP2 SDLC Peripheral Line Parameters Page 2 panels.
3. None of the parameters on these panels is modifiable unless the line is inactive.
4. If N/A is displayed in the panel field, the field is *not* shown in reverse video turquoise and is *not* modifiable.

Tuning Fields

NCP USE (NCP V7R2 or later releases)

Current use of the line from NCP's perspective, as defined by the USE keyword on the LINE statement.

NDF Default

NCP

Valid Values

- REDEF: The line is currently in use but is capable of being changed to a Spare line.
- SPARE: The line is not currently in use and cannot be activated unless it is first modified to a REDEF line.

Notes:

1. REDEF (redefinable)
2. You cannot specify NON-REDEF. NON-REDEF means the line is currently in use and is not capable of being changed to a SPARE line.

Considerations

- The line must be inactive before this field can be modified.
- This field cannot be modified if the line is non-redefinable.
- If NCP USE is modified, VTAM USE will be modified to match NCP USE, even if you do not explicitly modify VTAM USE.

Tuning Suggestions

- As long as a line is defined to NCP as spare, activation requests to that line will fail.
- To actually start using a line that is currently spare, update line parameters and modify NCP USE to redefinable. Press F4 to activate the line.
- To prevent future activation of a line that is currently redefinable, press F4 to deactivate the line and modify NCP USE to spare.
- See Chapter 7, "Procedure for Adding SDLC Lines" on page 7-1, for details about this function.

VTAM USE (VTAM V4R2 and later releases with appropriate maintenance)

Current use of the line from VTAM's perspective, as defined by the USE keyword on the LINE statement.

Valid Values

- REDEF: The line is currently in use but is capable of being changed to a Spare line.
- SPARE: The line is not currently in use and will not be activated by VTAM unless it is first modified to a REDEF line.

Notes:

1. REDEF (redefinable)
2. You cannot specify NON-REDEF. NON-REDEF means that the line is currently in use and is not capable of being changed to a SPARE line.
3. If VTAM USE does not match NCP USE, modify VTAM USE to match NCP USE.
4. If VTAM does not attempt to activate a particular line that you expect VTAM should activate, check your VTAM USE statement.

Considerations

- If the line is non-redefinable, this field *cannot* be modified.
- If VTAM USE and NCP USE do not match, VTAM USE is displayed in reverse-video pink.
- If VTAM does not support USE, VTAM USE is *not* displayed.
- This field can be modified regardless of the status of the line.
- If you modify NCP USE, VTAM USE will be modified to match NCP USE, even if you do not explicitly modify VTAM USE.

Tuning Suggestions

- If VTAM USE=SPARE, VTAM will not attempt to activate the line, regardless of NCP USE. Note that VTAM USE could be used to prevent a particular VTAM from activating a particular line while still allowing other VTAMs to activate the line.
- If VTAM USE is not SPARE, but NCP=SPARE, VTAM might attempt to activate the line. However, NCP will fail the request for activation. This is why it is important for VTAM USE and NCP USE to be consistent.

ANSTONE (NCP V4R3.1 or later releases)

Whether NCP transmits an answer tone to the calling device to signify completion of the line connection. Defined by the ANSTONE keyword on the LINE statement. Used only for incoming calls on switched lines.

NDF Default

NO

Valid Values

- YES: NCP transmits an answer tone because the modem does not send one.
- NO: NCP does not transmit an answer tone because the modem provides one.

Considerations

- The line must be inactive before this field can be modified.
- If DIAL=NO or X21SW=YES, then ANSTONE does *not* apply.

Tuning Suggestions

If in doubt as to whether the modem supplies a tone, consult the supplier or installer of the modem.

CCLID (NCP V4R3.1 or later releases)

Whether NCP supports called-calling ID (CCLID), as defined by the CCLID keyword on the LINE statement. Used for switched X.21 lines.

NDF Default

NO

Valid Values

- YES: NCP supports CCLID.
- NO: NCP does not support CCLID.

Considerations

- The line must be inactive before this field can be modified.
- If X21SW=NO, then CCLID does *not* apply.

Tuning Suggestions

None

CLOCKNG (NCP V4R3.1 or later releases)

Whether the modem (data set) or the communication scanner for the line provides the clocking. Defined by the CLOCKNG keyword on the LINE statement.

NDF Default

EXT

Valid Values

- DIRECT: The scanner provides clocking and propagates it to the attached DTE. The data signal received by the controller is synchronized with the controller's clock. You must use a directly attached cable.
- EXT: The modem or other external source provides clocking. You can use either a directly attached cable or a modem cable.
- INT: The scanner provides clocking but does not propagate it to the attached DTE. The scanner synchronizes the received data signal; a different clock is used at each end of a link. You can use either a directly attached cable (no modem) or a modem cable.

Considerations

- The line must be inactive before this field can be modified.
- If X21SW=YES, LPDATS is not equal to NO, or LPDA2DL=YES, then CLOCKNG is *not* modifiable.
- If DIAL=NO and X21NTWK is not equal to NO, then only CLOCKNG=EXT is valid.
- If NEWSYNC=YES, then only CLOCKNG=EXT is valid.

- How CLOCKNG is coded affects which values are valid on SPEED. The valid SPEED values for SDLC lines are shown in Table 6-10 on page 6-130, Table 6-11 on page 6-130, and Table 6-12 on page 6-131. After you modify CLOCKNG, if SPEED and CLOCKNG are not compatible, both fields are highlighted in pink and an error message is issued.

Tuning Suggestions

Code CLOCKNG appropriately for this line's configuration.

DATRATE (NCP V4R3.1 or later releases)

Data rate that NCP is to use for a link attached to a dual-rate modem, as defined by the DATRATE keyword on the LINE statement.

NDF Default

LOW

Valid Values

- HIGH: Use the higher rate.
- LOW: Use the lower rate.

Considerations

- The line must be inactive before this field can be modified.
- If CLOCKNG=DIRECT is specified, then only DATRATE=LOW is valid.
- DATRATE does not have an effect if the modem has only one data rate.

Tuning Suggestions

If possible, use the higher rate.

DUPLEX (NCP V4R3.1 or later releases)

Whether the communication line and modem constitute a half-duplex or a duplex facility, as defined by the DUPLEX keyword on the LINE statement.

Duplex is applicable only when Line Addr=(n, HALF). DUPLEX=HALF means the RTS signal is active only when NCP is sending data. DUPLEX=FULL means the RTS signal is active when NCP is sending or receiving data.

Note: Do not confuse this with half-duplex or duplex data transfer. DUPLEX specifies only the physical characteristics of the communication facility and is used to control the request-to-send (RTS) signal.

NDF Default

HALF

Valid Values

- HALF: RTS signal is active only when NCP is sending data.
- FULL: RTS signal is active when NCP is sending or receiving data.

Considerations

- The line must be inactive before this field can be modified.
- DUPLEX is *not* modifiable if the following conditions are true:
 - Line Addr=(nnnn,FULL)
 - Line Addr=(nnnn,HALF) and MODE=SEC

Tuning Suggestions

If the hardware supports it, use DUPLEX=FULL to enhance performance.

HISPEED (NCP V4R3.1 or later releases)

Whether this TSS line operates at speeds of 144 Kbps or greater, as defined by the HISPEED keyword on the LINE statement.

NDF Default

When the value of the SPEED keyword on this LINE statement is 144000 or greater, the default is HISPEED=YES; otherwise, the default is HISPEED=NO.

Valid Values

- YES: TSS line speed >= 144 Kbps.
- NO: TSS line speed < 144 Kbps.

Considerations

- Valid only for TSS lines (line address 0-895).
- The line must be inactive before this field can be modified.
- If HISPEED=YES, the ADDRESS keyword on this statement can specify any address on the scanner, but only one line in the scanner can operate at once.
- You must code HISPEED=YES to operate a 256 Kbps line attached to a TSS adapter. If you do not, the line remains pending contact and no error message is issued.

Tuning Suggestions

Set HISPEED appropriately for the actual speed of the physical line.

NEWSYNC (NCP V4R3.1 or later releases)

Whether the communication controller supplies the new-sync signal to the modem (data set) on this line. Defined by the NEWSYNC keyword on the LINE statement.

NDF Default

NO

Valid Values

- YES: The communication controller supplies the NEWSYNC signal.
- NO: The communication controller does *not* supply the NEWSYNC signal.

Considerations

- The line must be inactive before this field can be modified.
- If X21SW=YES or MODE=SEC, then you cannot modify NEWSYNC because only NEWSYNC=NO is valid.
- If DIAL=NO and X21NTWK is not equal to NO, then NEWSYNC must be NO.
- If DIAL=YES, then NEWSYNC does *not* apply.
- If CLOCKNG is not equal to EXT or if DUPLEX=HALF, then NEWSYNC must be *NO*.
- Code NEWSYNC=YES only if the following apply:
 - The modem (at the controller) serving the line has the new-sync feature.

- The communication controller is the multipoint primary device for a duplex line.
- The modem at the link-attached device does not continuously send carrier signals to the modem at the controller.
- The modem at the link-attached station can send a continuous carrier signal, or the station can send a continuous RTS to the modem.

Tuning Suggestions

Consult your IBM representative or the installer of the modem for further information about these signals.

NRZI (NCP V4R3.1 or later releases)

YES or NO to specify whether the DTE at the end of the SDLC link must operate in non-return-to-zero change-on-ones mode (YES) or in non-return-to-zero mode (NO). Defined by the NRZI keyword on the LINE statement.

NDF Default

YES

Valid Values

- YES: Operate in non-return-to-zero modify-on-ones mode (also known as non-return-to-zero inverted).
- NO: Operate in non-return-to-zero mode.

Considerations

- The line must be inactive before this field can be modified.
- The value of NRZI must be the same at both ends of the link. Mixing of modes on the same SDLC link results in total lack of communication between stations on the link.

Tuning Suggestions

Set NRZI to match the attached modem:

- Code NRZI=NO for most non-IBM modems and all IBM 5812 and 5822 data set units.
- Code NRZI=YES for IBM modems.
- If external (modem) clocking is used on the link, specify NRZI=YES unless the modem is sensitive to repeated binary one-zero patterns (for example, 10101010...). Sensitivity to this pattern can cause the modem to lose synchronization when it encounters sufficiently long sequences of this pattern in message data. If the modem is sensitive to this bit pattern, specify NRZI=NO.

RING (NCP V4R3.1 or later releases)

Whether the ring-indicator mode of an automatic answer operation is used. Defined by the RING keyword on the LINE statement. This decision depends upon the type of modem (data set) that connects the link to the controller.

NDF Default

NO

Valid Values

- YES: Ring indicator mode is used.
- NO: Ring indicator mode is not used.

Considerations

- The line must be inactive before this field can be modified.
- If DIAL=NO or X21SW=YES, then RING does not apply.
- If LPDA2DL=YES, then RING is not modifiable because only RING=YES is valid.
- If the modem has the ring-indicator interface, code RING=YES. If it does not, or if X21SW=YES on the GROUP definition statement, code RING=NO.
- If you code LPDA2DL=YES on LINE, specify RING=YES. If you code LPDA2DL=YES and either CALL=IN or CALL=INOUT, RING=YES is the default and RING=NO is not valid. Note that CALL is a VTAM-only keyword when LNCTL=SDLC and the default is CALL=NO.

Tuning Suggestion

Code RING appropriately for the modem the line is attached to.

SPEED (NCP V4R3.1 or later releases)

Data rate for a line in bits per second, as defined by the *rate* suboperand of the SPEED keyword on the LINE statement. This data rate is the rate at which the devices communicate with the communication controller.

NDF Default

None

Valid Values

The line speed that is actually used by NCP might differ from the line speed that you enter on this panel. To see the line speeds that NCP uses, and to decide which speed value you should specify, refer to the discussion of the SPEED keyword on the LINE statement in the *Resource Definition Reference* manual. The remainder of this "Valid Values" section discusses the **SPEED value that is displayed by NTuneMON**.

Beginning with NCP V7R7, NTuneMON displays the SPEED value exactly as you coded it in the gen or modified it on this panel.

For NCP V7R6 and earlier releases,

- See Table 6-10 on page 6-130 to find the displayed values for SPEED for SDLC lines (TSS and HPTSS). These values are valid only for NCP V5R4 and later, running on a 3745.
- See Table 6-11 on page 6-130 to find the displayed speed values for the 3746 Model 900 when CLOCKNG=INT or CLOCKNG=DIRECT.
- See Table 6-12 on page 6-131 to find the displayed speed values for the 3746 Model 900 when CLOCKNG=EXT. When CLOCKNG=EXT, SPEED values for 3746 Model 900 SDLC lines can be tuned to any value from 600 to 2048000. However, for NCP V7R6 and earlier, after you enter the value, it is converted and displayed as shown in Table 6-12.

Values that can be displayed but cannot be entered are:

NOT DEFIN

SPEED has not been coded or tuned to a valid value.

RPQ

SPEED is a non-standard value set by a special arrangement with IBM.

Table 6-10. Displayed SPEED Values for SDLC Lines (TSS and HPTSS) when VERSION<V7R7

Data Rate (SPEED)	CLOCKNG=INT	CLOCKNG=DIRECT	CLOCKNG=EXT ²
50	■	■	■
75		■	■
100		■	■
110	■	■	■
134	■	■	■
200	■	■	■
300	■	■	■
600	■	■	■
1200	■	■	■
2400	■	■	■
4800	■	■	■
9600		■	■
19200		■	■
38400		■	■
55855		■	■
245760		■	■
1843200 ¹		■	■

Notes:

¹ This speed is valid only for HPTSS lines.

² If you specified a value other than the ones shown in this table, the value you specified will be displayed as follows: If the value is less than 1843200, the panel displays the next highest valid value in the table. For example, if 60 was specified, the panel display will be 75. If a value greater than 1843200 was specified for SPEED, the panel display will be 1843200.

Table 6-11 (Page 1 of 2). Displayed SPEED Values for 3746 Model 900 SDLC Lines when CLOCKNG=INT or CLOCKNG=DIRECT and VERSION<V7R7

Data Rate (SPEED)	CLOCKNG=INT	CLOCKNG=DIRECT
600	■	■
1200	■	■
2400	■	■
4800	■	■
9600		■
19200		■
32000		
38400		■
55855		■
64000		■
256000		■
512000		■
1024000		■

Table 6-11 (Page 2 of 2). Displayed SPEED Values for 3746 Model 900 SDLC Lines when CLOCKNG=INT or CLOCKNG=DIRECT and VERSION<V7R7

Data Rate (SPEED)	CLOCKNG=INT	CLOCKNG=DIRECT
1536000		■
2048000		■

Table 6-12. Displayed SPEED Values for 3746 Model 900 SDLC Lines When CLOCKNG=EXT and VERSION<V7R7

Displayed SPEED Value	Actual Data Rate (SPEED) Values for CLOCKNG=EXT
19200	>= 600 and <= 32000
38400	> 32000 and <= 64000
256000	> 64000 and <= 256000
512000	> 256000

Considerations

- The line must be inactive before this field can be modified.

Tuning Suggestions

- If you use NPM, specify SPEED to ensure that line utilization is correctly calculated. Define SPEED as the clocking rate provided by the external source. If this line is attached to a dual-rate modem, specify the higher of the two rates for SPEED.
- SPEED should also be kept accurate for lines that support HPR traffic.
- If this LINE statement represents a multiple-terminal-access line used to communicate with terminals of different speeds, specify the speed of any of the terminals. For example, if terminals operating at speeds of 110 bps and 134.5 bps use this line, specify either SPEED=110 or SPEED=134.

TRANSFR (NCP V4R3.1 or later releases)

Number of NCP buffers corresponding to the maximum amount of data (the data transfer limit) that NCP can receive from the line during a single data transfer operation. Defined by the TRANSFR keyword on the LINE statement.

NDF Default

Value of TRANSFR on the BUILD statement

Minimum

1

Maximum

254

Considerations

- The line must be inactive before this field can be modified.
- TRANSFR * the NCP buffer size (the BFRS keyword on the BUILD statement) must be >= 559.

Tuning Suggestions

None

X21NTWK (NCP V4R3.1 or later releases)

Specifies whether this line is attached to an X.21 network and specifies the level of the X.21 network. Defined by the X21NTWK keyword on the GROUP statement.

NDF Default

NO

Valid Values

- NO: The line is not attached to an X.21 network.
- OLD: The X.21 network is at a pre-1984 level.
- 1984: The X.21 network is at the 1984 level.

Considerations

- The line must be inactive before this field can be modified.
- If LPDATS is not equal to NO or LPDA2L=YES, then X21NTWK is *not* modifiable because only X21NTWK=NO is valid.
- If DIAL=YES and X21NTWK=NO, then X21NTWK cannot be modified.
- If DIAL=YES and X21NTWK is either OLD or 1984, then you cannot change X21NTWK to NO. X21NTWK=NO is not valid for an X.21 switched line.
- If X21NTWK is not equal to NO, then only the following values are valid:
 - CLOCKNG=EXT
 - NEWSYNC=NO
 - RING=NO
 - ANSTONE=NO

Tuning Suggestions

- If the line is not attached to an X.21 network, set X21NTWK to NO.
- Set X21NTWK to 1984 if the line is attached to a 1984 level X.21 network or to OLD if the X.21 network is at a pre-1984 level.

PF Keys

F1=HELP

Displays online help for this panel.

F2=VERIFY

Available when the operator has tuning authority and NTuneNCP is included.

Verifies that all the changes made on the ATUSP1 SDLC Peripheral Line Parameters Page 1 and ATUSP2 SDLC Peripheral Line Parameters Page 2 panels are within range and consistent with other related parameters. Changes that are either not in range or not consistent are highlighted in reverse-video pink and are recorded in the NetView log. No changes are sent to NCP with this key. Use F4 or F5 to send changes.

Important: You must verify any values you have changed on this panel before exiting this panel; otherwise, the changes are lost.

F3=RETURN

Returns to the previous NTuneMON panel.

F4=MODIFY,ACT or F4=DEACTIVATE

Available when the operator has tuning authority and NTuneNCP is included.

F4=MODIFY,ACT verifies and updates NCP tuning parameters with the modified values and activates the line. If the modification is not valid, the field turns reverse-video pink, and you are prompted to correct the value and resubmit the request. F4=DEACTIVATE uses the VTAM FORCE DEACTIVATION option to deactivate the line so that tuning changes can be made.

Important: See the description of F2=VERIFY before using this key.

F5=MODIFY

Available when the operator has tuning authority and NTuneNCP is included. For more information, refer to Chapter 5, Using the NTuneNCP Tuning Feature.

Updates the NCP tuning parameter with the modified value. If the modification is not valid, the field turns reverse-video pink, and you are prompted to correct the value and resubmit it.

Important: See the description of F2=VERIFY before using this key.

F6=ROLL

Returns to the NetView command line without exiting NTuneMON. To return to NTuneMON from the NetView program, press F6=ROLL or enter **ATUNEMON** on the NetView command line.

F8=FORWARD

Scrolls forward to the ATUSP2 SDLC Peripheral Line Parameters Page 2 panel, as shown on page 4-255.

ENTER=STATIONS(PUs)

Displays the ATUSL SDLC Stations List panel as shown on page 4-246.

F10=HEX

Displays the ATUDP Hexadecimal Storage Display panel, as shown on page 4-68, to show the line control block (LKB).

F11=LINE DETAILS

Displays the ATUPL SDLC Physical Line Details panel, as shown on page 4-217.

F12=REFRESH

Refreshes the information on this panel.

PA1=EXIT

Exits NTuneMON.

PA2=LOG

Saves the information on this panel to the NetView log.

ATUSP2 SDLC Peripheral Line Parameters Page 2 Panel

Basic fast-path commands: None

Tuning fields: ACTIVTO, ETRATIO, RNRLIMT, SRETRY, REDIAL, RETRIES, REPLYTO, RETRYTO, TEXTTO, XMITDLY, PAUSE, LSPRI, SERVLIM, HDXSP

```

ATUSP2  A71NT05                                     NTuneMON V2R1  07:32
SDLC Peripheral Line Parameters Page 2

Line A71LN36 Element Address 0022

Error Recovery Processing Parameters

ACTIVTO = 60.0          REPLYTO = 60.0
ETRATIO = 30           RETRYTO = N/A
RNRLIMT = 3           TEXTTO = 3.0
SRETRY = N/A          XMITDLY = N/A
REDIAL = ( 0 , 0 , 0 , 0 )
RETRIES = ( 5 , 255 , 20 )

Performance and Tuning Parameters

PAUSE = ( 1.0 , 2.8 )  LSPRI = PU  SERVLIM = 4  HDXSP = N/A

=>
F1=HELP F2=VERIFY F3=RTN F4=MODIFY,ACT F5=MODIFY F6=ROLL F7=BACK F9=MOD TIMER
ENTER=STATIONS(PUs) F10=HEX F11=LINE DETAILS F12=REFRESH PA1=EXIT PA2=LOG
    
```

Figure 6-24. ATUSP2 SDLC Peripheral Line Parameters Page 2 Panel

Description

The ATUSP1 SDLC Peripheral Line Parameters Page 1 panel, as shown on page 6-122, and the ATUSP2 SDLC Peripheral Line Parameters Page 2 panel can be used together to display and update information about various parameters for SDLC peripheral lines.

The ATUSP2 SDLC Peripheral Line Parameters Page 2 panel displays error recovery information and performance tuning parameters. Unlike the configuration parameters on the ATUSP1 SDLC Peripheral Line Parameters Page 1 panel, the parameters on this panel may need adjusting when the current values are not adequate.

To display this panel: From the ATUSP1 SDLC Peripheral Line Parameters Page 1 panel, as shown on page 4-249, press F8.

Notes:

1. F5=MODIFY updates NCP with all the current changes on both the ATUSP1 SDLC Peripheral Line Parameters Page 1 and ATUSP2 SDLC Peripheral Line Parameters Page 2 panels.
2. None of the parameters on this panel are modifiable unless the line is inactive.
3. If N/A is displayed in a panel field, the field is *not* shown in reverse-video turquoise and is *not* modifiable.

Tuning Fields

ACTIVTO (NCP V7R2 or later releases)

Specifies, in seconds, how long the secondary NCP is to wait for communication from the primary NCP before initiating shutdown. Defined by the ACTIVTO keyword on the GROUP statement.

NDF Default

60.0

Minimum

1.0

Maximum

420.0

Considerations

- The line must be inactive before this field can be modified.
- If there is more than one line in the group containing this line, ACTIVTO is not modifiable.

Tuning Suggestions

As a guide in determining the appropriate ACTIVTO value, choose a value such that the following expression is true:

$$(\text{maxout-ipl}) \geq \text{count} \geq (\text{t} \times \text{n}) \geq \text{sdo}$$

Where:

- *maxout* is the maximum time the controller can be out of service because of link failure.
- *ipl* is the interval normally required to load (IPL) the controller. Because this is a peripheral line, loading is not required and the value of *ipl* should be 0.
- *count* is the value of the ACTIVTO keyword.
- *sdo* is the average duration of short-duration outages.

ETRATIO (NCP V7R2 or later releases)

Specifies, in 10ths of a percent, the error-to-transmission ratio (the ratio of the number of errors to the number of transmissions), as defined by the ETRATIO keyword on the LINE statement. For example, ETRATIO=125 indicates an error-to-transmission ratio of 12.5%.

NDF Default

30

Minimum

1

Maximum

255

Considerations

- The line must be inactive before this field can be modified.
- If LPDATS=LPDA2 and CHNLZ=YES, ETRATIO does not apply.
- ETRATIO is used by programs that analyze statistical maintenance records, but not by NetView. ETRATIO does not affect the operation of NCP.

Tuning Suggestions

For accurate data, set ETRATIO meticulously.

RNRLIMIT (NCP V7R2 or later releases)

Specifies, in minutes, how long NCP is to allow a station to refuse to accept data before identifying the station as inoperative. Defined by the RNRLIMIT keyword on the GROUP statement. For example, a station is identified as inoperative if it responds with a receive-not-ready (RNR) command to every poll sent by NCP during the specified interval.

NDF Default

3

Minimum

1

Maximum

90

Considerations

- The line must be inactive before this field can be modified.
- If there is more than one line in the group containing this line, RNRLIMIT is *not* modifiable.

Tuning Suggestions

None

SRETRY (NCP V5R3 or later releases)

Number of retries to be attempted when a PU becomes secondary, as defined by the SRETRY keyword on the LINE statement.

NDF Default

15

Minimum

0

Maximum

128

Considerations

- The line must be inactive before this field can be modified.
- Applies only to switched lines.
- If DIAL=NO, SRETRY does *not* apply.

Tuning Suggestions

None

REDIAL(m, t1, n, t2)

Determines the timing and maximum number of dialing operations NCP performs in attempting to reach a device over a switched line, as defined by the REDIAL keyword on the LINE statement. NCP performs dialing operations in sequences, with a pause between dialing operations in each sequence and a pause between sequences.

Note: For SDLC lines, the number of dialing operations in each sequence, REDIAL (*m*), is provided by the access method.

REDIAL(*t1*) (NCP V4R3.1 or later releases)

Specifies, in seconds, the pause between dialing operations in each sequence, as defined by the *t1* suboperand of the REDIAL keyword on the LINE statement. You must specify a value that is a multiple of three.

NDF Default

0

Minimum

0

Maximum

765

REDIAL(*n*) (NCP V4R3.1 or later releases)

Determines the maximum number of dialing sequences, as defined by the *n* suboperand of the REDIAL keyword on the LINE statement.

NDF Default

0

Minimum

0

Maximum

255

Valid Values

Specify 255 for *n* to perform an unlimited number of sequences.

REDIAL(*t2*) (NCP V4R3.1 or later releases)

Specifies, in seconds, the pause between dialing sequences, as defined by the *t2* suboperand of the REDIAL keyword on the LINE statement.

NDF Default

0

Minimum

0

Maximum

765

Valid Values

Must be a multiple of 3

Considerations

- The line must be inactive before this field can be modified.
- If *n*=0, *t2* must=0.
- If DIAL=NO or X21NTWK=NO, REDIAL is *not* modifiable.
- If V25BIS=NO and LPDA2DL=NO and AUTO=NONE, REDIAL is not modifiable.

Tuning Suggestions

None

RETRIES(m, t, n)

Number of attempts to be made to recover from errors occurring during transmission over the link, as defined by the RETRIES keyword on the LINE statement. Each attempt at recovery, or *retry*, is a retransmission of data or control commands. NCP performs retries until the transmission is successful or the number of retries reaches the maximum specified by this keyword.

Retries are performed in sets, which are called *retry sequences*. NCP can perform one or more retry sequences. Successive retry sequences are separated by pauses. You can specify the number of retries in a sequence (*m*), the number of sequences to be performed, (*n*), and the length of the pause between sequences (*t*). The maximum number of retries NCP attempts equals $(m + 1) \times (n + 1) - 1$.

RETRIES(m) (NCP V4R3.1 or later releases)

Maximum number of retries in each retry sequence, as defined by the *m* suboperand of the RETRIES keyword on the LINE statement.

NDF Default

15

Minimum

0

Maximum

128

RETRIES(t) (starting with NCP V6R2)

Pause interval, in seconds, between successive retry sequences. Defined by the *t* suboperand of the RETRIES keyword on the LINE statement.

Note: The *t* on the LINE statement merely serves as a default value to be used for DR-added PUs for which VTAM does not provide NCP with a value for *t*. The *t* on the PU statement is the value that is actually used. See the ATUSD SDLC Station Details panel, as shown on page 6-113, for more information.

NDF Default

0

Minimum

0

Maximum

255

RETRIES(n) (starting with NCP V6R2)

Maximum number of retry sequences, as defined by the *n* suboperand of the RETRIES keyword on the LINE statement.

Note: The *n* on the LINE statement merely serves as a default value to be used for DR-added PUs for which VTAM does not provide NCP with a value for *n*. The *n* on the PU statement is the value that is actually used. See the ATUSD SDLC Station Details panel, as shown on page 6-113, for more information.

NDF Default

0 or 1

Minimum

0

Maximum

127

Considerations

- The line must be inactive before this field can be modified.
- *m* cannot be changed to zero. When *m* is already zero, you can change it to a non-zero number; however, *m* cannot then be changed back to zero.
- When $((n+1)*m) > 128$, the change is allowed, and *m* and *n* are highlighted in reverse-video pink.
- When *m*=0, then *t* and *n* must be zero.
- When MODE=SEC, then *t* and *n* are not modifiable because 0 is the only valid value. If the value for *m* is updated, the values for *t* and *n* for the stations on the line might also need updating, although it is not required.

Note: You can accomplish this task from the ATUSD SDLC Station Details panel, as shown on page 6-113.

Tuning Suggestions

None

REPLYTO (NCP V7R2 or later releases)

Note: This field is displayed in yellow when the timer value is modifiable or in dark blue when the timer value is not modifiable.

- Reply time-out value, in seconds, or values for the lines, as defined by the REPLYTO keyword on the GROUP statement. If NCP does not receive a response to a poll, selection, or message text before specified time expires, a time-out error is indicated and the appropriate error recovery procedure is started.
- For switched SDLC lines, NCP uses the interval specified by XMITDLY on this GROUP statement as the reply time-out value during initial XID exchange. In other cases, NCP uses the value of REPLYTO.

NDF Default

If you code LNCTL=SDLC, the default for REPLYTO is 1.0. However, if at least one station in the line group is defined as MODULO=128, the default is 3.0.

Minimum

0.0

Maximum

60.0

Other Valid Value

NONE – Timeouts do not occur regardless of the time that elapses between sending to the station and receiving a response.

Considerations

- The line must be inactive before this field can be modified.
- If there is more than one line in the group containing this line, REPLYTO is *not* modifiable.
- If REPLYTO is not equal to NONE and XMITDLY is not equal to NONE, REPLYTO must be \leq XMITDLY.
- If MODE=SEC, REPLYTO is not be modifiable because it has a fixed value that must *not* be changed.
- Consider link propagation delay, modem turnaround time, satellite switching delay, and device peculiarities.
- To choose a new value for REPLYTO, press F9 to display the ATUMT Modify Timer Value panel, as shown on page 4-189. See the ATUMT Modify Timer Value panel for details.

Attention: If you specify a value greater than 57.5 seconds, NCP might incorrectly report a scanner error.

Tuning Suggestion

The value for REPLYTO should be as small as possible for all multipoint links.

RETRYTO (NCP V7R2 or later releases)

Note: This field is displayed in yellow if the timer value is modifiable or in dark blue if the timer value is not modifiable.

Specifies, in seconds, how long NCP is to wait after receiving a retry call progress signal (CPS) before retrying a callout, as defined by the RETRYTO keyword on the GROUP statement.

NDF Default

3.0

Minimum

0.0

Maximum

1632.0

Considerations

- The line must be inactive before this field can be modified.
- If there is more than one line in the GROUP containing this line, RETRYTO is *not* modifiable.
- If X21SW=NO, RETRYTO does *not* apply.
- To choose a new value for REPLYTO, press F9 to display the ATUMT Modify Timer Value panel, as shown on page 4-189. See the ATUMT Modify Timer Value panel for details.

Tuning Suggestions

None

TEXTTO (NCP V7R2 or later releases)

Note: This field is displayed in yellow when the timer value is modifiable or in dark blue when the timer value is not modifiable.

Text time-out value, in seconds, for the line, as defined by the TEXTTO keyword on the GROUP statement.

NDF Default

3.0

Minimum

0.0

Maximum

1632.0

Other Valid Value

NONE – Timeouts do not occur regardless of the interval that elapses between receipt of successive sets of characters.

Considerations

- The line must be inactive before this field can be modified.
- If there is more than one line in this group containing this line, TEXTTO is *not* modifiable.
- If MODE=SEC, TEXTTO is *not* modifiable because it has a fixed value which must *not* be changed.
- For SDLC links, the recommended value is based on line speed.
- The value defined by TEXTTO is a nominal value. The actual elapsed time can be anything between the nominal value and twice the nominal value. For example, a nominal value of 30 seconds results in an actual interval of 30 to 60 seconds.
- To choose a new value for TEXTTO, and for more information, press F9 to display the ATUMT Modify Timer Value panel, as shown on page 4-189.

Attention: Diagnostic programs for the IBM 2845 and 2848 control units attached to lines within the group will fail if you define a value of more than 2 seconds for TEXTTO.

Tuning Suggestions

- Line speeds from 0 to 1199 bps need a time-out of about 4 seconds.
- Line speeds from 1200 to 2000 bps need a time-out of about 3 seconds.

XMITDLY (NCP V7R2 or later releases)

Note: This field is displayed in yellow when the timer value is modifiable or in dark blue when the timer value is not modifiable.

Reply time-out value used during initial XID exchange, as defined by the XMITDLY keyword on the GROUP statement.

NDF Default

Either 2.2 seconds or the value of REPLYTO, whichever is greater.

Minimum

The value of REPLYTO or 1.0 if REPLYTO=NONE.

Maximum

60.0

Other Valid Value

NONE – You do not want NCP to delay its initial transmission.

Considerations

- The line must be inactive before this field can be modified.
- If there is more than one line in the group containing this line, XMITDLY is *not* modifiable.
- If REPLYTO is not equal to NONE and XMITDLY is not equal to NONE, XMITDLY must be \geq REPLYTO.
- If DIAL=NO, XMITDLY does *not* apply.
- To choose a new value for XMITDLY, press F9 to display the ATUMT Modify Timer Value panel, as shown on page 4-189. See the ATUMT Modify Timer Value panel for details.

Tuning Suggestion

Consider modem equalization time.

PAUSE(t1, t2)

Delay in seconds between successive polling cycles, as defined by the PAUSE keyword on the LINE statement.

PAUSE(t1) (NCP V4R3.1 or later releases)

Pause, in seconds, for this line if the line is operating as a modulo-8 line. Defined by the *t1* suboperand of the PAUSE keyword on the LINE statement.

NDF Default

0.2

Minimum

0.0

Maximum

25.5

PAUSE(t2) (NCP V4R3.1 or later releases)

Pause, in seconds, for this line if the line is operating as a modulo-128 line. Defined by the *t2* suboperand of the PAUSE keyword on the LINE statement.

NDF Default

0.8

Minimum

0.0

Maximum

25.5

Considerations

- The line must be inactive before this field can be modified. In some cases PAUSE can be modified when the line is active from ATUPL

SDLC Physical Line Details panel. See the ATUPL SDLC Physical Line Details panel, as shown on page 6-102, for more information.

- If HDXSP=YES and ADDRESS=HALF, as defined on the LINE statement, *t1* or *t2* must be 0.
- Setting PAUSE to a very high value can cause performance and tuning problems.

Tuning Suggestions

- Decrease the PAUSE value if PIUs have a high traffic volume; increase the value when traffic volume is lower.
If traffic is restricted, set PAUSE= (average SOT Scan Time).
- Allowing a pause to elapse when activity on the link is relatively low can reduce the amount of processing time consumed by unproductive polling.
- You can improve performance of HPTSS lines by defining a pause of at least one second for a secondary NCP.
- Code different values for the primary and secondary NCPs.

LSPRI (NCP V4R3.1 or later releases)

Whether transmission priority is to be used to determine the order in which PIUs are transmitted to the PU, as defined by the LSPRI keyword on the LINE statement.

NDF Default

PU

Valid Values

- NO: Transmission is not to be used as the basis of transmission order. PIUs are transmitted in the order in which they are received.
- PU: The link outbound queue (LOBQ) is to be prioritized for each PU on the line. The priority of sessions across the PU is based on the transmission priority of virtual routes associated with these sessions.
- LINK: Replaces the SOT with a prioritized queue used for transmitting *all* PIUs across the link. The SOT is still used for polling.

LSPRI=LINK is valid for the following conditions:

- Peripheral links for which LNCTL=SDLC on the LINE statement
- T1 or T2 PUs on either duplex lines or half-duplex lines for which HDXSP=YES on the LINE statement

Considerations

- If LSPRI=LINK, performance might be degraded because this overrides PASSLIM.
- If HDXSP=NO and ADDRESS=HALF, as defined on the LINE definition statement, the value of LSPRI cannot be modified to LINK.
- The line must be inactive to modify LSPRI from this panel. In some cases, LSPRI can be modified when the line is active from the ATUPL SDLC Physical Line Details panel. See the ATUPL SDLC Physical Line Details panel as shown on page 4-217, for more information.

Tuning Suggestions

None

SERVLIM (NCP V4R3.1 or later releases)

Maximum number of regular scans of the service order table (SOT) that NCP is to make for normal servicing of PUs and LUs on the link before it makes a special scan of the SOT. Defined by the *entries* suboperand of the SERVLIM keyword on the LINE statement.

NDF Default

4

Minimum

1

Maximum

255

Considerations

- The line must be inactive before this field can be modified.
- If DIAL=NO and you specify MODE=SECONDARY on the GROUP statement, the SERVLIM scan limit is not valid.
- The SERVLIM scan limit is used mainly for primary multipoint links, but it can be modified for any SDLC line displayed by this panel.
- The modified value will be used when a new polling cycle is started.
- For multipoint lines, a high SERVLIM scan limit can cause long delays in the recovery or activation of the remote station.

Tuning Suggestions

Base your selection of a SERVLIM scan limit on:

- The relative number of status commands the access method issues for the link served by the SOT.
- The relative importance of the following alternatives:
 - A low SERVLIM scan limit gives NCP more frequent opportunities to fulfill accumulated status commands than does a higher value. Such status commands are fulfilled more promptly, but at the cost of frequent interruptions to normal servicing.
 - A higher SERVLIM scan limit causes fewer interruptions to normal servicing of devices but delays fulfillment of the status commands.
- Experience

You can minimize the possibility of throughput degradation by coding a high scan limit for SERVLIM or a low value for REPLYTO, or both.

HDXSP (NCP V4R3.1 or later releases)

Whether sending data to a terminal has priority over polling. This choice is defined by the HDXSP keyword on the LINE statement. HDXSP applies only to SDLC links that have one line interface address (half-duplex) and have more than one active device.

NDF Default

NO

Valid Values

- YES: Lets NCP send, at the first opportunity, outgoing data that is ready for transmission without having to wait until it is time to poll the destination terminal.
- NO: Lets NCP send the outgoing data when it is the destination terminal's turn to be polled. In this case, NCP sends the data just before sending the polling sequence unless the link is in the poll-wait state.

Considerations

- The line must be inactive before this field can be modified.
- HDXSP is valid only if you specified LNCTL=SDLC on the GROUP statement, PAUSE=0 on the LINE statement, and a single line interface in the ADDRESS keyword on the LINE statement.
- For lines with batch and interactive PU, HDXSP=YES can hurt response time.
- For lines with low utilization and many PUs, HDXSP=YES can help response time.

Tuning Suggestions

- Code HDXSP=NO in most cases.
- Code HDXSP=YES for interactive lines with low utilization and many PUs.

PF Keys

F1=HELP

Displays online help for this panel.

F2=VERIFY

Available when the operator has tuning authority and NTuneNCP is included.

Verifies that all the changes made on the ATUSP1 SDLC Peripheral Line Parameters Page 1 and ATUSP2 SDLC Peripheral Line Parameters Page 2 panels are within range and consistent with other related parameters. Changes that are either not in range or not consistent are highlighted in reverse-video pink and are recorded in the NetView log. No changes are sent to NCP with this key. Use F4 or F5 to send changes.

Important: You must verify any values you have changed on this panel before exiting this panel; otherwise, the changes are lost.

F3=RTN

Returns to the previous NTuneMON panel.

F4=MODIFY,ACT or F4=DEACTIVATE

Available when the operator has tuning authority and NTuneNCP is included.

F4=MODIFY,ACT verifies and updates NCP tuning parameters with the modified values and activates the line. If the modification is not valid, the field will turn reverse-video pink, and you will be prompted to correct the value and resubmit the request. F4=DEACTIVATE uses the VTAM FORCE DEACTIVATION option to deactivate the line so that tuning changes can be made.

Important: See the description of F2=VERIFY before using this key.

F5=MODIFY

Available when the operator has tuning authority and NTuneNCP is included.

Verifies and updates NCP tuning parameters with the modified values. If the modification is not valid, the field turns reverse-video pink, and you are prompted to correct the value and resubmit the request.

Important: See the description of F2=VERIFY before using this key.

F6=ROLL

Returns to the NetView command line without exiting NTuneMON. To return to NTuneMON from the NetView program, press F6=ROLL or enter **ATUNEMON** on the NetView command line.

F7=BACK

Scrolls back to the ATUSP1 SDLC Peripheral Line Parameters Page 1 panel, as shown on page 4-249.

F9=MOD TIMER

Displays the ATUMT Modify Timer Value panel, as shown on page 4-189, when the cursor is placed on one of the following keywords:

REPLYTO, RETRYTO, TEXTTO, XMITDLY.

To choose a new timer value for that keyword, use the ATUMT panel.

ENTER=STATIONS(PUs)

Displays the ATUSL SDLC Stations List panel as shown on page 4-246.

F10=HEX

Displays the ATUDP Hexadecimal Storage Display panel, as shown on page 4-68, to show the line control block (LKB).

F11=LINE DETAILS

Displays the ATUPL SDLC Physical Line Details panel, as shown on page 4-217.

F12=REFRESH

Refreshes the information on this panel.

PA1=EXIT

Exits NTuneMON.

PA2=LOG

Saves the information on this panel to the NetView log.

ATUST NCP Function Activation Panel

Basic fast-path commands: ST, SNAP, SNAPTRACE, POLL

Tuning fields: NTRI/FRAME RELAY SNAP TRACE ENABLED, ODLC SNAP TRACE ENABLED, HPR NLP ROUTE SNAP TRACE ENABLED, NPSI SNAP TRACE ENABLED, IP DATAGRAM SNAP TRACE ENABLED, IP ROUTE SNAP TRACE ENABLED, HPR ROUTE SETUP SNAP TRACE ENABLED, NTUNECOL

```

ATUST  A71SOX2  NCP FUNCTION ACTIVATION  NTuneMON V2R2  11:34

NTRI / FRAME-RELAY
SNAP TRACE  ENABLED = N/A
LAST ENTRY ADDR = N/A

ODLC SNAP TRACE  ENABLED = N/A
LAST ENTRY ADDR = N/A

HPR NLP ROUTE
SNAP TRACE  ENABLED = N/A
LAST ENTRY ADDR = N/A

NPSI
SNAP TRACE  ENABLED = YES
SNAP TRACE ADDR = 164494

IP DATAGRAM SNAP TRACE  ENABLED = N/A
LAST ENTRY ADDR = N/A

IP ROUTE SNAP TRACE  ENABLED = N/A
LAST ENTRY ADDR = N/A

HPR ROUTE SETUP
SNAP TRACE  ENABLED = N/A
LAST ENTRY ADDR = N/A

POLLING COUNT  NTUNECOL = NO

=>
F1=HELP  F3=RETURN          F6=ROLL  F10=HEX  F12=REFRESH  PA1=EXIT  PA2=LOG
    
```

Figure 6-25. ATUST NCP Function Activation Panel

Description

The ATUST NCP Function Activation panel is available for NCP V5R4 or later releases. It displays information about snap traces for NTRI, frame-relay, connectivity subsystem (CSS), NPSI, HPR resources, and IP resources.

This panel also displays the NTUNECOL keyword. This keyword indicates whether or not NCP is collecting NTuneMON-specific counters.

To display this panel:

- From the ATUSC4 3746 Model 900 Adapters panel, as shown on page 4-237, press F11.
- From the ATUTC Token-Ring Adapter List panel, as shown on page 4-278, press F11.
- From the ATUIS IP Router Statistics Page 1 panel, as shown on page 4-175, press F11.
- From the ATUIX IP Router Statistics Page 2 panel, as shown on page 4-180, press F11.

Tuning Fields

NTRI/FRAME RELAY SNAP TRACE ENABLED

(NCP V5R4 or later releases for NTRI; NCP V6R1 or later releases for frame relay)

Whether snap trace is enabled for NTRI and frame-relay resources, as defined by the NCPTRACE keyword on the BUILD statement. For more information about the snap trace for NTRI and frame-relay resources, see the *NCP, SSP, and EP Diagnosis Guide*.

NDF Default

NO

Valid Values

- YES: Snap trace is enabled.
- NO: Snap trace is not enabled.

Considerations

To enable this snap trace, Token-Ring or frame-relay resources must be defined in the generation. If they are not defined, this field displays N/A.

Tuning Suggestions

- Use the trace when you have an abend, an endless loop, or a performance problem related to NTRI or frame-relay resources.
- Because this trace might degrade NCP performance, use the trace at the request of your IBM support representative.

ODLC SNAP TRACE ENABLED (starting with NCP V6R2)

Whether snap trace is enabled for 3746 Model 900 resources. This snap trace provides diagnostic information for 3746 Model 900 resources by tracing the main 3746 Model 900 interface control blocks. This is a global trace for four types of interfaces: physical line, target processor, controller bus processor, and trace. For more information about the ODLC snap trace, see the *NCP, SSP, and EP Diagnosis Guide*.

NDF Default

NO

Valid Values

- YES: Snap trace is enabled.
- NO: Snap trace is not enabled.

Considerations

To enable this snap trace, a 3745 CSS adapter must be installed and defined in the generation. If ODLC resources are not defined, this field displays N/A.

Tuning Suggestions

None

HPR NLP ROUTE SNAP TRACE ENABLED (starting with NCP V7R4)

Whether snap trace is enabled for HPR NLP ROUTE, as defined by the HPRSNAP keyword on the BUILD statement. This snap trace provides information on NLPs routed through the NCP. For more information about the HPR NLP route snap trace, see the *NCP, SSP, and EP Diagnosis Guide*.

NDF Default

OFF

Valid Values

- YES: Snap trace is enabled.
- NO: Snap trace is not enabled.

Considerations

To enable this snap trace, HPR resources must be defined in the generation. If they are not defined, this field displays N/A.

Tuning Suggestions

Because this trace might degrade NCP performance, use the trace at the request of your IBM support representative.

NPSI SNAP TRACE ENABLED (NCP V7R2 or later releases)

Whether snap trace is enabled for NPSI X.25 resources, as defined by the X25SNAP keyword on the BUILD statement. This snap trace provides diagnostic information for NPSI X.25 resources by tracing the flow during execution of each module. For more information about the NPSI snap trace, see the *NCP Version 7 and X.25 NPSI Version 3 Diagnosis, Customization, and Tuning* manual.

NDF Default

Not included in the generation.

Valid Values

- YES: Snap trace is enabled.
- NO: Snap trace is not enabled.

Considerations

To enable this snap trace, NPSI resources using NPSI V3R7 or later must be installed in the NCP. If NPSI is not installed, this field displays N/A.

Tuning Suggestions

None

IP DATAGRAM SNAP TRACE ENABLED (starting with NCP V7R1)

Whether snap trace is enabled for IP resources, as defined by the datagram suboperand of the IPSNAP keyword on the BUILD statement. This snap trace provides diagnostic information for IP resources by tracing datagrams that are being discarded by NCP. For more information about the snap trace for IP resources, see the *NCP, SSP, and EP Diagnosis Guide*.

NDF Default

NO

Valid Values

- YES: Snap trace is enabled.
- NO: Snap trace is not enabled.

Considerations

To enable this snap trace, IP resources must be defined in the generation. If they are not defined, this field displays N/A.

Tuning Suggestions

Use this trace when NCP is discarding datagrams, but only at the request of your IBM support representative.

IP ROUTE SNAP TRACE ENABLED (starting with NCP V7R1)

Whether snap trace is enabled for IP routes, as defined by the route suboperand of the IPSNAP keyword on the BUILD statement. This snap trace provides diagnostic information for IP resources by tracing IP routing information. For more information about this snap trace, see the *NCP, SSP, and EP Diagnosis Guide*.

NDF Default

NO

Valid Values

- YES: Snap trace is enabled.
- NO: Snap trace is not enabled.

Considerations

To enable this snap trace, IP resources must be defined in the generation. If they are not defined, this field displays N/A.

Tuning Suggestions

Use the trace when there are problems with IP routing tables, but only at the request of your IBM support representative.

HPR ROUTE SETUP SNAP TRACE ENABLED (starting with NCP V7R4)

Whether snap trace is enabled for HPR route setup, as defined by the HPRSNAP keyword on the BUILD statement. This snap trace records the flow of HPR route activation and deactivation information going through the NCP. For more information on the HPR route setup snap trace, see the *NCP, SSP, and EP Diagnosis Guide*.

NDF Default

OFF

Valid Values

- YES: Snap trace is enabled.
- NO: Snap trace is not enabled.

Considerations

To enable this snap trace, HPR resources must be defined in the generation. If they are not defined, this field displays N/A.

Tuning Suggestions

Because this trace might degrade NCP performance, use the trace at the request of your IBM support representative.

POLLING COUNT NTUNECOL (NCP V7R2 or later releases)

Whether NCP is collecting information for NTuneMON, as defined by the NTUNECOL keyword on the BUILD statement. The information collected includes poll counts for inboard SDLC lines and stations and inboard channels.

NDF Default

NO

Valid Values

- YES: NCP collects information for NTuneMON.
- NO: NCP does not collect information for NTuneMON.

Note: If Network Performance Analyzer (NPA) is active in NCP, NTuneMON information is also collected even if NTUNECOL=NO.

Considerations

You cannot specify what kind of information is collected. NTUNECOL either collects all or none of the information. Enabling NTUNECOL degrades performance for sending and receiving data.

Tuning Suggestions

If NPA collection is not active, turn NTUNECOL on only when you actually need to see the information.

PF Keys

F1=HELP

Displays online help for this panel.

F3=RETURN

Returns to the previous NTuneMON panel.

F5=MODIFY

Available if the operator has tuning authority and if NTuneNCP is included. Starts or stops the requested NCP function.

F6=ROLL

Returns to the NetView command line without exiting NTuneMON. To return to NTuneMON from the NetView program, press F6=ROLL or enter **ATUNEMON** on the NetView command line.

F10=HEX

When the cursor is placed under a snap trace, displays the ATUDP Hexadecimal Storage Display panel, as shown on page 4-68, to show the control block associated with that snap trace. When nothing is selected, displays the ATUDP Hexadecimal Storage Display panel, to show a generic control block that has pointers to the specific control blocks associated with each snap trace.

F12=REFRESH

Refreshes the information on this panel.

PA1=EXIT

Exits NTuneMON.

PA2=LOG

Saves the information on this panel to the NetView log.

ATUTD NTRI Frame Handlers Logical Line Details Panel

Basic fast-path commands: None

Tuning fields: COMRATE, MAC Address, LMI

```

ATUTD A71NT06 NTRI Frame Handlers Logical Line Details NTuneMON V2R1 16:01
Route through 0 Bridges LLC Status: Link Opened

Elapsed Time
0
BDGLF = -
T1LOC = 1.5
T1REM = 2.5

-----
Line Name = A71FTLLN
PHYPORT = 1
COMRATE = 1
DATBLK = 2048
MAXFRAME = 8000
Max DLCI = 991
MAC Address = 400000041088

Local Management Interface DLCI 0
LMI = ANSI PU Status = ACTIVE
Network and User Side
LVL3 Discards = 0
LVL5 Discards = 0
User Network
N391 = 6 N392 = 3/0
N392 = 3/0 N393 = 4
N393 = 4 N393 = 4
T391 = 10 Sec T392 = 15 Sec
Send = 16(10) Send = 16(10)
Rcvd = 16(10) Rcvd = 17(11)

-----
Frame Statistics
Max Size Frame Sent = 1025
Min Size Frame Sent = 25
Number of Frames Sent = 832
Estimated Bytes Sent = -
=> ATUM017 Press F12 to see Traffic or Polling rates
F1=HELP F3=RETURN F4=RESET MIN/MAX F5=MODIFY F6=ROLL F10=HEX
ENTER=DLCIs F12=REFRESH/TRAFFIC RATES PA1=EXIT PA2=LOG
    
```

Figure 6-26. ATUTD NTRI Frame Handlers Logical Line Details Panel

Description

The ATUTD NTRI Frame Handlers Logical Line Details panel, which is available for NCP V7R3 or later releases, displays detailed information on a NTRI frame handler logical line associated with a type 1 or type 2 TIC.

To display this panel:

- On the ATUTF NTRI Frame Handler Logical Lines panel, as shown on page 4-291, place the cursor under a line and press Enter.
- On the ATUFS1 Frame Relay Switching Equipment Page 1 panel, as shown on page 4-127, place the cursor under the LINE ADDR field of a NTRI frame handler logical line and press Enter.

Tuning Fields

COMRATE

Relative transmit priority for this line as defined by the *priority* suboperand of the COMRATE keyword on the LINE statement.

NDF Default

1

Minimum

1

Maximum

64

Considerations

The value of the *priority* suboperand is multiplied by the value of the DATABLK keyword on the LINE statement to determine the guaranteed minimum number of bytes that a resource can transmit before a different resource must be given a transmission opportunity.

Tuning Suggestions

Unless you anticipate high volumes for a line, you should specify similar rates for all associated frame handler logical units.

MAC Address (modifiable starting with NCP V7R5)

MAC address of the destination TIC where the line terminates. The last 6 bytes specified for the ADDR keyword on the PU statement are the destination MAC address for the logical line.

NDF Default

None

Minimum

X'0000 0000 0001'

Maximum

X'7FFF FFFF FFFF'

Considerations

The physical line must be inactive before this field can be modified.

Tuning Suggestions

Use this tuning field to correct an error in the destination MAC address value, which is specified in the ADDR keyword, without regenerating your NCP.

LMI (CCITT|CCITT-NUI|ANSI|ANSI-NUI|NO) (-NUI option available starting with NCP V7R6)

LMI standard, as defined by the LMI keyword on the PU statement.

NDF Default

CCITT

Valid Values

- CCITT: Q.933 Annex A (the international LMI standard), with the interface (UNI, NNI, or NUI) determined by NCP.
- CCITT-NUI: Q.933 Annex A (the international LMI standard), with the Network-to-User interface.
- ANSI: ANSI T1.617 Annex D (the U.S. LMI standard), with the interface (UNI, NNI, or NUI) determined by NCP.
- ANSI-NUI: ANSI T1.617 Annex D (the U.S. LMI standard), with the Network-to-User interface.
- NO: The adjacent subport does not support LMI protocol.

Considerations

- Cannot be changed if NO is displayed instead of an LMI standard.
- Cannot be changed from an LMI standard to NO.
- The LMI PU must be inactive before this field can be changed.

ATUTD NTRI Frame Handlers Logical Line Details Panel

- Can be changed if the maximum DLCI address of the current standard is an acceptable size for the standard to which you want to switch. To determine if the standard can be changed, do the following computation:

$$((maxframe - fixed)/5) + 15$$

Where:

maxframe is the value displayed for Maxframe on this panel.

fixed is 17 if you want to switch to CCITT or 18 if you want to switch to ANSI.

If the value of your computation is equal to or greater than the value displayed for Max DLCI on this panel, you can switch the standard.

However, if your computation is greater than the value of Max DLCI, the NCP may be supporting fewer DLCIs than if it had been generated with the standard to which you are switching.

Tuning Suggestions

- The LMI protocol, which provides information on the PVC status and link integrity, should only be changed to prevent an LMI mismatch. Change CCITT to ANSI if you want to switch from the Q.933 Annex A international standard to the T1.617 Annex D U.S. standard. Change ANSI to CCITT if you want to switch from the T1.617 Annex D U.S. standard to the Q.933 Annex A international standard.
- The -NUI option is for shortening connect time when the adjacent device supports only a User-to-Network connection. It tells NCP to activate immediately, using the Network-to-User interface, without determining the interface type.

PF Keys

F1=HELP

Displays online help for this panel.

F3=RETURN

Returns to the previous NTuneMON panel.

F4=RESET MIN/MAX

Available when the operator has tuning authority and NTuneNCP is included. For more information, refer to Chapter 5, Using the NTuneNCP Tuning Feature.

Resets the values of the Max Size Frame Sent and Min Size Frame Sent fields. After resetting the fields, NTuneMON automatically refreshes the panel. If new traffic rates are available, they are displayed. Otherwise, NTuneMON displays a dash (–) until new traffic rates are available and you press F12 or reenter the panel to display the new rates.

F5=MODIFY

Available when the operator has tuning authority and if NTuneNCP is included. For more information, refer to Chapter 5, Using the NTuneNCP Tuning Feature.

Updates the NCP tuning parameter with the modified value. If the modification is not valid, the field turns reverse-video pink, and you are prompted to correct the value and resubmit it.

F6=ROLL

Returns to the NetView command line without exiting NTuneMON. To return to NTuneMON from the NetView program, press F6=ROLL or enter **ATUNEMON** on the NetView command line.

F10=HEX

Displays the ATUDP Hexadecimal Storage Display panel, as shown on page 4-68, to show the logical link control block (LLB) for this line.

ENTER=DLCIs

Displays the ATUFA Frame Relay Support List panel, as shown on page 4-88, to show all the FHSPs for this line.

F12=REFRESH/TRAFFIC RATES

Refreshes the information on this panel and displays the traffic rates.

PA1=EXIT

Exits NTuneMON.

PA2=LOG

Saves the information on this panel to the NetView log.

ATUTL Token-Ring SNA Station Panel

Basic fast-path commands: None

Tuning fields: T1LOC, T1REM, T2LOC, T2REM, N3GEN, CONGESTION, STATION, #PIUS/BLOCK, DYNWIND(NW,DW,DWC), SSAP, T/R Address, UNIQUE, DSAP, MAXDATA GEN, MAXOUT GEN, BLOCK GEN, PIUCHECK GEN

```

ATUTL A12V7R8 Token-Ring SNA Station A71V7RX NTuneMON V2R6 10:21
Route through 1 Bridges LLC Status: Link Opened BDGLF = 17800
                                         T1LOC = 2.0
                                         T1REM = 5.0
                                         T2LOC = 0.0
                                         T2REM = 0.0
                                         N3GEN = 2
                                         #PIUS/BLOCK = 0
                                         DYNWIND(NW,DW,DWC) = 4 1 0
                                         DESTINATION STATION Subarea Station
                                         IDBLK-IDNUM= - LINE= A12LL89Y
                                         T/R Address= 400000711089 DSAP = 10
                                         UNIQUE = NO
                                         CPNAME = - ACTIVE
                                         TG= 1 SUBAREA= 71 NETID= NETA

FF1 - FF3
  2
CONGESTION = NONE STATION = NORMAL
MODE = NORMAL
NCP TOKEN-RING TIC
Line Addr= 1089 TIC2 16M
T/R Addr = 400000121089
SSAP = 10
PHYPORT = 89 ACTIVE

FRAME STATISTICS: TRANSMIT RECEIVE CUR: GEN:
MAXTSL/RCVBUFC = 4096 <----> 8192 MAXDATA = 4096 0
Frames Count = 0001 --><-- 0001 MAXOUT = 8 8
WW / Outs. Frame ct = 8/- BLOCK = 0 0
N3 / I-Frame Rcv ct = 1/0 PIUCHECK = NO NO

=>
F1=HELP F2=DISG STATION PU F3=RETURN F4=Force Reroute F5=MODIFY F6=ROLL
ENTER-TG DETAILS(SUBA ONLY) F10=HEX F12=REFRESH PA1=EXIT PA2=LOG
    
```

Figure 6-27. ATUTL Token-Ring SNA Station Panel

Description

The ATUTL Token-Ring SNA Station panel, which is available for NCP V5R4 or later releases, displays detailed information on a specific Token-Ring logical SNA station. All Token-Ring SNA logical peripheral stations are switched, whereas all Token-Ring logical subarea stations are leased. Also, there is a one-to-one correspondence of logical line to logical station.

To display this panel: On the ATUTA Token-Ring SNA Station List panel, as shown on page 4-273, place the cursor under a station and press Enter. See the description of that panel for more information.

Tuning Fields

Notes:

1. The values in the GEN fields are either the values from the NCP generation or the values resulting from subsequent NCP processing that overwrote the values from the NCP generation.
2. The values in the CUR fields are working values that are either set or limited by the corresponding GEN fields.

T1LOC

Token-Ring reply timer (T1) value for stations connected to a local Token Ring as defined by the LOCALTO keyword on the LINE statement or the *localt1* suboperand of the T1TIMER keyword on the LINE statement.

NDF Default

The value of the REMOTTO keyword or the *remott1* suboperand of the T1TIMER keyword on this LINE statement or the value of the LOCALTO keyword or the *localt1* suboperand of the T1TIMER keyword on the BUILD statement, whichever is less.

Minimum

0.6

Maximum

20.0

Considerations

- Can be modified only for subarea stations.
- The station must be inactive before this field can be modified.
- T1LOC must be less than or equal to T1REM. Refer to “Implementing Tuning Changes” on page 5-15 for additional information.

Tuning Suggestions

Values used for the reply timer by NCP and the adjacent link station should be similar. Using values that differ by a factor of 5 or more can result in performance problems and unnecessary station INOP requests.

T1REM

Token-Ring reply timer (T1) value for stations connected to a remote Token Ring as defined by the REMOTTO keyword on the LINE statement or the *remott1* suboperand of the T1TIMER keyword on the LINE statement.

NDF Default

The value of the REMOTTO keyword or the *remott1* suboperand of the T1TIMER keyword on the BUILD statement, or, if not coded on the BUILD statement, the value 2.5.

Minimum

0.6

Maximum

20.0

Considerations

- Can be modified only for subarea stations.
- The station must be inactive before this field can be modified.
- T1LOC must be less than or equal to T1REM. Refer to Table 5-1 on page 5-7 for additional information.

Tuning Suggestions

Values used for the reply timer by NCP and the adjacent link station should be similar. Using values that differ by a factor of 5 or more can result in performance problems and unnecessary station INOP requests.

T2LOC

Timer value used for connections over a local Token Ring as defined by the *localt2* suboperand of the T2TIMER keyword on the LINE statement.

NDF Default

The value coded for the *localt2* suboperand of the T2TIMER keyword on the BUILD statement.

Minimum

0.0 – This value indicates that the timer is not to be used for this line.

Maximum

2.0

Considerations

- Can be modified only for subarea stations.
- The station must be inactive before this field can be modified.
- Decreasing T2LOC limits the number of retransmissions because of a line error.
- Increasing T2LOC potentially increases the number of retransmissions due to line error.

Tuning Suggestions

The local acknowledgement timer value should be approximately one-tenth the value specified for the reply timer for the adjacent station. This ensures that the adjacent station receives the acknowledgement before its reply timer expires.

T2REM

Timer value used for connections over a remote Token Ring as defined by the *remott2* suboperand of the T2TIMER keyword on the LINE statement.

NDF Default

The value coded for the *remott2* suboperand of the T2TIMER keyword on the BUILD statement.

Minimum

0.0 – This value indicates that the timer is not to be used for this line.

Maximum

2.0

Considerations

- Can be modified only for subarea stations.
- The station must be inactive before this field can be modified.
- Decreasing the T2TIMER value limits the number of retransmissions because of a line error.
- Increasing the T2TIMER value potentially increases the number of retransmissions due to line error.

Tuning Suggestions

The remote acknowledgement timer value should be approximately one-tenth the value specified for the reply timer for the adjacent station. This ensures that the adjacent station receives the acknowledgement before its reply timer expires.

N3GEN

Maximum number of I-frames that NCP can receive without sending an acknowledgement. Defined by the *n3* suboperand on T2TIMER on the LINE statement.

NDF Default

The value coded for *n3* on the T2TIMER keyword on the BUILD statement.

Minimum

1

Maximum

127

Considerations

- The field can be modified for subarea stations only.
- The station must be inactive before this field can be modified.

Tuning Suggestions

The acknowledgement window size should be less than the value of MAXOUT specified by the other NCP or other device.

CONGESTION (starting with NCP V7R6)

The station's role in congestion relief as defined by the third parameter of the TGCONF keyword on the PU definition statement:

- If the station can be used to relieve congestion, this field displays the station's threshold percentage.
- If the station can be used as a standby station but not to relieve congestion, this field displays NONE.
- If the station cannot be used as a standby station, this field displays N/A.

NDF Default

NONE

Valid Values

- 3, 6, 12, 25, 50, 75, 87, 93, 97, or 100: Defines the congestion threshold as a percentage of the *totthresh* parameter coded on the ERn keyword on the associated PATH statement. When this congestion threshold is exceeded, the standby station will help transmit data until the congestion is relieved.
- NONE: The station will not be used to relieve congestion. NONE is required when the STATION field displays NORMAL or when SINGLE was coded as the first parameter of the TGCONF keyword on the PU statement.

Considerations

- This field applies only to a transmission group subarea link station that has been designated as hot-standby station (TGCONF=STANDBY).
- The station must be inactive before this field can be modified.
- The standby station can transmit data when this congestion threshold is exceeded.

Tuning Suggestions

None.

STATION (starting with NCP V7R6)

Whether the station can be used for hot standby (STANDBY) or cannot (NORMAL), as defined by the TGCONF keyword on the PU definition statement.

NDF Default

NORMAL

Valid Values

- NORMAL: The station can transmit data anytime data is queued for transmission.
- STANDBY: The station is reserved for use as a hot-standby station. STANDBY is not valid if no TGCONF keyword or TGCONF=SINGLE was coded on the PU definition statement.

Considerations

- This field applies only to a transmission group subarea link station.
- The station must be inactive before this field can be modified.

Tuning Suggestions

None.

#PIUs/BLOCK (starting with NCP V6R2)

Maximum number of PIUs for multiple-PIU frames as defined by the *pius* suboperand of the BLOCK keyword on the PU statement.

NDF Default

0 if the value of *bytes* (BLOCK) is 0; otherwise, the default is 8.

Minimum

0 if the value of *bytes* (BLOCK) is 0; otherwise, the minimum is 2.

Maximum

16

Considerations

- Can be modified only for subarea stations.
- If BLOCK is not 0, then #PIUs/block must be greater than 0.

Tuning Suggestions

To reduce the number of interframe gaps, set both BLOCK and #PIUs/BLOCK as high as possible.

DYNWIND(NW,DW,DWC)

Values used by NCP to modify the IEEE 802.2 LLC working window parameter.

DYNWIND(NW) (starting with NCP V7R1)

Number of frames that must be received and acknowledged by the adjacent device before the sending NCP increases the IEEE 802.2 LLC working window value. When the sending NCP receives acknowledgements for *nw* consecutive I-frames, the working window value is

increased until it reaches the value specified by MAXOUT for subarea connections, or the value specified in the VTAM switched major node for peripheral connections.

For a physical Token-Ring line, for NCP V7R1 through V7R4, the value in this field is defined by the *nw* suboperand of the DYNWIND keyword on the GROUP or LINE statement. For NCP V7R1 and V7R2, the value applies to all logical lines and stations associated with that physical line.

For a logical subarea Token-Ring station, for NCP V7R3 or later releases, the value in this field is defined by the *nw* suboperand of the DYNWIND keyword on the GROUP, LINE, or PU statement. For a peripheral station, for NCP V7R3 and later releases, the value is defined in the VTAM switched major node. Or if it is not defined in VTAM, the value is defined on the physical station's GROUP or LINE statement. Beginning with NCP V7R5, DYNWIND(*nw*) is also allowed on the PU statement for the physical station.

NDF Default

4

Minimum

1

Maximum

8

Considerations

- Not modifiable for type 3 TIC.
- For type 1 or type 2 TIC, *nw* associated with this logical line is modifiable if the following conditions are true:
 - The logical link is open.
 - The logical station is active.
 - For logical peripheral stations, the logical line must be associated with the same physical line as when this panel was displayed. For example, if the logical line has gone down and the line's control blocks have been reused for a different line, the modification is not allowed.

Notes:

1. For NCP V7R1 and V7R2, the change applies only to this logical line and remains in effect only for as long as the logical line is active. To make permanent changes for all logical lines on the physical line, use the ATUTP1 Token-Ring TIC Details Page 1 panel, as shown on page 6-170.
2. For NCP V7R3 or later releases, if this is a logical subarea station, the change is permanent. If this is a logical peripheral station, the change remains in effect only for as long as the station is active. To make permanent changes, change the definition in the VTAM switched major node, if the value is defined in the switched major node; otherwise, make the change to the physical line using the ATUTP1 Token-Ring TIC Details Page 1 panel, as shown on page 6-170.

Tuning Suggestions

In most cases, the default value is the best choice. However, in a Token-Ring network where congestion is frequent or long-lasting (for example, longer than 30 seconds), increase DYNWIND(nw) to help alleviate congestion. This slows the transmission rate of affected stations for a longer time to give the network more time to recover. In a Token-Ring network where congestion is infrequent or lasts for a very short time, decrease DYNWIND(nw) to help the NCP recover more quickly.

DYNWIND(DW) (starting with NCP V7R8; TIC1 and TIC2 resources only)

Value by which the sending NCP divides, or percentage by which the sending NCP reduces, the IEEE 802.2 LLC working window value when frame loss occurs.

The value in this field is defined by the *dw* suboperand of the DYNWIND keyword on the GROUP, LINE, or PU statement for a logical subarea Token-Ring station. For a peripheral station, the value is defined in the VTAM switched major node, or if not defined in VTAM, on the GROUP, LINE, or PU statement for the Token-Ring physical station.

NDF Default

1

Valid Values

1, 2, 4, 6, 8, 12, 16, 25, 50, 75, 87, 93

Considerations

- 1 is a special value which indicates that the working window value should be set to 1 when frame loss is detected.
- Not modifiable for 3746 Model 900 lines.
- For 3745 lines, the *dw* associated with this logical line is modifiable if the following conditions are true:
 - The logical line is open.
 - The logical station is active.
 - For logical peripheral stations, the logical line is associated with the same physical line as when this panel was displayed. For example, if the logical line has gone down and the line's control blocks have been reused for a different line, the modification is not allowed.

Notes:

1. For logical subarea stations, the change is permanent.
2. For logical peripheral stations, the change remains in effect only for as long as the station is active. To make a permanent change, change the definition in the VTAM switched major node if the parameter is defined in the switched major node; otherwise make the change to the physical line using the ATUTP1 Token-Ring TIC Details Page 1 panel, as shown on page 6-170.

Tuning Suggestions

In most cases, the default value is the best choice.

If possible, you should first tune DYNWIND(DWC) to try to alleviate congestion. The loss of frames (DW) is a more severe condition than the congestion indicated by receiving RNR (DWC). Mistuning

DYNWIND(DW) might have a greater effect on throughput than mistuning DYNWIND(DWC).

However, where congestion is frequent or long-lasting (for example, longer than 30 seconds), you might want to increase DYNWIND(DW) to help alleviate congestion. This slows the transmission rate of affected stations for a longer time to give the network more time to recover. Where congestion is infrequent or lasts for a very short time, decrease DYNWIND(DW) to help the NCP recover more quickly.

DYNWIND(DWC) (starting with NCP V7R8; TIC1, TIC2 resources only)

Value by which the sending NCP divides, or percentage by which the sending NCP reduces, the IEEE 802.2 LLC working window value when congestion is assumed. Congestion is assumed from the time an RNR frame is received until the time an RR frame is received. The working window is reduced only once for each period of congestion.

The value in this field is defined by the *dwc* suboperand of the DYNWIND keyword on the GROUP, LINE, or PU statement for a logical subarea Token-Ring station. For a peripheral station, the value is defined in the VTAM switched major node, or if not defined in VTAM, on the GROUP, LINE, or PU statement for the physical Token-Ring station.

NDF Default

0

Valid Values

0, 1, 2, 4, 6, 8, 12, 16, 25, 50, 75, 87, 93

Considerations

- 0 is a special value, and is the default, to indicate that NCP will not reduce the working window during congestion.
- 1 is a special value which indicates that the working window value should be set to 1 during congestion.
- Not modifiable for 3746 Model 900 lines.
- For 3745 lines, *dwc* associated with this logical line is modifiable if the following conditions are true:
 - The logical line is open.
 - The logical station is active.
 - For logical peripheral stations, the logical line is associated with the same physical line as when this panel was displayed. For example, if the logical line has gone down and the line's control blocks have been reused for a different line, the modification is not allowed.

Notes:

1. For logical subarea stations, the change is permanent.
2. For logical peripheral stations, the change remains in effect only for as long as the station is active. To make permanent changes, change the definition in the VTAM switched major node if the parameter is defined in the switched major node; otherwise make the change to the physical line using the ATUTP1 Token-Ring TIC Details Page 1 panel, as shown on page 6-170.

Tuning Suggestions

In most cases, the default value is the best choice. However, when congestion is frequent or long-lasting (for example, longer than 30 seconds), increase DYNWIND(DWC) to help alleviate congestion. This slows the transmission rate of affected stations for a longer time to give the network more time to recover. When congestion is infrequent or lasts for a very short time, decrease DYNWIND(DWC) to help the NCP recover more quickly.

SSAP (starting with NCP V7R5)

Source service access point to use for the connection. Defined by the SSAP keyword on the PU statement for a Token-Ring logical subarea connection.

NDF Default

X'04'

Minimum

X'04'

Maximum

X'9C'

Considerations

- Can be modified only for subarea stations.
- The physical line must be inactive before this field can be modified.
- Must be a multiple of 4.

Tuning Suggestions

Use this tuning field to correct an error in the SSAP keyword without regenerating your NCP.

T/R Address (modifiable starting with NCP V7R5)

MAC address of the destination station. The last 6 bytes specified for the ADDR keyword on the PU statement are the destination MAC address for the subarea connection.

NDF Default

None

Minimum

X'0000 0000 0001'

Maximum

X'7FFF FFFF FFFF'

Considerations

- Can be modified only for subarea stations.
- The physical line must be inactive before this field can be modified.

Tuning Suggestions

Use this tuning field to correct an error in the destination MAC address value, which is specified in the ADDR keyword, without regenerating your NCP.

UNIQUE (starting with NCP V7R6)

Whether the destination MAC address, as defined by the ADDR keyword on the PU statement for a Token-Ring logical subarea connection, is a unique

locally administered address (YES) or a duplicate locally administered address (NO).

NDF Default

YES

Valid Values

- YES: This will prompt a test frame with a zero DSAP value to be sent during route discovery processing.
- NO: This will prompt a test frame with the DSAP value from the ADDR keyword to be sent during route discovery processing.

Considerations

The Token-Ring logical subarea line must be inactive before this field can be modified.

Tuning Suggestions

Change this field only if you have changed the Token-Ring logical subarea's destination MAC address and thus altered the destination address' uniqueness.

DSAP (formerly SAP; modifiable starting with NCP V7R5)

Destination service access point, part of the address field of LLC frames. The first byte specified for the ADDR keyword on the PU statement is the DSAP for the subarea connection.

NDF Default

None

Minimum

X'04'

Maximum

X'FC'

Considerations

- Can be modified only for subarea stations.
- The physical line must be inactive before this field can be modified.
- Must be a multiple of 4.

Tuning Suggestions

Use this tuning field to correct an error in the DSAP value, which is specified in the ADDR keyword, without regenerating your NCP.

MAXDATA GEN (starting with NCP V6R2)

Generated maximum inbound data³ size for the destination station. GEN is either the value from the NCP generation (MAXDATA keyword on the PU statement) or the value resulting from subsequent NCP processing that overwrote the generated value.

NDF Default

For a subarea station: If not coded, MAXDATA is not considered when determining segment size on an MLTG.

³ The data size does not include any header information.

Minimum

For a subarea station: 26 + (value of BFRS keyword on the BUILD statement)

Maximum

65535

Considerations

- Can be modified only for subarea stations and only if MAXDATA is a value other than 0 or dash (-).
- Only the generated value can be modified.
- The station must be inactive before this field can be modified.
- If MAXDATA is not specified, NCP does not take MAXDATA into consideration when calculating segment size for a multilink transmission group. Refer to the discussion of multilink transmission groups in *NCP, SSP, and EP Resource Definition Guide* for more information on using MAXDATA to coordinate segment size for different line control protocols in a multilink transmission group.

Tuning Suggestions

- Should be set to the smallest segment size used by any link in the MLTG, thereby eliminating transmission problems due to incompatible segment sizes for different links in the MLTG.
- Should be as large as possible for a device, to minimize segmentation.
- Should be a multiple of the BFRS keyword on the BUILD statement, to optimize the transmitted frame size to a minimum number of segmented frames because NCP will segment PIUs into multiples of NCP buffers. In addition, consider the 26 bytes required for the TH.

MAXOUT GEN

Generated maximum number of frames that NCP can send to the destination station before requiring an acknowledgement. GEN is either the value from the NCP generation (MAXOUT keyword on the PU statement) or the value resulting from subsequent NCP processing that overwrote the generated value.

NDF Default

8

Token-Ring TESP logical stations operate as if attached to a modulo-128 line.

Minimum

1

Token-Ring TESP logical stations operate as if attached to a modulo-128 line.

Maximum

127

Token-Ring TESP logical stations operate as if attached to a modulo-128 line.

Considerations

- Can be modified only for a subarea station.
- Only the generated value can be modified.
- The station must be inactive before this field can be modified.

- Specify a MAXOUT value that can be supported by the physical device.
- Not modifiable for switched stations.

Tuning Suggestions

- If retransmissions exist and MAXOUT is high, lower MAXOUT.
- A high MAXOUT can reduce the number of acknowledgements and time spent waiting for acknowledgements, but might increase the number of PIUs that must be retransmitted in a retry sequence.
- In a remote LAN environment, where the connection is across a wide-area network, consider the following issues:
 - MAXOUT needs to be high enough for NCP to transmit frames steadily to the wide-area network without introducing needless waiting for frequent acknowledgements.
 - If MAXOUT is too high, the remote bridge will suffer congestion from a single NCP monopolizing its transmission resources.

BLOCK GEN (starting with NCP V6R2)

Generated maximum multiple-PIU frame size. GEN is either the value from the NCP generation (*bytes* suboperand of the BLOCK keyword on the PU statement) or the value resulting from subsequent NCP processing that overwrote the generated value.

NDF Default

0

Minimum

0

Maximum

8192 if MAXDATA is 0; otherwise, this value must be less than or equal to the value of MAXDATA on the PU statement or 8192, whichever is smaller.

Considerations

- Can be modified only for subarea stations.
- Only the generated value can be modified.
- The station must be inactive before this field can be modified.
- If BLOCK is not 0, then #PIUs/block must be greater than 0.

Tuning Suggestions

- To reduce the number of interframe gaps, set the values, both BLOCK and #PIUs/BLOCK, as high as possible.
- To prevent multiple-PIU frames from being built, set BLOCK to 0.

PIUCHECK GEN (starting with NCP V7R7; subarea stations only)

Generated YES or NO value indicating whether a checksum validation is performed on PIUs sent from and received by this station. Unless tuned, this field is the value from the NCP generation (PIUCHECK keyword on the PU statement).

NDF Default

NO

Considerations

- The station must be inactive before you can modify this value.
- For the checksum validation support to be enabled, the adjacent link station must also have PIUCHECK=YES.

Tuning Suggestions

The PIUCHECK support increases the path length required for NCP to send or receive a PIU, so the PIUCHECK support should be used only when the additional protection is required.

PF Keys

F1=HELP

Displays online help for this panel.

F2=DISG STATION PU

Displays a graphic representation of the station (DISG CLIST). This display is useful for viewing the VTAM switched major node for peripheral stations. For this display, NTuneNCP must be running on the VTAM host that owns the line.

F3=RETURN

Returns to the previous NTuneMON panel.

F4=Force Reroute (starting with NCP V7R7)

Available when:

- The operator has tuning authority.
- NTuneNCP is included.
- The NTRI logical subarea connection is a bridged connection.
- The link station is active.
- The link is open.
- Nondisruptive route switching (NDRS) has not already been initiated for this subarea connection.

Requests that NCP initiate NDRS to locate another possible bridged route for the associated NTRI subarea connection. NCP will notify you of its progress, and if the rerouting is successful, you will be able to refresh the panel and see the new route. See messages ATUM711 and ATUM712 on page 9-11 for more information.

F5=MODIFY

Available when the operator has tuning authority and NTuneNCP is included. For more information, refer to Chapter 5, Using the NTuneNCP Tuning Feature.

Updates the NCP tuning parameter with the modified value. If the modification is not valid, the field turns reverse-video pink, and you are prompted to correct the value and resubmit it.

F6=ROLL

Returns to the NetView command line without exiting NTuneMON. To return to NTuneMON from the NetView program, press F6=ROLL or enter **ATUNEMON** on the NetView command line.

F10=HEX

Displays the ATUDP Hexadecimal Storage Display panel, as shown on page 4-68, to show the logical link control block (LLB) for a type 1 or type 2 TIC, or the Token-Ring logical station block extension (TSB) for a type 3 TIC.

ENTER=TG DETAILS (SUBAREA ONLY)

Displays the ATUML Multi-Link Transmission Group panel, as shown on page 6-93, for more information about the transmission group and the origin and destination NCPs.

F12=REFRESH

Refreshes the information on this panel.

PA1=EXIT

Exits NTuneMON.

PA2=LOG

Saves the information on this panel to the NetView log.

ATUTP1 Token-Ring TIC Details Page 1 Panel

Basic fast-path commands: None

Tuning fields: T/R LOCADD, TITIMER, DYNWIND(nw), DYNWIND(dw), DYNWIND(dwc), Conn Bal Fact

```

ATUTP1 A27GENC Token-Ring TIC Details Page 1 NTuneMON V2R6 13:42
OWNERPL Function Active = NO Elapsed Time = 0
Default View= MAC Dual= Status= ACTIVE TIC= 1092 Find=

NCP ADAPTER ATTACHMENT
Line Address= 1092 TIC2 16M
T/R LOCADD = 400000000001
Port Address= 1 ECL= BNN
Active Lines= 0
Reserved Lines= 250 0% Active
SNA PASSLIM = N/A
IP PASSLIM = N/A

LAST BEACONING INFORMATION
NO BEACONING --X-- N/A
Time: N/A Date: N/A

Token-Ring Adapter Status
INACTIVE

FRAME INFORMATION
MAXTSL Maximum Transmit PIU Size = 16732
RCVBUFC Maximum Receive Frame Size = 1440
DATABLK Data Block Size = 2048
MAXFRAME Maximum Frame Size = N/A
Receive Congestion Counter = 0

TITIMER = 60.0
DYNWIND(nw) = 4
DYNWIND(dw) = 2
DYNWIND(dwc) = 1
Conn Bal Fact = 2
Log BNN Conn = 0

=>
F1=HELP F2=SUBAREA F3=RETURN F4=BNN IDBLK-IDNUM F5=MODIFY F6=ROLL
F7=MAC ADDR F8=SNA STATIONS (ALL TICs) F9=ALT-PAGE F10=HEX F11=ALT-PFKs
ENTER=SNA STATIONS F12=REFRESH/TRAFFIC RATES PA1=EXIT PA2=LOG
    
```

Figure 6-28. ATUTP1 Token-Ring TIC Details Page 1 Panel

Description

The ATUTP1 Token-Ring TIC Details Page 1 panel, which is available for NCP V5R4 or later releases, displays detailed information for a specific type 1, type 2, or type 3 TIC. A 3746 Model 900 is a type 3 TIC.

To display this panel:

- On the ATUSC4 3746 Model 900 Adapters panel, as shown on page 4-237, place the cursor under the line address for a TRP or CBTRP adapter and press Enter.
- On the ATUTC Token-Ring Adapter List panel, as shown on page 4-278, place the cursor under a TIC address and press Enter.
- From the ATUTP2 Token-Ring TIC Details Page 2 panel, as shown on page 4-319, press F9.

See the descriptions of the panels for more information.

Tuning Fields

T/R LOCADD (modifiable starting with NCP V7R5)

MAC address of the TIC, as defined by the LOCADD keyword on the LINE statement.

NDF Default

None

Minimum

X'4000 0000 0001'

Maximum

X'7FFF FFFF FFFF'

Considerations

- Can be modified only for subarea stations.
- The physical line must be inactive before this field can be modified.

Tuning Suggestions

Use this tuning field to correct an error in the LOCADD keyword without regenerating the NCP.

TITIMER (starting with NCP V7R1)

Inactivity timer interval (TI), in seconds, that NCP is to wait for a transmitted frame from an adjacent station before sending a poll command, as defined by the TITIMER keyword on the LINE statement. The *time_interval* can be expressed as a whole number, or to the nearest 10th of a second.

NDF Default

60

Minimum

10

Maximum

1500

Considerations

- For the 3745, can be modified at any time.
- For the 3746 Model 900, the line must be inactive before this field can be modified.
- As logical lines or stations that are associated with this particular physical line become active, they will begin using the new *TITIMER* value. This change does not affect logical lines or stations that are already active.

Tuning Suggestions

In most cases the default value is the best choice. If the TI timer value is too long, NCP can be delayed in detecting a failure in the adjacent station. If the TI timer value is too short, congestion can occur.

DYNWIND(nw) (starting with NCP V7R1)

Number of frames that must be received and acknowledged by the adjacent device before the sending NCP increases the IEEE 802.2 LLC working window value. When the sending NCP receives acknowledgements for *nw* consecutive I-frames, the working window value is increased until it reaches the value specified by MAXOUT for subarea connections, or the value specified in the VTAM switched major node for peripheral connections.

For a physical Token-Ring line, for NCP V7R1 through V7R4, the value in this field is defined by the *nw* suboperand of the DYNWIND keyword on the

GROUP or LINE statement. For NCP V7R1 and V7R2, the value applies to all logical lines and stations associated with that physical line.

For a logical subarea Token-Ring station, for NCP V7R3 or later releases, the value in this field is defined by the *nw* suboperand of the DYNWIND keyword on the GROUP, LINE, or PU statement. For a peripheral station, for NCP V7R3 and later releases, the value is defined in the VTAM switched major node. Or if it is not defined in VTAM, the value is defined on the physical station's GROUP or LINE statement. Beginning with NCP V7R5, DYNWIND(*nw*) is also allowed on the PU statement for the physical station.

NDF Default

4

Minimum

1

Maximum

8

Considerations

- For the 3745, can be modified at any time.
- For the 3746 Model 900, the line must be inactive before this field can be modified.
- For NCP V7R1 and V7R2, as logical lines or stations that are associated with this particular physical line become active, they will begin using the new *nw* value. This change does not affect logical lines or stations that are already active.
- For NCP V7R3 or later releases, as logical peripheral lines or stations that are associated with this particular physical line become active, they will begin using the new *nw* value, unless they are peripheral stations whose DYNWIND(*nw*) values are defined in the VTAM switched major node. This change does not affect logical lines or stations that are already active.

Tuning Suggestions

In most cases, the default value is the best choice. However, in a Token-Ring network where congestion is frequent or long-lasting (for example, longer than 30 seconds), increase DYNWIND(*nw*) to help alleviate congestion. This slows the transmission rate of affected stations for a longer time to give the network time to recover. In a Token-Ring network where congestion is infrequent or lasts for a very short time, decrease DYNWIND(*nw*) to help the NCP recover more quickly.

DYNWIND(dw) (starting with NCP V7R8; TIC1 and TIC2 resources only)

Value by which the sending NCP divides, or percentage by which the sending NCP reduces, the IEEE 802.2 LLC working window value when frame loss occurs.

The value in this field is defined by the *dw* suboperand of the DYNWIND keyword on the GROUP, LINE, or PU statement for a logical subarea Token-Ring station. For a peripheral station, the value is defined in the VTAM switched major node, or if not defined in VTAM, on the GROUP, LINE, or PU statement for the Token-Ring physical station.

NDF Default

1

Valid Values

1, 2, 4, 6, 8, 12, 16, 25, 50, 75, 87, 93

Considerations

- 1 is a special value which indicates that the working window value should be set to 1 when frame loss is detected.
- This field can be modified at any time.
- Not modifiable for 3746 Model 900 lines.
- As logical peripheral lines or stations that are associated with this particular physical line become active, they will begin using the new dw value, unless they are peripheral stations whose DYNWIND(dw) values are defined in the VTAM switched major node. This change does not affect logical lines or stations that are already active.

Tuning Suggestions

In most cases, the default value is the best choice. Also, if possible, you should first tune DYNWIND(dwc) to try to alleviate congestion. The loss of frames (dw) is a more severe condition than the congestion indicated by receiving RNR (dwc). Mistuning DYNWIND(dw) might have a greater effect on throughput than mistuning DYNWIND(dwc).

However, when congestion is frequent or long-lasting (for example, longer than 30 seconds), you might want to increase DYNWIND(dw) to help alleviate congestion. This slows the transmission rate of affected stations for a longer time to give the network more time to recover. When congestion is infrequent or lasts for a very short time, decrease DYNWIND(dw) to help the NCP recover more quickly.

DYNWIND(dwc) (starting with NCP V7R8; TIC1 and TIC2 resources only)

Value by which the sending NCP divides, or percentage by which the sending NCP reduces, the IEEE 802.2 LLC working window value when congestion is assumed. Congestion is assumed from the time an RNR frame is received until the time an RR frame is received. The working window is reduced only once for each period of congestion.

The value in this field is defined by the *dwc* suboperand of the DYNWIND keyword on the GROUP, LINE, or PU statement for a logical subarea Token-Ring station. For a peripheral station, the value is defined in the VTAM switched major node, or if not defined in VTAM, on the GROUP, LINE, or PU statement for the physical Token-Ring station.

NDF Default

0

Valid Values

0, 1, 2, 4, 6, 8, 12, 16, 25, 50, 75, 87, 93

Considerations

- For 3745 Token-Ring (NTRI) lines, congestion begins when the first RNR frame is received. The congestion ends when an RR frame is received. The working window is reduced only once per period of congestion.

- 0 is a special value, and is the default, to indicate that NCP will not reduce the working window during congestion.
- 1 is a special value which indicates that the working window value will be set to 1 during congestion.
- This field can be modified at any time.
- Not modifiable for 3746 Model 900 lines.
- As logical peripheral lines or stations that are associated with this particular physical line become active, they will begin using the new dwc value, unless they are peripheral stations whose DYNWIND(dwc) values are defined in the VTAM switched major node. This change does not affect logical lines or stations that are already active.

Tuning Suggestions

In most cases, the default value is the best choice. However, when congestion is frequent or long-lasting (for example, longer than 30 seconds), increase DYNWIND(dwc) to help alleviate congestion. This slows the transmission rate of affected stations for a longer time to give the network more time to recover. When congestion is infrequent or lasts for a very short time, decrease DYNWIND(dwc) to help the NCP recover more quickly.

Conn Bal Fact (starting with NCP V7R6)

Connection balancing factor for the TIC as specified by the BALANCE keyword on the GROUP or LINE definition statement.

NDF Default

0

Minimum

0

Maximum

16

Considerations

- For 3745, can be modified at any time.
- For 3746 Model 900, the physical line must be inactive before this field can be modified.

Tuning Suggestions

- A zero balancing factor means that the TIC does not perform connection balancing and responds normally to received peripheral route discovery frames.
- Do not specify a balancing factor when the Token-Ring physical line has a unique locally administered MAC address.
- Specify a nonzero balancing factor when you want a Token-Ring physical line with a duplicate locally administered MAC address to participate in the balancing of all peripheral connections (established via incoming call requests) across all associated duplicate TICs.
- All associated duplicate TICs must have nonzero balancing factors, in order for the balancing mechanism to function properly, if any one of the associated duplicate TICs is performing connection balancing.

- Specify the same balancing factor for all duplicate TICs to achieve an approximate symmetrical distribution. Specifying differing balancing factors might result in a weighted distribution, depending on the network configuration.
- For 3746 Model 900, AUTO is a special value specifying that the 3746 Model 900 will use its auto-adaptive balancing algorithm.
- For more information about connection balancing, see *NCP, SSP, and EP Resource Definition Guide*.

PF Keys

PF Key Selection Number 1

This is the default set of PF keys for this panel.

F1=HELP

Displays online help for this panel.

F2=SUBAREA

Displays the ATUTA Token-Ring SNA Station List panel, as shown on page 4-273, to show all subareas with connections through this TIC.

F3=RETURN

Returns to the previous NTuneMON panel.

F4=BNN IDBLK-IDNUM

Displays the ATUTA Token-Ring SNA Station List panel, as shown on page 4-273, to show the IDBLK-IDNUM for all SNA logical stations going through this TIC.

F5=MODIFY

Available when the operator has tuning authority and NTuneNCP is included. For more information, refer to Chapter 5, Using the NTuneNCP Tuning Feature.

Updates the NCP tuning parameter with the modified value. If the modification is not valid, the field turns reverse-video pink, and you are prompted to correct the value and resubmit it.

F6=ROLL

Returns to the NetView command line without exiting NTuneMON. To return to NTuneMON from the NetView program, press F6=ROLL or enter **ATUNEMON** on the NetView command line.

F7=MAC ADDR

Displays the ATUTA Token-Ring SNA Station List panel, as shown on page 4-273, to show MAC addresses for all SNA logical stations associated with this TIC. This resets your default and dual view from the ATUTC Token-Ring Adapter List panel, as shown on page 4-278.

F8=SNA STATIONS (ALL TICs)

Displays the ATUTA Token-Ring SNA Station List panel, as shown on page 4-273, to show information on the SNA logical stations associated with this TIC. The stations displayed are determined by the value in the STATUS DEFAULT field on the ATUTC Token-Ring Adapter List panel, as shown on page 4-278. The information displayed for each station is determined by the values in the VIEW DEFAULT and (DUAL) fields on the ATUTC Token-Ring Adapter List panel.

F9=ALT-PAGE (NCP V7R3 or later releases; type 1 or type 2 TIC)

Scrolls forward to the ATUTP2 Token-Ring TIC Details Page 2 panel, as shown on page 4-319, to show more detailed information on this TIC.

F10=HEX

Displays the ATUDP Hexadecimal Storage Display panel, as shown on page 4-68, to show the physical link control block (PLB) for a type 1 or type 2 TIC, or the Token-Ring line block extension (TLB) for a type 3 TIC.

F11=ALT-PFKs

Resets some of the PF keys on this panel to perform different functions. These alternate PF keys are shown in Figure 6-29.

ENTER=SNA STATIONS

Displays the ATUTA Token-Ring SNA Station List panel, as shown on page 4-273, to show information on the SNA logical stations associated with this TIC. The stations displayed are determined by the value in the STATUS DEFAULT field on the ATUTC Token-Ring Adapter List panel, as shown on page 4-278. The information displayed for each station is determined by the values in the VIEW DEFAULT and (DUAL) fields on the ATUTC Token-Ring Adapter List panel.

F12=REFRESH/TRAFFIC RATES

Refreshes the information on this panel.

Note: Traffic rates are refreshed when this key is pressed from the ATUTP2 Token-Ring TIC Details Page 2 panel, as shown on page 4-319.

PA1=EXIT

Exits NTuneMON.

PA2=LOG

Saves the information on this panel to the NetView log.

PF Key Selection Number 2

Figure 6-29 shows the second set of PF keys for the ATUTP1 Token-Ring TIC Details Page 1 panel. These alternate functions are enabled when you press F11=ALT-PFKs in the first PF key set. The alternate functions are described following the figure.

```
=> ATUM022 PF keys have been set to selection number 2
F1=HELP          F3=RETURN  F4=RESET MIN/MAX  F5=MODIFY  F6=ROLL
                F8=FR/TR LINES (ALL TICs)  F9=ALT-PAGE  F10=HEX  F11=ALT-PFKs
ENTER=FR/TR LINES  F12=REFRESH/TRAFFIC RATES  PA1=EXIT  PA2=LOG
```

Figure 6-29. PF Key Selection Number 2 for the ATUTP1 Token-Ring TIC Details Page 1 Panel

F1=HELP

Displays online help for this panel.

F2=TR IP STATS (starting with NCP V7R1; IP over Token Ring)

Displays the ATUTI Token-Ring IP Statistics panel, as shown on page 4-298, to show Token-Ring IP statistics.

F3=RETURN

Returns to the previous NTuneMON panel.

F4=RESET MIN/MAX (NCP V7R3 or later releases; type 1 or type 2 TIC)

Available when the operator has tuning authority and NTuneNCP is included. For more information, refer to Chapter 5, Using the NTuneNCP Tuning Feature.

Valid only from the ATUTP2 Token-Ring TIC Details Page 2 panel.

F5=MODIFY

Available when the operator has tuning authority and NTuneNCP is included. For more information, refer to Chapter 5, Using the NTuneNCP Tuning Feature.

Updates the NCP tuning parameter with the modified value. If the modification is not valid, the field turns reverse-video pink, and you are prompted to correct the value and resubmit it.

F6=ROLL

Returns to the NetView command line without exiting NTuneMON. To return to NTuneMON from the NetView program, press F6=ROLL or enter **ATUNEMON** on the NetView command line.

F7=IP DETAILS (starting with NCP V7R1; IP over Token Ring)

Shows the ATUID IP Interface Information Detail panel, as shown on page 4-164, to show detailed information about an IP interface that is connected to this physical Token-Ring.

F8=FR/TR LINES (ALL TICs) (NCP V7R3 or later releases; frame relay over Token Ring; type 1 and type 2 TICs)

Displays the ATUTF NTRI Frame Handler Logical Lines panel, as shown on page 4-291, to show information on the NTRI frame handler logical lines associated with all type 1 and type 2 TICs.

F9=ALT-PAGE (NCP V7R3 or later releases; type 1 or type 2 TIC)

Scrolls forward to the ATUTP2 Token-Ring TIC Details Page 2 panel, as shown on page 4-319, to show more detailed information on this TIC.

F10=HEX

Displays the ATUDP Hexadecimal Storage Display panel, as shown on page 4-68, to show the physical link control block (PLB) for a type 1 or type 2 TIC, or the Token-Ring line block extension (TLB) for a type 3 TIC.

F11=ALT-PFKs

Resets the PF keys on this panel to perform their original functions as shown under "PF Keys" on page 6-175.

ENTER=FR/TR LINES (NCP V7R3 or later releases; frame relay over Token Ring; type 1 or type 2 TIC)

Displays the ATUTF NTRI Frame Handler Logical Lines panel, as shown on page 4-291, to show information on the NTRI frame handler logical lines associated with this TIC.

F12=REFRESH/TRAFFIC RATES

Refreshes the information on this panel.

Note: Traffic rates are refreshed when this key is pressed from the ATUTP2 Token-Ring TIC Details Page 2 panel, as shown on page 4-319.

PA1=EXIT

Exits NTuneMON.

ATUTP2 Token-Ring TIC Details Page 2 Panel

PA2=LOG

Saves the information on this panel to the NetView log.

ATUTP2 Token-Ring TIC Details Page 2 Panel

Basic fast-path commands: None

Tuning fields: COMRATE

```
ATUTP2  A71TEST  Token-Ring TIC Details Page 2  NTuneMON V2R4  14:31
                                                Elapsed Time = 0
Default View= MAC  Dual=  Status= ACTIVE  TIC= 1088 Find=

      FRAME INFORMATION
      MAXTSL = 4096  RCVBUFC = 8192  DATABLK = 2048  MAXFRAME = 4096
      COMRATE  Max Size  Min Size  Number of  Estimated
               Frame Sent  Frame Sent  Frames Sent  Bytes Sent
      TIC      N/A        156      156         1           -
      SNA      1          -         -           -           -
      FR       1          -         -           -           -

=> ATUM017 Press F12 to see Traffic or Polling rates
F1=HELP  F2=SUBAREA  F3=RETURN  F4=BNN IDBLK-IDNUM  F5=MODIFY  F6=ROLL
F7=MAC ADDR  F8=SNA STATIONS (ALL TICs)  F9=ALT-PAGE  F10=HEX  F11=ALT-PFKs
ENTER=SNA STATIONS  F12=REFRESH/TRAFFIC RATES  PA1=EXIT  PA2=LOG
```

Figure 6-30. ATUTP2 Token-Ring TIC Details Page 2 Panel

Description

The ATUTP2 Token-Ring TIC Details Page 2 panel, which is available for NCP V7R3 or later releases, displays detailed information for a specific type 1 or type 2 TIC.

To display this panel: From the ATUTP1 Token-Ring TIC Details Page 1 panel, as shown on page 4-310, press F9.

Tuning Fields

COMRATE (starting with NCP V7R3)

Relative transmit priority for a protocol as represented by a Token-Ring physical station (SNA, IP, or frame relay). The transmit priority is defined by the *priority* suboperand of the COMRATE keyword on the PU statement.

NDF Default

1

Minimum

1

Maximum

64

Considerations

The value of the *priority* suboperand is multiplied by the value of the DATABLK keyword on the LINE statement to determine the guaranteed minimum number of bytes that a protocol can transmit before a different protocol must be given a transmission opportunity.

Tuning Suggestions

Unless you anticipate high volumes for a protocol, you should specify similar rates for all protocols.

PF Keys**PF Key Selection Number 1**

This is the default set of PF keys for this panel.

F1=HELP

Displays online help for this panel.

F2=SUBAREA

Displays the ATUTA Token-Ring SNA Station List panel, as shown on page 4-273, to show all subareas with connections through this TIC.

F3=RETURN

Returns to the previous NTuneMON panel.

F4=BNN IDBLK-IDNUM

Displays the ATUTA Token-Ring SNA Station List panel, as shown on page 4-273, to show the IDBLK-IDNUM for all SNA logical stations going through this TIC.

F5=MODIFY

Available when the operator has tuning authority and NTuneNCP is included. For more information, refer to Chapter 5, Using the NTuneNCP Tuning Feature.

Updates the NCP tuning parameter with the modified value. If the modification is not valid, the field turns reverse-video pink, and you are prompted to correct the value and resubmit it.

F6=ROLL

Returns to the NetView command line without exiting NTuneMON. To return to NTuneMON from the NetView program, press F6=ROLL or enter **ATUNEMON** on the NetView command line.

F7=MAC ADDR

Displays the ATUTA Token-Ring SNA Station List panel, as shown on page 4-273, to show MAC addresses for all SNA logical stations associated with this TIC. This resets your default and dual view from the ATUTC Token-Ring Adapter List panel, as shown on page 4-278.

F8=SNA STATIONS (ALL TICs)

Displays the ATUTA Token-Ring SNA Station List panel, as shown on page 4-273, to show information on the SNA logical stations associated with this TIC. The stations displayed are determined by the value in the STATUS DEFAULT field on the ATUTC Token-Ring Adapter List panel, as shown on page 4-278. The information displayed for each station is determined by the values in the VIEW DEFAULT and (DUAL) fields on the ATUTC Token-Ring Adapter List panel.

F9=ALT-PAGE

Scrolls back to the ATUTP1 Token-Ring TIC Details Page 1 panel as shown on page 4-310, to show more detailed information on this TIC.

F10=HEX

Displays the ATUDP Hexadecimal Storage Display panel, as shown on page 4-68, to show the physical link control block (PLB) for a type 1 or type 2 TIC, or the Token-Ring line block extension (TLB) for a type 3 TIC.

F11=ALT-PFKs

Resets some of the PF keys on this panel to perform different functions. These alternate PF keys are shown in Figure 6-31.

ENTER=SNA STATIONS

Displays the ATUTA Token-Ring SNA Station List panel, as shown on page 4-273, to show information on the SNA logical stations associated with this TIC. The stations displayed are determined by the value in the STATUS DEFAULT field on the ATUTC Token-Ring Adapter List panel, as shown on page 4-278. The information displayed for each station is determined by the values in the VIEW DEFAULT and (DUAL) fields on the ATUTC Token-Ring Adapter List panel.

F12=REFRESH/TRAFFIC RATES

Refreshes the information on this panel and displays traffic rates.

PA1=EXIT

Exits NTuneMON.

PA2=LOG

Saves the information on this panel to the NetView log.

PF Key Selection Number 2

Figure 6-31 shows the second set of PF keys for the ATUTP2 Token-Ring TIC Details Page 2 panel. These alternate functions are enabled when you press F11=ALT-PFKs in the first PF key set.

```
=> ATUM022 PF keys have been set to selection number 2
F1=HELP          F3=RETURN  F4=RESET MIN/MAX  F5=MODIFY  F6=ROLL
                F8=FR/TR LINES (ALL TICs)  F9=ALT-PAGE  F10=HEX  F11=ALT-PFKs
ENTER=FR/TR LINES  F12=REFRESH/TRAFFIC RATES  PA1=EXIT  PA2=LOG
```

Figure 6-31. PF Key Selection Number 2 for the ATUTP2 Token-Ring TIC Details Page 2 Panel

F1=HELP

Displays online help for this panel.

F2=TR IP STATS (IP over Token Ring)

Displays the ATUTI Token-Ring IP Statistics panel, as shown on page 4-298, to show Token-Ring IP statistics.

F3=RETURN

Returns to the previous NTuneMON panel.

F4=RESET MIN/MAX

Available when the operator has tuning authority and NTuneNCP is included. For more information, refer to Chapter 5, Using the NTuneNCP Tuning Feature.

Resets the values of the Max Size Frame Sent and Min Size Frame Sent fields. After resetting the fields, NTuneMON automatically refreshes the

panel. If new traffic rates are available, they are displayed. Otherwise, NTuneMON displays a dash (–) until new traffic rates are available and you press F12 or reenter the panel to display the new rates. To reset these fields, place the cursor under the TIC or protocol you want on the ATUTP2 Token-Ring TIC Details Page 2 panel and press F4.

F5=MODIFY

Available when the operator has tuning authority and NTuneNCP is included. For more information, refer to Chapter 5, Using the NTuneNCP Tuning Feature.

Updates the NCP tuning parameter with the modified value. If the modification is not valid, the field turns reverse-video pink, and you are prompted to correct the value and resubmit it.

F6=ROLL

Returns to the NetView command line without exiting NTuneMON. To return to NTuneMON from the NetView program, press F6=ROLL or enter **ATUNEMON** on the NetView command line.

F7=IP DETAILS (IP over Token Ring)

Shows the ATUID IP Interface Information Detail panel, as shown on page 4-164, to show detailed information about an IP interface that is connected to this physical Token-Ring.

F8=FR/TR LINES (ALL TICs) (frame relay over Token Ring; type 1 and type 2 TICs)

Displays the ATUTF NTRI Frame Handler Logical Lines panel, as shown on page 4-291, to show information on the NTRI frame handler logical lines associated with all type 1 and type 2 TICs.

F9=ALT-PAGE

Scrolls back to the ATUTP1 Token-Ring TIC Details Page 1 panel, as shown on page 4-310, to show more detailed information on this TIC.

F10=HEX

Displays the ATUDP Hexadecimal Storage Display panel, as shown on page 4-68, to show the physical link control block (PLB) for a type 1 or type 2 TIC, or the Token-Ring line block extension (TLB) for a type 3 TIC.

F11=ALT-PFKs

Resets the PF keys on this panel to perform their original functions, as shown under “PF Keys” on page 6-179.

ENTER=FR/TR LINES (frame relay over Token Ring)

Displays the ATUTF NTRI Frame Handler Logical Lines panel, as shown on page 4-291, to show information on the NTRI frame handler logical lines associated with this TIC.

F12=REFRESH/TRAFFIC RATES

Refreshes the information on this panel and displays traffic rates.

PA1=EXIT

Exits NTuneMON.

PA2=LOG

Saves the information on this panel to the NetView log.

ATUVA Virtual Route Control Block Details Panel

Basic fast-path commands: None

Tuning fields: VR Window Size Max, VR Window Size Min

```

ATUVA  A27GENC  Virtual Route Control Block Details  NTuneMON V2R6  14:49

VR ID / Priority = 0.0
Network ID      = NETA      Receive Buffer Count = 0
Dest Subarea   = 1        Xmit Queue Count    = 0
VR Hop count   = 0
Next Receive Seq Number = 013A      Next Send Seq Number = 0D36

VR Window Size Max = 45      VR Piu Pool Threshold = 47
VR Window Route Size = 45    VR Piu Pool Count     = 0
VR Window Size Min = 15      VR Window Count       = 9

VR Status Information

VR Alert Information Details
VR Cong INT in Sec.= 0      VR Consg Held in SEC=0
Number of days = 0 Hour = 0 Min = 0 Sec = 0

Accum Xmit Time = 0
Forward Max Packet = 0      Receive Max Packet = 0
=>
F1=HLP F3=RTN F5=MODIF F6=ROLL F9=Alertimer F10=HEX F12=RFSH PA1=EXIT PA2=LOG
    
```

Figure 6-32. ATUVA Virtual Route Control Block Details Panel

Description

The ATUVA Virtual Route Control Block Details panel displays detailed information on a virtual route control block.

To display this panel: On the ATUVR Virtual Route panel, as shown on page 4-334, place the cursor under a virtual route and press Enter.

Tuning Fields

VR Window Size Max (NCP V4R3.1 or later releases)

Maximum virtual route window size, as defined by the VRPWSnm keyword on the NCP PATH statement or by the VTAM PATH or VPATH statement.

NDF Default

None

Minimum

1

Maximum

255

Considerations

The value of VR Window Size Max must be greater than the value of VR Window Size Min.

Tuning Suggestions

You might want to increase VR Window Size Max for the sending NCP when:

- The value of VR Window Route Size (the current window size) has reached the value of VR Window Size Max.
- There are a number of PIUs waiting to be transmitted on the virtual route outbound queue (Xmit Queue Count field).

Before increasing VR Window Size Max, make sure that, along the virtual route:

- There are enough available NCP buffers.
- There are enough resources in all NCPs and VTAMs.
- There is no virtual route or transmission group congestion.

VR Window Size Min (NCP V4R3.1 or later releases)

Minimum virtual route window size, as defined by the VRPWSnm keyword on the NCP PATH statement or by the VTAM PATH or VPATH statement.

NDF Default

None

Minimum

1

Maximum

255

Considerations

The value of VR Window Size Min must be less than the value of VR Window Size Max.

Note: When you modify the virtual route minimum window size, the threshold limit shown in the VR PIU Pool Threshold field is also modified using the following formula:

$$\text{threshold} + ((\text{new min window size} - \text{old min window size}) \times 3)$$

The new threshold must be greater than 9.

Tuning Suggestions

None.

PF Keys

F1=HLP

Displays online help for this panel.

F3=RTN

Returns to the previous NTuneMON panel.

F5=MODIF

Available when the operator has tuning authority and NTuneNCP is included. For more information, refer to Chapter 5, Using the NTuneNCP Tuning Feature.

Updates the NCP tuning parameter with the modified value. If the modification is not valid, the field turns reverse-video pink, and you are prompted to correct the value and resubmit it.

ATUVA Virtual Route Control Block Details Panel

F6=ROLL

Returns to the NetView command line without exiting NTuneMON. To return to NTuneMON from the NetView program, press F6=ROLL or enter **ATUNEMON** on the NetView command line.

F9=Alertimer

Displays the ATUVT VR Alert Timer panel, to show the virtual route timer values for the network. Place the cursor under the name of a network and press F9.

F10=HEX

Displays the ATUDP Hexadecimal Storage Display panel, as shown on page 4-68, to show a virtual route control block (VRB).

F12=RFSH

Refreshes the information on this panel.

PA1=EXIT

Exits NTuneMON.

PA2=LOG

Saves the information on this panel to the NetView log.

ATUVT VR Alert Timer Panel

Basic fast-path commands: None

Tuning fields: VR Alert Timer, VR Deact Timer, VR Transmit PIU Queue, Alert Time Limit, Deact Time Limit

```

ATUVT  A27GENC  VR Alert Timer Panel  NTuneMON V2R6  14:50

Network Name =  NETA

VR Alert for Transmission Priority 0
VR Alert Timer   =  0
VR Transmit PIU Queue =  0
VR Deact Timer   =  0

VR Alert for Transmission Priority 1
VR Alert Timer   =  0
VR Transmit PIU Queue =  0
VR Deact Timer   =  0

VR Alert for Transmission Priority 2
VR Alert Timer   =  0
VR Transmit PIU Queue =  0
VR Deact Timer   =  0

-----
TGTIMER - MLTG Performance Degraded Timer Values
Alert Time Limit   =  60
Deact Time Limit   =  0

=>
F1=HELP  F3=RETURN  F5=MODIF  F6=ROLL  F10=HEX  F12=REFRESH  PA1=EXIT  PA2=LOG

```

Figure 6-33. ATUVT VR Alert Timer Panel

Description

The ATUVT VR Alert Timer panel, which is available starting with NCP V7R8, enables the viewing and modification of VR timer values and TG timer values.

To display this panel:

- On the ATUNG HSCBs and GWNAUs panel, as shown on page 4-195, press F9.
- On the ATUVR Virtual Route panel, as shown on page 4-334, press F9.
- On the ATUVA Virtual Route Control Block Details panel, as shown on page 4-331, press F9.

Tuning Fields

VR Alert Timer

The virtual route congestion time limit, in seconds. If the virtual route is congested for this length of time, NCP sends an alert to the owning host.

NDF Default

0

Minimum

0

ATUVT VR Alert Timer Panel

Maximum

86400

Considerations

- 0 is a special value, and is the default, to indicate that NCP does not send virtual route alerts.
- If the value of this field is 0, then the value of the VR Transmit PIU Queue field must be 0.
- If you enter a value that is not a multiple of 10, the value is rounded up to the nearest multiple of 10.
- The maximum of 86400 equals a single day.

Tuning Suggestions

None.

VR Deact Timer

The virtual route deactivation time limit, in seconds. If the virtual route is congested for this length of time, NCP deactivates it.

NDF Default

0

Minimum

0

Maximum

86400

Considerations

- 0 is a special value, and is the default, to indicate that NCP does not deactivate virtual routes because of a held condition.
- If you enter a value that is not a multiple of 10, the value is rounded up to the nearest multiple of 10.
- If this value is greater than 0, then it must be equal to or greater than the value of the VR Alert Timer field.
- The maximum of 86400 equals a single day.

Tuning Suggestions

None.

VR Transmit PIU Queue

The number of PIUs that constitutes a congestion condition.

NDF Default

0

Minimum

0

Maximum

255

Considerations

- 0 is a special value, and is the default, to indicate that NCP does not send alerts for congested virtual routes.
- If the value of the VR Alert Timer field is 0, then the value of this field must be 0.

Tuning Suggestions

None.

Alert Time Limit

The MLTG-performance-degraded alert time limit, in seconds. Specified by the first suboperand of the TGTIMER keyword on the BUILD or NETWORK definition statement. If the MLTG's performance is degraded for this length of time, then NCP sends an alert to the owning hosts.

NDF Default

60

Minimum

0

Maximum

2550

Considerations

- 0 is a special value to indicate that NCP does not send MLTG performance degraded alerts.
- If the value of this field is 0, then the value of the Deact Time Limit field must be 0.
- If you enter a value that is not a multiple of 10, the value is rounded up to the nearest multiple of 10.

Tuning Suggestions

None.

Deact Time Limit

The MLTG deactivation time limit, in seconds. Specified by the second suboperand of the TGTIMER keyword on the BUILD or NETWORK definition statement. If the MLTG's performance is degraded for this length of time, NCP deactivates all links in the MLTG and notifies the owners of each link.

NDF Default

0

Minimum

0

Maximum

2550

Considerations

- 0 is a special value, and is the default, to indicate that NCP will not automatically deactivate the links in an MLTG even if the MLTG's performance is considered to be degraded.

ATUVT VR Alert Timer Panel

- If this value is greater than 0, then it must be equal to or greater than the value of the Alert Time Limit field.
- If the value of the Alert Time Limit field is 0, then the value of the Deact Time Limit field must be 0.
- If you enter a value that is not a multiple of 10, the value is rounded up to the nearest multiple of 10.

Tuning Suggestions

None.

PF Keys

F1=HELP

Displays online help for this panel.

F3=RETURN

Returns to the previous NTuneMON panel.

F5=MODIFY

Available when the operator has tuning authority and NTuneNCP is included. For more information, refer to Chapter 5, Using the NTuneNCP Tuning Feature.

Updates the NCP tuning parameter with the modified value. If the modification is not valid, the field turns reverse-video pink, and you are prompted to correct the value and resubmit it.

F6=ROLL

Returns to the NetView command line without exiting NTuneMON. To return to NTuneMON from the NetView program, press F6=ROLL or enter **ATUNEMON** on the NetView command line.

F10=HEX

Displays the ATUDP Hexadecimal Storage Display panel, as shown on page 4-68, to show the RMB control block.

F12=RFSH

Refreshes the information on this panel.

PA1=EXIT

Exits NTuneMON.

PA2=LOG

Saves the information on this panel to the NetView log.

ATUXP X.25 MCH Physical Line Details Page 1 Panel

This panel has two forms:

- Figure 6-34 shows the panel that displays when the physical line is defined as an NPSI line.
- Figure 6-35 on page 6-190 shows the panel that displays when the physical line is defined as an X.25 ODLC line.

Basic fast-path commands: None

Tuning fields: Line Speed, NRZI, Clockng

```

ATUXP  A04SDX2  X.25 MCH Physical Line Details Pgl  NTuneMON V2R5  09:25
          CCU = 1                      Buffers = 1

Line Address= 2243      Line Name   = MCH2243      MCH Name   = MCH2243
Status        = INACTIVE  Element Addr = 57          Fr Modulo  = 128
Line Adapter= CLP       Line Speed  = 75000      Clockng    = EXT
Frame Window= 127      NRZI       = YES          Max Frame  = 4100
                                     Network Type = 1
FPTI MCH     = NO        X.21 Switched= NO      Link Modulo = 128
TP Timer     = 10        TD Timer    = 3

-----
MCH Link State and Substate
MCH Idle                    No frames allowed

-----
SYS Generated Parm List
LAC Trace Active = YES  D bit Support = YES  Translation Type = NONE
MCH working as  = DCE  LCN 0 Used   = NO   RNR Packet      = YES
DM Supported    = YES  Dial-by-    = N/A  Reset PVC       = NO
Interwork Support= NO  Packet Modulo = 128

=>
F1=Help  F2= MCH Stat F3=Return  F5=MODIFY  F6=Roll  F10=Hex
ENTER=More details  F11=Virtual Circuit List  F12=Refresh  PA1=Exit  PA2=Log
    
```

Figure 6-34. ATUXP X.25 MCH Physical Line Details Page 1 Panel for NPSI

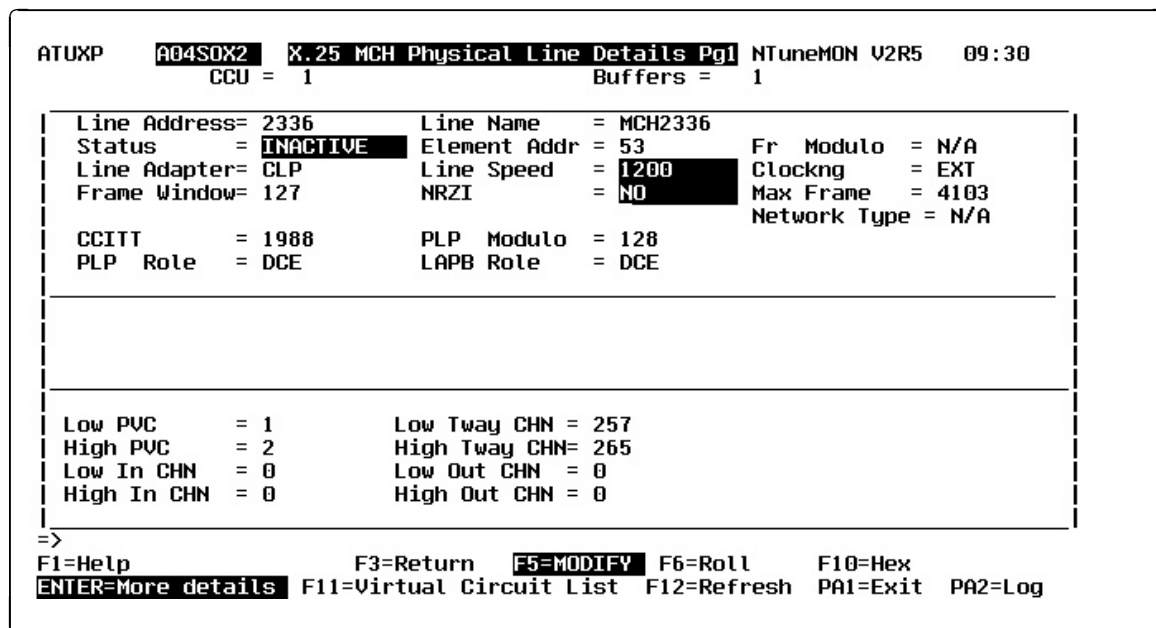

Figure 6-35. ATUXP X.25 MCH Physical Line Details Page 1 Panel for X.25 ODLC

Description

The ATUXP X.25 MCH Physical Line Details Page 1 panel displays detailed information about an X.25 multichannel (MCH) physical line. This panel is available starting with:

- NCP V7R4 for X.25 ODLC resources
- NCP V7R2, for NPSI X.25 resources with NPSI V3R7 or later releases

To display this panel: On the ATUXL X.25 MCH Physical Line List panel, as shown on page 4-350, place the cursor under an MCH and press Enter.

Tuning Fields

Line Speed (tunable starting with NCP V7R7)

Data rate for a line in bits per second, as defined by the *rate* suboperand of the SPEED keyword on the LINE statement. This data rate is the rate at which the devices communicate with the communication controller.

NDF Default

None

Valid Values

The line speed that is actually used by NCP might differ from the line speed that you enter on this panel. To see the line speeds that NCP uses, and to decide which speed value you should specify, refer to the discussion of the SPEED keyword on the LINE statement in the *Resource Definition Reference* manual. The remainder of this “Valid Values” section discusses the **SPEED value that is displayed by NTuneMON.**

Beginning with NCP V7R7, NTuneMON displays the speed value exactly as you coded it in the gen or modified it on this panel.

For NCP V7R6 and earlier releases,

- See Table 6-13 on page 6-191 to find the displayed values for SPEED for X.25 lines (TSS and HPTSS). These values are valid only for NCP V5R4 and later.
- See Table 6-14 to find the displayed speed values for the 3746 Model 900 when CLOCKNG=INT or CLOCKNG=DIRECT.
- See Table 6-15 on page 6-192 to find the displayed speed values for the 3746 Model 900 when CLOCKNG=EXT. When CLOCKNG=EXT, SPEED values for 3746 Model 900 X.25 lines can be tuned to any value from 600 to 2048000. However, for NCP V7R6 and earlier, after you enter the value, it is converted and displayed as shown in Table 6-15.

Values that can be displayed but cannot be entered are:

NOT DEFIN

SPEED has not been coded or tuned to a valid value.

RPQ

SPEED is a non-standard value set by a special arrangement with IBM.

Table 6-13. Displayed SPEED Values for TSS and HPTSS Adapters when VERSION<V7R7 and VERSION>V5R4

Data Rate (SPEED)	CLOCKNG=INT	CLOCKNG=DIRECT	CLOCKNG=EXT ²
50	■	■	■
75		■	■
100		■	■
110	■	■	■
134	■	■	■
200	■	■	■
300	■	■	■
600	■	■	■
1200	■	■	■
2400	■	■	■
4800	■	■	■
9600		■	■
19200		■	■
38400		■	■
55855		■	■
245760		■	■
1843200 ¹		■	■

Notes:

¹ This speed is valid only for HPTSS lines.

² If you specified a value other than the ones shown in this table, the value you specified will be displayed as follows: If the value is less than 1843200, the panel displays the next highest valid value in the table. For example, if 60 was specified, the panel display will be 75. If a value greater than 1843200 was specified for SPEED, the panel display will be 1843200.

Table 6-14 (Page 1 of 2). Displayed SPEED Values for 3746 Model 900 when CLOCKNG=INT or CLOCKNG=DIRECT and VERSION<V7R7

Data Rate (SPEED)	CLOCKNG=INT	CLOCKNG=DIRECT
600	■	■
1200	■	■

Table 6-14 (Page 2 of 2). Displayed SPEED Values for 3746 Model 900 when CLOCKNG=INT or CLOCKNG=DIRECT and VERSION<V7R7

Data Rate (SPEED)	CLOCKNG=INT	CLOCKNG=DIRECT
2400	■	■
4800	■	■
9600		■
19200		■
32000		
38400		■
55855		■
64000		■
256000		■
512000		■
1024000		■
1536000		■
2048000		■

Table 6-15. Displayed SPEED Values for 3746 Model 900 X.25 Lines When CLOCKNG=EXT and VERSION<V7R7

Displayed SPEED Value	Actual Data Rate (SPEED) Values for CLOCKNG=EXT
19200	>= 600 and <= 32000
38400	> 32000 and <= 64000
256000	> 64000 and <= 256000
512000	> 256000

Considerations

The line must be inactive before this field can be modified.

Tuning Suggestions

When you use NPM, specify SPEED to ensure that line utilization is correctly calculated. Define SPEED as the clocking rate provided by the external source.

NRZI (available starting with NCP V7R7)

YES or NO to specify whether the data terminal equipment at the end of the X.25 line must operate in non-return-to-zero change-on-ones mode (YES) or in non-return-to-zero mode (NO). Defined by the NRZI keyword on the LINE statement.

NDF Default

YES

Valid Values

- YES: Operate in non-return-to-zero modify-on-ones mode (also known as non-return-to-zero inverted).
- NO: Operate in non-return-to-zero mode.

Considerations

- The line must be inactive before this field can be modified.
- The value of NRZI must be the same at both ends of the link. Mixing of modes on the same link results in total lack of communication between stations on the link.

Tuning Suggestions

- NRZI is a configuration parameter, rather than a tuning parameter, and once set correctly, should not need to be modified.
- Set NRZI to match the attached modem:
 - Specify NRZI=YES for IBM modems.
 - Specify NRZI=NO for most non-IBM modems and all IBM 5812 and 5822 data set units.
 - If external (modem) clocking is used on the line, specify NRZI=YES unless the modem is sensitive to repeated binary one-zero patterns (for example, 10101010...). Sensitivity to this pattern can cause the modem to lose synchronism when it encounters sufficiently long sequences of this pattern in message data. If the modem is sensitive to this bit pattern, specify NRZI=NO.

Clockng (tunable starting with NCP V7R7)

Whether the modem (data set) or the communication scanner for the line provides the clocking. Defined by the CLOCKNG keyword on the LINE statement.

NDF Default

EXT

Valid Values

- DIRECT: The scanner provides clocking and propagates it to the attached DTE. The data signal received by the controller is synchronized with the controller's clock. You must use a directly attached cable.
- EXT: The modem or other external source provides clocking. You can use either a directly attached cable or a modem cable.
- INT: The scanner provides clocking but does not propagate it to the attached DTE. The scanner synchronizes the received data signal; a different clock is used at each end of a link. You can use either a directly attached cable (no modem) or a modem cable.

Considerations

- The line must be inactive before this field can be modified.
- If X21SW=YES, LPDATS is not equal to NO, or LPDA2DL=YES, then Clockng is *not* modifiable.
- How Clockng is coded affects which values are valid on SPEED.
- If DIAL=NO and X21NTWK is not equal to NO, then only CLOCKNG=EXT is valid.
- If NEWSYNC=YES, then only CLOCKNG=EXT is valid.

Tuning Suggestions

Code Clockng appropriately for this line's configuration.

PF Keys

F1=Help

Displays online help for this panel.

F3=Return

Returns to the previous NTuneMON panel.

F5=MODIFY (starting with NCP V7R7)

Available when the operator has tuning authority and NTuneNCP is included. For more information, refer to Chapter 5, Using the NTuneNCP Tuning Feature.

Updates the NCP tuning parameter with the modified value. If the modification is not valid, the field turns reverse-video pink, and you are prompted to correct the value and resubmit it.

F6=Roll

Returns to the NetView command line without exiting NTuneMON. To return to NTuneMON from the NetView program, press F6=ROLL or enter **ATUNEMON** on the NetView command line.

F10=Hex

Displays the ATUDP Hexadecimal Storage Display panel, as shown on page 4-68, to show the LKB control block.

Enter=More details

Displays the second part of the line details, as shown under "ATUXS X.25 MCH Physical Line Details Page 2 Panel" on page 4-362.

F11=Virtual Circuit List

Displays the ATUXV X.25 Virtual Circuit List, as shown on page 4-366, for the selected MCH.

F12=Refresh

Refreshes the information on this panel.

PA1=Exit

Exits NTuneMON.

PA2=Log

Saves the information on this panel to the NetView log.

Chapter 7. Procedure for Adding SDLC Lines

Overview of Defining, Enabling, and Updating SDLC Peripheral Lines	7-3
SDLC Line Types	7-3
Defining Spare Lines	7-5
Enabling a Spare SDLC Line	7-5
Defining Redefinable Lines	7-6
Disabling a Redefinable SDLC Line	7-6
Keywords Used for SDLC Peripheral Lines	7-6
Important Restrictions for Spare and Redefinable Lines	7-8
VTAM Support for Spare Lines	7-9

The following topics are discussed in this chapter:

- Overview of defining, enabling, disabling, and updating SDLC peripheral lines
- SDLC line types
- Defining spare lines
- Enabling a spare SDLC line
- Defining redefinable lines
- Disabling a redefinable SDLC line
- Keywords used for SDLC peripheral lines
- Important restrictions for spare and redefinable lines
- VTAM support for spare lines

Overview of Defining, Enabling, and Updating SDLC Peripheral Lines

This procedure enables you to code spare lines in your NCP generation definition for physical line addresses for which no physical line is actually attached. Until you decide to start actually using a spare line, it will not be activated.

Note: This procedure is only supported for SDLC peripheral lines on TSS or HPTSS adapters.

Without interrupting NCP and before activating the line, you can use NTuneMON with NTuneNCP to update many of the line parameters in NCP storage to match the characteristics of the physical line which is actually being installed.

As long as a line is inactive, many of the line parameters are modifiable, even for lines which are not spare lines.

With this procedure you can:

- Define a spare line
- Physically add a line and activate it while the NCP is up and running, without having to redefine and reload the NCP
- Physically deactivate and delete a line while the NCP is up and running, without having to redefine and reload the NCP
- Convert an existing line to a spare line
- Update additional line parameters on existing lines

Notes:

1. It is strongly recommended that multiple users not attempt to update the same line concurrently.
2. As with any other NTuneMON parameters, all the updates are lost when the NCP is reloaded, unless the NCP has been regenerated to build a new load module with the changes.

SDLC Line Types

SDLC lines can be classified as follows:

- Spare
- Redefinable (Redef)
- Non-Redefinable (Non-Redef)

Spare Lines

A spare line is a line that is not currently in use and that cannot be activated.

A spare line could be a line that you defined in the generation definition for later use, even though initially there was not a line physically attached to that physical line address in the communication controller.

Conversely, a spare line could be a line which was initially attached to a particular physical line address in the NCP and which has since been removed.

A spare line could also be a line which is currently physically attached to the NCP, but for some reason, you decided to not let be activated.

NCP will reject any ACTLINK requests received for spare lines.

All spare lines were defined as USE=SPARE or as USE=REDEF on the LINE definition statement of the generation definition. If USE=SPARE was coded, the line is a spare line and the mode of operation is assumed to be NCP, not EP. For more information, refer to the USE keyword on the LINE definition statement in the NCP, SSP, and EP Resource Definition Reference.

Note: VTAM V4R2 with appropriate maintenance will never activate spare lines. Other releases of VTAM may attempt to activate spare lines, but NCP will reject the activation requests.

Redefinable Lines

A redefinable line is a line which is currently in-use, but has the capability of being changed to a spare line.

Like a spare line, a redefinable line could be a line which the user defined in the generation definition for later use which is now being used. Conversely, it could be a line which was initially physically present, but for which the user wanted the capability of physically removing later.

NCP will accept ACTLINK requests received for redefinable lines.

All redefinable lines were defined as USE=SPARE or as USE=REDEF on the LINE definition statement of the generation definition. If USE=REDEF was coded, the line is a redefinable line and the mode of operation is assumed to be NCP, not EP. For more information, refer to the USE keyword on the LINE definition statement in the NCP, SSP, and EP Resource Definition Reference.

Non-Redefinable Lines

A non-redefinable line is a line which is currently in-use, and which does not have the capability of being changed to a spare line or redefinable line.

NCP will accept ACTLINK requests received for non-redefinable lines.

Prior to NCP V7R2, all lines were non-redefinable. There was nothing in the NCP generation definition which could be coded to prevent the line from being activated once the NCP was up.

A non-redefinable line cannot be converted to either a spare or redefinable line.

All non-redefinable lines were defined as USE=NCP or USE=EP in the generation definition. If either USE=NCP or USE=EP is coded, the line is non-redefinable. USE=NCP is the default.

Note: NTuneMON does not display EP lines.

For more information, refer to the USE keyword on the LINE definition statement in the *NCP, SSP, and EP Resource Definition Reference*.

Defining Spare Lines

Note: Because a spare line requires the same amount of NCP storage as any other line, NCP storage is wasted if spare lines are coded and never actually used.

To define a spare line in your NCP generation definition, code USE=SPARE on the LINE definition statement. Code a spare line for each specific line address for which you wish to have the capability of later adding a physical line. The line must be the only line defined under its GROUP definition statement.

Though many line parameters will be modifiable, you still need to be sure the other parameters are correctly specified in the generation definition.

If any attempt is made to activate a spare line, it will be rejected. NCP will fail activation attempts with sense data XX'0801002A', meaning:

RESOURCE NOT AVAILABLE: NOT VALID TO ACTIVATE A SPARE LINE.

When you are ready to use a spare line, use NTuneMON with NTuneNCP to activate the line.

Notes:

1. Whether or not a particular VTAM will activate a particular line depends upon the NetView span of control you set.
2. VTAM V4R2 with appropriate maintenance will never activate spare lines. Other releases of VTAM may attempt to activate spare lines, but NCP will reject the activation request.

Enabling a Spare SDLC Line

Following are steps for enabling a spare SDLC line:

1. Define a spare line in the NCP generation for an empty physical line address.
2. Load and activate the NCP.

Note: VTAM V4R2 with appropriate maintenance will never activate spare lines. Other releases of VTAM may attempt to activate spare line, but NCP will reject the activation request.

3. At a later time, attach a physical line to this empty physical line address.
4. Update various line parameters, if needed, to match the actual line.
5. Change the line from a spare line to a redefinable line.
6. Activate the line.

Notes:

1. NTuneMON with NTuneNCP can be used to do the last three steps at once. See the ATUSP1 SDLC Peripheral Line Parameters Page 1 panel as shown on page 6-122 and the ATUSP2 SDLC Peripheral Line Parameters Page 2 panel, as shown on page 6-134, for details.
2. Whether or not a particular VTAM can activate a particular line depends upon the NetView span of control you set.

Defining Redefinable Lines

To define a line as redefinable (REDEF) in your generation definition, it must be the only line defined under its GROUP. Code USE=REDEF on the LINE definition statement. Code USE=REDEF on any lines which you may ever want to convert to spare lines.

Note: The advantage of initially coding all your lines as REDEF is that the lines could then be changed to spare lines if necessary.

NCP and VTAM treat redefinable lines as normal lines.

Disabling a Redefinable SDLC Line

If you decide to convert a redefinable line to a spare line, use NTuneMON with NTuneNCP to:

- Deactivate the line and mark it to indicate it is a spare line. See the ATUSP1 SDLC Peripheral Line Parameters Page 1 panel, as shown on page 6-122, for details.

Note: Whether or not a particular VTAM can deactivate a particular line depends upon the NetView span of control you set.

- From this point on, as long as NCP is not reloaded, or the line has not been converted to a redefinable line, the line will be a spare line for which NCP will fail activation attempts with sense data of X'0801002A', meaning:

RESOURCE NOT AVAILABLE: NOT VALID TO ACTIVATE A SPARE LINE.

Notes:

1. VTAM V4R2 with appropriate maintenance will never activate spare lines. Other releases of VTAM may attempt to activate spare lines, but NCP will reject the activation request.
2. It is strongly recommended that multiple users not attempt to update the same line concurrently.

Keywords Used for SDLC Peripheral Lines

The characteristics of a line are defined to NCP mainly by NDF keywords on the GROUP and LINE definition statements. For the purposes of this procedure, the keywords have been classified as follows:

- Performance and tuning keywords
- Error recovery processing (ERP) keywords
- Configuration keywords

Performance and Tuning Keywords

The following performance and tuning keywords are modifiable with NTuneMON and NTuneNCP:

- HDXSP
- LSPRI
- PAUSE
- SERVLIM

See the ATUSP2 SDLC Peripheral Line Parameters Page 2 panel, as shown on page 6-134, for details.

Error Recovery Processing (ERP) Keywords

The following Error recovery processing (ERP) keywords are modifiable with NTuneMON and NTuneNCP:

- ACTIVTO
- ETRATIO
- REDIAL
- REPLYTO
- RETRYTO
- RETRIES
- RNRLIMIT
- SRETRY
- TEXTTO
- XMITDLY

See the ATUSP2 SDLC Peripheral Line Parameters Page 2 panel, as shown on page 6-134, for details.

Configuration Keywords

The following Configuration keywords are modifiable with NTuneMON and NTuneNCP:

- ANSTONE
- CCLID
- CLOCKNG
- DATRATE
- DUPLEX
- HISPEED
- NEWSYNC
- NRZI
- RING
- SPEED
- TRANSFR
- X21NTWK

See the ATUSP1 SDLC Peripheral Line Parameters Page 1 panel, as shown on page 6-122, for details.

Important Restrictions for Spare and Redefinable Lines

Spare and redefinable lines:

- Must be SDLC peripheral lines.
- Must be on either TSS or HPTSS adapters.
- Cannot support programmed resources.
- Must be NCP lines; EP is not valid.

For spare and redefinable lines, the following are some of the important characteristics of the line that are set by the generation definition and cannot be changed later:

- The particular physical address on a particular adapter. Each physical line address in the NCP which you may wish to use in the future requires its own spare line definition.
- Whether NCP is to use this line as half-duplex or duplex mode. In other words, FULL or HALF was specified on the ADDRESS keyword on the LINE definition statement.
- The name of the line.
- Whether the line is switched or leased.
- If the line is switched, whether or not it is an X.21 switched line.
- Whether the line is primary, secondary, or negotiates its role.
- Whether NPM collection is supported on the line.
- Whether an autocal modem is going to be attached to the line and whether that modem is an ACU, an LPDA2,¹ or a V25BIS modem.
- Whether there is a channelized modem attached to the line and how it is configured.
- The maximum number of PUs the line can support.

PU's Under Spare and Redefinable Lines

The capability of updating keywords coded for PUs is not being enhanced or restricted via the procedure for adding SDLC lines. PU parameters for PUs under spare or redefinable lines have the same flexibility as those for PUs under non-redefinable lines.

For switched PUs, some PU parameters can be updated via the VTAM switched major node. For leased PUs, dynamic reconfiguration (DR) can add PUs and update PU parameters.

Also, NTuneMON with NTuneNCP can be used to update some PU parameters. See the ATUSD SDLC Station Details panel, as shown on page 6-113, for details.

Note: You must code at least one PU on a spare line. Additional PUs can then be DR-added provided the values specified for MAXPU on the LINE definition statement and MAXLIST on the SERVICE definition statement are large enough.

¹ Some aspects of the LPDA2 support can already be modified by the existing Set-link Attributes function.

VTAM Support for Spare Lines

VTAM V4R2 with appropriate maintenance can be used to:

- Display NCP lines and the current use of the line from VTAM's perspective.
- Modify the use of an NCP line from VTAM's perspective.

See *VTAM Operation* for details.

VTAM DISPLAY Command

The VTAM DISPLAY command can be issued with:

- USE=SPARE to display information about only spare lines
- USE=DEFINED to display information about only defined lines. VTAM considers both redefinable and non-redefinable lines to be defined.

When the VTAM DISPLAY command is issued for a particular NCP line, the resulting messages will indicate the current use of the line from VTAM's perspective.

See *VTAM Operation* for details.

VTAM MODIFY Command

The VTAM MODIFY command can be issued with:

- USE=SPARE to change a redefinable line to a spare line, from VTAM's perspective.
- USE=DEFINED to change a spare line to a redefinable line from VTAM's perspective. VTAM treats redefinable lines as normal lines.

See *VTAM Operation* for details.

Note: You can cause NTuneMON to issue the VTAM MODIFY command by modifying VTAM USE on the ATUSP1 SDLC Peripheral Line Parameters Page 1 panel. See VTAM USE on the ATUSP1 SDLC Peripheral Line Parameters Page 1 panel, as shown on page 6-122, for details.

Synchronization Between VTAM and NCP

It is possible for a line to currently be spare from NCP's perspective, but redefinable from VTAM's perspective, or the other way around. This could happen under the following conditions:

- You deliberately issued the VTAM MODIFY command to force the line type to be different in VTAM and NCP.
- The NCP has multiple owning VTAMs. NTuneMON with NTune NCP was used to update NCP USE and VTAM USE from one VTAM, but VTAM USE was not updated in the other VTAMs.

The following problems can occur if NCP and VTAM are out-of-synchronization with respect to USE:

- If VTAM views the line as spare, it will not activate the line even if, from NCP's perspective, the line is redefinable and should be activated.

Adding SDLC Lines

- If VTAM views the line as defined, redefinable or non-redefinable, VTAM will attempt to activate the line (if it is in VTAM's span of control), even if from NCP's perspective, the line is spare and should not be activated. In this instance, NCP will reject the activation with sense data of X'0801002A', meaning:

RESOURCE NOT AVAILABLE: NOT VALID TO ACTIVATE A SPARE LINE

Chapter 8. NTuneMON Alerts

Activating Alerts	8-3
Viewing NTuneMON Alerts	8-3
General NTuneMON Alert	8-3
NTuneMON Control Block Pool Alert	8-4
NTuneMON Generic Alerts Details	8-5

This chapter discusses NTuneMON general, control block pool, and generic alert details.

Activating Alerts

There are two ways to activate alerts:

- In your startup command. See “NTuneMON Command Options” on page 2-13 for more information.
- If alerts are not being issued, enter GENALERT or ALERT from the command line of any panel while NTuneMON is running.

Viewing NTuneMON Alerts

You can view NTuneMON alerts if the generic alert function is active. See “GENALERT Option” on page 2-17 for more information. If the generic alert function is active, issue the following NetView command from the command line:

```
NPDA
```

If NPDA (network problem determination aid/application) is running, you can go to that panel to see NTuneMON alerts. For more information, see *TME 10 NetView for OS/390 User's Guide*.

General NTuneMON Alert

Alert Condition: The user-adjustable NTuneMON alert threshold has been reached for a particular control block pool.

Table 8-1. General NTuneMON Alert

Alert ID Number		X'37C5xxxx' where “xxxx” depends on which resource the alert is being sent for.
Alert Type	X'0A'	NTFY (from GENALERT command).
Alert Description	X'5002'	Resource nearing capacity: It is still usable, but it threatens to become unusable unless corrective action is taken.
Probable Causes	X'1057'	Resource limit reached
User Causes	X'4000'	Performance Degraded
Install Causes	X'17C0'	Threshold value set too low
Failure Causes	X'4000'	Performance Degraded
Actions	X'150F'	Check threshold limit and change if set too low
Additional SVs	X'10' SV	Product Set ID
	X'31' SV	Self-defining Text Message

Notes:

1. The product set identifier which is included in the SV10 is the product set identifier of the NCP for which NTuneMON is generating the Generic Alert, not NTuneMON's own product set identifier.
2. The text that is included in the SV31 depends on which resource the Alert is being issued for. The text describes in detail which resource was having problems. It might also list the generation parameters associated with the resource.

NTuneMON Control Block Pool Alert

Alert Condition: The user adjustable NTuneMON alert threshold has been reached for a particular control block pool.

Table 8-2. NTuneMON Control Block Pool Alert

Alert ID Number		X'37C5xxxx' where "xxxx" depends on which resource the alert is being sent for.
Alert Type	X'0A'	NTFY (default from GENALERT command).
Alert Description	X'5002'	Resource nearing capacity: A resource is approaching its capacity; it is still usable, but it threatens to become unusable unless corrective action is taken.
Probable Causes	X'1057'	Resource limit reached
	X'8001'	Storage Configuration
User Causes	X'4000'	Performance Degraded
Install Causes	X'17C0'	Threshold value set too low
	X'8029'	Not enough memory in control block memory pool
Failure Causes	X'4000'	Performance Degraded
Actions	X'150F'	Check threshold limit and change if set too low
	X'1029'	Increase size of control block memory pool
Additional SVs	X'10' SV	Product Set ID
	X'31' SV	Self-defining Text Message

Notes:

1. The product set identifier which is included in the SV10 is the product set identifier of the NCP for which NTuneMON is generating the Generic Alert, not NTuneMON's own product set identifier.
2. The text which is included in the SV31 depends on which resource the Alert is being issued for. The text describes in detail which resource was having problems. It might also list the generation parameters associated with the resource.

NTuneMON Generic Alerts Details

The following table lists generic alerts issued by NTuneMON when the generic alert function as described is active. Within the table, the following applies:

Notes:

1. **Reference** refers to the type of alert being issued and the pool or counter that has exceeded the current threshold values.
2. **Keyword** is the most likely parameter that can affect this failure, but may not be the only variable that can affect the counter or pool value.
3. **Statement** is the definition statement in which the keyword can be found.

Table 8-3 (Page 1 of 2). Generic Alerts

Alert No.	Reference ¹	Keyword ²	Statement ³
37C50001	HSCBS	HSBPOOL	BUILD
37C50002	BPOOL		
37C50003	BUFFERS	MEMSIZE	BUILD
37C50004	NNTS	NAMTAB	BUILD
37C50005	NUMHSAS	NUMHSAS	BUILD, NETWORK
37C50007	GWNAU	NUMADDR	GWNAU
37C50008	LUDRPOOL	NUM-ILU TYP1,TYP2	LUDRPOOL
37C50009	LNB POOL	AUXADDR	BUILD
37C50010	LND POOL	NUM-TYP1 TYP2	LUDRPOOL
37C50011	NSC POOL	GWSESAC, SESSACC	BUILD
37C50012	BSB POOL	ADDSESS, NUMILU	BUILD, LUDRPOOL
37C50013	LTX POOL	NUMTYP1	LUDRPOOL
37C50014	NSX POOL	GWSEACC, SESSACC	BUILD
37C50015	IPPOOL	IPPOOL	BUILD
37C50016	TR LINE	AUTOGEN	GROUP
37C50017	PUDRS	NUMBER	PUDRPOOL
37C50018	LUX	BACKUP	BUILD
37C50019	VVTS	VRPOOL	BUILD
37C50020	NSB	FRSEDRPU	PUDRPOOL
37C50021	RVT		
37C50022	TR LLB	PHYPORT PHYSRSC	GROUP
37C50023	FR LLB	PHYSRSC	GROUP
37C50024	FCT	VRPOOL	BUILD
37C50025	NVT	COPIES	NETWORK
37C50026	NQE	MAXCOLL	NPA LU
37C50027	SNP	MAXSSCP	BUILD

Alerts

Table 8-3 (Page 2 of 2). Generic Alerts

Alert No.	Reference ¹	Keyword ²	Statement ³
37C50028	HRE	NUMROUTE	IPOWNER
37C50029	NRE	NUMROUTE	IPOWNER
37C50031	SRE	NUMROUTE	IPOWNER
37C50032	DYNPOOL	DYNPOOL	BUILD
37C50033	NET GWNAU	NUMADDR	
37C50034	TGBS	TGBXTRA	BUILD, NETWORK
37C50035	TRTS	TGBXTRA	BUILD, NETWORK
37C50036	VRBS	VRPOOL	BUILD
37C50037	CHANNEL TGS		
37C50038	LINK TGS		
37C50039	HELLO	MAXHELLO	IPOWNER
37C50040	ODLC FR	PHYSRSC	GROUP
37C50041	LAE	NUMDRIF	IPOWNER
37C50042	RIB	NUMDRIF	IPOWNER
37C50043	ENI	NUMDRIF	IPOWNER
37C50044	CRX	FRSEDRPU, FRDRCNT	PUDRPOOL
37C50045	NQ2	MAXCOLL	LU
37C50047	ISDN PER		
37C50048	ISDN SUBAREA		
37C50049	LXE		
37C50118	ODLC LAN	PHYSRSC, PHYPORT	GROUP
37C50119	NQX	MAXTP	NPA LU

Chapter 9. NTuneMON Messages

This chapter describes:

- NTuneMON information and error messages. These messages are displayed on the command lines of your NTuneMON panels.
- NTuneMON display messages (starting on page 9-14). These messages are displayed on the NetView screen or saved in the NetView log.

Information and Error Messages

ATUM000 MESSAGE ID *nnn* IS UNDEFINED TO NTuneMON

Explanation: Message ID *nnn* was not found in the NTuneMON message table.

User Response: Notify your IBM service representative for assistance.

ATUM001 NTuneMON TYPE=*aaa* NCP=*nnn* OUTPUT=LINE ...

Explanation: This is a confirmation message echoing the options for OUTPUT=LINE or OUTPUT=LOG. These options are not displayed if they are the same as the defaults.

User Response: No response is necessary.

ATUM003 NTUNEMON ENDED *rrr*

Explanation: NTuneMON ended the CLIST.

rrr can be one of the following:

- INVALID INPUT
- An issuing response from D NET,MAJNODES or D NET,ID=line
- Operator GO command
- Error encountered on wait
- Unknown error on wait

User Response: Your response is determined by the value of *rrr*.

- If INVALID INPUT, correct the command or option format.
See "Starting NTuneMON" on page 2-12 for help with NTuneMON commands and options.

- If Issuing response from D NET,MAJNODES or D NET,ID=line, verify that messages are not suppressed by NetView automation.
- If the GO command, an error encountered on wait, or an unknown error on wait, no response is necessary.

ATUM004 NTUNEMON ENDED NO ACTIVE NCPs WERE FOUND TO PROCESS

Explanation: NTuneMON could not locate active NCPs and ended the CLIST.

Note: The NCP must be Version 4, 5, 6, or 7.

User Response: Do one of the following:

- Verify that the NCP has been activated by this VTAM host.
- If error response, verify that STORDSP is coded on the NCP SYSCNTRL statement.
- Verify the NCPs responding to the VTAM command D NET,NCPSTOR,ID=ncp.
- Verify that messages are not suppressed by NetView automation.
- Issue RESET=YES to clear NetView global variables.
- Restart NTuneMON without the FAST option. If you specified the FAST option, the NCP might not be monitored by NTuneMON. See "FAST Option" on page 2-17 for more information.

ATUM005 NTUNEMON ENDED NCPs DID NOT RESPOND WITHIN *nnn* SECONDS

Explanation: NCPs did not respond within *nnn* seconds of NCPSTORs.

User Response: Do one of the following:

- Follow the instructions in message ATUM011, which may be issued. It instructs you to enter the VTAM command D NET,NCPSTOR,ID=ncp,ADDR=0 and see if any NCPs respond.
- Verify that messages are not suppressed by NetView automation.
- Issue RESET=YES to clear NetView global variables.
- Issue DEBUG=YES or DEBUG=LOG to see if the NCP responds.

ATUM006 ACTIVE NCP LIST SAVED *ttt* UPDATE WITH FAST=NO

Explanation: NTuneMON is using a list of NCPs that were active at *ttt* time.

NTuneMON can skip the D NET, MAJNODES command for performance if FAST=YES or FAST=AUTO (default) and if more than 500 major nodes are found.

If a new NCP is now active that was not active at *ttt* time, NTuneMON does not locate that NCP.

User Response: Reissue NTuneMON with FAST=NO to view the new NCPs and save a new list.

ATUM008 NCP *nnn* HAS BEEN REGENNED, OLD DATE = *ddd ttt*

Explanation: NTuneMON has detected that the NCP has been reloaded, where *ddd* and *ttt* are the last date and time of regeneration. NTuneMON NetView global variables are reset.

User Response: Because the user thresholds have been reset, you might want to redefine them.

ATUM009 NTUNEMON DISPLAYING *ggg* GWNAUs FOR NETWORK *bbb* NCP *nnn*

Explanation: The variable fields in the message text mean:

Variable	Meaning
ggg	The number of GWNAUs
bbb	The network ID
nnn	The name of the NCP

User Response: You can issue the NetView CANCEL command to stop the analysis.

ATUM010 NTUNEMON *aaa* ANALYSIS MAY TAKE SOME TIME, PLEASE WAIT

Explanation: This analysis may take a long time to process and use a significant amount of NetView storage and CPU cycles. *aaa* can be GWNAUs or SDLC LINES

User Response: You can issue the NetView CANCEL command to stop the analysis.

ATUM011 ISSUE D NET,NCPSTOR,ID=*ncp*,ADDR=0 AND SEE IF THE NCP ANSWERS

Explanation: This is the recommended response action for you to take after receiving message ATUM005.

User Response: For more information, see message ATUM005.

ATUM012 NTUNEMON DISPLAYING *mmm* ARP ENTRIES FOR NCP *nnn* PLEASE WAIT

Explanation: TYPE=ARP causes NTuneMON to analyze *mmm* number of ARP entries. This analysis might take a long time to process and use a significant amount of NetView storage and CPU cycles.

User Response: You can issue the NetView CANCEL command to stop the analysis.

ATUM013 COPY TO NETVIEW LOG COMPLETE

Explanation: The PA2=LOG key was pressed.

User Response: To view the output, browse or print the NetView log.

ATUM014 *ccc* IS IGNORED NTUNEMON CONTINUES

Explanation: NTuneMON option *ccc*= was issued and conflicts with TYPE=.

User Response: Check the format of the NTuneMON option.

See "Starting NTuneMON" on page 2-12 for help with NTuneMON options.

ATUM015 *aaa* USER THRESHOLD HAS BEEN CHANGED to *bbb*

Explanation: The user-defined threshold *aaa* was changed by the operator. *bbb* is the new threshold value. The updated threshold is saved to NetView global variables.

User Response: You can reset the default again by using the RESET=YES option.

ATUM016 DEFAULT VIEWS HAVE CHANGED

Explanation: Token-Ring default views have been changed on the ATUTC Token-Ring Adapter List panel.

User Response: No response is necessary.

ATUM017 PRESS F12 TO SEE TRAFFIC or POLLING RATES

Explanation: NTuneMON needs at least one refresh to calculate send and receive traffic rates. The frequency at which you refresh the panel determines the accuracy of the average traffic rates. If a long time passes between refreshes and the counts wrap more than once, the traffic rates may be inaccurate.

User Response: No response is necessary.

ATUM018 *** UTILIZATION RECORDING HAS STOPPED, SEE HELP FOR EXPLANATION *******

Explanation: The performance histogram stops 29 hours after the NCP is loaded.

User Response: No response is necessary.

ATUM019 BOTTOM REACHED

Explanation: The F8=FORWARD key was pressed and the bottom of the panel has been reached.

User Response: No response is necessary.

ATUM020 NO TG ANALYSIS PERFORMED, MAXIMUM TG COUNT EXCEEDED STOP COUNT

Explanation: The maximum number of transmission groups that the ATUSS Summary Status panel can perform transmission group analysis on has been exceeded. This count is defined by the STOP count, which defaults to 40. This is used to improve the overall performance of the ATUSS Summary Status panel when there is a large number of transmission groups defined.

User Response: Reset the STOP count to one more than the maximum number of TGs defined so that both a TG and a virtual route analysis can be viewed on the ATUSS Summary Status panel at the same time. The TG analysis can also be viewed on the ATUTG Transmission Group panel.

ATUM021 TOP OF PAGE

Explanation: The F7=BACKWARD key was pressed and the top of the panel has been reached.

User Response: No response is necessary.

ATUM022 PF keys have been set to selection number *n*

Explanation: The F11=ALT-PFKs key has been pressed, and the values of the PF keys have been reset.

User Response: No response is necessary.

ATUM023 NCPSTOR FOR *n* ENDED. NCP DID NOT RESPOND WITHIN *n* SECONDS. ONE RETRY WILL BE ATTEMPTED.

Explanation: The identified NCP did not respond within the timeout value of *n* seconds.

User Response: Verify that the NCP is active and available.

ATUM024 THE TUNING FEATURE OF NTuneMON IS NOT INSTALLED

Explanation: For NTuneMON V2R1 or later, you must have the NTuneMON tuning feature, NTuneNCP, installed in your NCP in order to tune resources.

User Response: Install the NTuneMON tuning feature, NTuneNCP.

ATUM025 Destination NCP *puname* not found, Search now using *newname*

Explanation: The PUNAME keyword on the BUILD statement was used in an unsuccessful attempt to find the destination NCP for the ATUML panel display. Another attempt will be made using the NEWNAME keyword on the BUILD statement.

User Response: No response is necessary.

ATUM100 *nnn* IS NOT A REACHABLE OR SUPPORTED NCP

Explanation: NTuneMON did not receive a valid NCP response from NCP *nnn*.

Note: The NCP must be Version 4, 5, 6, or 7.

User Response: Do one of the following:

- Verify that the NCP has been activated by this VTAM host.
 - If error response, verify that STORDSP is coded on the NCP SYSCNTRL statement.
 - Verify the NCPs responding to the VTAM command D NET,NCPSTOR,ID=ncp.
 - Verify that messages are not suppressed by NetView automation.
 - Issue RESET=YES to clear NetView global variables.
 - Issue DEBUG=YES or DEBUG=LOG.
-

ATUM101 ERROR NCP NAME *nnn* IS INVALID

Explanation: NCP *nnn* is not a valid NCP name.

User Response: Issue D NET,ID=ncp to verify that this is a valid NCP.

ATUM102 NO NCP SPECIFIED

Explanation: A fast-path command was issued at the NTuneMON command line without a specified NCP name. The NCP name is required when issuing fast-path commands from the following:

- ATUNP NCP Selection panel
- ATUNW NCP Wide Selection panel
- ATUCD CDS NCP Selection panel

User Response: Enter the fast-path command and the NCP name, separated by at least one space.

ATUM103 NO ACTIVE NCPs WERE FOUND, MUST BE NATIVE NETWORK

Explanation: NTuneMON did not receive a valid response from any NCP.

Note: The NCP must be Version 4, 5, 6, or 7.

User Response: Do one of the following:

- Verify that the NCP has been activated by this VTAM host.
- If error response, verify that STORDSP is coded on the NCP SYSCNTRL statement.
- Verify the NCPs responding to the VTAM command D NET,NCPSTOR,ID=ncp.
- Verify that messages are not suppressed by NetView automation.
- Issue RESET=YES to clear NetView global variables.
- Issue DEBUG=YES or DEBUG=LOG.

If you specified the FAST option, the NCP may not be included in the list to process. See “FAST Option” on page 2-17 for more information.

ATUM110 TOKEN-RING VIEW aa IS NOT VALID ENTER MAC IDBLK SUB CPNAME LINE

Explanation: The default Token-Ring view *aa* is not valid. *aa* is the address entered.

User Response: Enter one of the following valid values:

- MAC
- IDBLK
- SUB
- CPNAME
- LINE

ATUM111 SCOPE aaa IS NOT VALID

Explanation: SCOPE=*aaa* is not a valid entry for this TYPE=option.

User Response: Correct the option format.

See “Starting NTuneMON” on page 2-12 for help with NTuneMON options.

ATUM112 aaa nnn IS NOT VALID

Explanation: An analysis of *aaa* for *nnn* was not possible.

aaa can be one of the following:

- An NCP name, NETID, or an address
NTuneMON did not find anything to analyze in the requested NCP, network, or address.

- A command or option
NTuneMON detected a command or option syntax that is not valid.

nnn can be an NCP name, NETID, Token-Ring TIC, or a station, frame-relay, or IP address.

User Response: Your response is determined by the value of *aaa*.

- If NCP name, NETID, or address, select another resource to be analyzed.
- If a command or option, see “Starting NTuneMON” on page 2-12 for help with NTuneMON commands and options.

ATUM113 INACTIVE VRB FOUND - SELECT NEW VRs ON VR PANEL TO VERIFY

Explanation: NTuneMON has detected a virtual route that may have been active, but is now inactive.

User Response: This is normally a transient state and should be cleared by pressing the F2 key on the ATUVR Virtual Route panel. If the problem persists, this VRB is not usable until the box is reloaded. This does not affect you unless you run out of VRBs.

Note: If you believe you are running out of VRBs, notify your IBM service representative for assistance.

ATUM114 ERROR CURSOR IS NOT ON A VALID aaa

Explanation: The cursor was not placed under a valid *aaa* to perform the requested function. *aaa* can be one of the following:

- Token-Ring adapter
- TIC
- Station
- Ethernet-type LAN adapter
- Network

User Response: Position the cursor under the correct resource and reissue the command.

ATUM115 LINE /// IS NOT OWNED BY THIS HOST - DISPLAY FROM OWNING HOST

Explanation: NTuneMON tried to display the physical unit for a Token-Ring logical line. This display succeeds only if issued from the VTAM host that owns the line. In addition, this VTAM must be an owner of the NCP.

User Response: Issue the command from NTuneMON running on the VTAM host that owns the Token-Ring logical lines and the NCP.

ATUM116 LINE *lll* IS NOT DEFINED TO NCP *nnn*

Explanation: A line address was specified that was not defined to this NCP by the ADDRESS keyword on the LINE definition statement.

User Response: Specify a different line address.

ATUM117 *aaa* NOT AVAILABLE FOR *bbb*

Explanation: *aaa* and *bbb* depend on the information entered. The option available is not available for the type of resource selected.

User Response: Your response is determined by the value of *aaa*.

- If NCP name, NETID, or address, select another resource to be analyzed.
 - If a command or option, see “Starting NTuneMON” on page 2-12 for help with NTuneMON commands and options.
-

ATUM118 *aaa* USER THRESHOLD *bbb* IS NOT VALID

Explanation: The user threshold entered is either out of range or a non-numeric value. The threshold must be a numeric whole number and end in %. It must be in the range 000-999.

User Response: Reenter the appropriate value. See the description of the field in the panel explanation.

ATUM119 *aaa* THE VALUE FOR *bbb* HAS BEEN SET TO *nnn*

Explanation: *aaa* depends on information entered. The value for the *aaa* NTuneMON parameter has been customized for this session.

User Response: No response required. If changes are desired, contact the system programmer that has access to NTUNELST and request changes.

ATUM201 NO *aaa* FOUND FOR *bbb*

Explanation: No *aaa* analysis could be done for *bbb* because no *aaa* could be found. *aaa* can be one of the following:

- ARP entries
- IP router statistics
- Operative and attached Ethernet-type subsystem (ESS) adapters
- Match

bbb is the NCP name or the IP address requested.

User Response: Do the following:

- Verify that the resources (ESS or Token-Ring adapters or IP) are defined to NCP.
 - Verify that the NCP is:
 - V5R4 or later releases for Token Ring
 - V6R1 or later releases for Ethernet
 - V7R1 or later releases for NTRI attached LAN
 - V6R1 or later releases for IP resources
 - V6R2 or later for frame relay
-

ATUM202 *nnn* MUST BE *aaa* FOR *bbb* ANALYSIS

Explanation: NCP *nnn* is not valid for *aaa* analysis of *bbb* because of one of the following:

- Controller is not an IBM 3745 for Scanners analysis.
- NCP is not V5R4 or later for Token-Ring analysis.
- NCP is not V4R3.1 or later for NNT analysis.
- NCP is not V6R1 or later for Ethernet-type LAN analysis or IP router statistics.
- NCP is not V7R1 or later for IP UDP router statistics.

User Response: No response is necessary.

ATUM203 NO *aaa* *bbb* FOUND FOR *nnn*

Explanation: No *aaa* analysis could be done for *bbb* because no *aaa* could be found. *aaa* and *bbb* are details of the item not found, and *nnn* is the resource that was being checked. Examples:

- *aaa* is SCOPE=, *bbb* is TYPE=TG or TYPE=VR, and *nnn* is NCP name.
- *aaa* is SNI or GWNAUs, *bbb* is Network, and *nnn* is NCP name.

User Response: Verify that SNI networks are defined in the NCP.

ATUM204 ERROR MISSING PANEL *aaa* FROM NETVIEW

Explanation: An NTuneMON panel is missing from the NetView panel library (MVS) or file (VM). *aaa* is the panel ID.

NTuneMON continues to process.

User Response: Do one of the following:

- For VM, verify that the panel has a file type of NCCFLST.
- For MVS, check the NetView panel library for the missing panel. Verify that you are pointing to the correct NetView library.

ATUM205 ERROR WITH VIEW PANEL *ppp* RC=*nnn*

Explanation: NTuneMON received error *nnn* trying to view panel *ppp*. *ppp* is the panel ID, and *nnn* is the reason code number.

User Response: Issue the TUTOR command against panel *ppp* to determine the problem.

If the problem persists, notify your IBM service representative for assistance.

ATUM206 ERROR GIVEN ETHERNET ADAPTER NOT FOUND FOR *nnn*

Explanation: Ethernet-type subsystem adapters not found for NCP *nnn*.

User Response: Check NCP generation for valid Ethernet-type subsystem statements.

ATUM207 ERROR NON-VALID NCP ADDRESS POINTER ENTERED FOR NCP *nnn*

Explanation: An NCP address that was not valid was issued from the ATUDP Hexadecimal Storage Display panel.

User Response: Either enter a valid address in the Display address field, or position the cursor on a valid address to follow.

ATUM208 ERROR *nnn* IS NOT AN ACTIVE NCP

Explanation: NTuneMON did not receive a valid response from NCP *nnn*.

Note: The NCP must be Version 4, 5, 6, or 7.

User Response: Do one of the following:

- Verify that the NCP has been activated by this VTAM host.
- If error response, verify that STORDSP is coded on the NCP SYSCNTRL statement.
- Verify the NCPs responding to the VTAM command D NET,NCPSTOR,ID=ncp.
- Verify that messages are not suppressed by NetView automation.
- Issue RESET=YES to clear NetView global variables.
- Issue DEBUG=YES or DEBUG=LOG.

ATUM209 ERROR - NCP *nnn* ADDRESS *aaa* OUT OF RANGE

Explanation: An NCP address that was not valid was issued from the ATUDP Hexadecimal Storage Display panel.

User Response: Either enter a valid address in the Display address field, or position the cursor on a valid address to follow.

ATUM210 ERROR NCP *nnn* INVALID SENSE=*sss* RECEIVED

Explanation: Sense code *sss* was received from NCP *nnn* on a D NET,NCPSTOR command.

User Response: Make sure that the NCP is valid for D NET,NCPSTOR commands. Issue the NetView SENSE command to view the sense code description.

ATUM211 Incompatibility Error, *type1* lines genned for *type2* adapter.

Explanation: Token-Ring lines were genned for an ESCP adapter, or ESCP lines were genned for a Token-Ring adapter.

User Response: Check the NCP generation for valid LINE statements.

ATUM212 IP INTERFACE ADDRESS must be SELECTED for IP DETAILS

Explanation: On the ATUIR IP Route Table Entries panel, you pressed Enter before you did one of the following:

- Placed the cursor under the row of the host, subnetwork, or network route you wanted to select.
- Typed in the destination address you wanted.

User Response: Do one of the following:

- Place the cursor under the row of the host, subnetwork, or network route you want to select and press Enter.
- Type in the destination address you want and press Enter.

ATUM213 NTuneNCP *version* is incorrect level for *function*

Explanation: The installed level of NTuneNCP cannot perform the requested function.

User Response: Install the correct level of NTuneNCP.

ATUM214 Netid = *bbb* not defined in NCP *nnn*

Explanation: The network ID that you asked NTuneMON to verify when you pressed F4 on the ATUCH or ATUCL panel is not defined in NCP *nnn*.

User Response: No response is necessary, but you can try again with a different network ID.

ATUM215 *Netid = bbb found, use modify key to change*

Explanation: The network ID that you asked NTuneMON to verify when you pressed F4 on the ATUCH or ATUCL panel has been verified.

User Response: Either press the F5 key to switch to the new network ID or press the F12 key to refresh the panel and verify a new network ID.

ATUM250 *MSGRCVDERROR nnn aaa SENSE=sss ccc*

Explanation: This message is displayed only with the DEBUG=YES or DEBUG=LOG option. The D NET,NCPSTOR command received sense code *sss* for NCP *nnn* for NCP HEX address *aaa*. *ccc* is the routine to process.

User Response: No response is necessary.

This is only used for NTuneMON problem determination. Receiving sense codes might not be a problem because this is how NTuneMON determines if this is a valid NCP. If NTuneMON receives this message after it has determined this NCP is valid, then this could be a problem in NTuneMON's logic. Issue the NetView SENSE command to view the sense code description.

ATUM251 *aaa nnn ccc xxx sss ddd*

Explanation: This message is displayed only with the DEBUG=YES or DEBUG=LOG option.

The variable fields in the message text mean:

Variable	Meaning
aaa=MSGRCVD	NTuneMON has received a response from the NCP.
aaa=MSGOLD	NTuneMON already has the requested data. There was no need to schedule a D NET,NCPSTOR command from NCP <i>nnn</i> for address <i>sss</i> .
nnn	The NCP name.
ccc	The NTuneMON control block name.
xxx	The control block NTuneMON index.
sss	The NCP address displayed.
ddd	The first 8 bytes of the data (only on MSGRCVD).

User Response: No response is necessary.

This is used only for NTuneMON problem determination.

ATUM252 *aaa nnn ccc xxx sss ooo lll rrr*

Explanation: This message is displayed only with the DEBUG=YES or DEBUG=LOG option.

The variable fields in the message text mean:

Variable	Meaning
aaa=SCHEDCB	NTuneMON has scheduled a D NET,NCPSTOR command.
aaa=NOPSCED	NTuneMON is ignoring the request to display this address because this control block is not needed for this function. The control block does not appear in the NTuneMON function mask (D.NCP.MASK).
aaa=DUPSCED	NTuneMON does not schedule this request for NCP storage because a request is already outstanding for the same address <i>aaa</i> . NCPSTOR command from NCP <i>nnn</i> for address <i>sss</i> offset <i>ooo</i> .
nnn	The NCP name.
ccc	The NTuneMON control block name.
xxx	The control block NTuneMON index.
sss	The NCP address displayed.
ooo	The offset into the address <i>sss</i> displayed (optional). Defaults to one byte for pointer displays.
lll	The length of the display (optional). Defaults to 3.
rrr	The function to return to when the data arrives (optional). Defaults to cccRETURN.

User Response: No response is necessary.

This is used only for NTuneMON problem determination.

ATUM253 *aaa nnn xxx ccc hhh*

Explanation: This message is displayed only with the DEBUG=YES or DEBUG=LOG option. This message appears when NTuneMON sets a global variable.

The variable fields in the message text mean:

Variable	Meaning
aaa=PUTC	Save common global variable.
aaa=PUTT	Save task global variable.
nnn	NCP or NCPMLST for saved list of NCPs from D NET,MAJNODES.
xxx	Index of NTuneMON global variable.
ccc	The value of the global variable.
hhh	Hold, do not set global variable unless it is full, or force setting of global variable.

Variable	Meaning
ATUMONCNT.nnn	The count of global variables for NCP <i>nnn</i> .
ATUMON.nnn.xxx	The global variable being set.

User Response: No response is necessary.
 This is only used for NTuneMON problem determination.

ATUM254 NTuneMON RESET GLOBALV *aaa* FOR *nnn* NOW INITIALIZING

Explanation: This message is displayed only with the DEBUG=YES or DEBUG=LOG option.

This message appears when NTuneMON resets the global variables for NCP *nnn* or NCPMLST for saved list of NCPs from D NET,MAJNODES. This is automatic if NTuneMON detects that the NCP has a new generation date or if the RESET=YES option is entered.

The variable fields in the message text mean:

Variable	Meaning
aaa=GETC	Reset common global variable.
aaa=GETT	Reset task global variable.
ATUMONCNT.nnn	Set to zero for NCP <i>nnn</i> .
ATUMON.nnn.xxx	The global variable being reset.

User Response: No response is necessary.
 This is only used for NTuneMON problem determination.

ATUM255 *aaa nnn xxx ccc*

Explanation: This message is displayed only with the DEBUG=YES or DEBUG=LOG option. This message appears when NTuneMON gets a global variable.

The variable fields in the message text mean:

Variable	Meaning
aaa=GETC	Save common global variable.
aaa=GETT	Save task global variable.
nnn	NCP or NCPMLST for saved list of NCPs from D NET,MAJNODES.
xxx	Index of NTuneMON global variable.
ccc	The value of the global variable.
ATUMONCNT.nnn	The count of global variables for NCP <i>nnn</i> .
ATUMON.nnn.xxx	The global variable being set.

User Response: No response is necessary.
 This is used only for NTuneMON problem determination.

ATUM256 GENALERT *nnn iii ttt*

Explanation: This message is displayed only with the DEBUG=YES or DEBUG=LOG option and the GENALERT=YES option. A generic alert is issued for NCP *nnn*, where *iii* is the generic alert ID, and *ttt* is the text. A generic alert is also issued if a user threshold is exceeded or a severe condition is detected.

User Response: No response is necessary.

This is used only for NTuneMON problem determination. You can issue the NetView NPDA command to view the alert.

ATUM257 NTuneMON *aaa* GLOBALV VARIABLES FOR *nnn* NOW INITIALIZING

Explanation: This message is displayed only with the DEBUG=YES or DEBUG=LOG option. This message appears when NTuneMON gets the global variables.

The variable fields in the message text mean:

Variable	Meaning
aaa=GETC	Get common global variable.
aaa=GETT	Get task global variable.
nnn	NCP or NCPMLST for saved list of NCPs from D NET,MAJNODES.
ATUMONCNT.nnn	The count of global variables for NCP <i>nnn</i> .
ATUMON.nnn.xxx	The global variable retrieved.

User Response: No response is necessary.
 This is used only for NTuneMON problem determination.

ATUM258 DEBUG=*aaa* NOW SET

Explanation: You typed DEBUG on the command line of an NTuneMON panel to toggle the debug feature on or off. DEBUG=YES indicates that the debug feature is now on. DEBUG=NO indicates that the debug feature is now off.

User Response: No response is necessary.

ATUM259 NCP=*nnn* Location=*aaa*

Explanation: This message is only displayed when the NTuneMON internal trace is running. It identifies the NCP being processed *nnn* and the current location of *aaa* in the code. These messages are written to the log. The internal trace is used to investigate NTuneMON internal problems.

User Response: Save output for IBM service personnel. Contact IBM NTuneMON support personnel.

ATUM260 PARAMETER *aaa* = *bbb*

Explanation: This message is only displayed when the NTuneMON internal trace is running. It identifies a parameter *aaa* and its contents *bbb*. These messages are written to the log. The internal trace is used to investigate NTuneMON internal problems.

User Response: Save output for IBM service personnel. Contact IBM NTuneMON support personnel.

ATUM261 INTERNAL TRACE = *aaa* NOW SET

Explanation: This message is issued only when the NTuneMON internal trace is running. *aaa* indicates the state of the trace.

User Response: If instructed by IBM support personnel to run the trace, save the log and return it to IBM.

ATUM262 INTERNAL TRACE COMMAND *aaa* NOT VALID

Explanation: *aaa* is the trace command which is not valid.

User Response: Verify the command and reenter it. If instructed by IBM support personnel to run the trace, verify the command with them.

ATUM263 GENALERT YES/NO NOW SET

Explanation: The GENALERT command, which the user issued from the NetView command line, has been executed.

User Response: No response is necessary. This is an information message to inform the user of the GENALERT status.

ATUM297 *aaa* IN-USE IS GREATER THAN 999%

LNB IN-USE IS GREATER THAN 999%

Explanation: The percentage that was calculated is greater than 999%.

User Response: No response is necessary.

ATUM298 *aaa* MAX IN-USE IS GREATER THAN 999%

Explanation: The percentage that was calculated is greater than 999%.

User Response: No response is necessary.

ATUM299 NTuneMON INTERNAL ERROR INVALID

aaa

Explanation: NTuneMON detected an internal error. *aaa* is a TYPE= option incorrectly defined in NTuneMON.

User Response: Notify your IBM service representative for assistance.

ATUM605 Unable to fastpath to ATUxx from ATUyy

Explanation: You issued a fast-path command for a panel that either:

- Does not have a fast path defined
- Has some restrictions to the use of the fast-path command

User Response: Look up Table 3-1 on page 3-4. If you have the correct version and release of NCP and the resources for the panel you want to view, you can enter a fast path from this table on any other NTuneMON panel. If a fast path is not in this table, then there are usually some restrictions to entering it or it is not a valid fast path.

ATUM613 Network ID unknown, command failed

Explanation: NTuneMON does not recognize the network ID.

User Response: When issuing the IB or IC fast-path commands from the ATUNG HSCBs and GWNAUs panel, verify that the cursor is on a network ID. When running with TYPE=GWNAUD, verify that the network entered is a valid network name or is blank for all networks.

ATUM699 *a b c d e f g h i j*

Explanation: This message is displayed only if NTuneMON is executed with *DEBUG=ACTIVE*. The message provides information necessary for diagnosing the panel-to-VTAM interface.

User Response: None.

ATUM700 NTuneMON scheduled change of *aaa bbb* from *ccc* to *ddd* Panel ATUxx, NCP *yyy*, Resource: *zzz*

Explanation: A change of an NCP parameter has been scheduled, where:

- *aaa bbb* describe the parameter
- *ccc* describes the value
- *ddd* describes what the value will be changed to
- ATUxx describes the panel being changed
- NCP *yyy* describes the NCP affected
- Resource: *zzz* describes the resource affected

User Response: See Chapter 5, “Using the NTuneNCP Tuning Feature” on page 5-1 for more information.

ATUM701 *aaa* has *nnn* changes made via TUNING

Explanation: This message displays the number of changes *nnn* made by NCP *aaa*.

User Response: If the number of changes is not what is expected, check for additional error messages.

ATUM702 OPERATOR *operator-id* HAS TUNING AUTHORITY

Explanation: The identified operator has the ability to change the tuning fields within the NCP.

Operator Response: This is an informational message. Notify your system programmer if you have no need for tuning authority.

Programmer Response: Modify the NTUNELST CLIST message. *ALL* is the default. Remove *ALL* from NTUNELST and add only those IDs that will have authority to tune NCPs.

ATUM703 OPERATOR *operator-id* HAS NO TUNING AUTHORITY

Explanation: The operator ID does not have the ability to change the tuning fields within the NCP.

Operator Response: This is an informational message. Notify your system programmer if you need tuning authority.

Programmer Response: Modify the NTUNELST CLIST message. *ALL* is the default. Remove *ALL* from NTUNELST and add only those IDs that will have authority to tune NCPs.

ATUM704 Use F2=VERIFY before F4=MODIFY,ACT or F5=MODIFY. See HELP (F1)

Explanation: You should do a verify function before using either F4 or F5.

User Response: Do one of the following:

- Go to “Verifying Tuning Changes for ATUSP1 and ATUSP2” on page 5-17 and “Submitting the Tuning Request for ATUSP1 and ATUSP2” on page 5-17 in the *NTuneMON User’s Guide* for more information.
- Press F1=HELP from the ATUSP1 SDLC Peripheral Line Parameters Page 1 panel or the ATUSP2 SDLC Peripheral Line Parameters Page 2 panel. Then, on the Main Help panel for ATUSP1 SDLC Peripheral Line Parameters Page 1 or ATUSP2 SDLC Peripheral Line Parameters Page 2, select Option 3, How To Modify NTuneNCP Tuning Fields.

ATUM705 Keyword must be REPLYTO, RETRYTO, TEXTTO or XMITDLY to Modify Timer

Explanation: You pressed F9 without selecting a timer value. To modify a timer value, you must select the REPLYTO, RETRYTO, TEXTTO, or XMITDLY fields on the ATUSP2 SDLC Peripheral Line Parameters Page 2 panel and then press F9 to go to the ATUMT Modify Timer Value panel.

User Response: For more information on how to modify these fields, see “ATUSP2 SDLC Peripheral Line Parameters Page 2 Panel” on page 6-134 and “ATUMT Modify Timer Value Panel” on page 6-97.

ATUM706 WARNING: aa for timer will be permanently changed. Accept? Y/N

Explanation: You are using the ATUMT Modify Timer Value panel to set a timer value to *aa*. After you set the value, it can be changed only by reloading the NCP. You are being asked to confirm that you want to set the timer value to *aa*.

User Response: Enter Y or YES if *aa* is correct and you want to set the timer value. Enter N or NO if you do not want to set the timer value.

ATUM707 TO FORCE DEACTIVATE LINK TYPE YES or NO, HIT PF4

Explanation: You pressed F4, which causes a forced deactivation of an SDLC link. You are being asked to confirm that you want a forced deactivation of the link.

User Response: Enter YES and press F4 if you want a forced deactivation of the link; enter NO and press F4 if you do not want a forced deactivation of the link.

ATUM708 Verification Successful

Explanation: You have pressed F2, which changes values on ATUSP1 SDLC Peripheral Line Parameters Page 1 and/or ATUSP2 SDLC Peripheral Line Parameters Page 2. The values you selected are within range and consistent.

User Response: None.

ATUM709 X IS CURRENTLY NOT MODIFIABLE

Explanation: You selected a timer value from ATUSP2 and pressed F9=MOD TIMER to modify the value. The timer value is not modifiable because:

- Your NCP is not V7R2 or later releases.
- When MODE=SEC, REPLYTO has a fixed value that must not be changed.
- When X21SW=NO, RETRYTO is not applicable.
- When MODE=SEC, TEXTTO has a fixed value that must not be changed.
- When DIAL=NO, XMITDLY is not applicable.
- Multiple lines were defined under one group.

User Response: See the ATUSP2 SDLC Peripheral Line Parameters Page 2 panel on page 6-134, for more information regarding the REPLYTO, RETRYTO, TEXTTO, and XMITDLY keywords.

**ATUM710 CHANGE ACCEPTED...CAUTION
RETRIES m * (n+1) is > 128**

Explanation: RETRIES m * (n+1) is greater than 128, which is the recommended maximum for SDLC. However, your change was accepted.

User Response: For more information, see the RETRIES keyword on the LINE definition statement in the *NCP, SSP, and EP Resource Definition Reference*.

**ATUM711 NTuneMON scheduled force reroute of
ncp-name for line-name**

Explanation: This message acknowledges the path switch that you scheduled by pressing F4 on the ATUTL panel.

User Response: Wait for a message indicating acceptance or rejection of the path switch.

**ATUM712 The Scheduler force reroute has been
accepted**

Explanation: The path switch that you scheduled by pressing F4 on the ATUTL panel has been accepted.

User Response: Wait for NetView to receive the Path Switch notification alert, then press F12 to refresh the panel. NTuneMON will then retrieve and display the subarea connection's new bridged route.

ATUM731 Invalid TUNING entry aa is bb cc dd ee

Explanation: Explanation for aa is not valid.

User Response: See Chapter 5, "Using the NTuneNCP Tuning Feature" on page 5-1 for a description of the parameters.

ATUM732 Invalid TUNING entry aa conflicts with bb

Explanation: Entry aa is not valid and conflicts with bb

User Response: See Chapter 5, "Using the NTuneNCP Tuning Feature" on page 5-1 for a description of the parameters.

ATUM733 Invalid TUNING entry a must be b c d e

Explanation: Entry for a is not valid.

User Response: See Chapter 5, "Using the NTuneNCP Tuning Feature" on page 5-1 for a description of the parameters.

**ATUM734 Invalid TUNING entry aa status must be
bb for TUNING**

Explanation: Entry cannot be tuned because of its states or current values.

User Response: See Chapter 5, "Using the NTuneNCP Tuning Feature" on page 5-1 for a description of the parameters.

**ATUM735 Invalid TUNING entry aa not numeric, out
of range, or conflicts**

Explanation: Error in tuning entry.

User Response: See Chapter 5, "Using the NTuneNCP Tuning Feature" on page 5-1 for a description of parameter.

**ATUM736 Invalid TUNING entry aa not numeric or
out of range**

Explanation: Error in tuning entry.

User Response: See Chapter 5, "Using the NTuneNCP Tuning Feature" on page 5-1 for a description of parameter.

**ATUM737 INVALID TUNING ENTRY -
MAXFRAME/MAX DLCI MISMATCH**

Explanation: You were trying to change the LMI protocol standard for ANSI to CCITT or CCITT to ANSI. The protocol standard cannot be changed because the maximum DLCI address of the current standard is not an acceptable size for the standard to which you want to switch. See "ATUFP Frame Relay Physical Line Details Page 1 Panel" on page 6-34 or "ATUTD NTRI Frame Handlers Logical Line Details Panel" on page 6-152 for more information.

User Response: The NCP may be supporting fewer DLCIs than if it had been generated with the standard to which you want to switch. For more information, see the description of the DLCI or ADDR keyword on the PU statement in the *.NCP, SSP, and EP Resource Definition Reference*

**ATUM738 Invalid tuning parameters. See LOG for
Details**

Explanation: An error was detected or an incorrect parameter value was entered. See the NetView log output for more information.

User Response: Perform the following steps:

- For more tuning information, look up the panel in Chapter 6, "Using NTuneMON Panels for Tuning" on page 6-1.
- Try the Verify or Modify again.
- If you receive this message again, save the message output and the value(s) being changed. Call IBM service.

ATUM739 Invalid tuning parameters. *www* conflicts with *xxx yyy zzz*

Explanation: The change you are trying to make to *www* conflicts with how *xxx yyy zzz* are defined.

User Response: Perform the following steps:

- For more tuning information, go to the description of the panel in Chapter 6, “Using NTuneMON Panels for Tuning” on page 6-1.
- Try the Verify or Modify again.
- If you receive this message again, save the message output and the value(s) being changed. Call IBM service.

ATUM740 *a* must be $\geq b$ or $\leq c$

Explanation: You were trying to modify a keyword on the ATUSP1 SDLC Peripheral Line Parameters Page 1 panel, the ATUSP2 SDLC Peripheral Line Parameters Page 2 panel, or the ATUMT Modify Timer Value panel. The value you specified for the keyword was not within the valid range, greater than or equal to *b* or less than or equal to *c*.

User Response: For information on the values you can specify, see one of the following:

- “ATUSP1 SDLC Peripheral Line Parameters Page 1 Panel” on page 6-122
- “ATUSP2 SDLC Peripheral Line Parameters Page 2 Panel” on page 6-134
- “ATUMT Modify Timer Value Panel” on page 6-97

ATUM741 Invalid tuning entry - *field* cannot be *modification*

Explanation: The value of the identified field cannot be changed as described by *modification*.

User Response: Correct and resubmit the modification.

ATUM742 Invalid entry - *user-response*

Explanation: The entry that was just made is not valid.

User Response: See the user response suggested by the message.

ATUM800 Internal Error encountered. Failure code = *aaa*

Explanation: An internal error has been encountered. NTuneMON has detected an unrecoverable error.

User Response: Use the following procedure to report failure to IBM:

1. Record the message and the field that you were attempting to change.

2. TAB to the command line and Enter *DEBUG:* (EOB).
3. TAB to the command line and Enter *ITRACE ON* (EOB).
4. Enter the value that caused the initial failure (F5).
5. Save the log for use by IBM support.

Notes:

1. (EOB) and (F5) mean to press the Enter or F5 key.
2. See “Return Codes” on page 5-16 for a list of failure codes and their meanings.
3. In case of failure code 000A, see messages ATUM801 and ATUM803 for additional information.

ATUM801 Change rejected. Conditions to allow *aa* to *bb* may have changed.

Explanation: The target NCP has rejected the change. The state or condition of the resource has changed from the time of displaying the panel to the time the NCP received the commands.

User Response: Use the following procedure:

1. Refresh your screen
2. Check the eligible fields for modification and ensure that desired changes are valid.
3. If you feel that NCP should allow the change, follow instructions for reporting problems to IBM as described in the user response field of message ATUM800.

ATUM802 NCP *aaa* has become unknown. Failure code = *bbb*

Explanation: The NCP being modified has failed to respond or has timed out.

User Response: Refresh your panel, observe results, and contact IBM support if the problem persists. Failure codes are as follows:

- 264 - Indicates that during the course of modifying NCP, the process timed out.
- 280 - Indicates that during the course of modifying NCP, VTAM detected the NCP has become inactive and has sent notification.

ATUM803 Tuning aborted. Check resource. Change of *aa* failed

Explanation: NCP has rejected a change because of a change in resource status. Status was correct when the panel was displayed but has become ineligible.

User Response: Use the following procedure:

1. Check the resource status.
2. Ascertain proper state for field being modified.
3. Try again. If the problem persists, follow the instructions for reporting problems to IBM as

described in the user response field of message ATUM800.

**ATUM804 NCP *aaa* UNCHANGED. VTAM AT
INCORRECT RELEASE LEVEL**

Explanation: To tune NCP, VTAM must be at the level that recognizes the required commands.

User Response: Refresh the panel to re-display the unchanged values. See Chapter 5, "Using the NTuneNCP Tuning Feature" on page 5-1 for more information.

ATUM805 Last maintenance applied was *aaa*

Explanation: This message tells you the current maintenance level (*aaa*) for NCP.

User Response: No response is required.

Display Messages

NTuneMON issues these messages to display information on NCP resources as follows:

- NTuneMON sends these messages to the NetView screen when you start NTuneMON with the OUTPUT=LINE option.
- NTuneMON sends these messages to the NetView log when you start NTuneMON with the OUTPUT=LOG option or when you press PA2=LOG in an NTuneMON panel.

The data shown is sample data only. The messages NTuneMON issues depend on:

- Your NCP release level.
- Your NTuneMON release level.
- The resources that you are using.
- The values you specify for the ADDR, HEX, NETWORK, SCOPE, SUBAREA, TGN, and TYPE options when you start NTuneMON with OUTPUT=LINE or OUTPUT=LOG. For more information, see “NTuneMON Command Options” on page 2-13.

Each set of messages is associated with a particular NTuneMON panel. For a description of the information in a set of messages, look up the associated panel in Chapter 4.

ATUM300 to ATUM304

```

ATUM300 LINE      MAC      ACTIVE      TYPE
ATUM301 ADDR     ADDRESS   LINES      T/R MXTSL   TIC STATUS
ATUM302 _____|_____||_____||_|_|_|_|_|
ATUM303 ANY      NCP30    0%         0
ATUM304 1088 400037301088 23%        4 16M 2044 ANY 2 ACTIVE
ATUM304 1089 400037451001 25%        4 4M  692 ANY 2 ACTIVE
ATUM303 ANY      NCP27    0%         0
ATUM304 1092 400037271092 0%         0 16M 2044 ANY 2 BEACONING
ATUM304 1093 400037451002 0%         0 16M 2044 ANY 2 RING RECOVERY
ATUM201 NO TOKEN-RING ADAPTERS FOUND FOR NCP40
ATUM202 NCP29 MUST BE V5R4 OR LATER FOR TOKEN-RING ANALYSIS
    
```

Explanation: NTuneMON display for TYPE=TIC or TC, or PA2=LOG output from the ATUTC Token-Ring Adapter List panel.

User Response: See “ATUTC Token-Ring Adapter List Panel” on page 4-278 for more information.

ATUM305 to ATUM309

```

ATUM305 =NCP30=====QUEUED BYTES ACTUAL/THRESHOLD
ATUM306 NETWORK | SUB |TG | LOW |MEDIUM| HIGH |TOTAL | STATE |
ATUM307 =====|=====|===|=====|=====|=====|=====|
ATUM308 USIBMT0  1  1  384  -  -  384  OPERATIVE
ATUM309                                125952 -  -  251904 CHANNEL
ATUM308 USIBMT0  61  1  0  0  0  0  OPERATIVE
ATUM309                                5000 5000 5000 20000 INN LINK
ATUM308 NETV    63  1  0  0  0  0  OPERATIVE
ATUM309                                5000 5000 5000 20000 INN LINK
    
```

Explanation: NTuneMON display for TYPE=TG or TGB, or PA2=LOG output from the ATUTG Transmission Group panel.

User Response: See “ATUTG Transmission Group Panel” on page 4-294 for more information.

ATUM310 to ATUM313

```

ATUM310 NCP30    TOKEN-RING LIST OF ACTIVE MAC  ON ADDR=ALL
ATUM311 LOGICAL LINES DISPLAYED =      8/8
ATUM312 10005A250574 10005A31DAAA 10005A8A9721 400000937061
ATUM312 400000937062 400000937063 400037452001 400067301261

ATUM310 NCP30    TOKEN-RING LIST OF ACTIVE MAC IDBLK ON ADDR=1088
ATUM311 LOGICAL LINES DISPLAYED =      8/8
ATUM313 10005A250574 05D-76181 10005A31DAAA 05D-44128
ATUM313 10005A8A9721 05D-09895 400000937061
ATUM313 400000937062                400000937063
ATUM313 400037452001                400067301261
    
```

Explanation: NTuneMON display for TYPE=MAC,IDBLK,CPNAME,LINE,SUB, or PA2=LOG output from the ATUTA Token-Ring SNA Station List panel.

User Response: See “ATUTA Token-Ring SNA Station List Panel” on page 4-273 for more information.

ATUM315 to ATUM318

```

ATUM315 NCP29===== (WINDOW SIZES)=( VR )==RCVDQ/=XMIT=====
ATUM316 NETWORK | SUB | VRTP | CUR MAX MIN | SEND/RCV | LIMIT | QUE | STATE
ATUM317 =====|=====|=====|=====|=====|=====|=====|=====
ATUM318 USIBMTO  1  0.1  4  239  1  0CA3 086F 0/9  0
ATUM318 USIBMTO  1  0.2  7  239  1  0B01 082C 0/34  0
ATUM318 USIBMTO 29  0.1  3  5  3  0D59 0000 0/11  0  INTERNL
ATUM318 RTPLSS  1  0.1  3  3  1  0768 0636 0/10  0
ATUM318 RTPLSS  1  0.2  3  3  1  04BB 04AA 0/9  0
    
```

Explanation: NTuneMON display for TYPE=VR or VRB, or PA2=LOG output from the ATUVR Virtual Route panel.

User Response: See “ATUVR Virtual Route Panel” on page 4-334 for more information.

ATUM320 to ATUM322

```

ATUM320 NCP NAME | SUB | GEN-DATE | NCPREL | NTUNEMON | SYS | CTLR | S/N |
ATUM321 =====|=====|=====|=====|=====|=====|=====|=====|
ATUM322 NCP27    27  02/10/92 V5R4  V3R6 MVS 3745410 0002779
ATUM322 NCP29    29  05/11/92 V4R3.1 V3R4 MVS 3725 0004162
ATUM322 NCP30    30  06/08/92 V5R4  V3R6 MVS 3745410 0002779
ATUM322 NCP40    40  06/08/92 V6R1  V3R7 MVS 3745410 0045410
    
```

Explanation: NTuneMON display for TYPE=GEN or NP, or PA2=LOG output from the ATUNP NCP Selection panel.

User Response: See “ATUNP NCP Selection Panel” on page 4-204 for more information.

ATUM325

```

ATUM325 VR Timer Alert Panel
ATUM699
ATUM699          (variable data)
ATUM699
:
    
```

Explanation: NTuneMON display for PA2=LOG from the ATUVT panel.

User Response: See “ATUVT VR Alert Timer Panel” on page 4-338 for more information.

ATUM340

ATUM340 Bisync Line Detailed Information

ATUM699
 ATUM699 (variable data)
 ATUM699
 ⋮

Explanation: NTuneMON display for PA2=LOG from the ATUPS panel when a bisync line is being displayed.

User Response: See “ATUPS Bisync/SS Line Details Panel” on page 4-223 for more information.

ATUM341

ATUM341 Start/Stop Line Detailed Information

ATUM699
 ATUM699 (variable data)
 ATUM699
 ⋮

Explanation: NTuneMON display for PA2=LOG from the ATUPS panel when a start-stop line is being displayed.

User Response: See “ATUPS Bisync/SS Line Details Panel” on page 4-223 for more information.

ATUM342

ATUM342 Bisync Line List

ATUM699
 ATUM699 (variable data)
 ATUM699
 ⋮

Explanation: NTuneMON display for PA2=LOG from the ATUPT panel when a bisync line is being displayed.

User Response: See “ATUPT Bisync/Start Stop Device List Panel” on page 4-227 for more information.

ATUM343

ATUM343 Start/Stop Line List

ATUM699
 ATUM699 (variable data)
 ATUM699
 ⋮

Explanation: NTuneMON display for PA2=LOG from the ATUPT panel when a start-stop line is being displayed.

User Response: See to “ATUPT Bisync/Start Stop Device List Panel” on page 4-227 for more information.

ATUM346

ATUM346 PEP Line Information Details

ATUM699
 ATUM699 (variable data)
 ATUM699
 ⋮

Explanation: NTuneMON display for PA2=Log from the ATUED panel.

User Response: See “ATUED PEP Line Details Panel” on page 4-78 for more information.

ATUM375

```

ATUM375 NCP Histogram information
ATUM699
ATUM699      (variable data)
ATUM699
:
```

Explanation: NTuneMON display for PA2=LOG output from the ATUUH panel.

User Response: See “ATUUH Cycle/Buffer Utilization History Panel” on page 4-325 for more information.

ATUM380

```

ATUM380 Detailed IP Interface Information
ATUM391 Interface Address= 172.55.1.1
ATUM391 Gateway Address= 172.59.7.11
ATUM391 Subnetwork Mask= 255.255.0.0
ATUM391 Type of Connection= Point to Point
ATUM391 Interface Type= Token Ring
ATUM391 Status= Active
ATUM391 Broadcast Frames Support= YES
ATUM391 Metric= 12
ATUM391 Fragmentation Supported= NO
ATUM391 MTU Size=350
```

Explanation: NTuneMON display for PA2=LOG from the ATUID IP Interface Information Detail panel.

User Response: See “ATUID IP Interface Information Detail Panel” on page 4-164 for more information.

ATUM381

```

ATUM381 IP Router Statistics aa
ATUM441 aaaaaaaaaaaaaa =
ATUM436 NCP27E IPPPOOL INUSE= 25 100% DEFINED= 25
ATUM437 NCP27E IPPPOOL RATE= 0 BURST= 0 FRAME CNT= 0
ATUM438 NCP27E IPPPOOL NCSTs= 2 IPPPOOL IS NOT ALLOCATED
ATUM003 NTUNEMON ENDED
```

Explanation: NTuneMON display for TYPE=IP, or PA2=LOG output from the ATUIS IP Router Statistics Page 1 panel or the ATUIX IP Router Statistics Page 2 panel.

- For NCP V7R1 or later, *aa* will be Page 1 if the display is for the ATUIS IP Router Statistics Page 1 panel or Page 2 if the display is for the ATUIX IP Router Statistics Page 2 panel.
- *aaaaaaaaaaaaa* shows various Internet statistics.

User Response: See “ATUIS IP Router Statistics Page 1 Panel” on page 4-175 or the “ATUIX IP Router Statistics Page 2 Panel” on page 4-180.

ATUM382

```

ATUM382 IP Route Table Entries
ATUM393 HOST ROUTES      Status  Metric  Interface Address
ATUM396 18.0.0.1          INACTIVE 1      18.0.0.1
ATUM394 SUBNETWORK ROUTES Status  Metric  Interface Address
ATUM395 NETWORK ROUTES  Status  Metric  Interface Address
```

Explanation: NTuneMON display for PA2=LOG from the ATUIR IP Route Table Entries panel.

User Response: See “ATUIR IP Route Table Entries Panel” on page 4-172 for more information.

ATUM383

ATUM383 IP Interface Information

ATUM392	Interface	Subnetwork	Metric
ATUM392	Address	Mask	Value
ATUM392	172.55.7.9	255.255.0.0	5
ATUM392	128.48.55.1	255.255.255.0	2
ATUM392	128.46.5.3	255.255.0.0	4
ATUM392	128.55.1.8	255.255.0.0	7
ATUM392	128.28.4.127	255.255.255.0	14

Explanation: NTuneMON display for PA2=LOG from the ATUIL IP Interface Information panel.

User Response: See “ATUIL IP Interface Information Panel” on page 4-169 for more information.

ATUM384

ATUM384 ARP Table Entry Information

ATUM391 IP Address= 202.74.19.2
 ATUM391 H/W Address= 482C6A1E593D
 ATUM391 Frame Format Type Established= YES
 ATUM391 Frame Format Type= ETHERNET V2
 ATUM391 Routing Information= N/A
 ATUM391 Entry Completion Indicator= YES

Explanation: NTuneMON display for PA2=LOG from the ATUIA ARP Table Entry panel.

User Response: See “ATUIA ARP Table Entry Panel” on page 4-155 for more information.

ATUM385

ATUM385 TOKEN-RING IP STATISTICS

ATUM402 ELAPSED TIME SINCE LAST SAMPLING= 0 for A04NTIP
 ATUM421 aaaaaaaaaaaaaaa =
 ATUM417 END OF STATISTICS FOR A04NTIP IP OVER TOKEN RING

Explanation: NTuneMON display for PA2=LOG output from the ATUTI Token-Ring IP Statistics panel. aaaaaaaaaaaaaaa shows various Token-Ring IP statistics.

User Response: See “ATUTI Token-Ring IP Statistics Panel” on page 4-298 for more information.

ATUM386

ATUM386 CHANNEL IP STATISTICS

ATUM402 ELAPSED TIME SINCE LAST SAMPLING= 0 for A04NTIP
 ATUM421 aaaaaaaaaaaaaaa =
 ATUM417 END OF STATISTICS FOR A04NTIP IP OVER TOKEN RING

Explanation: NTuneMON display for PA2=LOG output from the ATUCI Channel IP Statistics panel. aaaaaaaaaaaaaaa shows various Token-Ring IP statistics.

User Response: See “ATUCI Channel IP Statistics Panel” on page 4-36 for more information.

ATUM387

ATUM387 ETHERNET STATISTICS

```

ATUM001 NTuneMON TYPE=ET NCP=NCP27E OUTPUT=LINE ADDR=1071
ATUM400 NCP27E ETHERNET ADDRESS = 400012345671
ATUM401 NCP27E INVERTED ADDRESS = 0200482C6A8E
ATUM402 ELAPSED TIME SINCE LAST SAMPLING= NCP27E
ATUM403 LINE =NCP27E
ATUM421 aaaaaaaaaaaaa = 44/ 14/s
ATUM416 HARDWARE STATISTICS FOR NCP27E 400012345671
ATUM421 bbbbbbbbbbbbbb = 44/ 14/s
ATUM417 END OF STATISTICS FOR NCP27E 0200482C6A8E

```

Explanation: NTuneMON display for TYPE=ET and ADDR=nnn, or PA2=LOG output from the ATUET Ethernet Adapter Statistics panel. aaaaaaaaaaaaa shows various Ethernet-type LAN statistics. bbbbbbbbbbbbbb shows various hardware statistics.

User Response: See "ATUET Ethernet Adapter Statistics Panel" on page 4-84 for more information.

ATUM388**ATUM388 FRAME-RELAY IP STATISTICS**

```

ATUM402 ELAPSED TIME SINCE LAST SAMPLING= 0 for A04NTIP
ATUM421 aaaaaaaaaaaaa =
ATUM417 END OF STATISTICS FOR A04NTIP IP OVER FRAME RELAY

```

Explanation: NTuneMON display for PA2=LOG output from the ATUFI Frame-Relay IP Link Statistics panel. aaaaaaaaaaaaa shows various frame-relay IP statistics.

User Response: See "ATUFI Frame-Relay IP Link Statistics Panel" on page 4-102 for more information.

ATUM440

```

ATUM440 ncp-name ELAPSED TIME SINCE LAST SAMPLING=n SECONDS

```

Explanation: NTuneMON display for PA2=LOG output from the ATUIS IP Router Statistics Page 1 panel.

User Response: See "ATUIS IP Router Statistics Page 1 Panel" on page 4-175 for more information.

ATUM445 to ATUM453

```

ATUM445 NCP27E UTILIZATION CYCLE= 1% BUFFER UTILIZATION= 1%
ATUM446 NCP27E CUC UTILIZATION ACTIVE
ATUM447 STAGE|SECONDS IN | UTILIZATION |
ATUM448      | STAGE      | FOR STAGE   |
ATUM449  1  |      0.9   |    2.03%   |
ATUM449  2  |      1.6   |    1.41%   |
ATUM449  3  |     51.2   |    1.61%   |
ATUM449  4  |    2457.6  |    1.42%   |
ATUM449  5  |   85196.8  |    1.62%   |
ATUM449  6  |   87708.1  |    1.62%   |
ATUM446 NCP27E BUFFER UTILIZATION ACTIVE
ATUM451 |STAGE|SECONDS IN |%BUFFERS | LEASED | FREE |
ATUM452 |     | STAGE     | USED    | BUFFERS| BUFFERS|
ATUM453 |  1  |    0.9    | 0.33%  |   91.2 | 27328.8 |
ATUM453 |  2  |    1.6    | 0.32%  |   89.0 | 27331.0 |
ATUM453 |  3  |   51.2    | 0.32%  |   89.0 | 27331.0 |
ATUM453 |  4  |  2457.6   | 0.33%  |   90.3 | 27329.7 |
ATUM453 |  5  | 85196.8   | 0.33%  |   90.6 | 27329.4 |
ATUM453 |  6  | 87708.1   | 0.33%  |   90.5 | 27330.0 |
    
```

Explanation: NTuneMON display for TYPE=UTIL, or PA2=LOG from the ATUUT NCP Utilization panel.

User Response: See “ATUUT NCP Utilization Panel” on page 4-328 for more information.

ATUM454 to ATUM456

```

ATUM001 NTuneMON TYPE=UTILD NCP=NCP27 OUTPUT=LINE
ATUM454 |NCP27 | UTILIZATION |
ATUM455 |INTERVAL| CUC | BUFFER|
ATUM456 | 0%- 3% | 98% | 7% |
ATUM456 | 4%- 7% | 2%  | 93% |
ATUM456 | 8%- 11%| 0%  | 0%  |
ATUM456 |12%- 15%| 0%  | 0%  |
ATUM456 |16%- 19%| 0%  | 0%  |
ATUM456 |20%- 23%| 0%  | 0%  |
    
```

Explanation: NTuneMON display for TYPE=UTILD. The display shows all intervals from 0% through 100%; however, this sample shows only the intervals from 0% through 23%.

User Response: See “ATUUT NCP Utilization Panel” on page 4-328 for more information.

ATUM460 to ATUM463

```

ATUM001 NTuneMON TYPE=HSCBS NCP=NCP29 OUTPUT=LINE
ATUM460 =NCP29===== NCP == HALF SESSION CB
ATUM461 ID | NETWORK | SUBAREA | IN USE | MAXIMUM |
ATUM462 ---|-----|-----|-----|-----|
ATUM463 00 | USIBMTO | 29      | 6      | 5000    |
ATUM463 01 | RTPLSS  | 4       | 4      | 5000    |
ATUM463 02 | RTDMSS  | 22      | 4      | 5000    |
ATUM463 03 | MBARRY22| 345     | 0      | 5000    |
ATUM463 04 | PAULB16 | 86      | 12     | 300     |
ATUM463 05 | ERNIEG4 | 74      | 456    | 8000    |
ATUM003 NTUNEMON ENDED
    
```

Explanation: NCP releases before NCP V6R1. NTuneMON display for TYPE=HSCB or NN, or PA2=LOG output from the ATUNN HSCBs (Networks and HSCB Counts) panel.

User Response: See “ATUNN HSCBs (Networks and HSCB Counts) Panel” on page 4-201 for more information.

ATUM465 to ATUM468

```

ATUM001 NTuneMON TYPE=GWNAU NCP=NCP29 OUTPUT=LINE
ATUM009 NTuneMON DISPLAYING 60 GWNAUs FOR NETWORK USIBMTO NCP NCP29
ATUM009 NTuneMON DISPLAYING 41 GWNAUs FOR NETWORK RTPLSS NCP NCP29
ATUM465 =NCP29===== NCP ===== N A U =====
ATUM466 ID | NETWORK | IN USE | MAXIMUM |
ATUM467 ---|-----|-----|-----|
ATUM468 00 | USIBMTO | 4      | 60     |
ATUM468 01 | RTPLSS  | 4      | 41     |
    
```

Explanation: NTuneMON display for TYPE=GWNAU or NA, or PA2=LOG output from the ATUNA GWNAU Names and HSCBs panel.

Note: This function can use a large amount of NetView resources and should be used with caution.

User Response: See “ATUNA GWNAU Names and HSCBs Panel” on page 4-192 for more information.

ATUM470 to ATUM476

```

ATUM001 NTuneMON TYPE=NNT NCP=NA3001 OUTPUT=LINE
ATUM470 NA3001 | NETWORKs | NNTs_ | NNTs_AVAILABLE | DYNAMIC_ |
ATUM471         | DEFINED  | DEFINED | CURRENT          | MINIMUM  | NNTs_   |
ATUM472         |=====|=====|=====|=====|=====|
ATUM473         | 5      | 5      | 1      | 1      | 0      |
ATUM474 |=====HISTORY OF NAMES KNOWN TO NCP AND USE COUNTS =====|
ATUM475 |=====|=====|=====|=====|=====|
ATUM476 |NETA   10 |NETB   10 |A17N   3 |B01N   3 |
    
```

Explanation: NTuneMON display for TYPE=NNT or NT, or PA2=LOG output from the ATUNT NCP Network Names Table panel.

User Response: See “ATUNT NCP Network Names Table Panel” on page 4-209 for more information.

ATUM477 to ATUM480

ATUM477	NA3001	NCP BUF	CUR	MAX	ALERT	CUR	MAX	
ATUM478		POOL	USE	USE	THRSH	USE	USE	TOTAL
ATUM479		*****						
ATUM480		BPOOL	0%	0%	62%	0	0	26448
ATUM480		BUFFERS	0%	0%	90%	92	0	105793
ATUM480		IPPOOL	0%	0%	75%	0	0	0
ATUM480		DYNPOOL	0%	0%	101%	35	0	12000

Explanation: NTuneMON display for TYPE=BUF, BUFPOOL, or BUFFERS or PA2=LOG output from the ATUBP NCP Buffer Pool.

User Response: See “ATUBP NCP Buffer Pool Panel” on page 4-4 for more information.

ATUM481 to ATUM482

```

ATUM001 NTuneMON TYPE=ARP NCP=NCP27E OUTPUT=LINE
ATUM481 NCP27E 1071 DYNAMIC ARPs IN USE=100 10% DEFINED=1000
ATUM482 NCP27E 1071 INCOMPLETE ARPs = 0
    
```

Explanation: NTuneMON display for TYPE=ARP.

This display lists the following:

- Number and percentage of permanent and dynamic ARP entries defined and in use
- Number of dynamic ARP entries that are incomplete.

Note: This function might use a large amount of NetView resources and should be used with caution.

User Response: See *NCP, SSP, and EP Resource Definition Reference* for more information.

ATUM485

ATUM485 NCP BUFFER SLOWDOWN INFORMATION

```

ATUM699
ATUM699          (variable data)
ATUM699
:
    
```

Explanation: NTuneMON display for PA2=Log from the ATUBS Buffer Slowdown Information Page 1 panel or the ATUBX Buffer Slowdown Information Page 2 panel.

User Response: See “ATUBS Buffer Slowdown Information Page 1 Panel” on page 4-10 or “ATUBX Buffer Slowdown Information Page 2 Panel” on page 4-14 for more information.

ATUM490 to ATUM493

ATUM490 NA3001	CURRENT NCP CONTROL BLOCK POOLS AND TABLES IN USE									
ATUM491 TYPEs	MAX	CUR	THRSH	MAX	CUR	UNRSVD	RSVD	TOTAL	DYNA	ASSIGN
ATUM492 HSCB	100%	100%	80%	4	4	0	0	4	4	190
ATUM492 PUDR	100%	100%	80%	12	12	0	0	12	2	57
ATUM492 LUDR	100%	100%	60%	45	45	0	0	45	0	0
ATUM492 LND	100%	100%	80%	45	45	0	0	45	0	0
ATUM492 LNB	0%	0%	75%	0	0	0	0	0	0	0
ATUM492 BSB	0%	0%	90%	0	0	0	0	0	0	0
ATUM492 LTX	0%	0%	80%	0	0	0	0	0	0	0
ATUM492 NUMHSAS	0%	0%	80%	3	3	646	0	649	0	0
ATUM492 NNT	80%	80%	80%	4	4	1	0	5	0	0
ATUM492 VVT	2%	2%	80%	4	4	149	0	153	0	0
ATUM492 NSX	84%	84%	80%	21	21	4	0	25	21	0
ATUM492 NSC	100%	100%	85%	9	9	0	0	9	9	0
ATUM492 LUX	0%	0%	80%	0	0	0	0	0	0	0
ATUM492 TR LLB	0%	0%	80%	0	0	50	0	50	0	1
ATUM492 FR LLB	0%	0%	80%	0	0	0	0	0	0	4
ATUM492 ODLC LAN	0%	0%	80%	0	0	0	0	0	0	0
ATUM492 FCT	69%	69%	80%	336	336	150	0	486	0	0
ATUM492 HRE	0%	0%	80%	0	0	0	0	0	0	0
ATUM492 NRE	0%	0%	80%	0	0	0	0	0	0	0
ATUM492 SRE	0%	0%	80%	0	0	0	0	0	0	0
ATUM492 NQE	0%	0%	80%	0	0	142	0	142	0	0
ATUM492 NQX	0%	0%	80%	0	0	0	0	0	0	0
ATUM492 NSB	0%	0%	80%	0	0	2	0	2	0	0
ATUM492 RVT	75%	75%	80%	6	6	2	0	8	6	257
ATUM492 NVT	0%	0%	80%	0	0	3	0	3	0	2
ATUM492 SNP	37%	37%	80%	3	3	5	0	8	0	0

Explanation: NTuneMON display for TYPE=CBPOOL, or PA2=LOG output from the ATUCB Control Block Pools/Tables panel.

User Response: See “ATUCB Control Block Pools/Tables Panel” on page 4-17 for more information.

ATUM494

ATUM490 NA3001	CURRENT NETWORK CONTROL BLOCK POOLS AND TABLES IN USE									
ATUM494 NETWORK = NETA SUBAREA = 3										
ATUM491 TYPEs	MAX	CUR	THRSH	MAX	CUR	UNRSVD	RSVD	TOTAL	DYNA	ASSIGN
ATUM492 GWNAU	100%	100%	80%	2	2	0	0	2	2	3
ATUM492 TGB	26%	26%	80%	4	4	11	0	15	0	0
ATUM492 TRT	2%	2%	80%	7	7	247	0	254	0	0

Explanation: NTuneMON display for TYPE=CBPOOL, or PA2=LOG output from the ATUGP Network CB Pools/Tables panel. It shows pools in a per network basis. Information for PUDR, LUX, HSCB, and VVT is displayed only for NCP V6R2 and later.

User Response: See “ATUCB Control Block Pools/Tables Panel” on page 4-17 for more information.

ATUM495 to ATUM499

ATUM495	NCP	CNTL		EC-LVL	CCU-MODE	USAGE
ATUM496	SUBAREA	SIZE	S/N	FIX-LVL	CDS-UPDATED	TIER
ATUM497	=====	=====	=====	=====	=====	=====
ATUM498	D44PNR	3745-41A	0003593	D39886	TWIN-DUAL(B)	5
ATUM499	44	8MB		M886A067	92/11/23 09:48	
ATUM498	D45PNR	3745-41A	0003594	D39886	TWIN-DUAL(A)	5
ATUM499	45	8MB		M886A067	92/11/23 09:48	
ATUM498	D46PNR	3745-41A	0003595	D39886	TWIN-DUAL(B)	5
ATUM499	46	8MB		M886A067	92/11/23 09:48	
ATUM498	D47PNR	3745-41A	0003596	D39886	TWIN-DUAL(A)	5
ATUM499	47	8MB		M886A067	92/11/23 09:48	
ATUM498	D48PNR	3745-41A	0003597	D39886	TWIN-DUAL(B)	4
ATUM499	48	8MB		M886A067	92/11/23 09:48	

Explanation: NTuneMON display for TYPE=CDS or CD, or PA2=LOG output from the ATUCD CDS NCP Selection panel.

User Response: See "ATUCD CDS NCP Selection Panel" on page 4-27 and "ATUCD CDS NCP Selection Panel" on page 4-27 for more information.

ATUM505 to ATUM507

ATUM509	NA3001	GWNAUS	FOR	NETA	INUSE=100%/2	PERM=3	FRSVD=0	TOTAL=2
ATUM512	MAX	IN	USE=100%/2		DYNA=2		FUNRSVD=0	
ATUM506	=====	=====	=====	=====	=====	=====	=====	=====
ATUM507	B01N	1	B128N	0	C01N	0		

Explanation: NTuneMON display for TYPE=GWNAUD or IB, or PA2=LOG output from the ATUIB GWNAUs in Use Counts panel.

Note: This function can use a large amount of NetView resources and should be used with caution.

User Response: See "ATUIB GWNAUs in Use Counts Panel" on page 4-158 for more information.

ATUM508 RESERVED GWNAUS FOR *network-id* INUSE=*in-use* TOTAL=*total*

Explanation: NTuneMON display for TYPE=GWNAU or GWNAUD, or PA2=LOG output from the ATUIB GWNAUs in Use Counts panel.

User Response: See "ATUIB GWNAUs in Use Counts Panel" on page 4-158 for more information.

ATUM510 to ATUM511

```

ATUM001 NTuneMON TYPE=HEX NCP=NCP30 OUTPUT=LINE DISPLAY HEX ADDR=23020

ATUM510 NCP30 NCP STORAGE ADDRESS=023020
ATUM511 + 0 0051F0F6 61F0F861 F9F240F1 F27AF1F3 *.06/08/92 12:13*
ATUM511 + 10 7AF3F9C1 C3C640E2 E2D740E5 F3D9F640 *:39NTUNEMON V1R1 *
ATUM511 + 20 40C1C3C6 40D5C3D7 40E5F5D9 F4404001 * ACF NCP V5R4 .*
ATUM511 + 30 C3E7D9D5 D9C64040 E7F2F5D5 D7E2C940 *CXRNRF X25NPSI *
ATUM511 + 40 F0F661F0 F861F9F2 40F1F27A F1F37AF3 *06/08/92 12:13:3*
ATUM511 + 50 F9000000 00000000 4C100016 11011300 *9.....<.....*
ATUM511 + 60 11F3F7F4 F5F4F1F0 F0F0F0F0 F0F2F7F7 *.374541000000277*
:
ATUM511 +120 000000C0 0710D1C6 0000030F 00001EFE *.....JF.....*
ATUM511 +130 000000C0 0710D1E0 00000107 000400FE *.....J.....*
    
```

Explanation: NTuneMON display for HEX=*address*, or PA2=LOG output from the ATUDP Hexadecimal Storage Display panel.

User Response: See "ATUDP Hexadecimal Storage Display Panel" on page 4-68 for more information.

ATUM515 to ATUM518

```

ATUM515 NCP WIDE VIEW OF NCPs
ATUM516 NCP SUBAREA NCP-VER CNTL MEM S/N CCU BUF NET HSCBS NNTs LUB NHSAS
ATUM517
ATUM518 NCP27 27 V5R4 3745-410 8MB 0002779 12% 20% 1 0 2% 0% 66%
ATUM518 NCP29 29 V4R3.1 3725 2MB 0004162 40% 16% 2 26 4% 0% 41%
ATUM518 NCP30 30 V5R4 3745-410 8MB 0002779 - - 2 0 18% 4% 37%
ATUM518 NCP40 40 V6R1 3745-410 8MB 0045410 15% 23% 1 0 3% 0% 66%
    
```

Explanation: NTuneMON display for TYPE=NW, or PA2=LOG output from the ATUNW NCP Wide Selection panel.

Because these messages are long, they wrap on the NetView screen. It is recommended that you direct them to the NetView log.

User Response: See "ATUNP NCP Selection Panel" on page 4-204 and "ATUNW NCP Wide Selection Panel" on page 4-212 for more information.

ATUM520

```

ATUM520 A04NT06 LINE ADDR=1088 MAC=400000041088 16M TIC2
ATUM519 TITIMER = 60.0 DYNWIND(nw,dw,dwc) = 4 2 1
ATUM699 (variable data)
ATUM521 PHYPORT=1 ADAPTER STATE=ACTIVE ANY
ATUM525 MAXTSL =16732 RCVBUFC =32000 RECEIVE CONGESTION=0
ATUM531 ACTIVE LINES=0 RESERVED=0 ACTIVE= 0%
ATUM537 MAX SIZE MIN SIZE NUMBER EST
ATUM537 COMRATE FR SENT FR SENT FR SENT BYTES
ATUM537 TIC N/A 156 156 1 -
ATUM537 FR 1 - - - -
ATUM537 SNA 1 - - - -
ATUM524 SNA PASSLIM = N/A
ATUM524 IP PASSLIM = N/A
ATUM524 DATABLK = 2048 MAXFRAME = 8000
ATUM533 LAST BEACONING=|400000711088|--X--|400000041092| ON 00:20 AT 01/01/2000
    
```

Explanation: NTuneMON for TYPE=TP, or PA2=LOG output from the ATUTP1 Token-Ring TIC Details Page 1 or ATUTP2 Token-Ring TIC Page 2 panel.

User Response: See "ATUTP1 Token-Ring TIC Details Page 1 Panel" on page 4-310 or "ATUTP2 Token-Ring TIC Details Page 2 Panel" on page 4-319 for more information.

ATUM522 to ATUM530

```

ATUM513 T1REM=- T2REM=- GEN/CUR BLOCK=N/A/N/A PIUS/ BLOCK=N/A
ATUM514 SUBAREA= TG=- WW/OUTS. FRAME CT=-/- N3/ I-FRAME RCV CT=TLN3I
ATUM520 NA3001 LINE ADDR=1088 MAC=400000000331 16M TIC2
ATUM521 PHYPORT=1 ADAPTER STATE=INACTIVE ANY
ATUM522 DEST MAC=- SAP=- LINE=-
ATUM523 IDBLK-IDNUM=- CPNAME=- NETWORK=-
ATUM524 (variable data)
ATUM525 MAXTSL =2012 RCVBUFC =4072 RECEIVE CONGESTION=0
ATUM526 GEN/CUR MAXDATA=/ MAX BRIDGE=16732 T1LOC=- T2LOC=-
ATUM527 FRAMES SENT=- RECEIVED=- GEN/CUR MAXOUT=/
ATUM528 ROUTE GOES OVER 0 BRIDGES - LLC STATUS=
ATUM529
ATUM529 |-----|-----|-----|-----|-----|-----|
ATUM529 | 008 | - | C0A | - | B00 | - | C0E | - | 108 | - | 10B |
ATUM529 |-----|-----|-----|-----|-----|-----|
ATUM529 | 1 | 1 | 1 | 1 | 0 |
ATUM530 REMOTE NCP=A04A54C SUBAREA= 63 TG= 1
    
```

Explanation: NTuneMON PA2=LOG output from the ATUTL Token-Ring SNA Station panel.

User Response: See “ATUPL SDLC Physical Line Details Panel” on page 6-102, for more information.

ATUM535

```

ATUM001 NTuneMON TYPE=SCANNERS NCP=NCP27 OUTPUT=LINE
ATUM535 NCP27 LINE AND CHANNEL SCANNERS USAGE TIER=5
ATUM536 ADPT TYPE INST OPER ATT SW LINES
ATUM537 1 TRA Y OPER - - 1088-1089
ATUM537 2 - - - - - -
ATUM537 3 HPTSS Y OPER - - 1028-1029
ATUM537 4 TSS Y OPER - - 0-15
ATUM537 5 TRA Y OPER Y - 1092-1093
ATUM537 6 - - - Y Y -
ATUM537 7 ETHER Y OPER Y - 1068-1069
ATUM537 8 ETHER Y OPER Y - 1070-1071
    
```

Explanation: NTuneMON display for TYPE=SCANNERS or SC, TYPE=ADAPTERS, or PA2=LOG output from the ATUSC1 Channel Adapters or ATUSC2 Line Adapters Page 1 panel.

User Response: See “ATUSC1 Channel Adapters Panel” on page 4-230 or “ATUSC2 and ATUSC3 Line Adapters Panels” on page 4-233 for more information.

ATUM537

Example 1: ATUTD NTRI Frame Handler Logical Line Details Panel

```

ATUM537 LINE NAME= A04FTLLN PHYPORT= 1
ATUM537 COMRATE= 1 DATABLK= 2048 MAXFRAME= 8000
ATUM537 MAX DLCI= 991 0 T1REM= 2.5
ATUM537 MAX SIZE FRAME= 1025 MIN SIZE FRAME= 65535
ATUM537 NUMBER FRAMES= 0 EST BYTES= -
ATUM537 LMI= ANSI PU STATUS= INACTIVE
ATUM537 LVL3 DISCARDS= 0 LVL5 DISCARDS= 0
ATUM537 N391= 6
ATUM537 USER NETWORK
ATUM537 N392= 3/0 N392= 3/0
ATUM537 N393= 4 N393= 4
ATUM537 T391= 10 SEC T392= 15 SEC
ATUM537 SEND= 0(00) SEND= 0(00)
ATUM537 RCVD= 0(00) RCVD= 0(00)
    
```

Example 2: ATUTF NTRI Frame Handler Logical Lines List Panel

```

ATUM537 LINE NAME= A04FTLLN MAC ADDR= 400000711088 COMRATE= 1
ATUM537 MAX FRAME= 1025 MIN FRAME= 65535
ATUM537 NUMBER FRAMES= 0 EST BYTES= -
ATUM537 LINE NAME= A04FTBLN MAC ADDR= 400000711089 COMRATE= 1
ATUM537 MAX FRAME= 1025 MIN FRAME= 65535
ATUM537 NUMBER FRAMES= 0 EST BYTES= -
    
```

Explanation: NTuneMON display for PA2=LOG output from the ATUTF NTRI Frame Handler Logical Lines or ATUTD NTRI Frame Handlers Logical Line Details panel.

User Response: See “ATUTF NTRI Frame Handler Logical Lines Panel” on page 4-291 or “ATUTD NTRI Frame Handlers Logical Line Details Panel” on page 4-285 for more information.

ATUM538 to ATUM541

ATUM538	NCP	CHANNELS				PGM	UNTSZ			
ATUM539	ADPT	TYPE	INST	OPER	ATT	SW	SUBA	MXBF	RU	TPS
ATUM540	0	CADS	Y	OPER	Y	-	NCP	384	-	-
ATUM541	5						1	41		
ATUM540	1	CADS	Y	OPER	Y	-	-	-	-	-
ATUM541	6									
ATUM540	2	CADS	Y	OPER	Y	-	-	-	-	-
ATUM541	7									
ATUM540	10	CADS	Y	OPER	-	-	-	-	-	-
ATUM541	3									
ATUM540	11	-	-	-	-	-	-	-	-	-
ATUM541	4									

Explanation: NTuneMON display for TYPE=SCANNERS or SC, TYPE=ADAPTERS, or PA2=LOG output from the ATUSC1 Channel Adapters panel or the ATUSC2 Line Adapters Page 1 panel.

User Response: See “ATUSC1 Channel Adapters Panel” on page 4-230 or “ATUSC2 and ATUSC3 Line Adapters Panels” on page 4-233 for more information.

ATUM542 to ATUM544

ATUM542	3746	MODEL	900	ADAPTERS						
ATUM543	POS	TYPE	LINES	INST	OPER	ATT	UTIL	SDS	PDS	
ATUM544	2	CBSP	2048 2080	Y	OPER	Y				
ATUM544	3	TRP	2112 2144	Y	OPER	Y				
ATUM544	4	TRP	2176 2208	Y	OPER	Y				
ATUM544	5	ESCP	2240 2272	Y	OPER	Y				
ATUM544	6	ESCP	2304 2336	Y	OPER	Y				
ATUM544	7	-	2368	-	-	Y				
ATUM544	8	-	2432	-	-	Y				

Explanation: NTuneMON display for TYPE=SCANNERS or SC, TYPE=ADAPTERS, or PA2=LOG output from the ATUSC4 3746 Model 900 Adapters panel.

User Response: See “ATUSC4 3746 Model 900 Adapters Panel” on page 4-237 for more information.

ATUM548 to ATUM553

ATUM001	NTuneMON	TYPE=ETHER		NCP=NCP27E		OUTPUT=LINE				
ATUM548	NCP27E	ETHERNET ADAPTERS								
ATUM549	3745	NCP	MAC	FRAMES	XMIT/RECEIVED	XMIT				
ATUM550	ADPT	LINE	ADDRESS	DATA	BRDCSTs	DISCARD	QUEUED			
ATUM551	_____	_____	_____	_____	_____	_____	_____	_____	_____	_____
ATUM552	7	1068	-	-	-	-	-	-	-	-
ATUM553										
ATUM552	7	1069	400012345669	-	-	-	-	-	0	
ATUM553										
ATUM552	8	1070	-	-	-	-	-	-	-	
ATUM553										
ATUM552	8	1071	400012345671	-	-	-	-	-	0	
ATUM553										

Explanation: NTuneMON display for TYPE=ETHER or EP, or PA2=LOG output from the ATUEP Ethernet Adapter List panel.

User Response: See “ATUEP Ethernet Adapter List Panel” on page 4-81 for more information.

ATUM570 to ATUM577

```

ATUM570 NCP2762 FRAME RELAY LINE ADDR=24 STATUS=ACTIVE
ATUM571 LINE NAME=T02724L SPEED=N/A TYPE=TSS Full Duplex
ATUM572 FRAME STATISTICS TRANSMITTED RECEIVED MAXFRAME=2106
ATUM573 TOTAL FRAMES 25583 3/S 25577 2/S
ATUM573 TOTAL RETRIES 0
ATUM573 I-FRAME RETRIES 0
ATUM573 FRAME FORMAT ERRORS 0
ATUM574 LMI=ANSI Network and User Side
ATUM575 LVL3 DISCARDS=0 LVL5 DISCARDS=0
ATUM576 LMI Counts and Timers USER NETWORK
ATUM577 Full Status Polling Count N391= 6 -
ATUM577 Error Count/Threshold N392= 3/0 3/0
ATUM577 Monitored Events Count N393= 4 4
ATUM577 Link Integrity Polling Timer T391= 10 Sec -
ATUM577 Polling Verification Timer T392= - 15 Sec
ATUM577 LMI Send Sequence Numbers SEND= 58(3A) 57(39)
ATUM577 LMI Receive Sequence Numbers RCVD= 58(3A) 176(B0)
    
```

Explanation: NTuneMON display for TYPE=FP, or PA2=LOG output from the ATUFP Frame Relay Physical Line Details Page 1 panel.

User Response: See “ATUFP Frame Relay Physical Line Details Page 1 Panel” on page 4-108 for more information.

ATUM580 to ATUM581

```

ATUM580 NCP2762 FRAME RELAY LIST OF DLCI FRTE ON ADDR=24
ATUM581 FRAME RELAY DLCI LOGICAL LINES DISPLAYED = 2/ 51
ATUM577 49(31) FRSE 50(32) FRTE
    
```

Explanation: NTuneMON display for TYPE=DLCI, TYPE=FRSE, TYPE=FRTE, or PA2=LOG output from the ATUFA Frame Relay Subport List panel.

User Response: See “ATUFA Frame Relay Subport List Panel” on page 4-88 for more information.

ATUM585 to ATUM589

```

ATUM585 A04NT06 TESP DLCI=48(30) PHYSICAL LINE ADDR=4
ATUM586 LINE NAME=A04LL30 PU NAME=A04LP30 DSAP=04 T1=20.0 T2=1.0
ATUM589 LINE STATUS=INACTIVE PU STATUS=INACTIVE COMRATE=(FULL,1)
ATUM583 LINE TYPE=TSS PORTADD=118 MAXFRAME=8000 N3GEN=10
ATUM584 SUBAREA=- NETID=- TG=- PIUS/BLOCK=0
ATUM588 LLC STATUS: LOGICAL LINK CLOSED
ATUM588 BECNs RECEIVED 0
ATUM588 FECNs RECEIVED 0
ATUM588 DE BITS SET 0
ATUM588 FRAMES DISCARDED 0
ATUM588 IDBLK-IDNUM = - CPNAME = -
ATUM588 DYNWIND (NW)=4 (DW)=2 (DWC)=2
ATUM588 CURRENT GENNED
ATUM588 MAXDATA 0 0
ATUM588 MAXOUT 127 127
ATUM588 BLOCK 0 0
ATUM587 TESP FRAME STATISTICS TRANSMITTED RECEIVED
ATUM588 DLCI STATUS INACTIVE INACTIVE
ATUM588 WW / OUTS. FRAME CT -/-
ATUM588 N3 / I-FRAME RCV CT -/-
ATUM588 FRAME COUNTS - -
ATUM588 ESTIMATED BYTES - -
ATUM588 MAX SIZE FRAME - -
ATUM588 MIN SIZE FRAME - -
    
```

Explanation: NTuneMON display for TYPE=FT, or PA2=LOG output from the ATUFT1 Frame Relay Terminating Equipment Page 1 or ATUFT2 Frame Relay Terminating Equipment Page 2 panel.

User Response: See "ATUFT1 Frame Relay Terminating Equipment Details Page 1 Panel" on page 4-135 or "ATUFT2 Frame Relay Terminating Equipment Details Page 2 Panel" on page 4-143 for more information.

ATUM590 to ATUM592

```

ATUM590 D44PNR 3746 MODEL 900 LINE=2240 TYPE=ESCP NAME=D44S2240 STATUS=ACTIVE
ATUM591 ADDR TYPE NAME STATUS CUR MIN MAX UNTSZ MBFRU SUB/CP
ATUM592 2(02) Link D44S1L2 ACTIVE
ATUM592 1(01) T5 D44S1P21 ACTIVE 10 1 10 256 250 45.1
ATUM592 3(03) T2.1 D44TPFP1 XID PEND 1 1 10 N/A 32
ATUM592 4(04) T2.1 D44TPFP1 ACTIVE 10 1 10 3 32 CPERNIE
ATUM592 4(04) T5 D44S1P24 ACTIVE 10 1 10 256 31 45.4
ATUM592 3(03) Link D44S1L3 ACTIVE
ATUM592 1(01) T2.1 D44S1P31 ACTIVE 1 1 4 256 3
ATUM592 2(02) T2.1 D44S1P32 ACTIVE 4 1 4 256 3
ATUM592 4(04) Link D44S1L4 ACTIVE
ATUM592 1(01) T5 D44PUT5 XID PEND 1 1 10 N/A 32 TGN=1
ATUM592 7(07) Link D44S1L7 ACTIVE
ATUM592 1(01) T5 D44S1P71 XID PEND 1 1 10 N/A 32 TGN=1
    
```

Explanation: NCP V6R2 or later NTuneMON display for TYPE=CSS, TYPE=CH, or PA2=LOG output from the ATUCS 3746-900 Logical Lines panel.

User Response: See "ATUCS 3746-900 Logical Lines Panel" on page 4-43 for more information.

ATUM593 to ATUM598

Example 1: PA2 from ATUCL 3746-900 Station Details Panel

```

ATUM590 NA3001 ADAP POS= 1 TYPE=CADS NAME=A03CP1 STATUS=ACTIVE
ATUM593 Addr=- Name=A03PP1A Type=T5 STATUS=ACTIVE
ATUM594 SUBAREA.TG OR CPNAME= 17.1 NETWORK=NETA
ATUM595 UNITSZ=384 MAXBFRU GEN/CUR=16/0 TRANSFER=16128
ATUM596 DELAY GEN/CUR=0.2/0.2 TIMEOUT GEN/CUR=180/0 CASDS=420
ATUM598 OUTBOUND QUEUE THRESHOLDS LOW=128 HIGH=256
    
```

Example 2: PA2 from ATUCH Channel Adapter Details Panel

```

ATUM590 A04ALL ADAP POS= 5 TYPE=BCCA NAME=A04C00 STATUS=ACTIVE
ATUM593 ADDR=- NAME=A04P00A TYPE=T5 STATUS=ACTIVE
ATUM594 SUBAREA.TG or CPNAME= 2.1 NETWORK=N/A
ATUM595 UNITSZ=384 MACBFRU BEN/CUR=100/96 TRANSFER=77184
ATUM596 DELAY GEN/CUR=0.2/0.0 TIMEOUT GEN/CUR=240/239.9 CADS=42-
ATUM598 OUTBOUND QUEUE THRESHHOLDS LOW=800 HIGH=1600
ATUM592 NEGATIVE POLLS = -
ATUM592 POSITIVE POLLS = -
ATUM592 TOTAL POLLS = -
    
```

Explanation: NTuneMON display for TYPE=CSS or PA2=LOG output from the ATUCL 3746-900 Station Details panel or the ATUCH Channel Adapter Details panel.

User Response: See "ATUCL 3746-900 Station Details Panel" on page 4-39 or "ATUCH Channel Adapter Details Panel" on page 4-32 for more information.

ATUM600 to ATUM604

```

ATUM600 NCP3062 MULT-LINK TG - NETWORK=USIBMTO SUBAREA= 27 TGN= 1
ATUM601 MAX TRANSFER=2090 TRANSMIT QUEUE=3 OUT OF SEQ TGCONF=MULTI
ATUM602 SEQUENCE NUMBERS OUTBOUND=339 INBOUND=348
ATUM603 PRI LINE PU TYPE STATUS
ATUM604 0 T03040L T030FRP1 FRTSS ACTIVE
ATUM604 0 T030HSP T030HSP1 HPTSS ACT/XMIT
ATUM604 0 T030TR1 T030TRP1 16MTIC3 ACT/XMIT
ATUM604 0 T030TR2 T030TRP2 4MTIC2 ACT/XMIT
ATUM604 0 T030D1 T030DP1 DIAL ACT/XMIT
ATUM604 0 T030E1 T030EP1 TRHPTSS ACT/ERP
    
```

Explanation: NTuneMON display for TYPE=MLTG, or PA2=LOG output from the ATUML Multi-Link Transmission Group panel.

User Response: See "ATUML Multi-Link Transmission Group Panel" on page 4-184 for more information.

ATUM606 to ATUM609

```

ATUM606 A04ALL LINE NAME=A04CCN35 ADDRESS=( 35,HALF) STATUS=INACTIVE
ATUM607 SPEED=50 TYPE=TSS ELEM ADDR=19 PAUSE=( 0.2, 2.8 )
ATUM608 SWITCHED DUPLEX=FULL NRZI=YES LPDA Not Supported TAILED=N/A
ATUM609 LAST PSA ERROR STATUS: 00000000 00000000 00000000 00000000
ATUM614 LSPRI = LINK SERLIM = 1
ATUM612 NEGATIVE POLLS = -
ATUM612 POSITIVE POLLS = -
ATUM612 TOTAL POLLS = -
    
```

Explanation: NTuneMON display for TYPE=PL or PS2=LOG output from the ATUPL SDLC Physical Line Details panel.

User Response: See the ATUPL SDLC Physical Line Details panel for more information.

ATUM610 to ATUM612

```

EXAMPLE 1
ATUM610 NA3001 LINE ADDR=34 NAME=A03S34 MAXOUT STATUS=ACTIVE
ATUM611 ADDR TYPE NAME STATUS PASSLIM LMT CUR MAXDATA SUB.TG ROLE
ATUM612 193(C1) T2 A03P34A XID PEND 8 7 0 265 N/A PRIMARY
ATUM612 195(C3) T2 XID PEND 5 7 0 256 N/A PRIMARY
ATUM612 196(C4) T2 XID PEND 5 7 0 256 N/A PRIMARY
    
```

```

EXAMPLE 2
ATUM610 NA3001 LINE ADDR=1028 NAME=A03S128 MAXOUT STATUS=INACTIVE
ATUM611 ADDR TYPE NAME STATUS PASSLIM LMT CUR MAXDATA SUB.TG ROLE
ATUM612 3(03) T4 A03P128 INACTIVE 254 127 0 0 TGN=1 PRIMARY
    
```

Explanation: NTuneMON display for TYPE=SL, PA2=LOG output for the ATUSL SDLC Stations List panel.

User Response: See the ATUSL SDLC Stations List panel for more information.

ATUM615 to ATUM618

```

ATUM615 MODIFY TIMER VALUE = NCP = A04ALL KEYWORD REPLYTO = 3.0
ATUM616
ATUM617 | NONE | 0.0 | 6.5 | 30.0 |
ATUM618 |-----|-----|-----|-----|
ATUM617 | 1.0 | 2.2 | | |
ATUM618 |-----|-----|-----|-----|
ATUM617 | 3.0 | 23.5 | | |
ATUM618 |-----|-----|-----|-----|
ATUM617 | 60.0 | 4.2 | | |
ATUM618 |-----|-----|-----|-----|
    
```

Explanation: NTuneMON display for PA2=LOG output from the ATUMT Modify Timer Value panel.

User Response: See “ATUMT Modify Timer Value Panel” on page 4-189 for more information.

ATUM620

```

ATUM620 A04ALL  PU NAME=A04PC35  STATUS=INACTIVE NETID=N/A
ATUM621 NCP ROLE=CONFIG SUBAREA=N/A TG=N/A #PIUS/BLOCK=N/A
ATUM588                                TRANSMIT  RECEIVE
ATUM588 TOTAL FRAMES                    0          0
ATUM588 TOTAL I-FRAMES                   0          0
ATUM588 OUTSTANDING FRAME CNT            0          -
ATUM588                                CURRENT    GENNED
ATUM588 PASSLIM                           0          0
ATUM588 MAXDATA                            0          0
ATUM588 MAXOUT                             0          0
ATUM588 BLOCK                             N/A        N/A
ATUM588 RETRIES                           15         0
ATUM588 NEG POLL                          0
ATUM588 POS POLL                          0
ATUM588 TOTAL POLL                        0
ATUM651 HPR DATA
ATUM651 HPRQLIMIT                         = 20001
ATUM651 HPR bytes queued                   = 0
ATUM651 X-NLPs discarded                   = 1
ATUM651 R-NLPs discarded                   = 2
    
```

Explanation: NTuneMON display for PA2=LOG output from the ATUSD SDLC Station Details panel.

Note: The HPR information is available only for peripheral nodes.

User Response: See “ATUSD SDLC Station Details Panel” on page 4-241 for more information.

ATUM622 to ATUM626

```

ATUM622                                NTUNENCP TABLE ENTRIES
ATUM623 NTUNENCP FEATURE
ATUM625 | ADDR | BYTE | ADDR | BYTE | ADDR | BYTE | ADDR | BYTE |
ATUM626 |456234| 04 |434430| 01 |F5D400| 02 |DDFE44| 01 |
ATUM626 |CCBBAA| 02 |453564| 01 |D4F5A2| 01 |DFDDED| 01 |
ATUM624 NEXT LINE LAST ENTRY USED OFFSET 4
ATUM626 |123456| 02 |002456| 01 |000300| 01 |450045| 02 |
    
```

Explanation: NTuneMON display for PA2=LOG output from the ATUNI NTuneNCP Information panel. ATUM626 is a list of the addresses that have been modified and the number of bytes that were changed. ATUM624 points to the address of the last change made for this NCP. In this example, offset 4 indicates that the fourth address was the last to be changed.

Note: This table will wrap when full.

User Response: See “ATUNI NTuneNCP Information Panel” on page 4-199 for more information.

ATUM628

```

ATUM628                                CIR TABLE INFORMATION BY DLCI
ATUM699
ATUM699                                (variable data)
ATUM699
:
    
```

Explanation: NTuneMON display for PA2=Log from the ATUFB Frame Relay DLCI CIR Parameters panel.

User Response: See "ATUFB Frame Relay DLCI CIR Parameters Panel" on page 4-92 for more information.

ATUM629

```

ATUM629          DLCI Balance Factor Table
ATUM699
ATUM699          (variable data)
ATUM699
:
```

Explanation: NTuneMON display for PA2=Log from the ATUFD Frame Relay DLCI to Balance Table panel.

User Response: See "ATUFD Frame Relay DLCI to Balance Table Panel" on page 4-99 for more information.

ATUM630 to ATUM631

```

ATUM630          SDLC Peripheral Line Parameters
ATUM631 LINE NAME      = A04NCP          ELEMENT ADDR = 234
ATUM631 NCP USE        = Defined Redef   VTAM USE      = Defined Redef
ATUM631 LINE STATUS    = INACTIVE        LINE TYPE     = HPTSS
ATUM631 LINE ADDRESS   = 32,FULL        ANSWER TONE  = NO
ATUM631 AUTO           = NO              CCLID        = NO
```

Explanation: NTuneMON display for PA2=LOG output from the ATUSP1 SDLC Peripheral Line Parameters Page 1 and ATUSP2 SDLC Peripheral Line Parameters Page 2 panels.

User Response: See the "ATUSP1 SDLC Peripheral Line Parameters Page 1 Panel" on page 4-249 or "ATUSP2 SDLC Peripheral Line Parameters Page 2 Panel" on page 4-255 for more information.

ATUM633 to ATUM635

```

ATUM633          The J-Lines Control Block Display
ATUM634 Owing      ODLC      NCP      ODLC      ISDN
ATUM635 Host      LAN      NTRI      FR      FR      PERIP  SUBAREA
ATUM699
ATUM699          (variable data)
ATUM699
:
```

Explanation: NTuneMON display for PA2=LOG output from the ATUCX Control Block Pools Extension panel.

User Response: See "ATUCX Control Block Pools Extension Panel" on page 4-47 for more information.

ATUM639

```

ATUM639          Frame Relay Multi Station List
ATUM699
ATUM699          (variable data)
ATUM699
:
```

Explanation: NTuneMON display for PA2=LOG output from the ATUFL Frame Relay Multi Station List panel.

User Response: See "ATUFL Frame Relay Multi Station List Panel" on page 4-105 for more information.

ATUM640

```

ATUM640 VIRTUAL ROUTE DETAILS
ATUM699
ATUM699 (variable data)
ATUM699
:
```

Explanation: NTuneMON display for PA2=LOG output from the ATUVA Virtual Route Control Block Details panel.

User Response: See “ATUVA Virtual Route Control Block Details Panel” on page 4-331 for more information.

ATUM650

```

ATUM650 ----- HIGH PERFORMANCE ROUTING -----
ATUM650 BYTES = 0
ATUM650 QUED LMT = 20000
ATUM650 DISCARDED FID4S RXD= 0 XMT= 0
ATUM650 BYTES =
ATUM650 QUED LMT =
ATUM650 DISCARDED FID4S RXD= XMT=
```

Explanation: NTuneMON display for PA2=LOG from the ATUML Multi-Link Transmission Group panel.

User Response: See “ATUML Multi-Link Transmission Group Panel” on page 4-184 for more information.

ATUM652

```

ATUM652 HPR FLOW CONTROL
ATUM652 HPRSMPSE = 0
ATUM652 HPRSATT = 2000
ATUM652 HPRSMLC = 9
```

Explanation: NTuneMON display for PA2=LOG from the ATUHP HPR & Other Global Flow Control Params panel.

User Response: See “ATUHP HPR & Other Global Flow Control Params Panel” on page 4-153 for more information.

ATUM660

```

ATUM660 X.25 MCH Physical Line List
ATUM699
ATUM699 (variable data)
ATUM699
:
```

Explanation: NTuneMON display for PA2=Log from the ATUXL X.25 MCH Physical Line List panel.

User Response: See “ATUXL X.25 MCH Physical Line List Panel” on page 4-350 for more information.

ATUM661

```

ATUM661 X.25 MCH VCCPT Information
ATUM699
ATUM699 (variable data)
ATUM699
:
```

Explanation: NTuneMON display for PA2=Log from the ATUXX X.25 VCCPT Information panel.

User Response: See “ATUXX X.25 VCCPT Information Panel” on page 4-369 for more information.

ATUM662

```

ATUM662 X.25 MCH Physical Line Details Pg1
ATUM699
ATUM699      (variable data)
ATUM699
:
```

Explanation: NTuneMON display for PA2=Log from the ATUXP X.25 MCH Physical Line Details Page 1 panel.

User Response: See “ATUXP X.25 MCH Physical Line Details Page 1 Panel” on page 4-353 for more information.

ATUM663

```

ATUM663 X.25 MCH Physical Line Details Pg2
ATUM699
ATUM699      (variable data)
ATUM699
:
```

Explanation: NTuneMON display for PA2=Log from the ATUXS X.25 MCH Physical Line Details Page 2 panel.

User Response: See “ATUXS X.25 MCH Physical Line Details Page 2 Panel” on page 4-362 for more information.

ATUM664

```

ATUM664 MCH Physical Line Statistics
ATUM699
ATUM699      (variable data)
ATUM699
:
```

Explanation: NTuneMON display for PA2=Log from the ATUXH X.25 MCH Physical Line Statistics panel.

User Response: See “ATUXH X.25 MCH Physical Line Statistics Panel” on page 4-348 for more information.

ATUM665

```

ATUM665 X.25 Virtual Circuit List
ATUM699
ATUM699      (variable data)
ATUM699
:
```

Explanation: NTuneMON display for PA2=Log from the ATUXV X.25 Virtual Circuit List panel.

User Response: See “ATUXV X.25 Virtual Circuit List Panel” on page 4-366 for more information.

ATUM666

```

ATUM666 X.25 Virtual Circuit Details
ATUM699
ATUM699      (variable data)
ATUM699
:
```

Explanation: NTuneMON display for PA2=Log from the ATUXD X.25 Virtual Circuit Details panel.

User Response: See “ATUXD X.25 Virtual Circuit Details Panel” on page 4-341 for more information.

ATUM667

```

ATUM667 Virtual Circuit Statistics
ATUM699
ATUM699      (variable data)
ATUM699
      :
```

Explanation: NTuneMON display for PA2=Log from the ATUXF NPSI Virtual Circuit Statistics panel.

User Response: See “ATUXF NPSI Virtual Circuit Statistics Panel” on page 4-346 for more information.

ATUM670

```

ATUM670 ISDN Physical Line List
ATUM699
ATUM699      (variable data)
ATUM699
      :
```

Explanation: NTuneMON display for PA2=Log from the ATUDL ISDN Physical Line Table panel.

User Response: See “ATUDL ISDN Physical Line Table Panel” on page 4-59 for more information.

ATUM671

```

ATUM671 ISDN Physical Line Details
ATUM570 NCP2762 FRAME RELAY LINE ADDR=24 STATUS=ACTIVE
ATUM571 LINE NAME=T02724L SPEED=N/A TYPE=TSS Full Duplex
ATUM699
ATUM572 FRAME STATISTICS TRANSMITTED RECEIVED MAXFRAME=2106
ATUM699      (variable data)
ATUM699
      :
```

Explanation: NTuneMON display for PA2=Log from the ATUDK ISDN Physical Line Details panel.

User Response: See “ATUDK ISDN Physical Line Details Panel” on page 4-49 for more information.

ATUM672

```

ATUM672 ISDN B-Channel Line List
ATUM699
ATUM699      (variable data)
ATUM699
      :
```

Explanation: NTuneMON display for PA2=Log from the ATUDM ISDN B-Channel Line Table panel.

User Response: See “ATUDM ISDN B-Channel Line Table Panel” on page 4-62 for more information.

ATUM673

```

ATUM673 ISDN B-Channel Line Details
ATUM570 NCP2762 FRAME RELAY LINE ADDR=24 STATUS=ACTIVE
ATUM699
ATUM699 (variable data)
ATUM699
:
```

Explanation: NTuneMON display for PA2=LOG from the ATUDN ISDN B-Channel Line Details panel.

User Response: See “ATUDN ISDN B-Channel Line Details Panel” on page 4-65 for more information.

ATUM674

```

ATUM674 ISDN Station List
ATUM699
ATUM699 (variable data)
ATUM699
:
```

Explanation: NTuneMON display for PA2=Log from the ATUDS ISDN Stations Table List panel.

User Response: See “ATUDS ISDN Stations Table List Panel” on page 4-71 for more information.

ATUM675

```

ATUM675 ISDN Station Details
ATUM593 ADDR=- NAME=A04P00A TYPE=T5 STATUS=ACTIVE
ATUM699
ATUM699 (variable data)
ATUM699
:
```

Explanation: NTuneMON display for PA2=Log from the ATUDT ISDN Station Details panel.

User Response: See “ATUDT ISDN Station Details Panel” on page 4-73 for more information.

List of Abbreviations

ACF	Advanced Communications Function	DR	dynamic reconfiguration
ACF/NCP	Advanced Communications Function for the Network Control Program	DSAP	destination service access point
ACF/SSP	Advanced Communications Function for the System Support Programs	DTE	data terminal equipment
ACF/VTAM	Advanced Communications Function for the Virtual Telecommunications Access Method	DTG	date and time generation
ACTLINK	activate link	EBCDIC	extended binary-coded decimal interchange code
ACU	automatic calling unit	EC	engineering change
AIT	adapter information table	ECT	Ethernet statistical counter
ANR	automatic network routing	EP	Emulation Program
ANS	automatic network shutdown	ER	explicit route
ANSI	American National Standards Institute	ERP	error recovery procedures
APAR	authorized program analysis report	ESCON	Enterprise Systems Connection
ARP	Address Resolution Protocol	ESS	Ethernet-type subsystem
ATE	ARP table entry	FTPI	Fast Transaction Processing Interface
BAN	boundary access node	FC	flow control
BECN	backward explicit congestion notification	FDX	full-duplex
BPOOL	destination buffer boundary pool	FECN	forward explicit congestion notification
BSB	boundary session control block	FFDC	first-failure data capture
CAB	channel adapter control block	FH	frame handler
CB	control block	FHSP	frame handler subport
CCITT	International Telegraph and Telephone Consultative Committee	FRFH	frame-relay frame handler
CCU	central control unit	FRSE	frame-relay switching equipment
CDS	configuration data set	FRTE	frame-relay terminating equipment
CLP	communication line processor	GWNAU	gateway network addressable units
CMS	conversational monitor system	HD	half-duplex
CP	(1) control point (2) control program	HDX	half-duplex
CPS	call progress signal	HPR	high-performance routing
CPU	central processing unit	HPTSS	high-performance transmission system
CRC	cyclic redundancy check	HRE	host route entry
CSS	connectivity subsystem	HSCB	half-session control blocks
CTS	clear to send	I/O	input/output
CUB	common physical unit blocks	ICMP	Internet Control Message Protocol
DACTLINK	deactivate link	IEEE	Institute of Electrical and Electronics Engineers
DCE	data circuit-terminating equipment	INOP	declare inoperative
DE	discard eligible	IP	Internet Protocol
DLCI	data link connection identifier	IPS	Internet Protocol router statistics
DPU	dynamic path update	IPSP	IP subport
		ISDN	integrated services digital network

Abbreviations

ITU	International Telecommunication Union	NPA	network performance analyzer
JCL	job control language	NPDA	Network Problem Determination Application
Kbps	kilobits per second	NPM	NetView Performance Monitor
LAC	line access control	NPSI	X.25 NCP Packet Switching Interface
LAE	local address entry	NRE	network route entry
LAN	local area network	NRZ	non-return-to-zero recording
LCN	logical channel number	NRZI	non-return-to-zero (inverted) recording
LIV	link integrity verification	NRZ-1	non-return-to-zero change-on-ones recording
LIVT	link integrity verification tests	NSA	NPA session accounting
LKB	line control block	NSI	Non-SNA Interconnection
LLB	logical link control block	NSP	NPA session processing
LLC	logical link control	NTRI	NCP/Token-Ring interconnection
LL2	Link level 2	NVT	network vector table
LMI	local management interface	ODLC	outboard data link control
LOBQ	link outbound queue	OLT	online line testing
LPDA	Link Problem Determination Aid	PAB	process anchor block
LU	logical unit	PEP	partitioned emulation programming
MAC	medium access control	PF	program function
Mbps	megabits per second	PIU	path information unit
MCH	multichannel	PLB	presentation services local block
MIB	(1) Management Information Base (2) MIB module	PLU	primary logical unit
MLTG	multilink transmission group	PMF	performance measurement facility
MMMLTG	mixed media multilink transmission group	PSA	parameter status area
MOSS	maintenance and operator subsystem	PTF	program temporary fix
ms	milliseconds	PU	physical unit
MTU	maximum transfer unit	PUDR	physical unit dynamic reconfiguration
MVS	Multiple Virtual Storage	PVC	permanent virtual circuit
MVS/ESA	Multiple Virtual Storage/Enterprise Systems Architecture	QAB	queue anchor block
NACK	not acknowledged	QAN	queue anchor block for network
NAU	(1) network accessible unit (2) network addressable unit	RDI	restricted digital information
NCCF	Network Communication Control Facility	REX	route extension
NCP	Network Control Program	REXX	Restructured Extended Executor
NCST	NCP connectionless SNA transport	RNR	receive not ready
NDF	NCP/EP definition facility	RR	receive ready
NEO	NCP Extension Option	RTS	request to send
NETID	network identifier	RWI	reset window indicator
NIB	node initialization block	SAP	service access point
NMVT	network management vector transport	SCB	station control block
NNT	network names table	SCE	station control block extension
		SDLC	Synchronous Data Link Control
		SDS	shared data store

SNA	Systems Network Architecture	TGB	transmission group control block
snap	snapshot program	TGN	transmission group number
SNI	SNA network interconnection	TIC	Token-Ring interface coupler
SNMP	Simple Network Management Protocol	TPS	two-processor switch
SNQ	ODLC/NMVT queue	TSS	transmission subsystem
SOT	service order table	TVS	time value select
SRE	subnetwork route entry	UDI	unrestricted digital information
SS	start-stop	UDP	User Datagram Protocol
SSAP	source service access point	VC	virtual circuit
SSB	system status block	VCCPT	Virtual circuit connection parameter table
SSCP	system services control point	VM	Virtual Machine
SSP	system support Program	VM/ESA	Virtual Machine/Enterprise Systems Architecture
SVC	(1) supervisor call (2) switched virtual circuit	VR	virtual route
TAB	terminal anchor block	VRB	virtual route control block
TCP/IP	Transmission Control Program/Internet Protocol	WW	working window
TESP	terminating equipment support	XID	exchange identification
TG	transmission group	XMIT	transmit
		XRF	extended recovery facility

Glossary

This glossary includes terms and definitions from:

- The *American National Standard Dictionary for Information Systems*, ANSI X3.172-1990, copyright 1990 by the American National Standards Institute (ANSI). Copies can be purchased from the American National Standards Institute, 11 West 42nd Street, New York, New York 10036. Definitions are identified by the symbol (A) after the definition.
- The ANSI/EIA Standard—440-A, *Fiber Optic Terminology*. Copies may be purchased from the Electronic Industries Association, 2001 Pennsylvania Avenue, N.W., Washington, DC 20006. Definitions are identified by the symbol (E) after the definition.
- The *Information Technology Vocabulary*, developed by Subcommittee 1, Joint Technical Committee 1, of the International Organization for Standardization and the International Electrotechnical Commission (ISO/IEC JTC1/SC1). Definitions of published parts of this vocabulary are identified by the symbol (I) after the definition; definitions taken from draft international standards, committee drafts, and working papers being developed by ISO/IEC JTC1/SC1 are identified by the symbol (T) after the definition, indicating that final agreement has not yet been reached among the participating National Bodies of SC1.
- The *IBM Dictionary of Computing*, New York: McGraw-Hill, 1994.
- Internet Request for Comments: 1208, *Glossary of Networking Terms*.
- Internet Request for Comments: 1392, *Internet Users' Glossary*.
- The *Object-Oriented Interface Design: IBM Common User Access Guidelines*, Carmel, Indiana: Que, 1992.

The following cross-references are used in this glossary:

Contrast with: This refers to a term that has an opposed or substantively different meaning.

Synonym for: This indicates that the term has the same meaning as a preferred term, which is defined in its proper place in the glossary.

Synonymous with: This is a reference from a defined term to other terms that have the same meaning.

See: This refers the reader to the spelled-out form of the term or to a more common spelling of the term.

See also: This refers the reader to terms that have a related, but not synonymous, meaning.

Refer to “List of Abbreviations” on page X-1 for the meanings of abbreviations that do not appear in this glossary.

A

ACF. See *Advanced Communications Function*

ACF/NCP. Synonym for *Network Control Program (NCP)*.

ACF/SSP. Synonym for *System Support Programs (SSP)*.

ACF/VTAM. Synonym for *Virtual Telecommunications Access Method (VTAM)*.

acknowledgment. (1) The transmission, by a receiver, of acknowledge characters as an affirmative response to a sender. (T) (2) An indication that an item sent was received.

ACU. See *automatic calling unit*.

adapter. A part that electrically or physically connects a device to a computer or to another device.

Address Resolution Protocol (ARP). In the Internet suite of protocols, the protocol that dynamically maps an IP address to an address used by a supporting metropolitan or local area network such as Ethernet or Token-Ring.

Advanced Communications Function (ACF). A group of IBM licensed programs, principally VTAM, TCAM, NCP, and SSP, that use the concepts of Systems Network Architecture (SNA), including distribution of function and resource sharing.

alert. (1) A message sent to a management services focal point in a network to identify a problem or an impending problem. (2) In SNA management services (SNA/MS), a high priority event that warrants immediate attention.

American National Standards Institute (ANSI). An organization consisting of producers, consumers, and general interest groups, that establishes the procedures by which accredited organizations create and maintain voluntary industry standards in the United States. (A)

ANSI. See *American National Standards Institute*.

APAR. See *authorized program analysis report*.

ARP. See *Address Resolution Protocol*.

Glossary

authorized program analysis report (APAR). A report of a problem caused by a suspected defect in a current unaltered release of a program.

automatic calling unit (ACU). A dialing device that permits a computer to automatically dial calls over a network.

autotask. An unattended NetView operator station task that does not require a terminal or a logged-on user. Autotasks can run independently of VTAM and are typically used for automated console operations.

B

B-channel. In the integrated services digital network (ISDN), a 64 kilobits-per-second channel for the transport of speech or data between the ISDN service provider and user.

beacon frame. A frame sent by an adapter indicating a serious ring problem, such as a broken cable. An adapter is "beaconing" if it is sending such a frame.

binary synchronous transmission. Data transmission in which synchronization of characters is controlled by timing signals generated at the sending and receiving stations. Contrast with *start-stop (SS) transmission* and *Synchronous Data Link Control (SDLC)*.

boundary access node (BAN). A router (such as the IBM 6611) that provides its attached LAN-based SNA peripheral nodes direct frame-relay access to a subarea boundary node (such as an IBM 3745 or an IBM 3746 Model 900).

bridge. (1) A functional unit that interconnects two local area networks that use the same logical link control protocol but may use different medium access control protocols. (T) (2) A functional unit that interconnects multiple LANs (locally or remotely) that use the same logical link control protocol but that can use different medium access control protocols. A bridge forwards a frame to another bridge based on the medium access control (MAC) address. (3) In the connection of local loops, channels, or rings, the equipment and techniques used to match circuits and to facilitate accurate data transmission.

buffer. A portion of storage used to hold input or output data temporarily.

C

canonical address. In LANs, the IEEE 802.1 format for the transmission of medium access control (MAC) addresses for Token-Ring and Ethernet adapters. In canonical format, the least significant (rightmost) bit of each address byte is transmitted first. Contrast with *noncanonical address*.

CCITT. International Telegraph and Telephone Consultative Committee. This was an organization of the International Telecommunication Union (ITU). On 1 March 1993 the ITU was reorganized, and responsibilities for standardization were placed in a subordinate organization named the Telecommunication Standardization Sector of the International Telecommunication Union (ITU-TS). "CCITT" continues to be used for recommendations that were approved before the reorganization.

central processing unit (CPU). The part of a computer that includes the circuits that control the interpretation and execution of instructions.

Note: A CPU is the circuitry and storage that executes instructions. Traditionally, the complete processing unit was often regarded as the CPU, whereas today the CPU is often a microchip. In either case, the centrality of a processor or processing unit depends on the configuration of the system or network in which it is used.

channel adapter. A communication controller hardware unit that is used to attach the communication controller to a host channel.

channel link. A System/370 I/O channel to control unit interface that has an SNA network address. A channel link can be either a subarea link or a peripheral link and is defined in an NCP generation definition using the GROUP, LINE, and PU definition statements.

checksum. In error detection, a function of all bits in a block. If the written and calculated sums do not agree, an error is indicated.

clear to send (CTS). In data communication, a signal raised by data circuit-terminating equipment (DCE) when it is ready to accept data, usually in response to request to send (RTS) being raised.

clocking. A method of controlling the number of data bits sent on a telecommunication line in a given time.

CLP. See *communication line processor*.

CMS. See *conversational monitor system*.

collision. An unwanted condition that results from concurrent transmissions on a channel. (T)

communication adapter. A circuit card with associated software that enables a processor, controller, or other device to be connected to a network.

communication controller. A type of communication control unit whose operations are controlled by one or more programs stored and executed in the unit. It manages the details of line control and the routing of data through a network.

communication line processor (CLP). In a communication controller, the processor that manages telecommunication lines.

congestion. Synonym for *network congestion*.

connectivity subsystem (CSS). An expansion frame, such as the 3746 Model 900, that extends connectivity and enhances the performance of the IBM 3745 Communication Controller.

control block. A storage area used by a computer program to hold control information. (I)

control point (CP). (1) A component of an APPN or LEN node that manages the resources of that node. In an APPN node, the CP is capable of engaging in CP-CP sessions with other APPN nodes. In an APPN network node, the CP also provides services to adjacent end nodes in the APPN network. (2) A component of a node that manages resources of that node and optionally provides services to other nodes in the network. Examples are a system services control point (SSCP) in a type 5 subarea node, a network node control point (NNCP) in an APPN network node, and an end node control point (ENCP) in an APPN or LEN end node. An SSCP and an NNCP can provide services to other nodes.

control program. (1) A computer program designed to schedule and to supervise the execution of programs of a computer system. (I) (A) (2) In VM/ESA, synonym for *Control Program (CP)*.

Control Program (CP). In VM/ESA, a component that manages the resources of a single computer so multiple computing systems appear to exist. Each of these apparent systems, or virtual machines, is the functional equivalent of an IBM System/370, 370-XA, or ESA computer.

conversational monitor system (CMS). A virtual machine operating system that provides general interactive time sharing, problem solving, and program development capabilities, and operates only under control of the VM control program.

CP. See *control point, control program*.

CPU. See *central processing unit*.

CRC. The cyclic redundancy check character. (A)

cross-network. In SNA, pertaining to control or resources involving more than one network.

CSS. See *connectivity subsystem*.

CTS. See *clear to send*.

CWALL. An NCP threshold of buffer availability, below which the NCP will accept only high-priority path information units (PIUs).

cyclic redundancy check (CRC). (1) A redundancy check in which the check key is generated by a cyclic algorithm. (T) (2) A system of error checking performed at both the sending and receiving station after a block check character has been accumulated.

D

data link connection identifier (DLCI). The numeric identifier of a frame-relay subport or PVC segment in a frame-relay network. Each subport in a single frame-relay port has a unique DLCI. The following table, excerpted from the American National Standards Institute (ANSI) Standard T1.618 and the International Telegraph and Telephone Consultative Committee (CCITT) Standard Q.922, indicates the functions associated with certain DLCI values:

DLCI Values	Function
0	in-channel signaling
1–15	reserved
16–991	assigned using frame-relay connection procedures
992–1007	layer 2 management of frame-relay bearer service
1008–1022	reserved
1023	in-channel layer management

data stream. (1) All information (data and control commands) sent over a data link usually in a single read or write operation. (2) A continuous stream of data elements being transmitted, or intended for transmission, in character or binary-digit form, using a defined format.

data terminal equipment (DTE). That part of a data station that serves as a data source, data sink, or both. (I) (A)

data transfer rate. The average number of bits, characters, or blocks per unit time passing between corresponding equipment in a data transmission system. (I)

Glossary

Notes:

1. The rate is expressed in bits, characters, or blocks per second, minute, or hour.
2. Corresponding equipment should be indicated; for example, modems, intermediate equipment, or source and sink.

datagram. In TCP/IP, the basic unit of information passed across the Internet environment. A datagram contains a source and destination address along with the data. An Internet Protocol (IP) datagram consists of an IP header followed by the transport layer data.

definition statement. (1) In VTAM, the statement that describes an element of the network. (2) In NCP, a type of instruction that defines a resource to the NCP. See Figure X-1, Figure X-2, and Figure X-3.

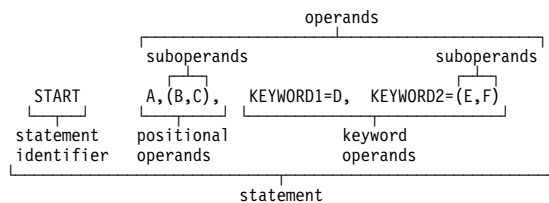

Figure X-1. Example of a Language Statement

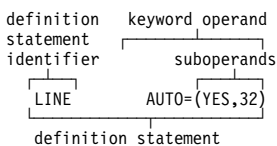

Figure X-2. Example of an NCP Definition Statement

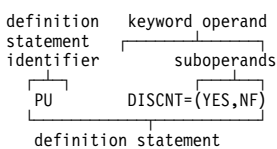

Figure X-3. Example of a VTAM Definition Statement

destination port. The 8-port asynchronous adapter that serves as a connection point with a serial service.

destination service access point (DSAP). In SNA and TCP/IP, a logical address that allows a system to route data from a remote device to the appropriate communications support. Contrast with *source service access point (SSAP)*.

DLCI. See *data link connection identifier*.

downstream. In the direction of data flow from the host to the end user. Contrast with *upstream*.

DSAP. See *destination service access point*.

DTE. See *data terminal equipment*. (A)

duplex. Pertaining to communication in which data can be sent and received at the same time. Synonymous with *full-duplex*. Contrast with *half-duplex*.

dynamic path update. The process of changing the network path for sending information without regenerating complete configuration tables.

dynamic reconfiguration (DR). The process of changing the network configuration (peripheral PUs and LUs) without regenerating complete configuration tables or deactivating the affected major node.

E

EBCDIC. Extended binary-coded decimal interchange code. A coded character set of 256 8-bit characters.

Emulation Program (EP). An IBM control program that allows a channel-attached IBM communication controller to emulate the functions of an IBM 2701 Data Adapter Unit, an IBM 2702 Transmission Control, or an IBM 2703 Transmission Control.

endpoint node. A node that is at the end of only one branch. Synonymous with *peripheral node*. (T)

EP. See *Emulation Program*.

ER. See *explicit route*.

ERP. See *error recovery procedures*.

error recovery procedures (ERP). (1) Procedures designed to help isolate and, where possible, to recover from errors in equipment. The procedures are often used in conjunction with programs that record information on machine malfunctions. (2) A set of routines that attempt to recover from transmission errors.

Enterprise Systems Connection (ESCON). A set of IBM products and services that provide a dynamically connected environment within an enterprise.

ESCON. See *Enterprise Systems Connection*.

Ethernet. A 10-Mbps baseband local area network that allows multiple stations to access the transmission medium at will without prior coordination, avoids contention by using carrier sense and deference, and resolves contention by using collision detection and delayed retransmission. Ethernet uses carrier sense multiple access with collision detection (CSMA/CD).

Ethernet-type LAN. A local area network that uses either the Ethernet Version 2 or IEEE 802.3 protocol.

exchange identification (XID). A specific type of basic link unit that is used to convey node and link characteristics between adjacent nodes. XIDs are exchanged between link stations before and during link activation to establish and negotiate link and node characteristics, and after link activation to communicate changes in these characteristics.

explicit route (ER). In SNA, a series of one or more transmission groups that connect two subarea nodes. An explicit route is identified by an origin subarea address, a destination subarea address, an explicit route number, and a reverse explicit route number. Contrast with *virtual route (VR)*.

extended recovery facility (XRF). A facility that minimizes the effect of failures in MVS, VTAM, the host processor, or high availability applications during sessions between high availability applications and designated terminals. This facility provides an alternate subsystem to take over sessions from the failing subsystem.

F

FDX. See *full-duplex*.

FH. See *frame handler*.

FHSP. See *frame handler subport*.

flow control. (1) In data communication, control of the data transfer rate. (l) (2) In SNA, the process of managing the rate at which data traffic passes between components of the network. The purpose of flow control is to optimize the rate of flow of message units with minimum congestion in the network; that is, to neither overflow the buffers at the receiver or at intermediate routing nodes, nor leave the receiver waiting for more message units. See also *pacing*.

fragmentation. The process of dividing a datagram into smaller parts, or fragments, to match the capabilities of the physical medium over which it is to be transmitted.

frame. The unit of transmission in some local area networks, including the IBM Token-Ring Network. It includes delimiters, control characters, information, and checking characters.

frame handler (FH). Synonym for *frame-relay frame handler (FRFH)*.

frame handler subport (FHSP). The access point of a frame-relay frame handler to a PVC segment. Frame handler subports function in pairs; frames enter the frame handler through one frame handler subport and exit through the other. Contrast with *terminating equipment subport*.

frame relay. (1) An interface standard describing the boundary between a user's equipment and a fast-packet network. In frame-relay systems, flawed frames are discarded; recovery comes end-to-end rather than hop-by-hop. (2) A technique derived from the integrated services digital network (ISDN) D channel standard. It assumes that connections are reliable and dispenses with the overhead of error detection and control within the network.

frame-relay frame handler (FRFH). The function in a frame-relay node that routes (or switches) frames along a permanent virtual circuit (PVC). A frame handler receives frames from an adjacent frame-relay node and uses the DLCI to forward them to the next node on the PVC. Synonymous with *frame handler*. See also *frame-relay switching equipment support* and *frame-relay terminating equipment*.

frame-relay network. A network that consists of frame-relay frame handlers (FRFH) and in which frames are passed from one frame-relay terminating equipment (FRTE) station to another through a series of one or more FRFHs.

frame-relay switch. A frame-relay node that provides both the frame-relay frame handler function and the local management interface (LMI) function.

frame-relay switching equipment (FRSE). Synonym for *frame-relay switching equipment (FRSE) support*.

frame-relay switching equipment (FRSE) support set. The set of primary and, optionally, substitute frame handler subports (FHSPs) within an NCP that comprise those used for a given frame-relay segment set.

frame-relay switching equipment (FRSE) support. In NCP, a set of frame-relay functions that include the frame-relay frame handler function and the local management interface (LMI) function. These functions are defined by American National Standards Institute (ANSI) Standards T1.617 and T1.618 and International Telegraph and Telephone Consultative Committee (CCITT) Standards Q.922 and Q.933. NCP provides additional functions, including performance measurement and enhanced reliability, that are not defined by ANSI or CCITT standards.

frame-relay terminal equipment. A device that can connect to a frame-relay network and provide the frame-relay terminating equipment function. See also *frame-relay frame handler* and *frame-relay terminating equipment*.

frame-relay terminating equipment (FRTE). The function at the end of a frame-relay permanent virtual circuit (PVC). Frame-relay terminating equipment pro-

Glossary

vides higher-layer protocols with access to a frame-relay network through terminating equipment supports (TESPs). It does this by (a) adding frame-relay frame headers to data for another protocol and sending the frames to adjacent frame-relay nodes, and (b) receiving frames from adjacent frame-relay nodes and removing the frame headers. See also *frame-relay frame handler*, *frame-relay switching equipment support*, and *frame-relay terminal equipment*.

FRFH. See *frame-relay frame handler*.

FRSE. See *frame-relay switching equipment*.

FRTE. See *frame-relay terminating equipment*.

full-duplex (FDX). Synonym for *duplex*.

fully qualified name. In SNA, synonym for *network-qualified name*.

G

gateway. A functional unit that interconnects two computer networks with different network architectures. A gateway connects networks or systems of different architectures. A bridge interconnects networks or systems with the same or similar architectures. (T)

gateway NCP. An NCP that performs address translation to allow cross-network session traffic. The gateway NCP connects two or more independent SNA networks.

generic alert. A product-independent method of encoding alert data by means of both (a) code points indexing short units of stored text and (b) textual data.

granularity. The extent to which a larger entity is subdivided. For example, a yard divided into inches has finer granularity than a yard divided into feet.

H

half-duplex (HD, HDX). In data communication, pertaining to transmission in only one direction at a time. Contrast with *duplex*.

HD. See *half-duplex*.

HDX. See *half-duplex*.

high-performance routing (HPR). An addition to APPN that enhances data-routing performance and session reliability.

high-performance transmission subsystem (HPTSS). A high-speed line adapter that attaches to the IBM 3745 Communication Controller.

hop count. (1) A metric or measure of distance between two points. (2) In Internet communications, the number of routers that a datagram passes through on its way to its destination. (3) In SNA, a measure of the number of links to be traversed in a path to a destination.

hot standby. In computer security, pertaining to the immediate readiness of a functional unit to which operations can be readily switched.

HPR. See *high-performance routing*.

HPTSS. See *high-performance transmission subsystem*.

I

I-frame. See *information (I) frame*.

ICMP. See *Internet Control Message Protocol*.

information (I) frame. A frame in I format used for numbered information transfer.

integrated services digital network (ISDN). A digital end-to-end telecommunication network that supports multiple services including, but not limited to, voice and data.

Note: ISDNs are used in public and private network architectures.

International Telecommunication Union (ITU). The specialized telecommunication agency of the United Nations, established to provide standardized communication procedures and practices, including frequency allocation and radio regulations worldwide.

internet. A collection of networks interconnected by a set of routers that allow them to function as a single, large network. See also *Internet*.

Internet. The internet administered by the Internet Architecture Board (IAB), consisting of large national backbone networks and many regional and campus networks all over the world. The Internet uses the Internet suite of protocols.

Internet Control Message Protocol (ICMP). The protocol used to handle errors and control messages in the Internet Protocol (IP) layer. Reports of problems and incorrect datagram destinations are returned to the original datagram source. ICMP is part of the Internet Protocol.

Internet Protocol (IP). A connectionless protocol that routes data through a network or interconnected networks. IP acts as an intermediary between the higher protocol layers and the physical network. However, this

protocol does not provide error recovery and flow control and does not guarantee the reliability of the physical network.

IP. See *Internet Protocol*.

ITU. See *International Telecommunication Union*.

ITU-TS. International Telecommunication Union - Telecommunication Standardization Sector. The part of the International Telecommunication Union (ITU) that is responsible for developing recommendations for telecommunications.

K

keyword. (1) The part of a command operand that consists of a specific character string (such as `DSNAME=`). (2) See also *definition statement* and *keyword operand*.

keyword operand. An operand that consists of a keyword followed by one or more values (such as `DSNAME=HELLO`). See also *definition statement*.

L

LAN. See *local area network*.

LAN segment. (1) Any portion of a LAN (for example, a bus or ring) that can operate independently, but that is connected to other parts of the network by means of bridges. (2) A ring or bus network without bridges.

line. (1) The portion of a data circuit external to data circuit-terminating equipment (DCE), that connects the DCE to a data switching exchange (DSE), that connects a DCE to one or more other DCEs, or that connects a DSE to another DSE. (l) (2) See also *logical line*, *physical line*, *spare line*, *switched line*.

line speed. The number of binary digits that can be sent over a telecommunication line in one second, expressed in bits per second (bps).

link integrity verification tests (LIVT). A set of operational procedures and messages that is defined by American National Standards Institute (ANSI) Standard T1.617 Annex D and International Telegraph and Telephone Consultative Committee (CCITT) Standard Q.933 Annex A and that is transferred over DLCI 0. This set of operational procedures and messages provides status and outage notification for frame-relay frame handler (FRFH) and frame-relay terminating equipment (FRTE) connections. See also *local management interface (LMI)*.

Link Problem Determination Aid (LPDA). A series of procedures that are used to test the status of and to control DCEs, the communication line, and the remote

device interface. These procedures, or a subset of them, are implemented by host programs (such as the NetView program and VTAM), communication controller programs (such as NCP), and IBM LPDA DCEs. See also *LPDA-1* and *LPDA-2*.

link station. The hardware and software components within a node representing a connection to an adjacent node over a specific link. For example, if node A is the primary end of a multipoint line that connects to three adjacent nodes, node A will have three link stations representing the connections to the adjacent nodes.

LIVT. See *link integrity verification tests*.

LLC. See *logical link control (LLC) protocol*.

LMI. See *local management interface*.

LMI support. A frame-relay support that exchanges line status information with adjacent nodes using local management interface (LMI) protocol. In NCP, the LMI support is the link-station support for the physical line.

local area network (LAN). A computer network located on a user's premises within a limited geographical area. Communication within a local area network is not subject to external regulations; however, communication across the LAN boundary may be subject to some form of regulation. (T)

local management interface (LMI). Synonym for *local management interface (LMI) protocol*.

local management interface (LMI) protocol. (1) In NCP, a set of frame-relay network management procedures and messages used by adjacent frame-relay nodes to exchange line status information over DLCI X'00'. NCP supports both the American National Standards Institute (ANSI) and International Telegraph and Telephone Consultative Committee (CCITT) versions of LMI protocol. These standards refer to LMI protocol as *link integrity verification tests (LIVT)*. (2) Originally, a set of frame-relay network management procedures and messages used by frame-relay nodes to exchange line status information over DLCI X'03FF' (1023). This protocol is defined in *Frame-Relay Specification with Extensions*, a document based on proposed T1S1 standards, which are copyrighted by Digital Equipment Corporation, Northern Telecom, Inc., and StrataCom, Inc. This protocol is not compatible with the ANSI or CCITT version. In this context, the term *local management interface* is a synonym for *link integrity verification tests (LIVT)*.

logical line. In NCP, the representation of the connection between NCP and a node communicating with NCP over a physical line such as Token-Ring or frame-relay. A single physical line can support multiple logical lines. Contrast with *physical line*.

Glossary

logical link control (LLC) protocol. In a local area network, the protocol that governs the exchange of transmission frames between data stations independently of how the transmission medium is shared. (T) The LLC protocol was developed by the IEEE 802 committee and is common to all LAN standards.

logical unit (LU). A type of network accessible unit that enables end users to gain access to network resources and communicate with each other.

LPDA. See *Link Problem Determination Aid*.

LPDA-1. The first version of the LPDA command set. LPDA-1 is not compatible with LPDA-2. See also *Link Problem Determination Aid (LPDA)* and *LPDA-2*.

LPDA-2. The second version of the LPDA command set. LPDA-2 provides all of the functions of LPDA-1; it also supports commands such as the following:

- DCE configuration
- Dial
- Set transmit speed
- Commands to operate a contact that can control external devices.

See also *Link Problem Determination Aid (LPDA)* and *LPDA-1*.

LU. See *logical unit*.

LU-LU session. A logical connection between two logical units (LUs) in an SNA network that typically provides communication between two end users.

M

MAC. See *medium access control*.

MAC frame. A transmission frame that controls the operation of the IBM Token-Ring Network and any ring station operations that affect the ring.

maintenance and operator subsystem (MOSS). A subsystem of an IBM communication controller, such as the 3725 or the 3720, that contains a processor and operates independently of the rest of the controller. It loads and supervises the controller, runs problem determination procedures, and assists in maintaining both hardware and software.

major node. In VTAM, a set of resources that can be activated and deactivated as a group. Contrast with *minor node*.

Management Information Base (MIB). (1) A collection of objects that can be accessed by means of a network management protocol. (2) A definition for management information that specifies the information

available from a host or gateway and the operations allowed. (3) In OSI, the conceptual repository of management information within an open system.

maximum transfer unit (MTU). The maximum number of bytes that an Internet Protocol (IP) datagram can contain.

medium access control (MAC). In LANs, the sublayer of the data link control layer that supports medium-dependent functions and uses the services of the physical layer to provide services to the logical link control (LLC) sublayer. The MAC sublayer includes the method of determining when a device has access to the transmission medium.

metric. In Internet communications, a value, associated with a route, which is used to discriminate between multiple exit or entry points to the same autonomous system. The route with the lowest metric is preferred.

MIB. (1) MIB module. (2) See *Management Information Base*.

minor node. In VTAM, a uniquely defined resource within a major node. Contrast with *major node*. See also *node*.

MLTG. Multilink transmission group. See *transmission group*.

MMMLTG. Mixed-media multilink transmission group.

modem (modulator/demodulator). (1) A functional unit that modulates and demodulates signals. One of the functions of a modem is to enable digital data to be transmitted over analog transmission facilities. (T) (A) (2) A device that converts digital data from a computer to an analog signal that can be transmitted on a telecommunication line, and converts the analog signal received to data for the computer.

modulo. (1) Pertaining to a modulus; for example, 9 is equivalent to 4 modulo 5. (2) See also *modulus*.

modulus. A number, such as a positive integer, in a relationship that divides the difference between two related numbers without leaving a remainder; for example, 9 and 4 have a modulus of 5 ($9 - 4 = 5$; $4 - 9 = -5$; and 5 divides both 5 and -5 without leaving a remainder).

MOSS. See *maintenance and operator subsystem*.

MTU. See *maximum transfer unit*.

multilink transmission group (MLTG). Synonym for *transmission group (TG)*.

Multiple Virtual Storage (MVS). Synonym for *MVS*.

MVS. Multiple Virtual Storage. Implies MVS/ESA and OS/390.

N

native network. The subnetwork whose network identifier a node uses for its own network-qualified resource names.

NAU. (1) See *network accessible unit*. (2) See *network addressable unit*.

NCCF. (1) Network Communications Control Facility. (2) A command that starts the NetView command facility. NCCF also identifies various panels and functions as part of the command facility.

NCP. See *Network Control Program*.

NCP connectionless SNA transport (NCST). A function that allows NCP to transfer TCP/IP frames across the SNA subarea routing network. The NCST session interface provides access to an LU-LU session that can transport Internet Protocol (IP) datagrams to a host that uses the SNA Network Link (SNALINK) or to another NCP that uses NCST.

NCP/EP definition facility (NDF). A program that is part of System Support Programs (SSP) and that is used to generate a load module for a partitioned emulation program (PEP), a Network Control Program (NCP), or an Emulation Program (EP).

NCP/Token-Ring interconnection (NTRI). An NCP function that allows a communication controller to attach to the IBM Token-Ring Network and that provides both subarea and peripheral node data link control (DLC) services in the SNA network.

NCST. See *NCP connectionless SNA transport*.

NDF. See *NCP/EP definition facility*.

NETID. See *network identifier*.

NetView Performance Monitor (NPM). An IBM licensed program that collects, monitors, analyzes, and displays data relevant to the performance of a VTAM telecommunication network. It runs as an online VTAM application program.

NetView program. An IBM licensed program used to monitor and manage a network and to diagnose network problems.

network accessible unit (NAU). A logical unit (LU), physical unit (PU), control point (CP), or system services control point (SSCP). It is the origin or the destination of information transmitted by the path control network. Synonymous with *network addressable unit*.

network addressable unit (NAU). Synonym for *network accessible unit*.

network congestion. An undesirable overload condition caused by traffic in excess of what a network can handle.

Network Control Program (NCP). An IBM licensed program that provides communication controller support for single-domain, multiple-domain, and interconnected network capability.

network identifier. A 1- to 8-byte customer-selected name or an 8-byte IBM-registered name that uniquely identifies a specific subnetwork.

network performance analyzer (NPA). A function of NCP that collects performance data about devices. The data is recorded by NPM.

network-qualified name. In SNA, a name that uniquely identifies a specific resource (such as an LU or a CP) within a specific network. It consists of a network identifier and a resource name, each of which is a 1- to 8-byte symbol string. Synonymous with *fully qualified name*.

NIB. See *node initialization block*.

node. (1) In a network, a point at which one or more functional units connect channels or data circuits. (1) (2) Any device, attached to a network, that transmits and receives data. (3) An endpoint of a link or a junction common to two or more links in a network. Nodes can be processors, communication controllers, cluster controllers, or terminals. Nodes can vary in routing and other functional capabilities. (4) In VTAM, a point in a network defined by a symbolic name. See also *major node* and *minor node*.

node initialization block (NIB). In VTAM, a control block associated with a particular node or session that contains information used by the application program to identify the node or session and to indicate how communication requests on a session are to be handled by VTAM.

node type. A designation of a node according to the protocols it supports or the role it plays in a network. Node type was originally denoted numerically (as 1, 2.0, 2.1, 4, and 5) but is now characterized more specifically by protocol type (APPN network node, LEN node, subarea node, and interchange node, for example) because type 2.1 nodes and type 5 nodes support multiple protocol types and roles.

non-return-to-zero change-on-ones recording (NRZ-1). Non-return-to-reference recording in which the ones are represented by a change in the condition of magnetization, and zeros are represented by the

Glossary

absence of change. This method is called “mark recording” because only the one or mark signals are explicitly recorded. (I) (A) Synonymous with non-return-to-zero (mark) recording. (T) See Figure X-4.

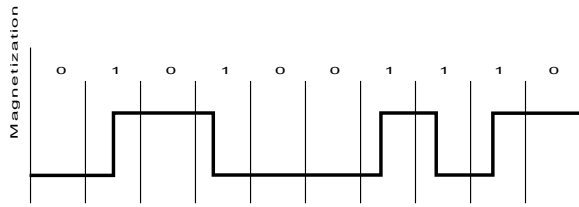

Figure X-4. Non-Return-to-Zero Change-on-Ones Recording

Non-SNA Interconnection (NSI). An IBM licensed program that provides format identification (FID) support for selected non-SNA facilities. Thus, it allows SNA and non-SNA facilities to share SDLC links. It also allows the remote concentration of selected non-SNA devices along with SNA devices.

noncanonical address. In LANs, a format for the transmission of medium access control (MAC) addresses for Token-Ring adapters. In noncanonical format, the most significant (leftmost) bit of each address byte is transmitted first. Contrast with *canonical address*.

NPA. See *network performance analyzer*.

NPDA. (1) Network Problem Determination Application. (2) A command that starts the NetView hardware monitor. NPDA also identifies various panels and functions as part of the hardware monitor.

NPM. See *NetView Performance Monitor*.

NPSI. See *X.25 NCP Packet Switching Interface*.

NRZ. Non-return-to-zero recording.

NRZ-1. See *non-return-to-zero change-on-ones recording*. (I) (A)

NRZI. Non-return-to-zero (inverted) recording. Synonym for *non-return-to-zero change-on-ones recording (NRZ-1)*.

NSI. See *Non-SNA Interconnection*.

NTRI. See *NCP/Token-Ring interconnection*.

NTuneMON. A program that runs with the NetView program and monitors NCPs that were activated by the VTAM on the host where NTuneMON is running.

NTuneNCP. A feature of NTuneMON that runs in a communication controller and, with VTAM, enables a network administrator to tune NCP interactively.

O

ODLC. See *outboard data link control*.

outboard data link control (ODLC). (1) Data link control (DLC) processing performed by a coprocessor. (2) In NCP, data link control (DLC) processing performed by the 3746 Model 900 connectivity subsystem (CSS).

outbound. In communications, data that is transmitted to the network.

P

PAB. See *process anchor block*.

padding. A technique by which a receiving component controls the rate of transmission of a sending component to prevent overrun or congestion. See also *flow control*, *session-level pacing*, and *virtual route (VR) pacing*.

pacing response. In SNA, an indicator that signifies the readiness of a receiving component to accept another pacing group. The indicator is carried in a response header (RH) for session-level pacing and in a transmission header (TH) for virtual route pacing.

pacing window. (1) The path information units (PIUs) that can be transmitted on a virtual route before a virtual-route pacing response is received, indicating that the virtual route receiver is ready to receive more PIUs on the route. (2) The requests that can be transmitted on the normal flow in one direction on a session before a session-level pacing response is received, indicating that the receiver is ready to accept the next group of requests.

packet. (1) In data communication, a sequence of binary digits, including data and control signals, that is transmitted and switched as a composite whole. The data, control signals and, possibly, error control information are arranged in a specific format. (I) (2) In X.25, a data transmission information unit. A group of data and control characters, transferred as a unit, determined by the process of transmission. Commonly used data field lengths in packets are 128 or 256 bytes. (3) The field structure and format defined in the CCITT X.25 Recommendation.

packet switching. The process of routing and transferring data by means of addressed packets so that a channel is occupied only during transmission of a packet. On completion of the transmission, the channel is made available for transfer of other packets. (I)

partitioned emulation programming (PEP) extension. A function of a network control program

that enables a communication controller to operate some telecommunication lines in network control mode while simultaneously operating others in emulation mode.

path. (1) In a network, any route between any two nodes. A path may include more than one branch. (T) (2) The series of transport network components (path control and data link control) that are traversed by the information exchanged between two network accessible units. See also *explicit route (ER)*, *route extension*, and *virtual route (VR)*.

path information unit (PIU). A message unit consisting of a transmission header (TH) alone, or a TH followed by a basic information unit (BIU) or a BIU segment.

PEP. See *partitioned emulation programming (PEP) extension*.

peripheral node. A node that uses local addresses for routing and therefore is not affected by changes in network addresses. A peripheral node requires boundary-function assistance from an adjacent subarea node. A peripheral node can be a type 1, 2.0, or 2.1 node connected to a subarea boundary node.

permanent virtual circuit (PVC). (1) In X.25 and frame-relay communications, a virtual circuit that has a logical channel permanently assigned to it at each data terminal equipment (DTE). Call-establishment protocols are not required. Contrast with *switched virtual circuit (SVC)*. (2) The logical connection between two frame-relay terminating equipment stations, either directly or through one or more frame-relay frame handlers. A PVC consists of one or more PVC segments.

physical line. In NCP, the physical connection between NCP and an adjacent device or local area network (LAN). A single physical line, such as Token-Ring or frame-relay, can support multiple logical lines. Contrast with *logical line*.

physical unit (PU). The component that manages and monitors the resources (such as attached links and adjacent link stations) associated with a node, as requested by an SSCP via an SSCP-PU session. An SSCP activates a session with the physical unit in order to indirectly manage, through the PU, resources of the node such as attached links. This term applies to type 2.0, type 4, and type 5 nodes only.

piggybacking. When data is sent between two NCPs or between an NCP and a link-attached station, the process of combining a PIU and an acknowledgment for a PIU that was previously sent.

PIU. See *path information unit*.

PLU. See *primary logical unit*.

point-to-point. Pertaining to data transmission between two locations without the use of any intermediate display station or computer.

polling. (1) On a multipoint connection or a point-to-point connection, the process whereby data stations are invited, one at a time, to transmit. (I) (2) Interrogation of devices for such purposes as to avoid contention, to determine operational status, or to determine readiness to send or receive data. (A)

port. An access point for data entry or exit.

primary logical unit (PLU). In SNA, the logical unit (LU) that sends the BIND to activate a session with its partner LU. Contrast with *secondary logical unit (SLU)*.

process anchor block (PAB). In VTAM, a process scheduling services dispatch point.

program temporary fix (PTF). A temporary solution or bypass of a problem diagnosed by IBM in a current unaltered release of the program.

PTF. See *program temporary fix*.

PU. See *physical unit*.

PU type. (1) Synonym for *node type*. (2) The type of physical unit in a node.

PVC. See *permanent virtual circuit*.

Q

queue. (1) A list constructed and maintained so that the next data element to be retrieved is the one stored first. (T) (2) A line or list of items waiting to be processed; for example, work to be performed or messages to be displayed.

quiesce. To end a process by allowing operations to complete normally.

R

receive not ready (RNR). In communications, a data link command or response that indicates a temporary condition of being unable to accept incoming frames.

request to send (RTS). In data communication, a signal raised by data terminal equipment (DTE), while the data terminal is ready, to request facilities from data circuit-terminating equipment (DCE) so that data can be sent. Contrast with *clear to send (CTS)*.

Restructured Extended Executor (REXX). A general-purpose, procedural language for end-user personal

Glossary

programming, designed for ease by both casual general users and computer professionals. It is also useful for application macros. REXX includes the capability of issuing commands to the underlying operating system from these macros and procedures. Features include powerful character-string manipulation, automatic data typing, manipulation of objects familiar to people, such as words, numbers, and names, and built-in interactive debugging.

REX. See *route extension*.

REXX. See *Restructured Extended Executor*.

RNR. See *receive not ready*.

route. An ordered sequence of nodes and transmission groups (TGs) that represent a path from an origin node to a destination node traversed by the traffic exchanged between them.

route extension (REX). In SNA, the path control network components, including a peripheral link, that make up the portion of a path between a subarea node and a network addressable unit (NAU) in an adjacent peripheral node. See also *explicit route (ER)*, *path*, and *virtual route (VR)*.

routing table. A collection of routes used to direct datagram forwarding or to establish a connection. The information is passed among routers to identify network topology and destination feasibility.

RR packet. A packet used by a data terminal equipment (DTE) or by a data circuit-terminating equipment (DCE) to indicate that it is ready to receive data packets within the window.

RTS. See *request to send*.

S

SAP. See *service access point*.

scanner. For the 3725 communication controller, a processor dedicated to controlling a small number of telecommunication lines. It provides the connection between the line interface coupler hardware and the central control unit.

SDLC. See *Synchronous Data Link Control*.

secondary logical unit (SLU). In SNA, the logical unit (LU) that contains the secondary half-session for a particular LU-LU session. An LU may contain secondary and primary half-sessions for different active LU-LU sessions. Contrast with *primary logical unit (PLU)*.

sequence number. (1) In communications, a number assigned to a particular frame or packet to control the

transmission flow and receipt of data. (2) A numerical value assigned by VTAM to each message exchanged between two nodes. The value (one for messages sent from the application program to the logical unit and another for messages sent from the logical unit to the application program) increases by one for each successive message transmitted unless it is reset by the application program with a set and test sequence numbers (STSN) indicator.

service access point (SAP). (1) In Open Systems Interconnection (OSI) architecture, the point at which the services of a layer are provided by an entity of that layer to an entity of the next higher layer. (T) (2) A logical point made available by an adapter where information can be received and transmitted. A single service access point can have many links terminating in it.

session. (1) In network architecture, for the purpose of data communication between functional units, all the activities which take place during the establishment, maintenance, and release of the connection. (T) (2) A logical connection between two network accessible units (NAUs) that can be activated, tailored to provide various protocols, and deactivated, as requested. Each session is uniquely identified in a transmission header (TH) accompanying any transmissions exchanged during the session.

session-level pacing. A flow control technique that permits a receiving half-session or session connector to control the data transfer rate (the rate at which it receives request units) on the normal flow. It is used to prevent overloading a receiver with unprocessed requests when the sender can generate requests faster than the receiver can process them. See also *virtual route (VR) pacing*.

shutdown. The process of ending operation of a system or a subsystem, following a defined procedure.

Simple Network Management Protocol (SNMP). In the Internet suite of protocols, a network management protocol that is used to monitor routers and attached networks. SNMP is an application layer protocol. Information on devices managed is defined and stored in the application's Management Information Base (MIB).

SNA. See *Systems Network Architecture*.

SNA network. The part of a user-application network that conforms to the formats and protocols of Systems Network Architecture. It enables reliable transfer of data among end users and provides protocols for controlling the resources of various network configurations. The SNA network consists of network accessible units (NAUs), boundary function, gateway function, and intermediate session routing function components; and the transport network.

SNA network interconnection (SNI). The connection, by gateways, of two or more independent SNA networks to allow communication between logical units in those networks. The individual SNA networks retain their independence.

snap. See *snapshot program*.

snapshot program. A trace program that produces output data only for selected instructions or for selected conditions. (I) (A)

SNI. See *SNA network interconnection*.

SNMP. See *Simple Network Management Protocol*.

soft error. (1) An error that occurs sporadically and that may not appear on successive attempts to read data. (2) An intermittent error on a network that requires retransmission.

Note: A soft error by itself does not affect overall reliability of a network, but reliability may be affected if the number of soft errors reaches the ring error limit.

source service access point (SSAP). In SNA and TCP/IP, a logical address that allows a system to send data to a remote device from the appropriate communications support. Contrast with *destination service access point (DSAP)*.

spare line. A line that is not in use and cannot be activated. It can be changed to a redefinable line using NTuneMON with NTuneNCP, then activated.

SS. See *start-stop (SS) transmission*.

SSAP. See *source service access point*.

SSCP. See *system services control point*.

SSP. See *System Support Programs*.

start-stop (SS) transmission. (1) Asynchronous transmission such that each group of signals representing a character is preceded by a start signal and is followed by a stop signal. (T) (A) (2) Asynchronous transmission in which a group of bits is (a) preceded by a start bit that prepares the receiving mechanism for the reception and registration of a character, and (b) followed by at least one stop bit that enables the receiving mechanism to come to an idle condition pending reception of the next character.

station. An input or output point of a system that uses telecommunication facilities; for example, one or more systems, computers, terminals, devices, and associated programs at a particular location that can send or receive data over a telecommunication line.

subarea. A portion of the SNA network consisting of a subarea node, attached peripheral nodes, and associated resources. Within a subarea node, all network accessible units (NAUs), links, and adjacent link stations (in attached peripheral or subarea nodes) that are addressable within the subarea share a common subarea address and have distinct element addresses.

subarea address. A value in the subarea field of the network address that identifies a particular subarea.

subarea link. In SNA, a link that connects two subarea nodes. See also *channel link*.

subnetwork. Any group of nodes that have a set of common characteristics, such as the same network ID.

suboperand. One of multiple elements in a list comprising an operand. See also *definition statement*.

subport. (1) An access point for data entry or exit over a logical connection. The relationship between the physical line and the port is analogous to the relationship between the logical connection and the subport. (2) In a frame-relay network, the representation of a logical connection on a frame-relay physical line and the point where the logical connection attaches to the frame-relay frame handler (FRFH). Each subport on a physical line has a unique data link connection identifier (DLCI) and can represent an FRTE, FRFH, or LMI connection. See *frame handler subport (FHSP)* and *terminal equipment subport*.

subsystem. A secondary or subordinate system, usually capable of operating independently of, or asynchronously with, a controlling system. (T)

supervisor call (SVC). A request that serves as the interface into operating system functions, such as allocating storage. The SVC protects the operating system from inappropriate user entry. All operating system requests must be handled by SVCs.

SVC. (1) See *supervisor call*. (2) See *switched virtual circuit*.

switched line. A telecommunication line in which the connection is established by dialing.

switched major node. In VTAM, a major node whose minor nodes are physical units and logical units attached by switched SDLC links.

switched virtual circuit (SVC). An X.25 circuit that is dynamically established when needed. The X.25 equivalent of a switched line. Contrast with *permanent virtual circuit (PVC)*.

Synchronous Data Link Control (SDLC). (1) A discipline conforming to subsets of the Advanced Data Communication Control Procedures (ADCCP) of the

Glossary

American National Standards Institute (ANSI) and High-level Data Link Control (HDLC) of the International Organization for Standardization, for managing synchronous, code-transparent, serial-by-bit information transfer over a link connection. Transmission exchanges may be duplex or half-duplex over switched or nonswitched links. The configuration of the link connection may be point-to-point, multipoint, or loop. (I) (2) Contrast with *binary synchronous communication (BSC)*.

system services control point (SSCP). A component within a subarea network for managing the configuration, coordinating network operator and problem determination requests, and providing directory services and other session services for end users of the network. Multiple SSCPs, cooperating as peers with one another, can divide the network into domains of control, with each SSCP having a hierarchical control relationship to the physical units and logical units within its own domain.

System Support Programs (SSP). An IBM licensed program, made up of a collection of utilities and small programs, that supports the operation of the NCP.

Systems Network Architecture (SNA). The description of the logical structure, formats, protocols, and operational sequences for transmitting information units through, and controlling the configuration and operation of, networks. The layered structure of SNA allows the ultimate origins and destinations of information, that is, the end users, to be independent of and unaffected by the specific SNA network services and facilities used for information exchange.

T

tailig. A feature on a multichannel modem that allows another modem link to be attached to one of the channels.

TCP/IP. See *Transmission Control Protocol/Internet Protocol*.

terminal equipment support. A support that serves as a termination point on a virtual circuit.

terminating equipment support (TESP). The endpoint of a frame-relay permanent virtual circuit (PVC); the point at which frame-relay terminating equipment has access to the PVC. A TESP provides higher-level functions with access to a frame-relay physical line. Each TESP in a single frame-relay port has a unique data link connection identifier (DLCI). Contrast with *frame handler support*.

TESP. See *terminating equipment support*.

TG. See *transmission group*.

threshold. In IBM bridge programs, a value set for the maximum number of frames that are not forwarded across a bridge due to errors, before a "threshold exceeded" occurrence is counted and indicated to network management programs.

TIC. See *Token-Ring interface coupler*.

timeout. (1) An event that occurs at the end of a pre-determined period of time that began at the occurrence of another specified event. (I) (2) A time interval allotted for certain operations to occur; for example, response to polling or addressing before system operation is interrupted and must be restarted.

token. (1) In a local area network, the symbol of authority passed successively from one data station to another to indicate the station temporarily in control of the transmission medium. Each data station has an opportunity to acquire and use the token to control the medium. A token is a particular message or bit pattern that signifies permission to transmit. (T) (2) In LANs, a sequence of bits passed from one device to another along the transmission medium. When the token has data appended to it, it becomes a frame.

Token Ring. (1) According to IEEE 802.5, network technology that controls media access by passing a token (special packet or frame) between media-attached stations. (2) A FDDI or IEEE 802.5 network with a ring topology that passes tokens from one attaching ring station (node) to another. (3) See also *local area network (LAN)*.

Token-Ring interface coupler (TIC). An adapter that can connect a 3720, 3725, or 3745 Communication Controller to an IBM Token-Ring Network.

Token-Ring network. (1) A ring network that allows unidirectional data transmission between data stations, by a token passing procedure, such that the transmitted data return to the transmitting station. (T) (2) A network that uses a ring topology, in which tokens are passed in a circuit from node to node. A node that is ready to send can capture the token and insert data for transmission.

trace. (1) A record of the execution of a computer program. It exhibits the sequences in which the instructions were executed. (A) (2) For data links, a record of the frames and bytes transmitted or received.

Transmission Control Protocol/Internet Protocol (TCP/IP). A set of communications protocols that support peer-to-peer connectivity functions for both local and wide area networks.

transmission group (TG). (1) A connection between adjacent nodes that is identified by a transmission group number. (2) In a subarea network, a single link

or a group of links between adjacent nodes. When a transmission group consists of a group of links, the links are viewed as a single logical link, and the transmission group is called a *multilink transmission group (MLTG)*. A *mixed-media multilink transmission group (MMMLTG)* is one that contains links of different medium types (for example, Token-Ring, switched SDLC, nonswitched SDLC, and frame-relay links). (3) In an APPN network, a single link between adjacent nodes.

transmission priority. A rank assigned to a message unit that determines its precedence for being selected by the path control component in each node along a route for forwarding to the next node in the route.

transmission subsystem (TSS). A line adapter that attaches to the IBM 3745 Communication Controller.

TSS. See *transmission subsystem*.

tuning. The process of adjusting an application or a system to operate in a more efficient manner in the work environment of a particular installation.

T1. In the United States, a 1.544-Mbps public access line. It is available in twenty-four 64-Kbps channels. The European version (E1) transmits 2.048 Mbps. The Japanese version (J1) transmits 1.544 Mbps.

U

UDP. See *User Datagram Protocol*.

upstream. In the direction of data flow from the end user to the host. Contrast with *downstream*.

User Datagram Protocol (UDP). In the Internet suite of protocols, a protocol that provides unreliable, connectionless datagram service. It enables an application program on one machine or process to send a datagram to an application program on another machine or process. UDP uses the Internet Protocol (IP) to deliver datagrams.

V

virtual machine (VM). (1) A virtual data processing system that appears to be at the exclusive disposal of a particular user, but whose functions are accomplished by sharing the resources of a real data processing system. (T) (2) In VM/ESA, the virtual processors, virtual storage, virtual devices, and virtual channel subsystem allocated to a single user. A virtual machine also includes any expanded storage dedicated to it.

Virtual Machine/Enterprise Systems Architecture (VM/ESA). An IBM licensed program that manages the resources of a single computer so that multiple com-

puting systems appear to exist. Each virtual machine is the functional equivalent of a real machine.

virtual processor. In VM/ESA, a representation of a processor that is dispatched by the Control Program (CP) on a real processor. It includes the contents of all registers and the state of the processor.

virtual route (VR). In SNA, either a) a logical connection between two subarea nodes that is physically realized as a particular explicit route or b) a logical connection that is contained wholly within a subarea node for intranode sessions. A virtual route between distinct subarea nodes imposes a transmission priority on the underlying explicit route, provides flow control through virtual route pacing, and provides data integrity through sequence numbering of path information units (PIUs). Contrast with *explicit route (ER)*. See also *path* and *route extension (REX)*.

virtual route (VR) pacing. In SNA, a flow control technique used by the virtual route control component of path control at each end of a virtual route to control the rate at which path information units (PIUs) flow over the virtual route. VR pacing can be adjusted according to traffic congestion in any of the nodes along the route. See also *session-level pacing*.

virtual route pacing response (VRPRS). A nonsequenced, supervisory path information unit (PIU) that flows at network priority. It may overtake VR-sequenced PIUs and consists of a transmission header with no basic information unit (BIU) data.

virtual storage. The storage space that may be regarded as addressable main storage by the user of a computer system in which virtual addresses are mapped into real addresses. The size of virtual storage is limited by the addressing scheme of the computer system and by the amount of auxiliary storage available, not by the actual number of main storage locations. (I) (A)

Virtual Storage Access Method (VSAM). An access method for direct or sequential processing of fixed and variable-length records on direct access devices. The records in a VSAM data set or file can be organized in logical sequence by a key field (key sequence), in the physical sequence in which they are written on the data set or file (entry-sequence), or by relative-record number.

Virtual Telecommunications Access Method (VTAM). An IBM licensed program that controls communication and the flow of data in an SNA network. It provides single-domain, multiple-domain, and interconnected network capability.

VM. See *virtual machine*.

Glossary

VM/ESA. See *Virtual Machine/Enterprise Systems Architecture*.

VR. See *virtual route*.

VSAM. See *Virtual Storage Access Method*.

VTAM. (1) See *Virtual Telecommunications Access Method*.

W

window. (1) A portion of a display surface in which display images pertaining to a particular application can be presented. Different applications can be displayed simultaneously in different windows. (A) (2) An area with visible boundaries that presents a view of an object or with which a user conducts a dialog with a computer system. (3) In data communication, the number of data packets a data terminal equipment (DTE) or data circuit-terminating equipment (DCE) can send across a logical channel before waiting for authorization to send another data packet. The window is the main mechanism of pacing, or flow control, of packets.

X

X.21. An International Telegraph and Telephone Consultative Committee (CCITT) recommendation for a general-purpose interface between data terminal equipment and data circuit-terminating equipment for synchronous operations on a public data network.

X.25. An International Telegraph and Telephone Consultative Committee (CCITT) recommendation for the interface between data terminal equipment and packet-switched data networks. See also *packet switching*.

X.25 NCP Packet Switching Interface (NPSI). An IBM licensed program that allows SNA users to communicate over packet switching data networks that have interfaces complying with CCITT Recommendation X.25. It allows SNA programs to communicate with SNA or non-SNA equipment over such networks.

X.25 ODLC. X.25 protocols processed by the IBM 3746 Model 900 connectivity subsystem (CSS) *outboard data link control* (ODLC) in conjunction with the IBM Network Control Program (NCP) licensed program.

XID. See *exchange identification*.

XRF. See *extended recovery facility*.

Bibliography

NCP, SSP, and EP Library

The following paragraphs briefly describe the library for NCP, SSP, and EP. Other publications related to NTuneMON, VTAM, NPSI, NetView, NTO, and NRF are listed without the accompanying descriptions.

NCP and EP Reference (LY43-0029)

This book describes various aspects of the internal processing of NCP and EP (PEP or EP Standalone). It provides information for customization and diagnosis.

NCP and EP Reference Summary and Data Areas (LY43-0030)

This two-volume book provides quick access to often-used diagnostic and debugging information about NCP and EP (PEP or EP Standalone).

NCP and SSP Customization Guide (LY43-0031)

This book helps users who are familiar with the internal logic of NCP and SSP to modify these products. It describes how to change NCP and SSP to support stations that IBM-supplied programs do not support.

NCP and SSP Customization Reference (LY43-0032)

This book supplements the *NCP and SSP Customization Guide*. It describes the resources and macroinstructions provided by IBM for customizing NCP and SSP.

NCP, SSP, and EP Diagnosis Guide (LY43-0033)

This book helps users isolate and define problems in NCP and EP (PEP or EP Standalone) using SSP. The primary purpose of the book is to help the user interact with the IBM Support Center to resolve a problem. In addition, it explains some of the diagnostic aids and service aids available with SSP.

NCP, SSP, and EP Trace Analysis Handbook (LY43-0037)

This book describes how to use the trace analysis program and how to read trace analysis program output.

NCP, SSP, and EP Generation and Loading Guide (SC31-6221)

This book provides detailed explanations of how to generate and load NCP and EP (PEP or EP Standalone)

using SSP. It contains information for generating and loading under MVS, VM, and VSE.

NCP, SSP, and EP Messages and Codes (SC31-6222)

This book is a reference book of abend codes issued by NCP and EP (PEP or EP Standalone), and messages issued by the System Support Programs associated with NCP. This information is also available through the online message facility, an IBM OS/2 application available on diskette.

NCP, SSP, and EP Resource Definition Guide (SC31-6223)

This book helps users understand how to define NCP and EP (PEP or EP Standalone), using SSP. It describes functions and resources and lists the definition statements and keywords that define those functions and resources.

NCP, SSP, and EP Resource Definition Reference (SC31-6224)

This book helps users code definition statements and keywords to define NCP and EP (PEP or EP Standalone), using SSP. It also provides a quick reference of definition statement coding order and keyword syntax.

NCP V7R8, SSP V4R8, and EP R14 Library Directory (SC30-4025)

This book helps users locate information on a variety of NCP, SSP, and EP tasks. It also provides a high-level understanding of NCP, SSP, and EP and summarizes the changes to these products and to the library for NCP V7R8, SSP V4R8, and EP R14.

NCP V7R8 Migration Guide (SC30-4024)

This book helps users migrate an NCP generation definition from an earlier release to NCP V7R8. It also describes how to add new functions for NCP V7R8.

NCP Version 7 and X.25 NPSI Version 3 Planning and Installation (SC30-3470)

This book helps users plan and install support for X.25 lines in the 3745 or 3746 Model 900.

NCP Version 7 and X.25 NPSI Version 3 Diagnosis, Customization, and Tuning (LY30-5610)

This book helps users diagnose, customize, and tune X.25 lines in the 3745 or 3746 Model 900.

Other Networking Products' Libraries

The following publications provide cross-product information for NTuneMON, SNA Services (VTAM), NPSI, NetView, and NPM. For detailed information about these products, refer to the library for each.

Networking Library

Planning for NetView, NCP, and VTAM (SC31-8063)

Planning for Integrated Networks (SC31-8062)

ACF/NCP, ACF/SSP, EP, NTuneMON, and NPSI Softcopy Collection Kit (CD-ROM, LK2T-0414)

NTuneMON Library

NTuneMON User's Guide (SC31-6266)

NTuneNCP Feature Reference (LY43-0039)

Related Publication: *NCP Tuning with NTune*, GG24-2520

SNA Services Library (formerly VTAM Library)

OS/390 SecureWay Communications Server: SNA Planning and Migration Guide (SC31-8622)

OS/390 SecureWay Communications Server: SNA Network Implementation (SC31-8563)

OS/390 SecureWay Communications Server: SNA Resource Definition Reference (SC31-8565)

OS/390 SecureWay Communications Server: SNA Operation (SC31-8567)

OS/390 SecureWay Communications Server: Quick Reference (SX75-0121)

OS/390 SecureWay Communications Server: SNA Diagnosis Vol 1 (LY43-0079)

OS/390 SecureWay Communications Server: SNA Diagnosis Vol 2 (LY43-0080)

OS/390 SecureWay Communications Server: SNA Messages (SC31-8569)

OS/390 SecureWay Communications Server: IP and SNA Codes (SC31-8571)

OS/390 SecureWay Communications Server: Data Areas Vol 1 (LY43-0111)

OS/390 SecureWay Communications Server: Data Areas Vol 2 (LY43-0112)

OS/390 SecureWay Communications Server: SNA Customization (LY43-0110)

OS/390 SecureWay Communications Server: Anynet Sockets over SNA (SC31-8577)

NPSI Library

X.25 NPSI Version 3 General Information (GC30-3469)

NCP Version 7 and X.25 NPSI Version 3 Planning and Installation (SC30-3470)

X.25 NPSI Version 3 Host Programming (SC30-3502)

NCP Version 7 and X.25 NPSI Version 3 Diagnosis, Customization, and Tuning (LY30-5610)

X.25 NPSI Version 3 Release 9 Data Areas (LY30-5627)

NetView Library

TME 10 NetView for OS/390 NGMF User's Guide (SC31-8234)

TME 10 NetView for OS/390 User's Guide (SC31-8241)

TME 10 NetView for OS/390 Administration and Security Reference (SC31-8222)

TME 10 NetView for OS/390 Application Programmer's Guide (SC31-8223)

TME 10 NetView for OS/390 Automation Guide (SC31-8225)

TME 10 NetView for OS/390 Bridge Implementation (SC31-8238)

TME 10 NetView for OS/390 Command Reference (SC31-8227)

TME 10 NetView for OS/390 Customization Guide (SC31-8228)

TME 10 NetView for OS/390 Customization: Using Assembler (SC31-8229)

TME 10 NetView for OS/390 Customization: Using PL/I and C (SC31-8230)

TME 10 NetView for OS/390 Customization: Using REXX and the NetView Command List Language (SC31-8231)

TME 10 NetView for OS/390 Planning Guide (GC31-8226)

TME 10 NetView for OS/390 Installation and Administration Guide (SC31-8236)

TME 10 NetView for OS/390 Messages (SC31-8237)

TME 10 NetView for OS/390 Diagnosis Guide (LY43-0108)

TME 10 NetView for OS/390 Resource Object Data Manager and GMFHS Programmer's Guide (SC31-8233)

TME 10 NetView for OS/390 Tuning Guide (SC31-8240)

TME 10 NetView for OS/390 User's Guide (SC31-8241)

TME 10 NetView for OS/390 NGMF User's Guide (SC31-8234)

TME 10 NetView for OS/390 SNA Topology Manager and APPN Accounting Manager Implementation Guide (SC31-8239)

TME 10 NetView for OS/390 Data Model Reference (SC31-8232)

TME 10 NetView for OS/390 APPN Topology and Accounting Agent Guide (SC31-8224)

NPM Library

NPM Concepts and Planning (GH19-6961-03)

NPM Installation and Customization (SH19-6964-03)

NPM Desk/2 User's Guide (SH19-6963-02)

NPM User's Guide (SH19-6962-03)

NPM Messages and Codes (SH19-6966-03)

NPM Graphic Subsystem (SH19-6967-00)

NPM Reference (SH19-6965-03)

NPM Diagnosis (LY19-6381-03)

NTO Library

Network Terminal Option: Planning, Migration, and Resource Definition Guide (SC30-3347)

Network Terminal Option: Diagnosis (LY30-3194)

NRF Library

NRF Planning (SC27-0593)

NRF Migration, Resource Definition and Customization (SC31-6203)

NRF Resource Definition and Customization (SC30-3407)

NRF Diagnosis (LY30-5597)

Related Publications

The following publications, though not directly related to this book, may be helpful in understanding your network.

Internet Standard Subnetting Procedure (TCP/IP RFC 950)

Network Design and Analysis General Information (GC30-3495)

Remote Loading/Activation Guide (SA33-0161)

3745 and 3746 Service Processor Installation and Maintenance (SY33-2115)

TPF Concepts and Structures Manual (GH20-7488)

IBM 3745 Communication Controller Publications

The following list shows selected publications for the IBM 3745 Communication Controller.

IBM 3745 Communication Controller Introduction (GA33-0138 for the 3745-130, 3745-150, and 3745-170)

IBM 3745 Communication Controller Introduction (GA33-0092 for the 3745-210, 3745-310, 3745-410, and 3745-610)

IBM 3745 Communication Controller All Models and 3746 Model 900: Connection and Integration Guide (SA33-0129)

3745 Communications Controller Models 130, 150, 160, and 170: Connection and Integration Guide (SA33-0141)

IBM 3745 Communication Controller (All Models): Principles of Operation (SA33-0102)

IBM 3745 Advanced Operations Guide (SA33-0097)

Bibliography

3745 Communication Controller Model A, 3746 Nways Multiprotocol Controller Models 900 and 950: Planning Guide (GA33-0457)

IBM 3745 Problem Determination Guide (SA33-0096)

IBM 3746 Model 900 and Model 950 Publications

IBM 3745 Communication Controller Model A, IBM 3746 Expansion Unit Model 900, IBM 3746 Nways Multinetwork Controller Model 950 Overview (GA33-0180)

IBM 3746 Nways Multinetwork Controller Model 950 User's Guide (SA33-0356)

MVS/ESA Publications

MVS/ESA Device Validation Support (GC28-1617)

MVS/ESA Hardware Configuration Definition: User's Guide (GC33-6457)

SNA Publications

The following publications contain information on SNA.

Systems Network Architecture Technical Overview (GC30-3073)

Systems Network Architecture Management Services Reference (SC30-3346)

Systems Network Architecture Formats (GA27-3136)

TCAM Publications

TCAM Version 2 Base Installation Guide (SC30-3132)

TCAM Version 2 Networking Installation Guide (SC30-3153)

TCP/IP Publications

The following publications contain information on Transmission Control Protocol/Internet Protocol (TCP/IP).

General: The following list shows selected publications with general information on TCP/IP.

Internetworking with TCP/IP Volume I: Principles, Protocols, and Architecture, Douglas E. Comer, Prentice Hall, Englewood Cliffs, New Jersey, 1991 (SC31-6144)

Internetworking with TCP/IP Volume II: Implementation and Internals, Douglas E. Comer, Prentice Hall, Englewood Cliffs, New Jersey, 1991 (SC31-6145)

TCP/IP Introduction (GC31-6080)

IBM TCP/IP Tutorial and Technical Overview (GG24-3376)

OS/390 Publications: The following list shows selected publications on IP Services for the OS/390 SecureWay Communications Server.

OS/390 SecureWay Communications Server: IP Planning and Migration Guide (SC31-8512)

OS/390 SecureWay Communications Server: IP User's Guide (GC31-8514)

MVS Publications: The following list shows selected publications on TCP/IP for MVS.

IBM TCP/IP for MVS: Planning and Migration Guide (SC31-7189)

IBM TCP/IP for MVS: User's Guide (SC31-7136)

VM Publications: The following list shows selected publications on TCP/IP for VM.

IBM TCP/IP Version 2 Release 4 for VM: Planning and Customization (SC31-6082)

IBM TCP/IP Version 2 Release 4 for VM: User's Guide (SC31-6081)

IBM OS/2 Publications: The following list shows selected publications on TCP/IP for IBM OS/2.

IBM TCP/IP Version 2.0 for OS/2: Installation and Administration (SC31-6075)

IBM TCP/IP Version 2.0 for OS/2: User's Guide (SC31-6076)

DOS Publications: The following list shows selected publications on TCP/IP for DOS.

IBM TCP/IP Version 2.1.1 for DOS: Installation and Administration (SC31-7047)

IBM TCP/IP Version 2.1.1 for DOS: User's Guide (SC31-7045)

Index

Special Characters

- (not available), what it means on a panel 3-9
- #PIUs/BLOCK tuning field
 - ATUFT1 Frame Relay Terminating Equipment Details Page 1 panel 4-138, 6-73
 - ATUSD SDLC Station Details panel 4-242, 6-114
 - ATUTL Token-Ring SNA Station panel 4-303, 6-160

Numerics

- 3745 publications X-23
- 3746 Model 900 Adapters panel 4-237
- 3746 Model 900 connectivity subsystem (CSS)
 - adapters 4-237
 - CLP (Communication Line Processor) 4-238
 - ESCON links
 - logical lines 2-22, 4-43
 - stations 2-22, 4-39
 - serial number 4-262
 - terminology xx
 - Token Ring
 - ATUTP1 Token-Ring TIC Details Page 1 panel 4-310, 6-170
 - ATUTP2 Token-Ring TIC Details Page 2 panel 4-319, 6-178
- 3746 Model 900 ESCON Logical Lines panel 4-43
- 3746 Model 900 ESCON Station Details panel
- 3746 Nways Multiprotocol Controller 6-17
- 3746 publications X-24
- 3746-900 Logical Lines panel 4-43
- 3746-900 Station Details panel 4-39
 - tuning 6-12
- 37CS
 - See 3746 Model 900 connectivity subsystem (CSS)

A

- abbreviations, list of X-1
- ACTIVTO tuning field
 - ATUSP2 SDLC Peripheral Line Parameters Page 2 panel 4-256, 6-135
 - cross-reference table 5-6
- adapter scanners
 - channel 2-24, 4-230
 - line 2-24, 4-233
- adapters
 - Ethernet-type subsystem (ESS)
 - list 4-81
 - statistics 4-84
 - Token-Ring
 - list 4-278
 - status 4-313

- adaptive pacing window 4-154
 - tuning 6-87
- adding SDLC lines
 - defining redefinable line 7-6
 - defining spare line 7-5
 - disabling SDLC redefinable line 7-6
 - enabling spare line 7-5
 - keywords for peripheral lines 7-6
 - line types 7-3
 - overview 7-3
 - restrictions 7-8
 - VTAM support 7-9
- ADDR keyword
 - ATUCL 3746-900 Station Details panel 4-40
 - ATUCS 3746-900 Logical Lines panel 4-44
 - ATUDK ISDN Physical Line Details panel 4-52
 - ATUDN ISDN B-Channel Line Details panel 4-67
 - ATUDT ISDN Station Details panel 4-74
 - ATUFA Frame Relay Support List panel 4-89
 - ATUFS1 Frame Relay Switching Equipment Page 1 panel 4-128
 - ATUFS2 Frame Relay Switching Equipment Page 2 panel 4-132
 - ATUFT1 Frame Relay Terminating Equipment Details Page 1 panel 4-136
 - ATUFT2 Frame Relay Terminating Equipment Details Page 2 panel 4-144
 - ATUSL SDLC Stations List panel 4-247
 - ATUTL Token-Ring SNA Station panel 4-305, 6-164
- ADDR monitoring field
 - See *also* ADDRESS monitoring field
 - See *also* Line Address monitoring field
 - ATUCS 3746-900 Logical Lines panel 4-44
 - ATUDL ISDN Physical Line Table panel 4-60
 - ATUDM ISDN B-Channel Line Table panel 4-63
 - ATUFC Physical Line List panel 4-95
 - ATUSL SDLC Stations List panel 4-247
 - ATUXL X.25 MCH Physical Line List panel 4-351
- ADDR option 2-15
- address
 - ADDR option 2-15
 - beaconing (Token Ring) 4-313
 - hexadecimal 2-19, 4-68
 - MAC 4-279, 4-282
 - TYPE=MAC 2-22
 - TIC (port)
 - ATUFT1 Frame Relay Terminating Equipment Details Page 1 panel 4-139
 - ATUTC Token-Ring Adapter List panel 4-279
 - ATUTP1 Token-Ring TIC Details Page 1 panel 4-311
 - ATUTP2 Token-Ring TIC Details Page 2 panel 4-320

Index

- address (*continued*)
 - TIC (port) (*continued*)
 - option table 2-25
 - Token Ring, tuning 6-170, 6-178
 - Token-Ring IDBLK 2-15, 4-74, 4-282
 - Token-Ring line 2-15, 4-278
- ADDRESS keyword 4-122
- ADDRESS monitoring field
 - See also ADDR monitoring field
 - See also Line Address monitoring field
- ATUDM ISDN B-Channel Line Table panel 4-62
- ATUNI NTuneNCP Information panel 4-200
- Address Resolution Protocol (ARP) analysis 2-22
 - See also ARP Address Format tuning field, ARP table entry panel
- ADPLIMIT keyword 4-154
 - tuning 6-87
- alarms
 - See alert thresholds
- ALERT CNT tuning field
 - ATUBP NCP Buffer Pool panel 4-8, 6-6
- alert thresholds
 - See also thresholds
 - ATUBP NCP Buffer Pool panel 4-7
 - ATUCB Control Block Pools/Tables panel 4-24
 - ATUGP Network CB Pools/Tables panel 4-150
 - ATUNT NCP Network Names Table panel 4-210
 - GWNAUs 4-160, 4-193
 - GWNAUs, non-dynamic 4-162
 - Internet router 4-178
 - SNI networks and HSCBs 4-202
 - Token-Ring 4-279
 - transmission groups 4-265
 - virtual routes 4-264
- ALERT THRSH tuning field
 - ATUBP NCP Buffer Pool panel 4-7, 6-6
 - ATUCB Control Block Pools/Tables panel 4-24
 - ATUGP Network CB Pools/Tables panel 4-150
 - ATUIS IP Router Statistics Page 1 panel 4-178
- ALERT% tuning field
 - ATUBP NCP Buffer Pool panel 4-8, 6-6
- alerts, control block pool
 - See control block pool alerts
- alerts, generic
 - ATUBP NCP Buffer Pool panel 4-7
 - ATUCB Control Block Pools/Tables panel 4-24
 - ATUGP Network CB Pools/Tables panel 4-150
 - ATUNT NCP Network Names Table panel 4-210
 - definition of term X-10
 - GENALERT option 2-17
 - GWNAUs 4-160, 4-193
 - GWNAUs, non-dynamic 4-162
 - messages 8-1
 - SNI networks and HSCBs 4-202
 - SUMMARY panel 4-263, 4-265
 - Token-Ring 4-279
- alerts, generic (*continued*)
 - transmission groups 4-265, 4-295
 - virtual routes 4-263, 4-335
- ANSTONE tuning field
 - ATUFP2 Frame Relay Details Page 2 panel 4-119, 6-49
 - ATUSP1 SDLC Peripheral Line Parameters Page 1 panel 4-251, 6-124
 - cross-reference table 5-6
- ARP Address Format tuning field 2-22
 - ATUID IP Interface Information Detail panel 4-166, 6-91
- ARP Table Entry panel 4-155
- ARPTAB keyword
 - See also ARP Address Format tuning field
- ATUID IP Interface Information Detail panel 6-91
 - cross-reference table 5-6
- Attention notices
 - 2845 and 2848 control units 6-141
 - global variables, saving 2-18
 - NTuneNCP access via NTuneMON 5-6
 - programming interface, not a xvi
 - reloading while tuning 5-6
 - scanner error, false 6-140
 - timer restrictions 6-97, 6-100
- ATUBP NCP Buffer Pool panel 4-4, 6-4
- ATUBS Buffer Slowdown Information Page 1 panel 4-10
- ATUBX Buffer Slowdown Information Page 2 panel 4-14
- ATUCB Control Block Pools/Tables panel 4-17
- ATUCD CDS NCP Selection panel 4-27
- ATUCH Channel Adapter Details panel 4-32
 - tuning 6-10
- ATUCI Channel IP Statistics panel 4-36
- ATUCL 3746-900 Station Details panel 4-39
 - tuning 6-12
- ATUCS 3746-900 Logical Lines panel 4-43
- ATUCX Control Block Pools Extension panel 4-47
- ATUDK ISDN Physical Line Details panel 4-49
 - tuning 6-15
- ATUDK2 ISDN Physical Line Details Page 2 panel monitoring 4-55
 - tuning 6-19
- ATUDL ISDN Physical Line Table panel 4-59
- ATUDM ISDN B-Channel Line Table panel 4-62
- ATUDN ISDN B-Channel Line Details panel 4-65
- ATUDP Hexadecimal Storage Display panel 4-68
- ATUDS ISDN Stations Table List panel 4-71
- ATUDT ISDN Station Details panel 4-73
 - tuning 6-24
- ATUED PEP Line Details panel 4-78
- ATUEP Ethernet Adapter List panel 4-81
- ATUET Ethernet Adapter Statistics panel 4-84
- ATUFA Frame Relay Support List panel 4-88

- ATUFB Frame Relay DLCI CIR Parameters
 - panel 4-92
 - tuning 6-26
- ATUFC Physical Line List panel 4-94
- ATUFD Frame Relay DLCI to Balance Table
 - panel 4-99
 - tuning 6-29
- ATUFI Frame-Relay IP Link Statistics panel 4-102
 - tuning 6-32
- ATUFL Frame Relay Multi Station List panel 4-105
- ATUFP Frame Relay Physical Line Details Page 1
 - panel 4-108, 6-34
- ATUFP2 Frame Relay Details Page 2 panel 4-117
 - tuning 6-48
- ATUFP3 Frame Relay Details Page 3 panel
 - monitoring 4-122
 - tuning 6-53
- ATUFS1 Frame Relay Switching Equipment Page 1
 - panel 4-127, 6-61
- ATUFS2 Frame Relay Switching Equipment Page 2
 - panel 4-131
- ATUFT1 Frame Relay Terminating Equipment Details
 - Page 1 panel 4-135, 6-64
- ATUFT2 Frame Relay Terminating Equipment Details
 - Page 2 panel 4-143, 6-78
- ATUGP Network CB Pools/Tables panel 4-149
 - tuning 6-81
- ATUHP HPR & Other Global Flow Control Params
 - panel 4-153, 6-84
- ATUIA ARP Table Entry panel 4-155
- ATUIB GWNAUs in Use Counts panel 4-158
- ATUIC Non-Dynamic GWNAUs in Use Counts
 - panel 4-161
- ATUID IP Interface Information Detail panel 4-164,
 - 6-90
- ATUIL IP Interface Information panel 4-169
- ATUIR IP Route Table Entries panel 4-172
- ATUIS IP Router Statistics Page 1 panel 4-175
- ATUIX IP Router Statistics Page 2 panel 4-180
- ATUML Multi-Link Transmission Group panel 4-184,
 - 6-93
- ATUMT Modify Timer Value panel 4-189, 6-97
- ATUNA GWNAU Names and HSCBs panel 4-192
- ATUNELST (authorized users' list) 2-9, 2-11
- ATUNEMON command options
 - ADDR 2-15
 - DEBUG 2-16
 - FAST 2-17
 - GENALERT 2-17
 - GLOBAL 2-18
 - HEX 2-19
 - NETWORK 2-19
 - OUTPUT 2-15
 - RESET 2-19
 - SCOPE 2-20
 - SUBAREA 2-21
- ATUNEMON command options (*continued*)
 - TGN 2-21
 - TYPE 2-21
- ATUNG HSCBs and GWNAUs panel 4-195
- ATUNI NTuneNCP Information panel 4-199
- ATUNN HSCBs (Networks and HSCB Counts)
 - panel 4-201
- ATUNP NCP Selection panel 4-204
- ATUNT NCP Network Names Table panel 4-209
- ATUNW NCP Wide Selection panel 4-212
- ATUPL SDLC Physical Line Details panel 4-217,
 - 6-102
- ATUPS Bisync/SS Line Details panel 4-223
- ATUPT Bisync/Start Stop Device List panel 4-227
- ATUSC1 Channel Adapters panel 4-230
- ATUSC2 Line Adapters Page 1 panel 4-233
- ATUSC3 Line Adapters Page 2 panel 4-233
- ATUSC4 3746 Model 900 Adapters panel 4-237
- ATUSD SDLC Station Details panel 4-241, 6-113
- ATUSL SDLC Stations List panel 4-246
- ATUSP1 SDLC Peripheral Line Parameters Page 1
 - panel 4-249, 6-122
- ATUSP2 SDLC Peripheral Line Parameters Page 2
 - panel 4-255, 6-134
- ATUSS Summary Status panel 4-260
- ATUST NCP Function Activation panel 4-269, 6-147
- ATUTA Token-Ring SNA Station List panel 4-273
- ATUTC Token-Ring Adapter List panel 4-278
- ATUTD NTRI Frame Handlers Logical Line Details
 - panel 4-285, 6-152
- ATUTF NTRI Frame Handler Logical Lines
 - panel 4-291
- ATUTG Transmission Group panel 4-294
- ATUTI Token-Ring IP Statistics panel 4-298
- ATUTL Token-Ring SNA Station panel 4-301, 6-156
- ATUTP1 Token-Ring TIC Details Page 1 panel 4-310,
 - 6-170
- ATUTP2 Token-Ring TIC Details Page 2 panel 4-319,
 - 6-178
- ATUUH Cycle/Buffer Utilization History panel 4-325
- ATUUT NCP Utilization panel 4-328
- ATUVA Virtual Route Control Block Details
 - panel 4-331, 6-182
- ATUVR Virtual Route panel 4-334
- ATUVT VR Alert Timer panel 4-338
 - tuning 6-185
- ATUXD X.25 Virtual Circuit Details panel 4-341
- ATUXF NPSI Virtual Circuit Statistics panel 4-346
- ATUXH X.25 MCH Physical Line Statistics
 - panel 4-348
- ATUXL X.25 MCH Physical Line List panel 4-350
- ATUXP X.25 MCH Physical Line Details Page 1
 - panel 4-353
 - tuning 6-189
- ATUXS X.25 MCH Physical Line Details Page 2
 - panel 4-362

Index

ATUXV X.25 Virtual Circuit List panel 4-366
ATUXX X.25 VCCPT Information panel 4-369
authorized users' list (ATUNELST) 2-11
AUTO monitoring field 4-119

B

Backup Host IP Owner monitoring field 4-167
Bal Factor tuning field 4-100, 6-29
BALANCE keyword 6-174
 ATUFD Frame Relay DLCI to Balance Table
 panel 4-100, 6-29
 ATUTP1 Token-Ring TIC Details Page 1
 panel 4-315
BAN identifier 4-71, 4-114
BDGLF (bridges' largest frame) monitoring field 4-302
beaconing 4-313
BECNS RECEIVED monitoring field 4-145
BECNS SENT monitoring field 4-145
bibliography X-21
bidirectional pacing mechanism 4-45
Bisync/SS Line Details panel 4-223
Bisync/Start Stop Device List panel 4-227
BLOCK GEN tuning field
 See also BLOCK(bytes) keyword
 ATUFT1 Frame Relay Terminating Equipment
 Details Page 1 panel 4-140, 6-75
 ATUSD SDLC Station Details panel 4-244, 6-119
 ATUTL Token-Ring SNA Station panel 4-307,
 6-167
BLOCK(bytes) keyword
 See also BLOCK GEN tuning field
 ATUFT1 Frame Relay Terminating Equipment
 Details Page 1 panel 6-75
 ATUSD SDLC Station Details panel 6-119
 ATUTL Token-Ring SNA Station panel 6-167
 cross-reference table 5-6
BLOCK(pius) keyword
 See also #PIUs/BLOCK tuning field
 ATUFT1 Frame Relay Terminating Equipment
 Details Page 1 panel 6-73
 ATUSD SDLC Station Details panel 6-114
 ATUTL Token-Ring SNA Station panel 6-160
 cross-reference table 5-6
blue highlighting
 See turquoise highlighting
boundary pool (BPOOL)
 ATUBP NCP Buffer Pool panel 4-6, 4-7
congestion, virtual routes 4-335
 full 4-5
 summary status 4-262
boundary session control block (BSB) 4-20
BPOOL
 See boundary pool (BPOOL)
bridged route 6-168

bridges' largest frame (BDGLF) monitoring field 4-302
bridges, Token-Ring 4-301, 6-156
BSB (boundary session control block) 4-20
BSC/SS/PEP panel group 1-7
Buffer Slowdown Information Page 1 panel 4-10
Buffer Slowdown Information Page 2 panel 4-14
buffer usage, monitoring 4-325
buffers
 BPOOL (boundary pool) 4-262
 CCU utilization histogram 4-328
 DYNPOOL (dynamic control block pool) 1-17, 4-7,
 6-5
 IPPOOL (Internet Protocol pool) 1-17, 4-6, 6-4
 pools
 ATUCX Control Block Pools Extension
 panel 4-47
 ATUGP Network CB Pools/Tables panel 4-149
 control block 4-17
 NCP buffer 4-4, 6-4
 overview 1-17, 2-22
Buffers monitoring field
 ATUBP NCP Buffer Pool panel 4-6
 ATUSS Summary Status panel 4-262
 ATUXL X.25 MCH Physical Line List panel 4-351
 ATUXP X.25 MCH Physical Line Details Page 1
 panel 4-354, 4-358
burst size 6-26

C

CBB minor control block 4-19
CCLID tuning field
 ATUSP1 SDLC Peripheral Line Parameters Page 1
 panel 4-251, 6-125
 cross-reference table 5-6
CCU (central control unit) monitoring field
 ATUBP NCP Buffer Pool panel 4-4
 ATUBS Buffer Slowdown Information Page 1
 panel 4-10
 ATUCB Control Block Pools/Tables panel 4-19
 ATUPL SDLC Physical Line Details panel 4-218
 ATUSS Summary Status panel 4-260
 ATUUT NCP Utilization panel 4-329
 ATUXL X.25 MCH Physical Line List panel 4-351
CCU and buffer utilization histogram 4-328
CCU-MODE monitoring field 4-28
CD-ROM documentation xxiv
CDS information 2-22, 4-27
CDS NCP selection panel 4-27
CDS_DATE monitoring field 4-28
central control unit (CCU) monitoring field
 ATUBP NCP Buffer Pool panel 4-4
 ATUBS Buffer Slowdown Information Page 1
 panel 4-10
 ATUCB Control Block Pools/Tables panel 4-19
 ATUPL SDLC Physical Line Details panel 4-218

- central control unit (CCU) monitoring field (*continued*)
 - ATUSS Summary Status panel 4-260
 - ATUUT NCP Utilization panel 4-329
 - ATUXL X.25 MCH Physical Line List panel 4-351
- changes to NTune xxi
- changing NCP names 3-6
- Channel Adapter Details panel 4-32
 - tuning 6-10
- channel adapter scanners 2-24, 4-230
- Channel Adapters panel 4-230
- channel adapters panel group 1-8
- Channel IP Statistics panel 4-36
- checksum support 4-76, 6-25, 6-76, 6-120, 6-167
- CIR (committed information rate) 4-53, 4-124
- CIR keyword and field 4-53, 4-124, 6-15, 6-57
- CLISTs 2-1, 2-8, 2-9
- CLOCKNG keyword and field
 - ATUDK ISDN Physical Line Details panel 4-50
 - ATUED PEP Line Details panel 4-79
 - ATUFP Frame Relay Physical Line Details Page 1 panel 4-110
 - ATUPL SDLC Physical Line Details panel 4-219, 6-107
 - ATUPS Bisync/SS Line Details panel 4-225
 - ATUSP1 SDLC Peripheral Line Parameters Page 1 panel 4-251, 6-125
 - ATUXP X.25 MCH Physical Line Details Page 1 panel 4-355, 4-360, 6-193
- CLP (communication line processor) 4-238
- color, use of 2-4, 3-10
- commands
 - fast-path 3-4
 - options 2-13
 - See also* NTuneMON command options
- committed information rate (CIR) 4-53, 4-124
 - adaptive algorithm 4-53, 6-16
 - Model 900 processing, reference to book on 6-17
- communication controller serial number 4-28, 4-213, 4-261
- communication line processor (CLP) 4-238
- communications rate priority 4-118, 6-48
- compiling NTuneMON (MVS) 2-8
- COMRATE keyword 6-21, 6-55
- COMRATE tuning field
 - ATUDT ISDN Station Details panel 4-76
 - ATUFS1 Frame Relay Switching Equipment Page 1 panel 4-128, 6-61
 - ATUFT1 Frame Relay Terminating Equipment Details Page 1 panel 4-136, 4-144, 6-65
 - ATUTD NTRI Frame Handlers Logical Line Details panel 4-286, 6-152
 - ATUTF NTRI Frame Handler Logical Lines panel 4-292
 - ATUTP2 Token-Ring TIC Details Page 2 panel 4-321, 6-178
- congestion control 6-25, 6-55
- CONGESTION field
 - ATUFT1 Frame Relay Terminating Equipment Details Page 1 panel 4-137, 6-66
 - ATUSD SDLC Station Details panel 4-242, 6-114
 - ATUTL Token-Ring SNA Station panel 4-303, 6-159
- Conn Bal Fact tuning field 4-315, 6-174
- connectivity subsystem (CSS)
 - adapters 4-237
 - CLP (Communication Line Processor) 4-238
 - ESCON links
 - logical lines 2-22, 4-43
 - stations 2-22, 4-39
 - terminology xx
 - Token Ring
 - ATUTP1 Token-Ring TIC Details Page 1 panel 4-310, 6-170
 - ATUTP2 Token-Ring TIC Details Page 2 panel 4-319, 6-178
- control block documentation, references to
 - NSA 4-11
 - NSP 4-11
 - VRB 4-12
- control block in-use counts 4-19, 4-150
- control block pool alerts 8-1
- Control Block Pools Extension panel 4-47
- control block pools, monitoring
 - BSB (boundary session control block) 4-20
 - CBB minor control block 4-19
 - CX2 minor control block 4-19
 - CXB minor control block 4-19
 - CXI minor control block 4-19
 - FCT (file control parameter table) 4-21
 - FR LLB (frame-relay logical link block) 4-22
 - HRE (host route entry pool) 4-22
 - HSCB (half-session control block) 4-19
 - LAE (local address entry) 4-23
 - LNB (logical unit address control block) 4-20
 - LND (dependent logical unit boundary session control block) 4-20
 - LTX (logical unit terminal node extension) 4-20
 - LUB (logical unit control block) 4-19
 - LUX (XRF logical unit block extensions) 4-21
 - LXE (LU control block extensions) 4-24
 - NNT (network names table) 4-21
 - NQE (NPA counter queue elements) 4-23
 - NQX (NPA counter queue element extensions) 4-23
 - NRE (network route entry pool) 4-22
 - NSB (NPM frame-relay physical station data block) 4-23
 - NSC (NPA session counters) 4-21
 - NSX (NPA session counter extension) 4-21
 - NUMHSAS (number of subareas) 4-20
 - NVT (network vector table) 4-23

Index

- control block pools, monitoring (*continued*)
 - ODLC LAN (ODLC LAN logical resources) 4-21
 - PUDR (physical unit dynamic reconfiguration pool) 4-19
 - RVT (resource vector table) 4-19, 4-23
 - SCE minor control block 4-19
 - SNP (SSCP-NCP session control block) 4-24
 - SRE (subnetwork route entry pool) 4-23
 - SSB minor control block 4-19
 - TGB (transmission group control block) 4-150
 - TR LLB (Token-Ring logical link block) 4-21
 - TRT (transit routing table) 4-24, 4-150
 - VVT (virtual route vector table) 4-21
 - Control Block Pools/Tables panel 4-17
 - copying data to NetView log 3-11
 - CPNAME, monitoring (Token Ring) 4-282
 - CPNAME, specifying (Token Ring) 2-16, 2-22
 - CRATEDLY keyword and field
 - monitoring 4-56, 4-124
 - tuning 6-21, 6-55
 - CSS (connectivity subsystem)
 - adapters 4-237
 - CLP (Communication Line Processor) 4-238
 - ESCON links
 - logical lines 2-22, 4-43
 - stations 2-22, 4-39
 - terminology xx
 - Token Ring
 - ATUTP1 Token-Ring TIC Details Page 1 panel 4-310, 6-170
 - ATUTP2 Token-Ring TIC Details Page 2 panel 4-319, 6-178
 - CX2 minor control block 4-19
 - CXB minor control block 4-19
 - CXI minor control block 4-19
 - Cycle/Buffer Utilization History panel 4-325
- ## D
- D bit 4-356
 - data circuit-terminating equipment (DCE) 4-356
 - data link connection identifier (DLCI)
 - address 4-89, 4-92, 4-93
 - ATUFS1 Frame Relay Switching Equipment Page 1 panel 4-128
 - definition of term X-7
 - list 2-22, 4-88
 - parameter table 4-92, 6-26
 - data terminal equipment (DTE) 4-356
 - definition of term X-7
 - data, saving to NetView log 3-11
 - DATABLK keyword and field
 - ATUFP2 Frame Relay Details Page 2 panel 4-118
 - ATUFP3 Frame Relay Details Page 3 panel 4-123
 - monitoring 4-55
 - datagrams, Internet router statistics 4-176
 - date stamp, beaconing 4-313
 - DATRATE tuning field
 - ATUSP1 SDLC Peripheral Line Parameters Page 1 panel 4-251, 6-126
 - cross-reference table 5-6
 - DCE (data circuit-terminating equipment) 4-356
 - DE (Discard Eligible) indicator
 - ATUDK2 panel 4-56, 6-20
 - ATUFP3 panel 4-123, 6-54
 - DE BITS RECEIVED monitoring field 4-145
 - DE BITS SENT monitoring field 4-145
 - DEBUG option 2-16
 - defining SDLC lines
 - See also* adding SDLC lines
 - redefinable line 7-6
 - spare line 7-5
 - dependent logical unit boundary session control block (LND) 4-20
 - destination service access point (DSAP) tuning field
 - ATUTL Token-Ring SNA Station panel 4-305, 6-165
 - diagnosing problems 2-25
 - dial information (NTuneMON) 4-109, 4-123
 - DIAL keyword and field
 - ATUFP Frame Relay Physical Line Details Page 1 panel 4-109
 - ATUFP3 Frame Relay Details Page 3 panel 4-123
 - DIAL monitoring field 4-119
 - disabling SDLC lines, redefinable 7-6
 - Discard Eligible (DE) indicator
 - ATUDK2 panel 4-56, 6-20
 - ATUFP3 panel 4-123, 6-54
 - disconnect mode 4-356
 - display messages 9-14
 - DLCI (data link connection identifier)
 - ATUFS1 Frame Relay Switching Equipment Page 1 panel 4-128
 - definition of term X-7
 - list 2-22, 4-88
 - DSAP (destination service access point) tuning field
 - ATUTL Token-Ring SNA Station panel 4-305, 6-165
 - DSCRDDLY keyword 6-55
 - DSCRDDLY keyword and field
 - monitoring 4-57, 4-124
 - tuning 6-22, 6-56
 - DTE (data terminal equipment) 4-356
 - definition of term X-7
 - DUPLEX tuning field
 - ATUSP1 SDLC Peripheral Line Parameters Page 1 panel 4-251, 6-126
 - cross-reference table 5-6
 - dynamic window size
 - See* DYNWIND() tuning fields

DYNPOOL keyword (DYNPOOL TOTAL tuning field)
 ATUBP NCP Buffer Pool panel 4-7, 6-5
 cross-reference table 5-6
 DYNPOOL TOTAL tuning field
 ATUBP NCP Buffer Pool panel 4-7, 6-5
 cross-reference table 5-6
 DYNWIND() tuning fields
 ATUFP Frame Relay Physical Line Details Page 1
 panel 4-111, 6-39
 ATUFT1 Frame Relay Terminating Equipment
 Details Page 1 panel 4-137, 6-67—6-71, 6-73
 ATUTL Token-Ring SNA Station panel 4-303,
 6-160
 ATUTP1 Token-Ring TIC Details Page 1
 panel 4-314, 6-171
 cross-reference table 5-6

E

EC level (MOSS microcode) 2-22
 ATUCD CDS NCP Selection panel 4-28
 ATUSS Summary Status panel 4-262
 Elapsed Time field 4-118
 Elapsed Time monitoring field 4-109
 Element Address monitoring field
 ATUPL SDLC Physical Line Details panel 4-220
 ATUXF NPSI Virtual Circuit Statistics panel 4-346
 ATUXH X.25 MCH Physical Line Statistics
 panel 4-348
 ATUXP X.25 MCH Physical Line Details Page 1
 panel 4-354, 4-359
 enabling SDLC spare line 7-5
 entering values in panel fields 3-7
 ERn keyword
See also LOW, MEDIUM, HIGH, TOTAL and QUED
 LMT tuning fields
 ATUML Multi-Link Transmission Group
 panel 4-186, 6-94
 cross-reference table 5-6
 error codes 5-16
 error messages 9-1
 ESCON links
 logical lines 2-22, 4-43
 stations 2-22, 4-39
 ESS (Ethernet-type subsystem) 2-22
 Ethernet Adapter List panel 4-81
 Ethernet Adapter Statistics panel 4-84
 Ethernet-type LAN
 frame counts 4-81, 4-85
 line names 2-22, 4-81
 statistics 4-84
 traffic rates 4-82, 4-85
 Ethernet-type subsystem (ESS) 2-22
 ETRATIO tuning field
 ATUSP2 SDLC Peripheral Line Parameters Page 2
 panel 4-256, 6-135
 ETRATIO tuning field (*continued*)
 cross-reference table 5-6
 examples
 ATUNELST CLIST data 2-10
 Authorized Users' List 2-11
 boundary pool use 4-6
 language statement X-8
 NCP definition statement X-8
 sample panel 3-7
 thresholds for resource use 3-9
 excluding NCPs
 ATUNEMON command 2-13
 VTAM definition statement X-8

F

FAST option 2-17
 Fast Transaction Processing Interface multichannel
 (FTPI MCH) monitoring field 4-354
 fast-path commands
 entering commands 3-4
 PL 4-217
 ROLL 3-5
 FCT (file control parameter table) 4-21
 FECN indicator 6-55, 6-56
 FECNS RECEIVED monitoring field 4-145
 FFDC (first failure data capture)
See ATUBS Buffer Slowdown Information Page 1
 panel, ATUBX Buffer Slowdown Information Page 2
 panel
 file control parameter table (FCT) 4-21
 first failure data capture (FFDC)
See ATUBS Buffer Slowdown Information Page 1
 panel, ATUBX Buffer Slowdown Information Page 2
 panel
 FIX level (MOSS microcode) 2-22
 ATUSS Summary Status panel 4-262
 FR LLB (frame-relay logical link block) 4-22
 frame counts (Ethernet-type LAN) 4-81, 4-85
 frame modulo 4-355
 frame relay
 ATUFA Frame Relay Support List panel 4-88
 ATUFB Frame Relay DLCI CIR Parameters
 panel 4-92, 6-26
 ATUFC Physical Line List panel 4-94
 ATUFD Frame Relay DLCI to Balance Table
 panel 4-99, 6-29
 ATUFI Frame-Relay IP Link Statistics panel 4-102
 ATUFL Frame Relay Multi Station List panel 4-105
 ATUFP Frame Relay Physical Line Details Page 1
 panel 4-108, 6-34
 ATUFP2 Frame Relay Details Page 2 panel 4-117,
 6-48
 ATUFP3 Frame Relay Details Page 3 panel 6-53
 ATUFS1 Frame Relay Switching Equipment Page 1
 panel 4-127, 6-61

Index

- frame relay (*continued*)
 - ATUFS2 Frame Relay Switching Equipment Page 2 panel 4-131
 - ATUFT1 Frame Relay Terminating Equipment Details Page 1 panel 4-135, 6-64
 - ATUFT2 Frame Relay Terminating Equipment Details Page 2 panel 4-143, 6-78
 - ATUTF NTRI Frame Handler Logical Lines panel 4-291
 - definition of term X-9
 - DLCI list 2-22
 - logical line counts 4-96
 - NTuneMON, use with 2-23
 - over Token-Ring 4-285, 6-152
 - stations list 4-88
 - subports list 4-88
 - tunable keywords 1-16
 - Frame Relay Details Page 2 panel 4-117
 - tuning 6-48
 - Frame Relay Details Page 3 panel
 - tuning 6-53
 - Frame Relay DLCI CIR Parameters panel 4-92
 - tuning 6-26
 - Frame Relay DLCI Stations List panel 4-105
 - Frame Relay DLCI to Balance Table panel 4-99
 - tuning 6-29
 - frame sizes (Token Ring) 4-280
 - Frame Window monitoring field 4-354, 4-359
 - Frame-Relay IP Link Statistics panel 4-102
 - tuning 6-32
 - frame-relay logical link block (FR LLB) 4-22
 - frame-relay panel group 1-9
 - Frame-Relay Physical Line Details panel 4-108, 6-34
 - Frame-Relay Subport List panel 4-88
 - frame-relay switching equipment (FRSE)
 - definition of term X-9
 - DLCI (data link connection identifier) 4-127
 - FRSEDRPU keyword on PUDRPOOL statement 4-23
 - Frame-Relay Switching Equipment Page 1 panel 4-127, 6-61
 - Frame-Relay Switching Equipment Page 2 panel 4-131
 - Frame-Relay Terminating Equipment Details Page 1 panel 4-135, 6-64
 - Frame-Relay Terminating Equipment Details Page 2 panel 4-143, 6-78
 - FRAMES DISCARDED monitoring field 4-145
 - FRAMES RECEIVED monitoring field 4-82
 - FRAMES TRANSMITTED monitoring fields 4-82
 - Free compared to FREE UNRSVD 4-47
 - FRRATES keyword 4-118, 4-123, 6-48
 - FRSE (frame-relay switching equipment)
 - definition of term X-9
 - DLCI (data link connection identifier) 4-127
 - FRSEDRPU keyword on PUDRPOOL statement 4-23
 - FRSPRI keyword
 - monitoring 4-74, 4-141
 - FRSPRI keyword and field 6-76
 - monitoring 4-57, 4-123
 - tuning 6-22, 6-24, 6-53, 6-62
 - FTPI MCH (Fast Transaction Processing Interface multi-channel) monitoring field 4-354
- ## G
- gateway network addressable unit (GWNAU)
 - and HSCBs 4-195
 - in use counts 4-158
 - in use counts, non-dynamic 4-161
 - names and HSCBs 4-192
 - use, overview 2-23
 - GENALERT command 9-9
 - GENALERT option 2-17
 - GENDATE (generation date) 4-205
 - generation date (GENDATE) 4-205
 - generation information 2-23
 - ATUNP NCP Selection panel 4-205
 - ATUSS Summary Status panel 4-261
 - generation level (GENLEVEL) 4-205
 - generic alerts
 - ATUBP NCP Buffer Pool panel 4-7
 - ATUCB Control Block Pools/Tables panel 4-24
 - ATUGP Network CB Pools/Tables panel 4-150
 - ATUNT NCP Network Names Table panel 4-210
 - definition of term X-10
 - GENALERT option 2-17
 - GWNAUs 4-160, 4-193
 - GWNAUs, non-dynamic 4-162
 - messages 8-1
 - SNI networks and HSCBs 4-202
 - SUMMARY panel 4-263, 4-265
 - Token-Ring 4-279
 - transmission groups 4-265, 4-295
 - virtual routes 4-263, 4-335
 - GENLEVEL (generation level) 4-205
 - global flow control parameters panel 4-153, 6-84
 - GLOBAL option 2-18
 - global variables
 - buffers and pools 4-7, 4-24, 4-150
 - Ethernet-type LAN 4-82, 4-85
 - GLOBAL option 2-18
 - RESET option 2-19
 - Token-Ring 4-279
 - transmission groups 4-265
 - virtual routes 4-264
 - glossary X-5
 - GWNAU (gateway network addressable unit)
 - and HSCBs 4-195
 - in use counts 4-158
 - in use counts, non-dynamic 4-161
 - names and HSCBs 4-192

GWNAU (gateway network addressable unit) (*continued*)

use, overview 2-23

GWNAU Names and HSCBs panel 4-192

GWNAUs In Use Counts panel 4-158

GWPACING keyword 4-151

tuning 6-81

H

half-session control block (HSCB)

and GWNAUs 4-195

in use counts 4-158

in use counts, non-dynamic 4-161

names and GWNAUs 4-192

networks and HSCB counts 4-201

use, overview 2-23

hardware requirements

NTuneMON 2-5

NTuneNCP 5-3

HDXSP tuning field

ATUSP2 SDLC Peripheral Line Parameters Page 2 panel 4-258, 6-144

cross-reference table 5-6

help, online, discussion of 2-11

HEX option 2-19

hexadecimal displays 2-19, 4-68

Hexadecimal Storage Display panel 4-68

HIGH tuning field

ATUML Multi-Link Transmission Group

panel 4-186, 6-94

summary status 4-265

transmission group 4-296

HISPEED tuning field

ATUPL SDLC Physical Line Details panel 4-219, 6-105

ATUSP1 SDLC Peripheral Line Parameters Page 1 panel 4-252, 6-127

cross-reference table 5-6

HLOQSTOP keyword and field

monitoring 4-56, 4-123

tuning 6-19, 6-54

host route entry pool (HRE) 4-22

HPR and Other Global Flow Control Parameters

panel 4-153, 6-84

HPR NLP ROUTE SNAP TRACE ENABLED tuning

field 4-270, 6-148

HPR ROUTE SETUP SNAP TRACE ENABLED tuning

field 4-271, 6-150

HPRATT keyword (HPRSATT tuning field)

ATUHP HPR & Other Global Flow Control Params

panel 4-153, 6-85

cross-reference table 5-6

HPRMLC keyword (HPRSMMLC tuning field)

ATUHP HPR & Other Global Flow Control Params

panel 4-153, 6-86

HPRMLC keyword (HPRSMMLC tuning field) (*continued*)

cross-reference table 5-6

HPRMPS keyword (HPRSMPS tuning field)

ATUHP HPR & Other Global Flow Control Params

panel 4-153, 6-84

cross-reference table 5-6

HPRQLIM tuning field

ATUSD SDLC Station Details panel 4-245, 6-120

cross-reference table 5-6

HPRSNAP tuning field

ATUST NCP Function Activation panel 4-270,

4-271, 6-148, 6-150

cross-reference table 1-18

HPTSS lines 6-36, 6-38

HRE (host route entry pool) 4-22

HSCB (half-session control block)

and GWNAUs 4-195

in use counts 4-158

in use counts, non-dynamic 4-161

names and GWNAUs 4-192

networks and HSCB counts 4-201

use, overview 2-23

HSCBs (Networks and HSCB Counts) panel 4-201

HSCBs and GWNAUs panel 4-195

I

IDBLK-IDNUM, specifying address (Token Ring) 2-16, 2-22, 4-74, 4-282

initial NTuneMON panels 1-6

input fields on panels 3-7

installing NTuneMON 2-8

Integrated Services Digital Network (ISDN)

monitoring 4-55

support 1-15

tuning 6-15, 6-19

Interface Address monitoring field 4-165

interface information, programming xvi

Interface Name monitoring field 4-165

internal 3746 Model 900 point-to-point IP

connection 4-176, 4-298

activation 4-181

Internet Protocol

See also TCP/IP

definition of term X-10

pool (IPPOOL) 1-17, 4-6

router statistics 2-23, 4-175

interwork 4-356

IP channel statistics panel 4-36

IP DATAGRAM SNAP TRACE ENABLED tuning field

ATUST NCP Function Activation panel 4-271,

6-149

IP Interface Information Details panel 4-164, 6-90

IP Interface Information panel 4-169

IP panel group 1-10

Index

IP ROUTE SNAP TRACE ENABLED tuning field
 ATUST NCP Function Activation panel 4-271, 6-150

IP Route Table Entries panel 4-172

IP Router Statistics Page 1 panel 4-175

IP Router Statistics Page 2 panel 4-180

IPPOOL and IPRATE 4-178

IPPOOL keyword
 See also TG threshold, tuning

 ATUBP NCP Buffer Pool panel 4-6, 6-4
 cross-reference table 5-6

IPQLIM keyword 4-103, 6-32

IPSNAP keyword
 See also IP DATAGRAM SNAPTRACE ENABLED, IP ROUTE SNAPTRACE ENABLED tuning fields
 cross-reference table 5-6
 NCP function activation 4-270, 4-271, 6-149, 6-150

ISDN (Integrated Services Digital Network)
 monitoring 4-55
 support 1-15
 tuning 6-15, 6-19

ISDN B-Channel Line Details panel 4-65

ISDN B-Channel Line List panel 4-62

ISDN backup information 4-115

ISDN panel group 1-15

ISDN Physical Line Details panel 4-49

ISDN Physical Line List panel 4-59

ISDN Station Details panel 4-73
 tuning 6-24

ISDN Stations List panel 4-71

J

JCL 5-5

K

keywords

 LOCADD

 ATUDS ISDN Stations Table List panel 4-71

keywords, NCP

 ACTIVTO

 ATUSP2 SDLC Peripheral Line Parameters Page 2 panel 6-135

 ADDR

 ATUTL Token-Ring SNA Station panel 6-164

 ADDRESS 4-122

 ATUFP3 Frame Relay Details Page 3 panel 4-122

 ADPLIMIT 4-154

 tuning 6-87

 ANSTONE

 ATUFP2 Frame Relay Details Page 2 panel 4-119, 6-49

 ATUSP1 SDLC Peripheral Line Parameters Page 1 panel 6-124

keywords, NCP (*continued*)

 ARPTAB

 ATUID IP Interface Information Detail panel 6-91

 AUTO 4-119

 BALANCE 6-174

 ATUFD Frame Relay DLCI to Balance Table panel 4-100, 6-29

 ATUTP1 Token-Ring TIC Details Page 1 panel 4-315

 BLOCK(bytes)

 ATUFT1 Frame Relay Terminating Equipment Details Page 1 panel 6-75

 ATUSD SDLC Station Details panel 6-119

 ATUTL Token-Ring SNA Station panel 6-167

 BLOCK(piis)

 ATUFT1 Frame Relay Terminating Equipment Details Page 1 panel 6-73

 ATUSD SDLC Station Details panel 6-114

 ATUTL Token-Ring SNA Station panel 6-160

 CCLID

 ATUSP1 SDLC Peripheral Line Parameters Page 1 panel 6-125

 CIR 4-53, 4-124, 6-15, 6-57

 CLOCKNG

 ATUED PEP Line Details panel 4-79

 ATUPL SDLC Physical Line Details panel 6-107

 ATUPS Bisync/SS Line Details panel 4-225

 ATUSP1 SDLC Peripheral Line Parameters Page 1 panel 6-125

 ATUXP X.25 MCH Physical Line Details Page 1 panel 4-355, 4-360, 6-193

 COMRATE 6-21, 6-55

 ATUDT ISDN Station Details panel 4-76

 ATUFS1 Frame Relay Switching Equipment Page 1 panel 6-61

 ATUFT1 Frame Relay Terminating Equipment Details Page 1 panel 6-65

 ATUFT2 Frame Relay Terminating Equipment Details Page 2 panel 6-78

 ATUTF NTRI Frame Handler Logical Lines panel 6-152

 ATUTP2 Token-Ring TIC Details Page 2 panel 6-178

 CRATEDLY 6-21, 6-55

 DATABLK

 ATUFP2 Frame Relay Details Page 2 panel 4-118

 ATUFP3 Frame Relay Details Page 3 panel 4-123

 DATRATE

 ATUSP1 SDLC Peripheral Line Parameters Page 1 panel 6-126

 DIAL 4-119

 ATUFP Frame Relay Physical Line Details Page 1 panel 4-109

 ATUFP3 Frame Relay Details Page 3 panel 4-123

keywords, NCP (*continued*)

DSCRDDLY 6-22, 6-55, 6-56
 DUPLEX
 ATUSP1 SDLC Peripheral Line Parameters Page
 1 panel 6-126
 DYNPOOL
 ATUBP NCP Buffer Pool panel 6-5
 DYNWIND()
 ATUFP Frame Relay Physical Line Details Page 1
 panel 6-42—6-43
 ATUFT1 Frame Relay Terminating Equipment
 Details Page 1 panel 6-67—6-71, 6-73
 ATUTL Token-Ring SNA Station panel 6-160
 ATUTP1 Token-Ring TIC Details Page 1
 panel 4-314, 6-171
 Token-Ring TIC details 6-171
 ERn
 ATUML Multi-Link Transmission Group
 panel 4-186, 6-94
 ETRATIO
 ATUSP2 SDLC Peripheral Line Parameters Page
 2 panel 6-135
 FRRATES 4-118, 6-48
 FRSPRI 4-123, 4-141, 6-22, 6-24, 6-53, 6-62, 6-76
 ATUDK2 ISDN Physical Line Details Page 2
 panel 4-57
 GWPACING 4-151
 tuning 6-81
 HDXP
 ATUSP2 SDLC Peripheral Line Parameters Page
 2 panel 6-144
 HISPEED
 ATUPL SDLC Physical Line Details panel 6-105
 ATUSP1 SDLC Peripheral Line Parameters Page
 1 panel 6-127
 HLOQSTOP 6-19, 6-54
 HPRATT
 ATUHP HPR & Other Global Flow Control Parm
 panel 6-85
 HPRMLC
 ATUHP HPR & Other Global Flow Control Parm
 panel 6-86
 HPRMPS
 ATUHP HPR & Other Global Flow Control Parm
 panel 6-84
 HPRQLIM
 ATUSD SDLC Station Details panel 4-245,
 6-120
 HPRSNAP 4-270, 6-148
 INTFACE 4-167
 IPPOOL
 ATUBP NCP Buffer Pool panel 6-4
 IPQLIM 4-103, 6-32
 IPSNAP
 NCP function activation 6-149, 6-150
 LMI
 ATUFP Frame Relay Physical Line Details Page 1
 panel 6-44

keywords, NCP (*continued*)

LMI (*continued*)
 ATUTF NTRI Frame Handler Logical Lines
 panel 6-153
 LOCADD
 ATUTL Token-Ring SNA Station panel 6-170
 LOCALTO
 ATUDT ISDN Station Details panel 4-76
 ATUFT1 Frame Relay Terminating Equipment
 Details Page 1 panel 6-71
 ATUTL Token-Ring SNA Station panel 6-157
 LSPRI
 ATUPL SDLC Physical Line Details panel 6-106
 ATUSP2 SDLC Peripheral Line Parameters Page
 2 panel 6-143
 MAXDATA
 ATUFT1 Frame Relay Terminating Equipment
 Details Page 1 panel 6-74
 ATUSD SDLC Station Details panel 6-118
 ATUTL Token-Ring SNA Station panel 6-165
 MAXDLCI 4-50, 4-110
 MAXFRAME
 ATUFP2 Frame Relay Details Page 2
 panel 4-118
 ATUTP2 Token-Ring TIC Details Page 2
 panel 4-320
 MAXOUT 4-147
 ATUFT1 Frame Relay Terminating Equipment
 Details Page 1 panel 6-74
 ATUSD SDLC Station Details panel 6-118
 ATUTL Token-Ring SNA Station panel 6-166
 MEMSIZE 4-358
 MLTGPRI
 ATUML Multi-Link Transmission Group
 panel 6-95
 MODULO
 ATUSD SDLC Station Details panel 6-119
 NCPTRACE
 NCP function activation 6-148
 NETID
 ATUCH Channel Adapter Details panel 4-34,
 6-10
 ATUCL 3746-900 Station Details panel 4-40,
 6-12
 ATUDT ISDN Station Details panel 4-74
 tuning 6-10, 6-12
 NEWSYNC
 ATUSP1 SDLC Peripheral Line Parameters Page
 1 panel 6-127
 NRZI
 ATUFP Frame Relay Physical Line Details Page 1
 panel 6-37
 ATUPL SDLC Physical Line Details panel 6-109
 ATUSP1 SDLC Peripheral Line Parameters Page
 1 panel 6-128
 ATUXP X.25 MCH Physical Line Details Page 1
 panel 4-355, 4-359, 6-192

Index

keywords, NCP (*continued*)

NTUNECOL
 ATUST NCP Function Activation panel 6-150
OWNERPL 4-117, 4-310
PASSLIM
 ATUSD SDLC Station Details panel 6-116
PAUSE
 ATUPL SDLC Physical Line Details panel 6-107
 ATUSP2 SDLC Peripheral Line Parameters Page
 2 panel 6-142
PIUCHECK
 ATUDT ISDN Station Details panel 6-25
 ATUFT1 Frame Relay Terminating Equipment
 Details Page 1 panel 4-140, 6-76
 ATUSD SDLC Station Details panel 4-244,
 6-120
 ATUTL Token-Ring SNA Station panel 4-308,
 6-167
QSIZE 6-20, 6-55
QSIZEDE 6-20, 6-54
QSZALERT 4-8, 6-7
REDIAL
 ATUFP2 Frame Relay Details Page 2
 panel 4-119, 6-50
 ATUSP2 SDLC Peripheral Line Parameters Page
 2 panel 6-136
REMOTTO
 ATUTL Token-Ring SNA Station panel 6-157
REPLYTO
 ATUMT Modify Timer Value panel 6-98
 ATUSP2 SDLC Peripheral Line Parameters Page
 2 panel 6-139
RETRIES
 ATUSD SDLC Station Details panel 6-115
 ATUSP2 SDLC Peripheral Line Parameters Page
 2 panel 6-138
RETRYTO
 ATUMT Modify Timer Value panel 6-99
 ATUSP2 SDLC Peripheral Line Parameters Page
 2 panel 4-257, 6-140
RING
 ATUFP2 Frame Relay Details Page 2
 panel 4-119, 6-49
 ATUSP1 SDLC Peripheral Line Parameters Page
 1 panel 6-128
RNRLIMT
 ATUSP2 SDLC Peripheral Line Parameters Page
 2 panel 6-136
SERVLIM
 ATUPL SDLC Physical Line Details panel 6-109
 ATUSP2 SDLC Peripheral Line Parameters Page
 2 panel 6-144
SPEED
 ATUFP Frame Relay Physical Line Details Page 1
 panel 6-35
 ATUPL SDLC Physical Line Details panel 6-103
 ATUSP1 SDLC Peripheral Line Parameters Page
 1 panel 6-129

keywords, NCP (*continued*)

SPEED (*continued*)
 ATUXP X.25 MCH Physical Line Details Page 1
 panel 6-190
SRETRY
 ATUSP2 SDLC Peripheral Line Parameters Page
 2 panel 6-136
SSAP
 ATUTL Token-Ring SNA Station panel 6-164
summary table 5-6
T1TIMER
 ATUDT ISDN Station Details panel 4-76
 ATUFT1 Frame Relay Terminating Equipment
 Details Page 1 panel 6-71
 ATUTL Token-Ring SNA Station panel 6-157
T2TIMER
 ATUDT ISDN Station Details panel 4-76
 ATUFT1 Frame Relay Terminating Equipment
 Details Page 1 panel 6-72
 ATUTL Token-Ring SNA Station panel 6-158
TEXTTO
 ATUMT Modify Timer Value panel 6-99
 ATUSP2 SDLC Peripheral Line Parameters Page
 2 panel 6-141
TGCONF 4-137, 4-138, 4-242, 4-303
 tuning 6-66, 6-71, 6-114, 6-159, 6-160
TGTIMER 4-339
 tuning 6-187
TITIMER
 ATUFP Frame Relay Physical Line Details Page 1
 panel 6-38
 ATUTP1 Token-Ring TIC Details Page 1
 panel 6-171
TRANSBUF 4-110, 6-38
TRANSFER
 ATUSP1 SDLC Peripheral Line Parameters Page
 1 panel 6-131
V25BIS 4-120
VRPWSnm
 ATUVA Virtual Route Control Block Details
 panel 6-182
VRTIMERn 4-339
 tuning 6-185
X21NTWK
 ATUSP1 SDLC Peripheral Line Parameters Page
 1 panel 6-132
X21SW 4-355
X25SNAP 4-270, 6-149
XMITDLY
 ATUMT Modify Timer Value panel 6-99
 ATUSP2 SDLC Peripheral Line Parameters Page
 2 panel 6-141

L

- LAC (line access control) trace 4-356
- LAE (local address entry) control blocks 4-23
- leased line 4-109
- legal notices xv
- licensing agreement xv
- line access control (LAC) trace 4-356
- Line Adapter monitoring field
 - ATUXD X.25 Virtual Circuit Details panel 4-343
 - ATUXP X.25 MCH Physical Line Details Page 1 panel 4-354, 4-359
- line adapter scanners 2-24, 4-233
- Line adapter type field 4-123
- Line Adapters Page 1 panel 4-233
- Line Adapters Page 2 panel 4-233
- Line Addr field 4-122
- Line Address field 4-55
- Line Address monitoring field
 - See also* ADDR monitoring field
 - See also* ADDRESS monitoring field
 - ATUDK ISDN Physical Line Details panel 4-50
 - ATUDN ISDN B-Channel Line Details panel 4-65
 - ATUDT ISDN Station Details panel 4-74
 - ATUET Ethernet Adapter Statistics panel 4-85
 - ATUFA Frame Relay Support List panel 4-89
 - ATUFI Frame-Relay IP Link Statistics panel 4-103
 - ATUTI Token-Ring IP Statistics panel 4-299
 - ATUTP1 Token-Ring TIC Details Page 1 panel 4-311
 - ATUXP X.25 MCH Physical Line Details Page 1 panel 4-354, 4-358
- Line Name field 4-55, 4-122
- Line Name monitoring field
 - See also* "line" under "Name monitoring field"
 - ATUDK ISDN Physical Line Details panel 4-50
 - ATUDN ISDN B-Channel Line Details panel 4-65
 - ATUDT ISDN Station Details panel 4-73
 - ATUFA Frame Relay Support List panel 4-89
 - ATUFP Frame Relay Physical Line Details Page 1 panel 4-109
 - ATUFS1 Frame Relay Switching Equipment Page 1 panel 4-128
 - ATUFT1 Frame Relay Terminating Equipment Details Page 1 panel 4-136
 - ATUFT2 Frame Relay Terminating Equipment Details Page 2 panel 4-144
 - ATUPL SDLC Physical Line Details panel 4-218
 - ATUTD NTRI Frame Handlers Logical Line Details panel 4-286
 - ATUTF NTRI Frame Handler Logical Lines panel 4-291
 - ATUXD X.25 Virtual Circuit Details panel 4-342
 - ATUXP X.25 MCH Physical Line Details Page 1 panel 4-354, 4-359
 - ATUXS X.25 MCH Physical Line Details Page 2 panel 4-363
- Line Speed monitoring field
 - See also* SPEED tuning field
 - ATUDK ISDN Physical Line Details panel 4-50
 - ATUFP Frame Relay Physical Line Details Page 1 panel 4-109
 - ATUPL SDLC Physical Line Details panel 4-218
 - ATUXD X.25 Virtual Circuit Details panel 4-343
 - ATUXP X.25 MCH Physical Line Details Page 1 panel 4-354, 4-359
- Line Speed tuning field
 - See also* SPEED tuning field
 - ATUXP X.25 MCH Physical Line Details Page 1 panel 6-190
- line status 4-123
- Line Status field 4-55
- Line Type field 4-123
- lines (Token-Ring)
 - logical names, specifying 2-15, 2-22, 4-282
 - status 4-286, 4-302
- link modulo 4-356
- LMI monitoring field 4-53, 4-67
- LMI tuning field
 - ATUFP Frame Relay Physical Line Details Page 1 panel 4-113, 6-44
 - ATUTD NTRI Frame Handlers Logical Line Details panel 4-288
 - ATUTF NTRI Frame Handler Logical Lines panel 4-288, 6-153
 - cross-reference table 5-6
- LNB (logical unit address control block) 4-20
- LND (dependent logical unit boundary session control block) 4-20
- LOCADD keyword
 - monitoring 4-71, 4-114, 4-279, 4-282, 4-298, 4-304, 4-311
 - tuning 6-170
- local address entry (LAE) control blocks 4-23
- local management interface (LMI), frame relay 4-113, 4-288, 6-44, 6-153
- LOCALTO keyword
 - ATUDT ISDN Station Details panel 4-76
 - ATUFT1 Frame Relay Terminating Equipment Details Page 1 panel 6-71
 - ATUTL Token-Ring SNA Station panel 6-157
 - cross-reference table 5-6
- Log BNN Conn monitoring field 4-315
- log, NetView, saving data 3-11
- logical unit address control block (LNB) 4-20
- logical unit control block (LUB) 4-19
- logical unit terminal node extension control block (LTX) 4-20
- loop, endless 4-270
- LOW tuning field
 - ATUML Multi-Link Transmission Group panel 4-186, 6-94
 - ATUTG Transmission Group panel 4-295

Index

- LOW tuning field (*continued*)
 - summary status 4-265
 - LSPRI tuning field
 - ATUFP Frame Relay Physical Line Details Page 1 panel 4-219, 6-106
 - ATUPL SDLC Physical Line Details panel 4-258, 6-143
 - cross-reference table 5-6
 - LTX (logical unit terminal node extension control block) 4-20
 - LU control block extension (LXE) 4-24
 - LUB (logical unit control block) 4-19
 - LUX (XRF logical unit block extension) 4-21
 - LXE (LU control block extension) 4-24
- ## M
- MAC address
 - ATUEP Ethernet Adapter List panel 4-82
 - ATUET Ethernet Adapter Statistics panel 4-84
 - ATUFT1 Frame Relay Terminating Equipment Details Page 1 panel 4-141
 - ATUTA Token-Ring SNA Station List panel 4-274
 - ATUTC Token-Ring Adapter List panel 4-279, 4-282
 - ATUTD NTRI Frame Handlers Logical Line Details panel 4-287, 6-153
 - ATUTF NTRI Frame Handler Logical Lines panel 4-292
 - ATUTI Token-Ring IP Statistics panel 4-298
 - ATUTL Token-Ring SNA Station panel 4-304, 4-305, 6-164
 - ATUTP1 Token-Ring TIC Details Page 1 panel 4-311, 6-170
 - monitoring 2-16, 2-22, 6-175
 - Max DLCI monitoring field
 - ATUDK ISDN Physical Line Details panel 4-50
 - ATUFP Frame Relay Physical Line Details Page 1 panel 4-110
 - ATUTD NTRI Frame Handlers Logical Line Details panel 4-287
 - Max Frame monitoring field
 - ATUDK ISDN Physical Line Details panel 4-50
 - ATUXP X.25 MCH Physical Line Details Page 1 panel 4-356, 4-360
 - MAXDATA CUR
 - ATUDT ISDN Station Details panel 4-75
 - ATUFT1 Frame Relay Terminating Equipment Details Page 1 panel 4-139
 - ATUSD SDLC Station Details panel 4-244
 - ATUTL Token-Ring SNA Station panel 4-307
 - MAXDATA GEN tuning field
 - ATUDT ISDN Station Details panel 4-75
 - ATUFT1 Frame Relay Terminating Equipment Details Page 1 panel 4-139, 6-74
 - ATUSD SDLC Station Details panel 4-244, 6-118
 - MAXDATA GEN tuning field (*continued*)
 - ATUTL Token-Ring SNA Station panel 4-307, 6-165
 - cross-reference table 5-6
 - MAXDLCI keyword 4-50, 4-110
 - MAXFRAME keyword and field
 - ATUFP2 Frame Relay Details Page 2 panel 4-118
 - ATUTP2 Token-Ring TIC Details Page 2 panel 4-320
 - MAXOUT CUR
 - ATUDT ISDN Station Details panel 4-75
 - ATUFT1 Frame Relay Terminating Equipment Details Page 1 panel 4-139, 4-147
 - ATUSD SDLC Station Details panel 4-244
 - ATUTL Token-Ring SNA Station panel 4-307
 - MAXOUT GEN tuning field
 - ATUDT ISDN Station Details panel 4-75
 - ATUFT1 Frame Relay Terminating Equipment Details Page 1 panel 4-140, 6-74
 - ATUSD SDLC Station Details panel 4-244, 6-118
 - ATUTL Token-Ring SNA Station panel 4-307, 6-166
 - cross-reference table 5-6
 - MAXOUT keyword 4-147
 - MAXTSL frame sizes (Token Ring)
 - ATUTC Token-Ring Adapter List panel 4-280
 - frame information 4-313
 - frame statistics 4-306
 - segment sizes 6-84
 - MCH link 4-356
 - MCH Name monitoring field 4-355
 - MEDIUM tuning field
 - ATUML Multi-Link Transmission Group panel 4-186, 6-94
 - ATUTG Transmission Group panel 4-296
 - summary status 4-265
 - MEM
 - ATUCD CDS NCP Selection panel 4-28
 - ATUNW NCP Wide Selection panel 4-213
 - MEMSIZE, on BUILD statement
 - See also* MEM
 - ATUBP NCP Buffer Pool panel 4-6
 - ATUCD CDS NCP Selection panel 4-28
 - ATUNW NCP Wide Selection panel 4-213
 - ATUXP X.25 MCH Physical Line Details Page 1 panel 4-358
 - summary status 4-261
 - messages
 - display 9-14
 - error 9-1
 - information 9-1
 - Internet router datagrams 4-176
 - microcode
 - See* MOSS microcode levels
 - minimum working-window value
 - monitoring 4-112, 4-140

- minimum working-window value (*continued*)
 - tuning 6-43, 6-76
- MLTGPRI keyword 1-16
 - See also* PRI tuning field
- ATUML Multi-Link Transmission Group panel 6-95
 - cross-reference table 5-6
- MODE field
 - ATUFT1 Frame Relay Terminating Equipment
 - Details Page 1 panel 4-139
 - ATUSD SDLC Station Details panel 4-242
 - ATUTL Token-Ring SNA Station panel 4-303
- Modify Timer Value panel 4-189, 6-97
- MODULO keyword
 - See also* MAXOUT GEN tuning field
 - ATUSD SDLC Station Details panel 6-119
 - cross-reference table 5-6
- modulo-128 line
 - ATUFT1 Frame Relay Terminating Equipment
 - Details Page 1 panel 6-75
 - ATUPL SDLC Physical Line Details panel 4-220, 6-108
 - ATUSP2 SDLC Peripheral Line Parameters Page 2 panel 4-258, 6-142
 - ATUTL Token-Ring SNA Station panel 6-166
- modulo-8 line
 - ATUPL SDLC Physical Line Details panel 4-220, 6-107
 - ATUSP2 SDLC Peripheral Line Parameters Page 2 panel 4-258, 6-142
- monitoring 4-1—4-370
- monitoring fields
 - #PIUs/BLOCK
 - ATUFT1 Frame Relay Terminating Equipment
 - Details Page 1 panel 4-138
 - ATUSD SDLC Station Details panel 4-242
 - ATUTL Token-Ring SNA Station panel 4-303
 - ADDR
 - See also* ADDRESS monitoring field
 - See also* Line Address monitoring field
 - ATUCS 3746-900 Logical Lines panel 4-44
 - ATUDL ISDN Physical Line Table panel 4-60
 - ATUDM ISDN B-Channel Line Table panel 4-63
 - ATUFC Physical Line List panel 4-95
 - ATUSL SDLC Stations List panel 4-247
 - ATUXL X.25 MCH Physical Line List panel 4-351
 - ADDRESS 4-313
 - See also* ADDR monitoring field
 - See also* Line Address monitoring field
 - ATUDM ISDN B-Channel Line Table panel 4-62
 - ATUNI NTuneNCP Information panel 4-200
 - ALERT CNT 4-8
 - ALERT THRS
 - ATUBP NCP Buffer Pool panel 4-7
 - ATUCB Control Block Pools/Tables panel 4-24
 - ATUGP Network CB Pools/Tables panel 4-150
 - ATUIS IP Router Statistics Page 1 panel 4-178
- monitoring fields (*continued*)
 - ALERT% 4-8
 - ARP Address 4-166
 - AUTO 4-119
 - BDGLF 4-302
 - BECNS RECEIVED 4-145
 - BECNS SENT 4-145
 - BLOCK Gen
 - ATUFT1 Frame Relay Terminating Equipment
 - Details Page 1 panel 4-140
 - ATUSD SDLC Station Details panel 4-244
 - ATUTL Token-Ring SNA Station panel 4-307
 - BPOOL
 - ATUBP NCP Buffer Pool panel 4-5, 4-6, 4-7
 - congestion, virtual routes 4-335
 - summary status 4-262
 - Buffers
 - ATUBP NCP Buffer Pool panel 4-6
 - ATUSS Summary Status panel 4-262
 - ATUXL X.25 MCH Physical Line List panel 4-351
 - ATUXP X.25 MCH Physical Line Details Page 1 panel 4-354, 4-358
 - CCU (central control unit) usage
 - ATUBP NCP Buffer Pool panel 4-4
 - ATUBS Buffer Slowdown Information Page 1 panel 4-10
 - ATUCB Control Block Pools/Tables panel 4-19
 - ATUNW NCP Wide Selection panel 4-213
 - ATUPL SDLC Physical Line Details panel 4-218
 - ATUSS Summary Status panel 4-260
 - ATUUT NCP Utilization panel 4-329
 - ATUXL X.25 MCH Physical Line List panel 4-351
 - central control unit
 - See* CCU monitoring field
 - COMRATE
 - ATUDT ISDN Station Details panel 4-76
 - ATUFS1 Frame Relay Switching Equipment Page 1 panel 4-128
 - ATUFT1 Frame Relay Terminating Equipment
 - Details Page 1 panel 4-136, 4-137, 4-145
 - ATUTD NTRI Frame Handlers Logical Line
 - Details panel 4-286
 - ATUTF NTRI Frame Handler Logical Lines
 - panel 4-292
 - ATUTP2 Token-Ring TIC Details Page 2 panel 4-321
 - CONGESTION
 - ATUFT1 Frame Relay Terminating Equipment
 - Details Page 1 panel 4-137
 - ATUSD SDLC Station Details panel 4-242
 - ATUTL Token-Ring SNA Station panel 4-303
 - DE BITS RECEIVED 4-145
 - DE BITS SENT 4-145
 - destination service access point (DSAP)
 - ATUFA Frame Relay Support List panel 4-90

Index

monitoring fields *(continued)*

destination service access point (DSAP) *(continued)*

- ATUTA Token-Ring SNA Station List panel 4-274
- ATUTL Token-Ring SNA Station panel 4-305, 6-165

DIAL 4-119

DSAP (destination service access point)

- ATUFA Frame Relay Support List panel 4-90
- ATUTA Token-Ring SNA Station List panel 4-274
- ATUTL Token-Ring SNA Station panel 4-305, 6-165

DYNPOOL 4-7

DYNWIND()

- ATUFP Frame Relay Physical Line Details Page 1 panel 6-39
- ATUFT1 Frame Relay Terminating Equipment Details Page 1 panel 4-139
- ATUTL Token-Ring SNA Station panel 4-303
- ATUTP1 Token-Ring TIC Details Page 1 panel 4-314

Fast Transaction Processing Interface multichannel (FTPI MCH) 4-354

FECNS RECEIVED 4-145

Frame Window 4-354, 4-359

FRAMES DISCARDED 4-145

FTPI MCH (Fast Transaction Processing Interface multichannel) 4-354

GWNAU ALARM 4-196

HDXSP 4-258

HIGH 4-186, 4-265, 4-296

HISPEED

- ATUPL SDLC Physical Line Details panel 4-219

- ATUSP1 SDLC Peripheral Line Parameters Page 1 panel 4-252

HPRSATT 4-153

HPRMLC 4-153

HPRSMPS 4-153

IP PASSLIM 4-312

IPPOOL 4-6

Line Adapter

- ATUXD X.25 Virtual Circuit Details panel 4-343
- ATUXP X.25 MCH Physical Line Details Page 1 panel 4-354, 4-359

Line Address monitoring field

See also ADDR monitoring field

See also ADDRESS monitoring field

- ATUDK ISDN Physical Line Details panel 4-50
- ATUDN ISDN B-Channel Line Details panel 4-65
- ATUDT ISDN Station Details panel 4-74
- ATUET Ethernet Adapter Statistics panel 4-85
- ATUFA Frame Relay Support List panel 4-89
- ATUFI Frame-Relay IP Link Statistics panel 4-103
- ATUTI Token-Ring IP Statistics panel 4-299
- ATUTP1 Token-Ring TIC Details Page 1 panel 4-311

monitoring fields *(continued)*

Line Address monitoring field *(continued)*

- ATUXP X.25 MCH Physical Line Details Page 1 panel 4-354, 4-358

Line Name

See also "line" under "Name monitoring field"

- ATUDK ISDN Physical Line Details panel 4-50
- ATUDN ISDN B-Channel Line Details panel 4-65
- ATUDT ISDN Station Details panel 4-73
- ATUFA Frame Relay Support List panel 4-89
- ATUFP Frame Relay Physical Line Details Page 1 panel 4-109
- ATUFS1 Frame Relay Switching Equipment Page 1 panel 4-128
- ATUFT1 Frame Relay Terminating Equipment Details Page 1 panel 4-136
- ATUFT2 Frame Relay Terminating Equipment Details Page 2 panel 4-144
- ATUPL SDLC Physical Line Details panel 4-218
- ATUD NTRI Frame Handlers Logical Line Details panel 4-286
- ATUTF NTRI Frame Handler Logical Lines panel 4-291
- ATUXD X.25 Virtual Circuit Details panel 4-342
- ATUXP X.25 MCH Physical Line Details Page 1 panel 4-354, 4-359
- ATUXS X.25 MCH Physical Line Details Page 2 panel 4-363

LMI

- ATUFP Frame Relay Physical Line Details Page 1 panel 4-113
- ATUTF NTRI Frame Handler Logical Lines panel 4-288

Log BNN Conn 4-315

LOW 4-186, 4-265, 4-295

LSPRI 4-219

- ATUFP Frame Relay Physical Line Details Page 1 panel 4-219

ATUPL SDLC Physical Line Details panel 4-258

MAXDATA

- ATUDT ISDN Station Details panel 4-75
- ATUFT1 Frame Relay Terminating Equipment Details Page 1 panel 4-139
- ATUSD SDLC Station Details panel 4-244
- ATUTL Token-Ring SNA Station panel 4-307

MAXFRAME

- ATUFP2 Frame Relay Details Page 2 panel 4-118
- ATUTP2 Token-Ring TIC Details Page 2 panel 4-320

MAXOUT

- ATUDT ISDN Station Details panel 4-75
- ATUFT1 Frame Relay Terminating Equipment Details Page 1 panel 4-139, 4-147
- ATUSD SDLC Station Details panel 4-244
- ATUTL Token-Ring SNA Station panel 4-307

monitoring fields (*continued*)

MEDIUM 4-186, 4-265, 4-296
 MODE
 ATUFT1 Frame Relay Terminating Equipment
 Details Page 1 panel 4-139
 ATUSD SDLC Station Details panel 4-242
 ATUTL Token-Ring SNA Station panel 4-303
 N3GEN
 ATUDT ISDN Station Details panel 4-76
 ATUFT1 Frame Relay Terminating Equipment
 Details Page 1 panel 4-138
 ATUTL Token-Ring SNA Station panel 4-303
 Name (of)
 B-channel 4-63
 ESCON physical line 4-43
 ISDN physical line 4-60
 line 4-32
 logical line 4-40, 4-44
 logical station 4-72
 LU 4-15
 MCH 4-355
 physical line 4-39, 4-95
 PU 4-44, 4-247
 SDLC physical line 4-246
 session partner 4-16
 station 4-15
 X.25 MCH physical line 4-346, 4-348, 4-351
 NCP USE 4-250, 6-123
 NPSI Version 4-351
 NRZI
 ATUFP Frame Relay Physical Line Details Page 1
 panel 4-110
 ATUPL SDLC Physical Line Details panel 4-220
 ATUSP1 SDLC Peripheral Line Parameters Page
 1 panel 4-252
 OWNERPL 4-49, 4-310
 PASSLIM 4-244, 4-247
 PAUSE
 ATUPL SDLC Physical Line Details panel 4-220
 ATUSP2 SDLC Peripheral Line Parameters Page
 2 panel 4-258
 PRI 4-186
 Primary Host IP Owner 4-167
 PU name
 ATUCH Channel Adapter Details panel 4-33
 ATUCL 3746-900 Station Details panel 4-40
 ATUFS1 Frame Relay Switching Equipment Page
 1 panel 4-128
 ATUFT1 Frame Relay Terminating Equipment
 Details Page 1 panel 4-136
 ATUFT2 Frame Relay Terminating Equipment
 Details Page 2 panel 4-144
 ATUSD SDLC Station Details panel 4-241
 PU status 4-113, 4-141, 4-288
 ATUCH Channel Adapter Details panel 4-33
 ATUCL 3746-900 Station Details panel 4-40
 ATUSD SDLC Station Details panel 4-242

monitoring fields (*continued*)

QUED LMT 4-186
 REPLYTO
 ATUMT Modify Timer Value panel 4-190
 ATUSP2 SDLC Peripheral Line Parameters Page
 2 panel 4-257
 RETRIES
 ATUSD SDLC Station Details panel 4-243
 ATUSP2 SDLC Peripheral Line Parameters Page
 2 panel 4-256
 RETRYTO
 ATUMT Modify Timer Value panel 4-190
 ATUSP2 SDLC Peripheral Line Parameters Page
 2 panel 4-257
 RING 4-252
 SAP (source service access point)
 See DSAP tuning field, SSAP tuning field
 SERVLIM
 ATUPL SDLC Physical Line Details panel 4-220
 ATUSP2 SDLC Peripheral Line Parameters Page
 2 panel 4-258
 SNA Passlim 4-312
 source service access point (SAP)
 See DSAP tuning field, SSAP tuning field
 source service access point (SSAP) 4-304, 6-164
 SPEED
 ATUFP Frame Relay Physical Line Details Page 1
 panel 4-109
 ATUPL SDLC Physical Line Details panel 4-218
 ATUSP1 SDLC Peripheral Line Parameters Page
 1 panel 4-252
 SRETRY 4-256
 SSAP (source service access point) 4-304, 6-164
 STATION
 ATUFT1 Frame Relay Terminating Equipment
 Details Page 1 panel 4-138
 ATUSD SDLC Station Details panel 4-242
 ATUTL Token-Ring SNA Station panel 4-303
 Status (of)
 B-channel 4-63, 4-66
 B-channel station 4-67
 ESCON physical line 4-39
 Ethernet adapter 4-84
 frame-relay line 4-110
 IP interface 4-165
 IPSP 4-102
 ISDN logical line 4-72
 ISDN logical station 4-74
 ISDN physical line 4-60, 4-62
 logical line 4-40, 4-44
 logical station 4-344
 MLTG line 4-187
 physical line 4-32, 4-44, 4-96
 PU 4-247
 route 4-173
 SDLC peripheral line 4-250
 SDLC physical line 4-219, 4-246

Index

monitoring fields *(continued)*

Status (of) *(continued)*

station 4-37

TIC 4-274, 4-298, 4-311

Token-Ring physical line 4-281

virtual circuit 4-367

X.25 physical line 4-342, 4-351, 4-354, 4-358

T/R Address 4-305

T/R LOCADD 4-311

T1 Timer 4-76, 4-138

T1LOC 4-302

T1REM 4-302

T2 Timer 4-138

T2LOC 4-302

T2REM 4-302

TEXTO

ATUMT Modify Timer Value panel 4-190

ATUSP2 SDLC Peripheral Line Parameters Page
2 panel 4-257

TG thresholds 4-265, 4-295

TGCONF 4-137

THRESHOLD 4-160, 4-162

time stamp 4-313

TITIMER

ATUFP Frame Relay Physical Line Details Page 1
panel 4-110

ATUTP1 Token-Ring TIC Details Page 1
panel 4-314

TOTAL 4-186, 4-265, 4-296

TP Timer 4-354

TSLOW CNT 4-8

TSLOW% 4-8

Type (of)

channel adapter 4-32, 4-231

communication adapter 4-238

connection 4-165

DLCI 4-89

ESCP adapter 4-39, 4-43

line 4-186

line adapter 4-234

physical line 4-96

PU 4-44, 4-247

station 4-281

X.25 resource 4-351

UNIQUE 4-305, 6-164

V25BIS 4-120

VTAM USE 4-250

XMITDLY

ATUMT Modify Timer Value panel 4-190

ATUSP2 SDLC Peripheral Line Parameters Page
2 panel 4-257

MOSS microcode levels

EC 2-22, 4-28, 4-262

FIX 2-22, 4-28, 4-262

Multi-Link Transmission Group panel 4-184, 6-93

multicast frames 4-82, 4-85

multilink transmission group 1-16, 2-4

See also MLTGPR1 keyword

definition of term X-12

multiplexed stations 4-89, 4-90

MVS, NTuneMON on 2-8

MVS/ESA 5-4

MVS/ESA publications X-24

N

N/A (not applicable), what it means on a panel 3-9

N3GEN tuning field

ATUdT ISDN Station Details panel 4-76

ATUFT1 Frame Relay Terminating Equipment
Details Page 1 panel 4-138, 6-72

ATUTL Token-Ring SNA Station panel 4-303,
6-159

Name monitoring field

B-channel 4-63

ESCON physical line 4-43

ISDN physical line 4-60

line 4-32

See also Line Name monitoring field

logical line 4-40, 4-44

logical station 4-72

LU 4-15

physical line 4-39, 4-95

PU 4-40, 4-44, 4-247

SDLC physical line 4-246

session partner 4-16

station 4-15

X.25 MCH physical line 4-346, 4-348, 4-351

NCCFLIST (file type) 2-9

NCP Buffer Pool panel 4-4, 6-4

NCP Function Activation panel 4-269, 6-147

NCP Network Names Table panel 4-209

NCP PATH statement

use with VRPWS keyword 6-182, 6-183

NCP Selection panel 4-204

NCP tuning keywords

See keywords, NCP

NCP USE tuning field (USE keyword)

ATUSP1 SDLC Peripheral Line Parameters Page 1
panel 4-250, 6-123

cross-reference table 5-6

NCP Utilization panel 4-328

NCP Wide Selection panel 4-212

NCP, sample definition statement X-8

NCPs

excluding 2-13

FAST option 2-17

generation information 4-205, 4-261

TYPE=GEN 2-23

logical line names, specifying (Token Ring) 2-15,
2-22, 4-282

- NCPs (*continued*)
 - selecting 2-12, 4-204
- NCPTTRACE keyword
 - See also* NTRI/FRAME RELAY SNAP TRACE ENABLED tuning field
 - ATUST NCP Function Activation panel 6-148
 - cross-reference table 5-6
- NDRS (non-disruptive route switching)
 - messages 9-11
- NDRS (nondisruptive route switching) 4-308, 6-168
- NETID keyword
 - ATUCH Channel Adapter Details panel 4-34, 6-10
 - ATUCL 3746-900 Station Details panel 4-40, 6-12
 - ATUDT ISDN Station Details panel 4-74
 - tuning 6-10, 6-12
- NetView level required 2-5
- NetView log, saving data 3-11
- NetView procedure, adding NTuneMON libraries 2-8
- NetView publications X-22
- NetView, relationship to NTuneMON 3-6, 3-11
 - diagram 2-3
- Network CB Pools/Tables panel 4-149
 - tuning 6-81
- network names
 - ATUNT NCP Network Names Table panel 2-24
 - CPNAMEs 4-209, 4-282
 - TYPE option 2-22
 - GWNAUs (gateway networks)
 - ATUIB GWNAUs in Use Counts panel 4-158
 - ATUIC Non-Dynamic GWNAUs in Use Counts panel 4-161
 - ATUNA GWNAU Names and HSCBs panel 4-192
 - ATUNN HSCBs (Networks and HSCB Counts) panel 4-201
 - option table 2-23
 - NETWORK option 2-19
 - option table 2-23
 - SNI
 - ATUIB GWNAUs in Use Counts panel 4-158
 - ATUIC Non-Dynamic GWNAUs in Use Counts panel 4-161
 - ATUNA GWNAU Names and HSCBs panel 4-192
 - ATUNN HSCBs (Networks and HSCB Counts) panel 4-201
 - ATUNT NCP Network Names Table panel 4-209
 - option table 2-23
 - network names table (NNT) 4-21
 - NETWORK option 2-19
 - network route entry pool (NRE) 4-22
 - Network Type monitoring field (NPSI) 4-356
 - network vector table (NVT) 4-23
 - NEWNAME keyword 4-28
 - NEWSYNC tuning field
 - ATUSP1 SDLC Peripheral Line Parameters Page 1 panel 4-252, 6-127
 - NEWSYNC tuning field (*continued*)
 - cross-reference table 5-6
 - NNT (network names table) 4-21
 - non-disruptive route switching (NDRS)
 - messages 9-11
 - Non-Dynamic GWNAUs In Use Counts panel 4-161
 - nondisruptive route switching (NDRS) 4-308, 6-168
 - not applicable (N/A), what it means on a panel 3-9
 - not available (-), what it means on a panel 3-9
 - Notices xv
 - NPA counter queue element extensions (NQX) 4-23
 - NPA counter queue elements (NQE) 4-23
 - NPA session counter extension control block (NSC) 4-21
 - NPA session counters control block (NSC) 4-21
 - NPM frame-relay physical station data block (NSB) 4-23
 - NPM publications X-23
 - NPSI publications X-22
 - NPSI SNAP TRACE ENABLED tuning field 4-270, 6-149
 - NPSI Version monitoring field 4-351
 - NPSI Virtual Circuit Statistics panel 4-346
 - NQE (NPA counter queue elements) 4-23
 - NQX (NPA counter queue element extensions) 4-23
 - NRE (network route entry pool) 4-22
 - NRF publications X-23
 - NRZI keyword and field
 - ATUFP Frame Relay Physical Line Details Page 1 panel 4-110, 6-37
 - ATUPL SDLC Physical Line Details panel 4-220, 6-109
 - ATUSP1 SDLC Peripheral Line Parameters Page 1 panel 4-252, 6-128
 - ATUXP X.25 MCH Physical Line Details Page 1 panel 4-355, 4-359, 6-192
 - cross-reference table 5-6
 - NSA control block 4-11
 - NSB (NPM frame-relay physical station data block) 4-23
 - NSC (NPA session counters control block) 4-21
 - NSP control block 4-11
 - NSX (NPA session counter extension control block) 4-21
 - NTO publications X-23
 - NTRI Frame Handler Logical Line Details panel 4-285, 6-152
 - NTRI Frame Handler Logical Lines panel 4-291
 - NTRI/FRAME RELAY SNAP TRACE ENABLED
 - NCP function activation 4-270, 6-148
 - NTune
 - See* NTuneMON, NTuneNCP
 - NTUNECOL tuning field
 - ATUST NCP Function Activation panel 4-271, 6-150
 - cross-reference table 5-6

Index

NTuneMON

- ATUNELST CLIST 2-9
- authorizing users (ATUNELST CLIST) 2-9
- command options 2-13
- hardware and software requirements 2-5
- installing 2-8
- introduction 2-3
- moving between panels 3-3
- online help 2-11
- problem solving 2-25
- publications X-22
- saving data to NetView log 3-11
- set up 2-5
- starting 2-12

NTuneMON alerts 8-1

NTuneMON CLIST

See ATUNELST (authorized users' list)

NTUNEMON command options

- ADDR 2-15
- DEBUG 2-16
- FAST 2-17
- GENALERT 2-17
- GLOBAL 2-18
- HEX 2-19
- NETWORK 2-19
- OUTPUT 2-15
- RESET 2-19
- SCOPE 2-20
- SUBAREA 2-21
- TGN 2-21
- TYPE 2-21

NTuneMON panels

See index entries beginning with "ATU"

NTuneNCP

- authorizing users 5-6
- generating 5-4
- introduction 5-3
- modifiable functions 1-15
- overview 1-15
- publication X-22
- requirements 5-3
- setting up 5-4
- tuning your network 5-6

NTuneNCP Information panel 4-199

number-of-subareas control block (NUMHSAS) 4-20

NUMHSAS (number-of-subareas control block) 4-20

NVT (network vector table) 4-23

O

ODLC LAN logical resources 4-21

ODLC SNAP TRACE ENABLED

- ATUST NCP Function Activation panel 4-270, 6-148

online help 2-11

options

See NTUNEMON command options

OS/390 5-4

OUTBOUND QUEUE SIZE Maximum tuning field 4-103, 6-32

OUTPUT option 2-15

overtyping panel field values 3-7

OWNERPL Function Active field 4-117

OWNERPL Function Active monitoring field ATUDK ISDN Physical Line Details panel 4-49

OWNERPL keyword 4-117

OWNERPL monitoring field

- ATUTP1 Token-Ring TIC Details Page 1 panel 4-310

Owning Host monitoring field 4-47

P

padding window 4-45

panel groupings

- BSC/SS/PEP panels 1-7
- channel adapter panels 1-8
- frame-relay panels 1-9
- initial NTuneMON panels 1-6
- IP panels 1-10
- ISDN panels 1-15
- SDLC panels 1-11
- Token-Ring panels 1-12
- virtual route panels 1-13
- X.25 panels 1-14

panel, example of use 3-7, 3-8

panels, NTuneMON

See index entries beginning with "ATU", tuning panels

PASSLIM keyword (PASSLIM GEN tuning field)

- ATUSD SDLC Station Details panel 4-244, 6-116
- cross-reference table 5-6

path switching 4-308, 6-168

messages 9-11

PAUSE tuning field

- ATUPL SDLC Physical Line Details panel 4-220, 6-142

- ATUSP2 SDLC Peripheral Line Parameters Page 2 panel 4-258, 6-107

cross-reference table 5-6

PEP Line Details panel 4-78

PF Keys, use of 3-3, 4-1

Physical Line List panel 4-94

physical Token-Ring lines

See Token-Ring

physical unit dynamic reconfiguration pool (PUDR) 4-19

pink highlighting 4-306, 5-15

PIUCHECK keyword

- ATUFT1 Frame Relay Terminating Equipment Details Page 1 panel 4-140

- PIUCHECK keyword (*continued*)
 - ATUSD SDLC Station Details panel 4-244
 - ATUTL Token-Ring SNA Station panel 4-308
 - PIUCHECK keyword and field
 - ATUDT ISDN Station Details panel 6-25
 - ATUFT1 Frame Relay Terminating Equipment Details Page 1 panel 6-76
 - ATUSD SDLC Station Details panel 6-120
 - ATUTL Token-Ring SNA Station panel 6-167
 - monitoring 4-76
 - PIUs, flow of 4-45
 - PIUs/BLOCK
 - See #PIUs/BLOCK tuning field
 - PIUs/BLOCK tuning field
 - ATUFT1 Frame Relay Terminating Equipment Details Page 1 panel 4-138, 6-73
 - ATUSD SDLC Station Details panel 4-242, 6-114
 - ATUTL Token-Ring SNA Station panel 4-303, 6-160
 - PL fast-path command 4-217
 - polling data 4-34, 4-221, 4-243
 - pool, boundary (BPOOL)
 - ATUBP NCP Buffer Pool panel 4-6, 4-7
 - congestion, virtual routes 4-335
 - full 4-5
 - summary status 4-262
 - pools, control block 4-19
 - port address
 - adapter list 4-279
 - option table 2-25
 - TIC details 4-310, 4-319, 6-170, 6-178
 - port number 4-139
 - pre-SNA resource
 - ATUPT Bisync/Start Stop Device List panel 4-227
 - pre-SNA resources
 - ATUED PEP Line Details panel 4-78
 - ATUPS Bisync/SS Line Details panel 4-223
 - PRI (link priority) tuning field
 - ATUML Multi-Link Transmission Group panel 4-186, 6-95
 - Primary Host IP Owner monitoring field 4-167
 - PRIORITY field
 - monitoring 4-127
 - Priority tuning field 4-118, 6-48
 - problem solving 2-16, 2-25
 - programming interface information xvi
 - PU name monitoring field
 - ATUCH Channel Adapter Details panel 4-33
 - ATUCL 3746-900 Station Details panel 4-40
 - ATUFS1 Frame Relay Switching Equipment Page 1 panel 4-128
 - ATUFT1 Frame Relay Terminating Equipment Details Page 1 panel 4-136
 - ATUFT2 Frame Relay Terminating Equipment Details Page 2 panel 4-144
 - ATUSD SDLC Station Details panel 4-241
 - PU status monitoring field 4-113, 4-141, 4-288
 - ATUCH Channel Adapter Details panel 4-33
 - ATUCL 3746-900 Station Details panel 4-40
 - ATUSD SDLC Station Details panel 4-242
 - publications X-21
 - 3745 X-23
 - 3746 X-24
 - MVS/ESA X-24
 - NetView X-22
 - NPM X-23
 - NPSI X-22
 - NRF X-23
 - NTO X-23
 - related X-23
 - SecureWay X-22
 - SNA X-22, X-24
 - TCAM X-24
 - VTAM X-22
 - PUDR (physical unit dynamic reconfiguration pool) 4-19
 - PUDRPOOL statement 4-23
- ## Q
- QSIZE keyword and field
 - monitoring 4-56, 4-123
 - tuning 6-20, 6-55
 - QSIZEDE keyword and field
 - monitoring 4-56, 4-123
 - tuning 6-20, 6-54
 - QSZALERT tuning fields 4-8, 6-7
 - QUED LMT tuning field
 - ATUML Multi-Link Transmission Group panel 4-186, 6-94
 - cross-reference table 5-6
- ## R
- RCVBF frame sizes (Token Ring) 4-281
 - Receive Errors THRESH tuning field 4-112, 6-43
 - REDIAL tuning field
 - ATUFP2 Frame Relay Details Page 2 panel 4-119, 6-50
 - ATUSP2 SDLC Peripheral Line Parameters Page 2 panel 4-256, 6-136
 - cross-reference table 5-6
 - release identifier on panels 3-7
 - REMOTTO keyword
 - ATUTL Token-Ring SNA Station panel 4-302, 6-157
 - cross-reference table 5-6
 - REPLYTO tuning field
 - ATUMT Modify Timer Value panel 4-190, 6-98
 - ATUSP2 SDLC Peripheral Line Parameters Page 2 panel 4-257, 6-139
 - cross-reference table 5-6

Index

- requirements for NTuneMON, determining 2-5
 - requirements, NTuneNCP
 - hardware 5-3
 - software 5-4
 - RESET option 2-19
 - resource vector table (RVT) 4-19, 4-23
 - RETRIES tuning field
 - ATUSD SDLC Station Details panel 4-243, 6-115
 - ATUSP2 SDLC Peripheral Line Parameters Page 2 panel 4-256, 6-138
 - cross-reference table 5-6
 - RETRYTO tuning field
 - ATUMT Modify Timer Value panel 4-190, 6-99
 - ATUSP2 SDLC Peripheral Line Parameters Page 2 panel 4-257, 6-140
 - cross-reference table 5-6
 - return codes 5-16
 - REXX 2-3, 2-5
 - RING tuning field
 - ATUFP2 Frame Relay Details Page 2 panel 4-119, 6-49
 - ATUSP1 SDLC Peripheral Line Parameters Page 1 panel 4-252, 6-128
 - cross-reference table 5-6
 - RIP-2 multicast frames 4-82, 4-85
 - RNRLIMIT tuning field
 - ATUSP2 SDLC Peripheral Line Parameters Page 2 panel 4-256, 6-136
 - cross-reference table 5-6
 - ROLL 3-5
 - route switching 4-308, 6-168
 - messages 9-11
 - RVT (resource vector table) 4-19, 4-23
- S**
- sample panel 3-6
 - SAP (service access point)
 - See DSAP tuning field, SSAP tuning field
 - saving data to NetView log 3-11
 - scanners
 - channel adapters 2-24, 4-230
 - line adapters 2-24, 4-233
 - SCE minor control block 4-19
 - SCOPE option 2-20
 - SDLC lines, adding
 - defining redefinable line 7-6
 - defining spare line 7-5
 - disabling SDLC redefinable line 7-6
 - enabling spare line 7-5
 - keywords for peripheral lines 7-6
 - line types 7-3
 - overview 7-3
 - restrictions 7-8
 - VTAM support 7-9
 - SDLC panel group 1-11
 - SDLC Peripheral Line Parameters Page 1 panel 4-249, 6-122
 - SDLC Peripheral Line Parameters Page 2 panel 4-255, 6-134
 - SDLC peripheral lines, adding 7-3
 - SDLC Physical Line Details panel 4-217, 6-102
 - SDLC Station Details panel 4-241, 6-113
 - SDLC Stations List panel 4-246
 - SDLC tuning fields 1-16
 - SecureWay publications X-22
 - selecting NCPs 2-12, 4-204
 - serial number of 3746 Model 900 frame 4-262
 - serial number of communication controller 4-28, 4-213, 4-261
 - service access point (SAP)
 - See DSAP tuning field, SSAP tuning field
 - SERVICE PRI field
 - ATUFS1 Frame Relay Switching Equipment Page 1 panel 4-128
 - tuning 6-62
 - SERVICE PRIORITY field
 - tuning 6-76
 - SERVLIM tuning field
 - ATUPL SDLC Physical Line Details panel 4-220, 6-109
 - ATUSP2 SDLC Peripheral Line Parameters Page 2 panel 4-258, 6-144
 - cross-reference table 5-6
 - SMMF (SSCP Monitor Mode Function) 4-47
 - SNA publications X-22, X-24
 - snap traces 4-269
 - SNI network names
 - ATUIB GWNAUs in Use Counts panel 4-158
 - ATUIC Non-Dynamic GWNAUs in Use Counts panel 4-161
 - ATUNA GWNAU Names and HSCBs panel 4-192
 - ATUNG HSCBs and GWNAUs panel 4-196
 - ATUNN HSCBs (Networks and HSCB Counts) panel 4-201
 - SNP (SSCP-NCP session control block) 4-24
 - softcopy documentation xxiv
 - software requirements
 - NTuneMON 2-5
 - NTuneNCP 5-4
 - source service access point (SSAP) tuning field
 - ATUTL Token-Ring SNA Station panel 4-304, 6-164
 - SPEED tuning field
 - See *also* Line Speed monitoring field
 - ATUFP Frame Relay Physical Line Details Page 1 panel 4-109, 6-35
 - ATUPL SDLC Physical Line Details panel 4-218, 6-103
 - ATUSP1 SDLC Peripheral Line Parameters Page 1 panel 4-252, 6-129

- SPEED tuning field (*continued*)
 - cross-reference table 5-6
 - SRE (subnetwork route entry pool) 4-23
 - SRETRY tuning field
 - ATUPL SDLC Physical Line Details panel 4-256, 6-136
 - cross-reference table 5-6
 - SSAP (source service access point) tuning field
 - ATUTL Token-Ring SNA Station panel 4-304, 6-164
 - SSB minor control block 4-19
 - SSCP Monitor Mode Function (SMMF) 4-47
 - SSCP-NCP session control block (SNP) 4-24
 - Station Address field 4-56
 - STATION field
 - ATUFT1 Frame Relay Terminating Equipment Details Page 1 panel 4-138, 6-71
 - ATUSD SDLC Station Details panel 4-242, 6-114
 - ATUTL Token-Ring SNA Station panel 4-303, 6-160
 - Station Name field 4-56
 - Station PRI field
 - monitoring 4-74
 - tuning 6-24
 - Station Status field 4-56
 - stations, multiplexed 4-89, 4-90
 - statistics on NCP CCU and buffer utilization 4-328
 - Status field 4-123
 - Status monitoring field
 - B-channel 4-63, 4-66
 - B-channel station 4-67
 - ESCON physical line 4-39
 - Ethernet adapter 4-84
 - frame-relay line 4-110, 4-118
 - IP interface 4-165
 - IPSP 4-102
 - ISDN logical line 4-72
 - ISDN logical station 4-74
 - ISDN physical line 4-60, 4-62
 - logical line 4-40, 4-44
 - logical station 4-344
 - MLTG line 4-187
 - physical line 4-32, 4-44, 4-96
 - PU 4-40, 4-247
 - route 4-173
 - SDLC peripheral line 4-250
 - SDLC physical line 4-219, 4-246
 - station 4-37
 - TIC 4-274, 4-298, 4-311, 4-320
 - Token-Ring physical line 4-281
 - virtual circuit 4-367
 - X.25 physical line 4-342, 4-351, 4-354, 4-358
 - SUBAREA option 2-21
 - subnet mask 4-173
 - subnetwork route entries 4-173
 - subnetwork route entry pool (SRE) 4-23
 - summaries
 - color usage in panels 3-10
 - fast-path commands 3-4
 - keywords for tuning 1-15, 5-6
 - PF keys 3-3
 - resources monitored 2-4
 - tuning 5-6
 - TYPE option values 2-21
 - Summary Status panel 4-260
 - switched line 4-109
 - switched-line information 4-119
 - switching equipment, frame-relay (FRSE)
 - definition of term X-9
 - DLCI (data link connection identifier) 4-127
 - FRSEDRPU keyword on PUDRPOOL statement 4-23
 - Synchronous Data Link Control
 - See index entries beginning with "SDLC"
- T**
- T/R Address (MAC address of destination station) tuning field
 - ATUTL Token-Ring SNA Station panel 4-305, 6-164
 - T/R LOCADD tuning field
 - ATUTP1 Token-Ring TIC Details Page 1 panel 4-311, 6-170
 - T1 TIMER
 - ATUDT ISDN Station Details panel 4-76
 - ATUFT1 Frame Relay Terminating Equipment Details Page 1 panel 4-138, 6-71
 - cross-reference table 5-6
 - T1LOC
 - ATUTL Token-Ring SNA Station panel 4-302, 6-157
 - cross-reference table 5-6
 - T1REM
 - ATUTL Token-Ring SNA Station panel 6-157
 - cross-reference table 5-6
 - T1TIMER keyword
 - ATUDT ISDN Station Details panel 4-76
 - ATUFT1 Frame Relay Terminating Equipment Details Page 1 panel 4-138, 6-71
 - ATUTL Token-Ring SNA Station panel 4-302, 6-157
 - cross-reference table 5-6
 - T2 TIMER
 - ATUDT ISDN Station Details panel 4-76
 - ATUFT1 Frame Relay Terminating Equipment Details Page 1 panel 4-138, 6-72
 - cross-reference table 5-6
 - T2LOC
 - ATUTL Token-Ring SNA Station panel 4-302, 6-158

Index

- T2LOC (*continued*)
 - cross-reference table 5-6
- T2REM
 - ATUTL Token-Ring SNA Station panel 4-302, 6-158
 - cross-reference table 5-6
- T2TIMER keyword
 - ATUDT ISDN Station Details panel 4-76
 - ATUFT1 Frame Relay Terminating Equipment Details Page 1 panel 4-138, 6-72
 - ATUTL Token-Ring SNA Station panel 4-302, 6-158
 - cross-reference table 5-6
- TCAM publications X-24
- TCP/IP (Transmission Control Protocol/Internet Protocol)
 - definition of term X-18
 - host
 - ATUID IP Interface Information Detail panel 4-166
 - ATUIX IP Router Statistics Page 2 panel 4-182
 - publications X-24
- TD Timer monitoring field 4-355
- TEXTTO tuning field
 - ATUMT Modify Timer Value panel 4-190, 6-99
 - ATUSP2 SDLC Peripheral Line Parameters Page 2 panel 4-257, 6-141
 - cross-reference table 5-6
- TG threshold
 - ATUML Multi-Link Transmission Group panel 4-186, 6-94
 - ATUSS Summary Status panel 4-265
 - ATUTG Transmission Group panel 4-295, 4-296
- TGB (transmission group control block) 4-150
- TGCONF keyword
 - ATUFT1 Frame Relay Terminating Equipment Details Page 1 panel 4-137, 4-138, 6-66, 6-71
 - ATUSD SDLC Station Details panel 4-242, 6-114
 - ATUTL Token-Ring SNA Station panel 4-303, 6-159, 6-160
- TGCONF monitoring field 4-137
- TGN option 2-21
- TGTIMER keyword 4-339
 - tuning 6-187
- thresholds
 - See also* alert thresholds
 - ATUNT NCP Network Names Table panel 4-210
 - buffers and pools 4-7, 4-24, 4-150
 - CWALL 4-5
 - ESS adapter 4-85, 4-87
 - GWNAUs 4-160, 4-162, 4-193
 - Internet router 4-178
 - local management interface (LMI), frame relay 4-114, 4-289
 - receive error, frame relay 6-43
 - resource use, example 3-9
- thresholds (*continued*)
 - slowdown 4-5
 - SNI networks and HSCBs 4-202
 - Token-Ring 4-279
 - transmission groups 4-265, 4-295
 - virtual routes 4-264, 4-336
- TIC (port) address
 - ATUTC Token-Ring Adapter List panel 4-279
 - ATUTP1 Token-Ring TIC Details Page 1 panel 4-310, 4-311
 - details 6-170, 6-178
 - option table 2-25
- TIC connection balancing 4-315, 6-174
- time stamp, beaconing 4-313
 - date stamp 4-313
- timers
 - acknowledgement (T2) 4-76, 4-138, 6-72
 - ATUMT Modify Timer Value panel 4-189, 6-97
 - channel 4-34, 4-41
 - DD 4-52
 - disable 4-364
 - enable 4-364
 - inactivity (TI) 4-52, 4-110, 4-314, 4-364, 6-38, 6-171
 - line 4-52
 - N391 4-52, 4-288
 - N392 4-52, 4-289
 - N393 4-52, 4-289
 - QLLC retry 4-345
 - reply (T1) 4-76, 4-138, 4-302
 - reply time out (REPLYTO) 4-190, 6-98, 6-139
 - retry time out (RETRYTO) 4-190, 6-99, 6-140
 - SERVLIM 4-221, 6-110
 - T20 restart 4-364
 - T21 call 4-364
 - T22 reset 4-364
 - T23 clear 4-364
 - T25 4-364
 - T26 interrupt 4-364
 - T391 4-52, 4-114, 4-289
 - T392 4-52, 4-114
 - TD 4-355
 - text time out (TEXTTO) 4-190, 6-99, 6-141
 - Token-Ring local (T2LOC) 4-302, 6-158
 - Token-Ring remote (T2REM) 4-302, 6-158
 - Token-Ring reply (T1) 4-286, 6-157
 - TP 4-354
 - transmit delay (XMITDLY) 4-190, 6-99, 6-141
- TITIMER tuning field
 - ATUFP Frame Relay Physical Line Details Page 1 panel 4-110, 6-38
 - ATUTP1 Token-Ring TIC Details Page 1 panel 4-314, 6-171
 - cross-reference table 5-6
- Token Ring
 - adapter status 4-313

- Token Ring (*continued*)
 - adapter types 2-22
 - ADDR option 4-281
 - bridges 4-301, 6-156
 - definition of term X-18
 - frame sizes 4-280
 - line status
 - ATUTA Token-Ring SNA Station List panel 4-274
 - ATUTD NTRI Frame Handlers Logical Line Details panel 4-286
 - ATUTL Token-Ring SNA Station panel 4-302
 - lines, specifying to view
 - ATUTC Token-Ring Adapter List panel 4-282
 - option table 2-22, 2-25
 - lines, viewing all 4-278
 - stations
 - ATUTA Token-Ring SNA Station List panel 4-273
 - ATUTC Token-Ring Adapter List panel 4-282
 - ATUTL Token-Ring SNA Station panel 4-301
 - details 6-156
 - option table 1-17
 - TICs (ports)
 - ATUTA Token-Ring SNA Station List panel 4-275
 - ATUTC Token-Ring Adapter List panel 4-279
 - ATUTD NTRI Frame Handlers Logical Line Details panel 4-286
 - ATUTF NTRI Frame Handler Logical Lines panel 4-291
 - ATUTI Token-Ring IP Statistics panel 4-298
 - ATUTL Token-Ring SNA Station panel 4-304
 - ATUTP1 Token-Ring TIC Details Page 1 panel 4-310
 - ATUTP2 Token-Ring TIC Details Page 2 panel 4-319
 - details 6-170, 6-178
 - option table 2-25
 - traffic rates 4-301, 6-156
 - TYPE option 2-22
- Token-Ring IP Statistics panel 4-298
- Token-Ring logical link block (TR LLB) 4-21
- Token-Ring panel group 1-12
- Token-Ring SNA Station List panel 4-273, 4-278
- Token-Ring SNA Station panel 4-301, 6-156
- Token-Ring TIC Details Page 1 panel 4-310, 6-170
- Token-Ring TIC Details Page 2 panel 4-319, 6-178
- TOTAL tuning field
 - ATUML Multi-Link Transmission Group panel 4-186, 6-94
 - ATUTG Transmission Group panel 4-296
 - summary status 4-265
- TP Timer monitoring field 4-354
- TR LLB (Token-Ring logical link block) 4-21
- traces 4-269
- trademarks xvii
- traffic rates
 - Ethernet-type LAN 4-82, 4-85
 - Internet router 4-175
 - Token-Ring 4-301, 6-156
 - virtual routes 4-335
- TRANSBUF keyword and field 4-110
- tuning 6-38
- TRANSFR tuning field
 - ATUSP1 SDLC Peripheral Line Parameters Page 1 panel 4-253, 6-131
 - cross-reference table 5-6
- transit routing table entries pool (TRT) 4-150
- Transmission Control Protocol/Internet Protocol (TCP/IP)
 - definition of term X-18
 - host
 - ATUID IP Interface Information Detail panel 4-166
 - ATUIX IP Router Statistics Page 2 panel 4-182
 - publications X-24
- transmission group
 - ATUML Multi-Link Transmission Group panel 4-184
 - ATUML Multi-Link Transmission Group panel, tuning 6-93
 - definition of term X-18
 - options
 - MLTG 2-23
 - TG 2-24
- transmission group control block (TGB) 4-150
- Transmission Group panel 4-294
- transmission group timer 4-339
- tuning 6-187
- troubleshooting 2-16, 2-25
- TRT (transit routing table entries pool) 4-150
- TSLOW CNT
 - ATUBP NCP Buffer Pool panel 4-8, 6-6
- TSLOW%
 - ATUBP NCP Buffer Pool panel 4-8, 6-6
- TSS lines 6-38
- tuning error 5-16
- tuning fields
 - #PIUs/BLOCK
 - ATUFT1 Frame Relay Terminating Equipment Details Page 1 panel 6-73
 - ATUSD SDLC Station Details panel 6-114
 - ATUTL Token-Ring SNA Station panel 6-160
 - ACTIVTO 6-135
 - ALERT CNT 6-6
 - ALERT THRS 6-6
 - ALERT% 6-6
 - ANSTONE 4-119, 6-124
 - ARP Address Format
 - ATUID IP Interface Information Detail panel 6-91
 - ATUDT ISDN Station Details panel 6-24

Index

tuning fields (*continued*)

Bal Factor 4-100, 6-29
BLOCK Gen
 ATUFT1 Frame Relay Terminating Equipment
 Details Page 1 panel 6-75
 ATUSD SDLC Station Details panel 6-119
 ATUTL Token-Ring SNA Station panel 6-167
CCLID 6-125
CLOCKNG 6-125
COMRATE
 ATUFS1 Frame Relay Switching Equipment Page
 1 panel 6-61
 ATUFT1 Frame Relay Terminating Equipment
 Details Page 1 panel 6-65, 6-78
 ATUTF NTRI Frame Handler Logical Lines
 panel 6-152
 ATUTP2 Token-Ring TIC Details Page 2
 panel 6-178
CONGESTION
 ATUFT1 Frame Relay Terminating Equipment
 Details Page 1 panel 6-66
 ATUSD SDLC Station Details panel 6-114
 ATUTL Token-Ring SNA Station panel 6-159
Conn Bal Fact 4-315, 6-174
cross-reference table 5-6
DATRATE 6-126
destination service access point (DSAP) 6-165
DSAP (destination service access point) 6-165
DUPLEX 6-126
DYNPOOL TOTAL 6-5
DYNWIND()
 ATUFP Frame Relay Physical Line Details Page 1
 panel 6-41, 6-42
 ATUFT1 Frame Relay Terminating Equipment
 Details Page 1 panel 6-67—6-71, 6-73
 ATUTL Token-Ring SNA Station panel 6-160
 ATUTP1 Token-Ring TIC Details Page 1
 panel 6-171
ETRATIO 6-135
HDXSP 6-144
HIGH 6-94
HISPEED
 ATUPL SDLC Physical Line Details panel 6-105
 ATUSP1 SDLC Peripheral Line Parameters Page
 1 panel 6-127
HPRSATT (HPRATT keyword) 6-85
HPRMLC (HPRMLC keyword) 6-86
HPRSMPS (HPRMPS keyword) 6-84
IP DATAGRAM SNAP TRACE ENABLED 6-149
IP ROUTE SNAP TRACE ENABLED 6-150
IPPOOL TOTAL 6-4
LMI
 ATUFP Frame Relay Physical Line Details Page 1
 panel 6-44
 ATUTF NTRI Frame Handler Logical Lines
 panel 6-153

tuning fields (*continued*)

LOW 6-94
LSPRI
 ATUFP Frame Relay Physical Line Details Page 1
 panel 6-106
 ATUPL SDLC Physical Line Details panel 6-143
MAC address 4-287, 6-153
MAXDATA
 ATUFT1 Frame Relay Terminating Equipment
 Details Page 1 panel 6-74
 ATUSD SDLC Station Details panel 6-118
 ATUTL Token-Ring SNA Station panel 6-165
MAXOUT
 ATUFT1 Frame Relay Terminating Equipment
 Details Page 1 panel 6-74
 ATUSD SDLC Station Details panel 6-118
 ATUTL Token-Ring SNA Station panel 6-166
MEDIUM 6-94
MODULO 6-119
N3GEN
 ATUFT1 Frame Relay Terminating Equipment
 Details Page 1 panel 6-72
 ATUTL Token-Ring SNA Station panel 6-159
NCP USE 6-123
NEWSYNC 6-127
NRZI
 ATUFP Frame Relay Physical Line Details Page 1
 panel 6-37
 ATUPL SDLC Physical Line Details panel 6-109
 ATUSP1 SDLC Peripheral Line Parameters Page
 1 panel 6-128
NTRI/FRAME RELAY SNAP TRACE
 ENABLED 6-148
NTUNECOL
 ATUST NCP Function Activation panel 6-150
ODLC SNAP TRACE ENABLED 6-148
OUTBOUND QUEUE SIZE Maximum 4-103, 6-32
PASSLIM 6-116
PAUSE
 ATUPL SDLC Physical Line Details panel 6-107
 ATUSP2 SDLC Peripheral Line Parameters Page
 2 panel 6-142
PIUs/BLOCK
 See tuning fields, #PIUs/BLOCK
PRI 6-95
Priority 4-118, 6-48
QSZALERT 4-8, 6-7
QUED LMT 6-94
receive error threshold for frame relay 6-43
REDIAL 4-119, 6-136
REPLYTO
 ATUMT Modify Timer Value panel 6-98
 ATUSP2 SDLC Peripheral Line Parameters Page
 2 panel 6-139
RETRIES
 ATUSD SDLC Station Details panel 6-115
 ATUSP2 SDLC Peripheral Line Parameters Page
 2 panel 6-138

tuning fields *(continued)*

RETRYTO
 ATUMT Modify Timer Value panel 6-99
 ATUSP2 SDLC Peripheral Line Parameters Page 2 panel 6-140
 RING 4-119, 6-128
 RNRLIMIT 6-136
 SAP (service access point)
 See SSAP (source service access point)
 See tuning fields, DSAP (destination service access point)
 service access point (SAP)
 See SSAP (source service access point)
 See tuning fields, DSAP (destination service access point)
 SERVLIM
 ATUPL SDLC Physical Line Details panel 6-109
 ATUSP2 SDLC Peripheral Line Parameters Page 2 panel 6-144
 source service access point (SSAP) 6-164
 SPEED
 ATUFP Frame Relay Physical Line Details Page 1 panel 6-35
 ATUPL SDLC Physical Line Details panel 6-103
 ATUSP1 SDLC Peripheral Line Parameters Page 1 panel 6-129
 SRETRY 6-136
 SSAP (source service access point) 6-164
 STATION
 ATUFT1 Frame Relay Terminating Equipment Details Page 1 panel 6-71
 ATUSD SDLC Station Details panel 6-114
 ATUTL Token-Ring SNA Station panel 6-160
 T/R Address 6-164
 T/R LOCADD 6-170
 T1 TIMER 6-71
 T1LOC 6-157
 T1REM 6-157
 T2 TIMER 6-72
 T2LOC 6-158
 T2REM 6-158
 TEXTTO
 ATUMT Modify Timer Value panel 6-99
 ATUSP2 SDLC Peripheral Line Parameters Page 2 panel 6-141
 thresholds 6-94
 TITIMER
 ATUFP Frame Relay Physical Line Details Page 1 panel 6-38
 ATUTP1 Token-Ring TIC Details Page 1 panel 6-171
 TOTAL 6-94
 TRANSFR 6-131
 TSLOW CNT 6-6
 TSLOW% 6-6
 VR MAX, VR MIN 6-182

tuning fields *(continued)*

VTAM USE 6-123
 X21NTWK 6-132
 XMITDLY
 ATUMT Modify Timer Value panel 6-99
 ATUSP2 SDLC Peripheral Line Parameters Page 2 panel 6-141
 tuning fields, summary 5-6
 tuning panels
 ATUBP NCP Buffer Pool panel 6-4
 ATUCH Channel Adapter Details panel 6-10
 ATUCL 3746-900 Station Details panel 6-12
 ATUDK ISDN Physical Line Details panel 6-15
 ATUDK2 ISDN Physical Line Details Page 2 panel 6-19
 ATUFB Frame Relay DLCI CIR Parameters panel 6-26
 ATUFD Frame Relay DLCI to Balance Table panel 6-29
 ATUFI Frame-Relay IP Link Statistics panel 6-32
 ATUFP Frame Relay Physical Line Details Page 1 panel 6-34
 ATUFP2 Frame Relay Details Page 2 panel 6-48
 ATUFP3 Frame Relay Details Page 3 panel 6-53
 ATUFS1 Frame Relay Switching Equipment Page 1 panel 6-61
 ATUFT1 Frame Relay Terminating Equipment Details Page 1 panel 6-64
 ATUFT2 Frame Relay Terminating Equipment Details Page 2 panel 6-78
 ATUGP Network CB Pools/Tables panel 6-81
 ATUHP HPR & Other Global Flow Control Params panel 6-84
 ATUID IP Interface Information Detail panel 6-90
 ATUML Multi-Link Transmission Group panel 6-93
 ATUMT Modify Timer Value panel 6-97
 ATUPL SDLC Physical Line Details panel 6-102
 ATUSD SDLC Station Details panel 6-113
 ATUSP1 SDLC Peripheral Line Parameters Page 1 panel 6-122
 ATUSP2 SDLC Peripheral Line Parameters Page 2 panel 6-134
 ATUST NCP Function Activation panel 6-147
 ATUTD NTRI Frame Handlers Logical Line Details panel 6-152
 ATUTL Token-Ring SNA Station panel 6-156
 ATUTP1 Token-Ring TIC Details Page 1 panel 6-170
 ATUTP2 Token-Ring TIC Details Page 2 panel 6-178
 ATUVA Virtual Route Control Block Details panel 6-182
 ATUVT VR Alert Timer panel 6-185
 ATUXP X.25 MCH Physical Line Details Page 1 panel 6-189

Index

turquoise highlighting 4-161, 5-15

Type monitoring field

channel adapter 4-32, 4-231

communication adapter 4-238

connection 4-165

DLCI 4-89

ESCP adapter 4-39, 4-43

line 4-186

line adapter 4-95, 4-234

physical line 4-96

PU 4-44, 4-247

station 4-281

X.25 resource 4-351

TYPE option 2-21

typing values in panel fields 3-7

U

underlined input field 3-8

UNIQUE monitoring field 4-305, 6-164

usage tier 4-28, 4-234

USE keyword (NCP USE and VTAM USE tuning fields)

ATUSP1 SDLC Peripheral Line Parameters Page 1

panel 4-250, 6-123

cross-reference table 5-6

utilization

CCU and buffers, histogram 4-328

resource comparison 2-24, 4-212

V

V25BIS monitoring field 4-120

variables, global

buffers and pools 4-7, 4-24, 4-150

Ethernet-type LAN 4-82, 4-85

GLOBAL option 2-18

RESET option 2-19

Token-Ring 4-279

transmission groups 4-265

virtual routes 4-264

vector table, resource (RVT) 4-19, 4-23

Virtual Route Alert Timer panel 4-338

Virtual Route Control Block Details panel 4-331, 6-182

Virtual Route panel 4-334

virtual route status

See VR status

virtual routes

alert information 4-339, 6-185

ATUVA Virtual Route Control Block Details

panel 4-331

ATUVR Virtual Route panel 4-334

definition of term X-19

introduction 2-25

virtual routes panel group 1-13

VM, installing NTuneMON on 2-9

VM/ESA 5-4

VR Alert Timer panel

tuning 6-185

VR HOP 4-331

VR ID 4-331

VR status 4-336

VR window size (MAX,MIN)

ATUVA Virtual Route Control Block Details

panel 4-332, 6-182

ATUVR Virtual Route panel 4-335

cross-reference table 5-6

VRB control block 4-12

VRPWSnm keyword (VR MAX/MIN tuning fields)

ATUVA Virtual Route Control Block Details

panel 4-332, 6-182

ATUVR Virtual Route panel 4-335

cross-reference table 5-6

VRTIMERn keyword 4-339

tuning 6-185

VTAM PATH statement

use with VRPWS keyword 6-182, 6-183

VTAM publications X-22

VTAM USE tuning field (USE keyword)

ATUSP1 SDLC Peripheral Line Parameters Page 1

panel 4-250, 6-123

cross-reference table 5-6

VTAM, relationship to NTuneMON 2-3, 2-25

VTAM, sample definition statement X-8

VTAM, support for spare lines 7-9

VVT (virtual route vector table) 4-21

VxRx release identifier 3-7

W

warnings

2845 and 2848 control units 6-141

global variables, saving 2-18

NTuneNCP access via NTuneMON 5-6

programming interface, not a xvi

reloading while tuning 5-6

scanner error, false 6-140

timer restrictions 6-97, 6-100

white highlighting 5-15

window size, dynamic

See DYNWIND() tuning fields

window sizes, virtual routes 4-335

X

X.21 Switched monitoring field 4-253, 4-355

X.25 MCH Physical Line Details Page 1 panel 4-353

X.25 MCH Physical Line Details Page 2 panel 4-362

X.25 MCH Physical Line Details Panel

tuning 6-189

X.25 MCH Physical Line List panel 4-350

- X.25 MCH Physical Line Statistics panel 4-348
- X.25 panel group 1-14
- X.25 support 1-14
- X.25 VCCPT Information panel 4-369
- X.25 Virtual Circuit Details panel 4-341
- X.25 Virtual Circuit List panel 4-366
- X21NTWK tuning field
 - ATUSP1 SDLC Peripheral Line Parameters Page 1 panel 4-253, 6-132
 - cross-reference table 5-6
- X21SW keyword 4-355
- X21SW monitoring field 4-253
- X25SNAP keyword 4-270, 6-149
- XMITDLY tuning field
 - ATUMT Modify Timer Value panel 4-190, 6-99
 - ATUSP2 SDLC Peripheral Line Parameters Page 2 panel 4-257, 6-141
 - cross-reference table 5-6
- XRF logical unit block extension (LUX) 4-21

Y

- year-2000 color coding 4-28
- yellow highlighting 3-10, 4-161

Tell Us What You Think!

**NTuneMON
User's Guide**

Publication No. SC31-6266-06

We hope you find this publication useful, readable, and technically accurate, but only you can tell us! Your comments and suggestions will help us improve our technical publications. Please take a few minutes to let us know what you think by completing this form. If you are in the USA, you can mail this form postage free or fax it to us at 1-800-253-3520. Elsewhere, your local IBM branch office or representative will forward your comments or you may mail them directly to us.

Overall, how satisfied are you with the information in this book?	Satisfied	Dissatisfied
	<input type="checkbox"/>	<input type="checkbox"/>

How satisfied are you that the information in this book is:	Satisfied	Dissatisfied
Accurate	<input type="checkbox"/>	<input type="checkbox"/>
Complete	<input type="checkbox"/>	<input type="checkbox"/>
Easy to find	<input type="checkbox"/>	<input type="checkbox"/>
Easy to understand	<input type="checkbox"/>	<input type="checkbox"/>
Well organized	<input type="checkbox"/>	<input type="checkbox"/>
Applicable to your task	<input type="checkbox"/>	<input type="checkbox"/>

Specific comments or problems:

Please tell us how we can improve this book:

Thank you for your comments. If you would like a reply, provide the necessary information below.

Name

Address

Company or Organization

Phone No.



Fold and Tape

Please do not staple

Fold and Tape

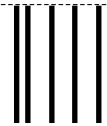

NO POSTAGE
NECESSARY
IF MAILED IN THE
UNITED STATES

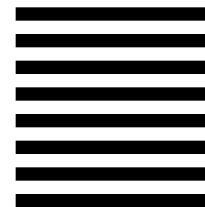

BUSINESS REPLY MAIL

FIRST-CLASS MAIL PERMIT NO. 40 ARMONK, NEW YORK

POSTAGE WILL BE PAID BY ADDRESSEE

Design & Information Development
Dept. CGF/Bldg. 656
International Business Machines Corporation
PO BOX 12195
RESEARCH TRIANGLE PARK NC 27709-9990



Fold and Tape

Please do not staple

Fold and Tape



File Number: S370/4300/30XX-50
Program Number: 5648-141



Printed in the United States of America
on recycled paper containing 10%
recovered post-consumer fiber.

SC31-6266-06

